

SEACAP 21/04

**Theme 2**  
**Factors Influencing Slope  
Stability in Laos**

# Theme 2

## Factors Influencing Slope Stability in Laos

- 2.1 Topography and Geology
- 2.2 Climate and Rainfall
- 2.3 River and Stream Erosion
- 2.4 Engineering Effects

## SEACAP 21/04

**2.1 Topography and Geology**

- **Topography (slope angle / steepness)**
- **Geology (Rock type and structure)**
- **Weathering**
- **Vegetation and Land Use**
- **Rainfall & Groundwater (covered in Theme 2.2)**

SEACAP 21/04

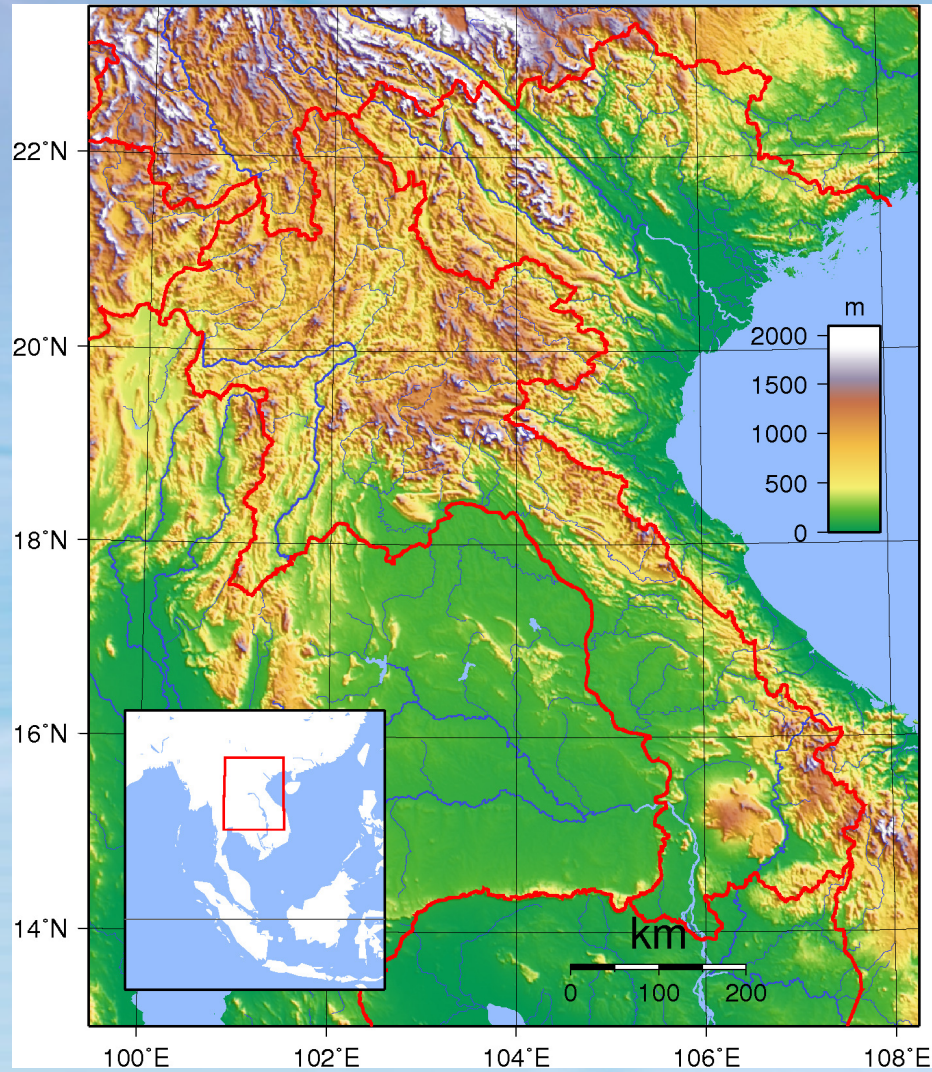

# Laos Topography

## SEACAP 21/04

## Relationship between slope angle and landsliding / slope stability

Studies in Hong Kong have shown that slopes of 30-40 degrees are more susceptible to landsliding because:

- Steep slopes are subjected to more erosion which continually removes the soil (produced from weathering of the underlying bedrock) as it forms.
- On shallower slopes however (typically 30-40 degrees) thick deposits of soil can accumulate as the rate of soil production is greater than the rate of erosion.
- On slopes of less than 30 degrees landsliding is less common as the shear stresses are lower.

# SEACAP 21/04

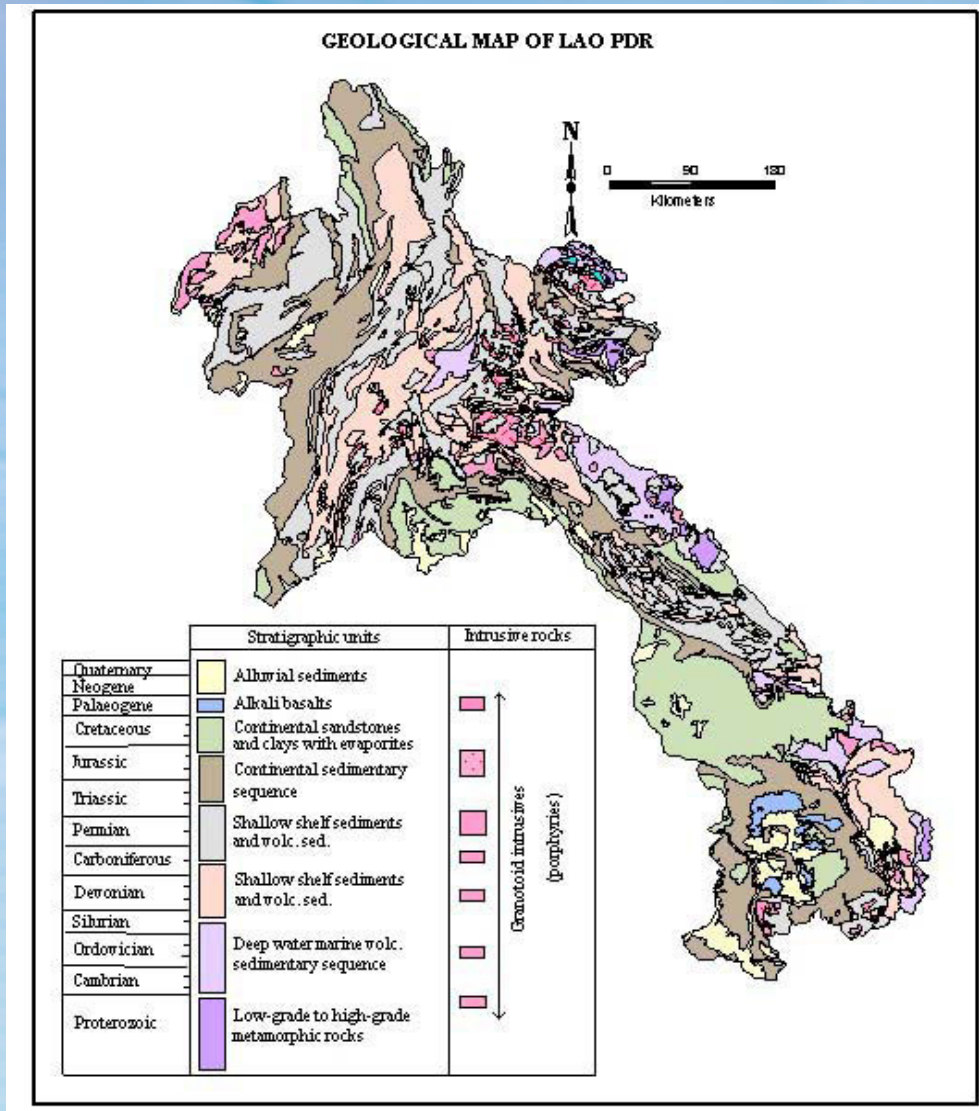

# Laos Geology

SEACAP 21/04

Geology (rock type & structure)

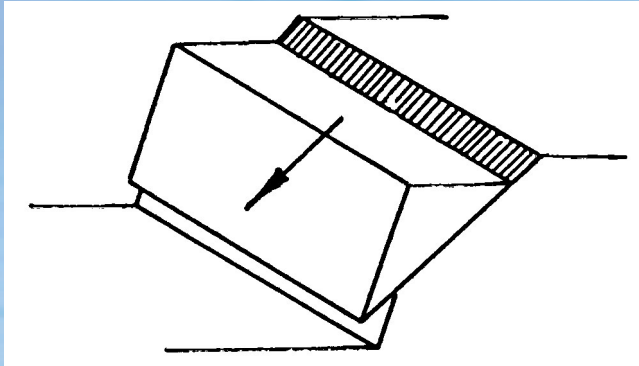

Planar Failure

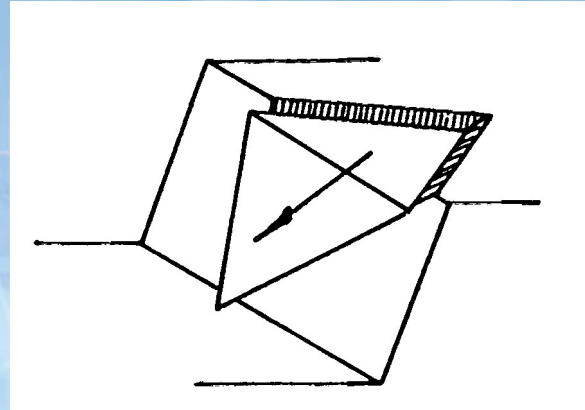

Wedge Failure

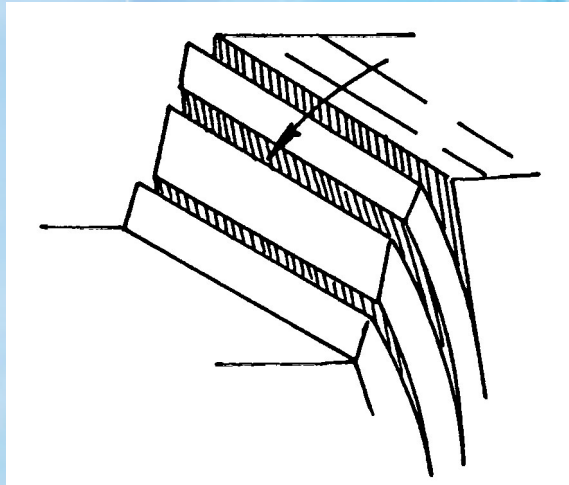

Toppling Failure

## SEACAP 21/04

### Geology (rock type and structure)

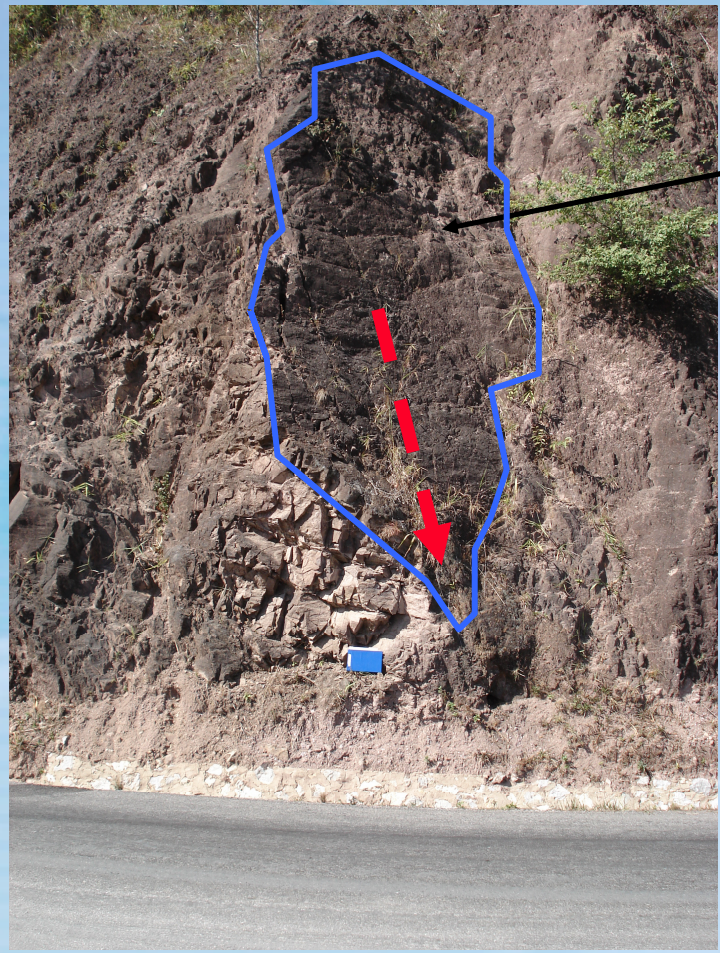

Discontinuity Surface in rock cut slope on Road 13N

SEACAP 21/04

Geology (rock type & structure)

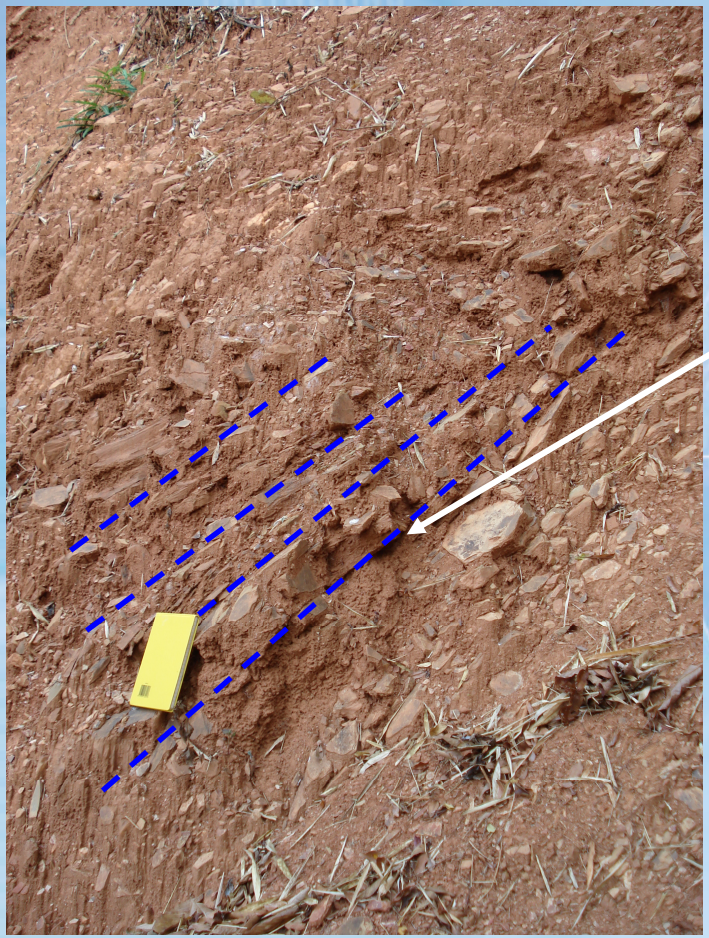

Relict (old)  
discontinuities in  
weathered rock/soil

SEACAP 21/04

## Weathering

Weathering can be defined as....

*“mechanical and chemical processes which cause the breakdown of rocks”*

Two main types of weathering are:

- *Disintegration – physical or mechanical weathering involving the breakdown of rocks into smaller fragments*
- *Decomposition – chemical weathering involving a change in the chemical composition of the rocks*

## SEACAP 21/04

# Climate & Weathering – Distribution of Tropical Residual Soils

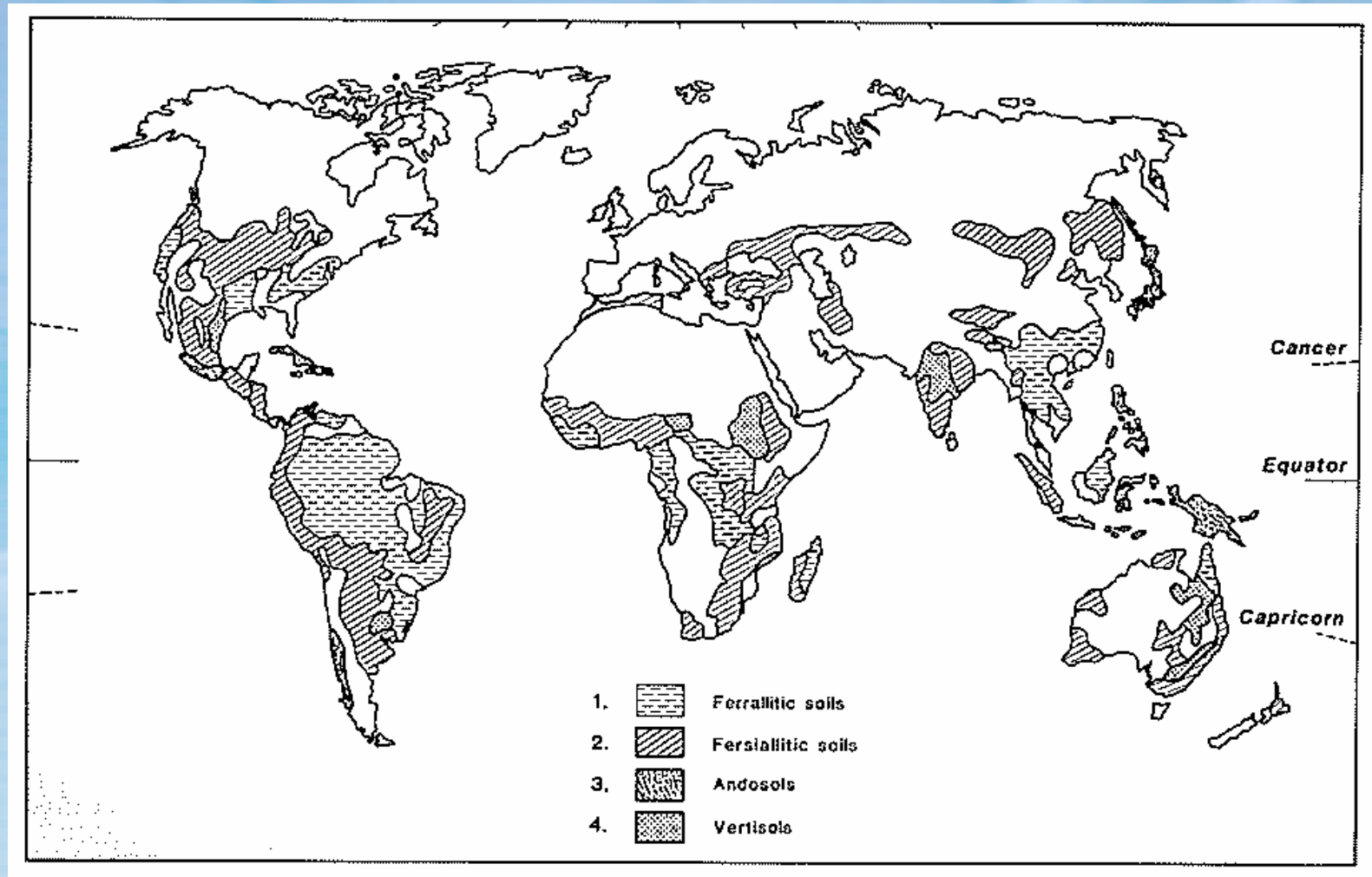

## SEACAP 21/04

### Examples of Tropical Residual Soil From Earlier SEACAP Sites



SEACAP 21/04

'Typical' Weathering Profile

Tropical  
Residual  
Soil

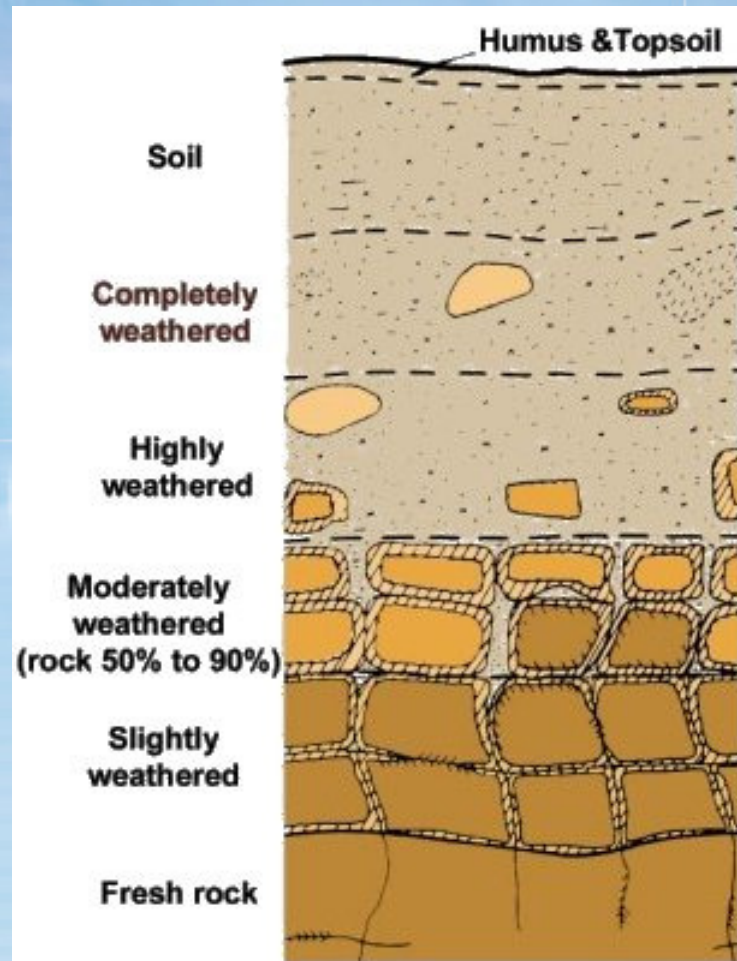

Residual Soil (VI)

Saprolite

## SEACAP 21/04

### Scale of Weathering Grades of Rock Mass

Term	Description	Grade
Fresh	No visible sign of rock material weathering; perhaps a slight discolouration on major discontinuity surfaces.	I
Slightly Weathered	Discolouration indicates weathering of rock material and discontinuity surfaces. All of the rock materials may be discoloured by weathering.	II
Moderately Weathered	Less than half the rock material is decomposed or disintegrated to a soil. Fresh or discoloured rock is present either as a continuous framework or as corestones.	III
Highly Weathered	More than half of the rock material is decomposed or disintegrated to a soil. Fresh or discoloured rock is present either as a discontinuous framework or as corestones.	IV
Completely Weathered	All rock material is decomposed and or disintegrated to soil. The original mass structure is still largely intact.	V
Residual Soil	All rock material is converted to soil. The mass structure and material fabric are destroyed. There is a large change in volume, but the soil has not been significantly transported.	VI

SEACAP 21/04

## The Effects of Weathering

- Overall reduction in the density of the material
- Corresponding increase in pore space and permeability
- Reduction in material strength and coherance

SEACAP 21/04

## Vegetation and Land Use

### Effects of Vegetation on Slope Stability:

1. **Roots provide mechanical reinforcement of the soil profile by growing downwards through potential shear surfaces.**
2. **Plants can lower the water table by drawing up water in their roots (transpiration) and thus lower the water table or prevent soil saturation from occurring.**