

SEACAP 21/002

**Feasibility Study for a
National Programme
to Manage Slope Stability**

**SEACAP Practitioners' Workshop
4-5 November 2008**

**Principal Land
use –50%**



Topography, 70% hilly/mountainous, highest point 2820m asl



Weather



Location	AARfall	Range
Vang Vieng	3900mm	3150-4550mm
Luang Prabang	1430mm	1150-1800mm



Rocks & Soils

Geomorphology













Scope of the Feasibility Study

- **Assess the magnitude of the slope stability issue, and its economic and social impact**
- **Assess the technical, economic and financial feasibility of a slope management programme**
- **Review the capacity of the MPWT to provide quality engineering services for landslide prevention and management, and the promotion of hill slope stabilisation**
- **Define a costed programme with expected outputs and proposed implementation arrangements**

Principal Activities Undertaken

- **Collection of landslide incidence and repairs data from MPWT and others**
- **Review of topographic, geological and rainfall effects on roadside slope stability**
- **Collection of a Landslide Inventory on selected roads**
- **Economic evaluation of landslide impacts and justification of pro-active and reactive stabilisation/protection measures**
- **Review of MPWT capacity for slope stability management**
- **Recommendations for MPWT capacity strengthening & a slope stability management programme**
- **Preparation of Typical Details for slope stabilisation and bio-engineering works**

Landslide Inventory

- Notes, photographs and hazard/risk rating for >150 landslides
- Over 1,500 km of the 7000 km National Road included in Inventory
- Approx 50% of the hilly or mountainous National Road network

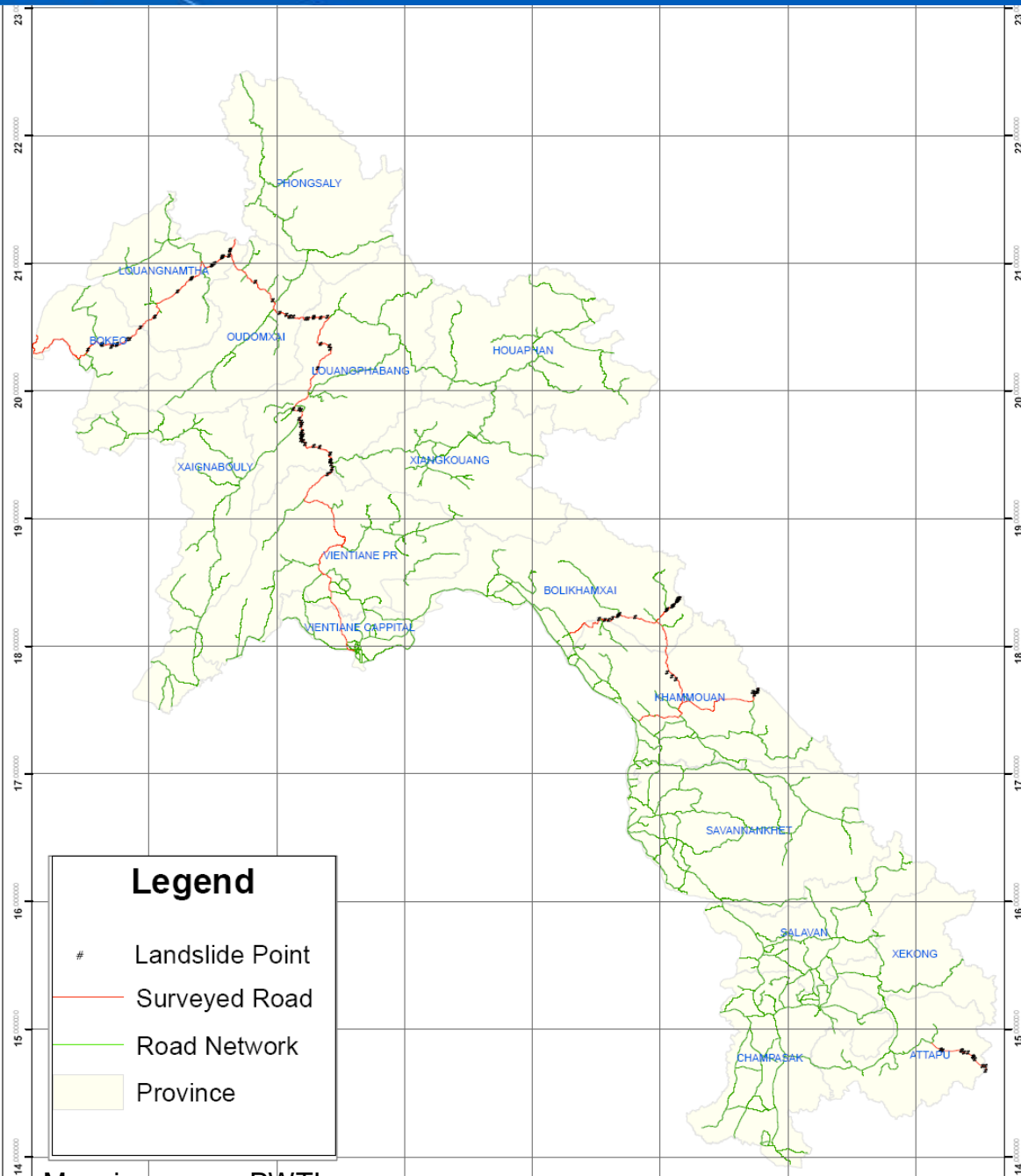

Legend

- # Landslide Point
- Surveyed Road
- Road Network
- Province

Mapping source PWTI

Risk Ranking for Prioritisation of Landslide Interventions

Actual (current condition) or expected consequences (without mitigation)	Ranking				
	1	2	3	4	5
Road completely lost (including road subsidence greater than 1m)	✓				
Road partially lost		✓			
Road completely blocked		✓			
Road subsidence less than 1m		✓			
Road partially blocked			✓		
Productive agricultural or forest land lost or destroyed			✓		
Walls damaged or slope drainage blocked or damaged				✓	
Roadside drainage damaged or blocked					✓
Continued erosion without destroying vegetation cover					✓

Ranking

1. Top priority, emergency measures required immediately; buildings may need to be evacuated.
2. High priority; realignment may be necessary.
3. Moderate priority, but some temporary remedial measures are required immediately, such as slip debris clearance, emergency road signing etc.
4. Low priority, but some temporary remedial measures are required quickly, such as slip debris clearance.
5. Least priority, but should be tackled as soon as possible under routine maintenance.

Summary of Findings

- **Over 70% of recorded landslides had taken place above the road**
- **Approximately 60% of total recorded landslides were assigned low risk categories**
- **4% of recorded landslides were judged to be rock slope failures, i.e. the vast majority were in soil or weathered rock**
- **3% of recorded landslides were judged to have resulted in movement of the entire carriageway width, i.e. entire hillside**

What constitutes a landslide management programme?

- Investment in landslide avoidance/mitigation during initial alignment and road **DESIGN**
- **CONSTRUCTION** practices sympathetic to slope stability (cut, fill, spoil disposal, drainage control etc)
- Pro-active and reactive measures during **OPERATION**

How do we assess the Feasibility of this Management Programme?

- Confirm the practicable and technical feasibility of implementing slope management measures
- Compare costs of slope management with benefits, i.e. reduced engineering, social & environmental costs caused by landslides.
 - Slope management costs:
 - Improved alignments
 - More stable cut and fill slopes
 - Enhanced slope drainage works, etc
 - Landslide costs:
 - Repairs/losses caused by landslide impacts to engineering assets
 - Landslide debris clearance and access provision in landslide areas
 - Traffic delays
 - Social and environmental costs

Summary of emergency maintenance expenditure over recent years (US\$ millions)

Fiscal Year	Landslide removal and repair	Carriageway repairs and road grading	Total emergency maintenance expenditure
2004-05	5.15	1.19	6.34
2005-06	3.17	3.43	6.59
2006-07	3.14	2.08	5.21

Estimated economic losses incurred by landslide road blockages according to period of blockage and AADT

Blockage Period	Economic Losses (US\$)					
	AADT 100			AADT 300		
	VOT	VOC	Total	VOT	VOC	Total
3 hrs	93	686	779	280	2,057	2,337
6 hrs	373	2,742	3,115	1,119	8,227	9,346
12 hrs	1,491	10,969	12,460	4,474	32,907	37,381
24 hrs	5,966	43,876	49,842	17,897	131,627	149,524

Social and Environmental Costs

- **There have been no known deaths caused by landslides within the Laos road network RoW**
- **Other social costs, such as disrupted access to schools and health care etc, while important locally and for short periods of time, are not as significant as they might be due to low population density**
- **Environmental costs, including loss of forest resources, loss of farmland and sediment impacts downstream, are also considered to be low to moderate (<US\$10,000 per average slide)**

Economic Feasibility Assessment

The Net Present Value was used to determine the economic return on investment in:

- Enhanced slope management during DESIGN & CONSTRUCTION
- Proactive/reactive interventions during OPERATION

Due to limited existing landslide data, several assumptions had to be made in terms of engineering intervention costs, landslide frequency and anticipated reduction rates in landslide costs. The costs of repairing damage caused by the various landslide types were derived from SEACAP 21/001 information from Roads 13N & 7

Conclusion of the Economic Analysis

- On the basis of the data available & the assumptions made, the economic return on investment in slope management proved marginal
- However, in areas of the most significant landsliding it is anticipated that this investment will ultimately prove to be economically beneficial
- The analysis was very sensitive to the discount rate used, traffic volumes and the timing of landslide events in relation to the timing of the investments
- Given the anticipated increase in traffic flows over the forthcoming years, the justification in investments in slope management is likely to increase significantly
- There is likely to be a growing public expectation for road access provision with minimum delays and hold-ups
- There is also strategic (nationally and internationally) importance for road access provision

Review of MPWT Capacity to Manage Landslides

- The MPWT and road sector is already in the process of change
- The revised structure could accommodate a stronger slope stabilisation programme
- The current procedures for emergency slope management appear adequate, though pro-active measures should be strengthened
- There is a shortage of technical skills in slope assessment, & the design & construction of slope stabilisation measures
- Skills development needs to be at several levels (management, design, supervision & technical)
- It needs to be both Central & Provincial
- There needs to be adequate coverage of personnel to allow for staff movement (which is increasing in the new organisation)
- There needs to be a way of sustaining the training in the long term (e.g. through strengthening University involvement)
- There is a significant knowledge gap on landslide occurrence & impact

Components of the Slope Stability Management Programme

- **Goals:**
 - **Enhanced Geo-Engineering for New Road Construction and Improvement Projects**
 - **Targeted and Affordable Slope Stability Interventions (Pro-active and Reactive Measures During Operation)**
- **Components for Achieving Goals**
 - **Capacity Development**
 - **Risk Assessment and Prioritisation of Interventions**
 - **Selected Rehabilitation Projects to Take the Process Forward**

Proposed Specific Actions for MPWT

- **Confirm service standards (acceptable risk) for landslide management**
- **Review engineering procedures for landslide management in the light of SEACAP 21 outputs, and disseminate accordingly**
- **Review geometric standards of all classes of roads with a view to reducing slope instability wherever possible**
- **Add the proposed staff training to the current Organisational Capacity Development Plan**
- **Commission specialists to prepare & implement the slope management training required in landslide recognition, assessment & management**
- **Develop & apply the risk assessment & prioritisation system instigated under SEACAP 21/02. Confirm pilot locations for enhanced slope management & implement works as part of the training programme**
- **Implement landslide record, impact & monitoring programme, as part of the above.**

Possible Short List of Potential Rehabilitation Projects for Consideration Based on Risk Ranking

Site location	Failure category	Risk ranking (from SW landslide inventory)	Estimated Cost (US\$)*	Priority against MPWT strategy**	Final list?
NR 13N, 262+900	Above road	24	60,000	High	✓
NR 12, 136+900	Above road	18	50,000	High	✓
NR 12, 138+400	Above road	18	100,000	High	✓
NR 12, 141+500	Above road	18	100,000	High	✓
Patmong-Luang Prabang, 68+100 from Patmong	Below road	54	100,000	Moderate	✓
NR 13N, 239+400	Below road	36	75,000	Moderate	✓
NR 13N, 329+100	Below road	36	100,000	Moderate	✓

* Estimates only provisional: will require confirmation during early stages of proposed Programme

** According to the likelihood of a failure causing a total blockage or loss of the road for at least three hours (in the case of National Roads).

Further Information



South-East Asia Community Access Programme



ສາມາດ ເຊື່ອມຕໍ່ກັນ ທີ່ເມັດ
LAO CONSULTING GROUP



ສາມາດ & ສາມາດ ເຊື່ອມຕໍ່ກັນ ທີ່
SD & XP Consultants Group

SEACAP 21/002: Feasibility Study for a National Programme to Manage Slope Stability

Contract No SEACAP 21/002

Final Report: Main Report
September 2008



South-East Asia Community Access Programme



ສາມາດ ເຊື່ອມຕໍ່ກັນ ທີ່ເມັດ
LAO CONSULTING GROUP



ສາມາດ & ສາມາດ ເຊື່ອມຕໍ່ກັນ ທີ່
SD & XP Consultants Group

SEACAP 21/002: Feasibility Study for a National Programme to Manage Slope Stability

Contract No SEACAP 21/002

Final Report: Background Paper
12 September 2008

‘Landslide impacts on the road network of Lao PDR and the feasibility of implementing a slope management programme’

Gareth Hearn, Tim Hunt, John Howell. Nov 2008, International Landslide Forum, Sendai, Japan

Assistance and support by Chanh Bouphalivanh, Sysouvanthong Sengmany, Xayphone Chonephetsarath, Manilay Bouavong and David Salter

Thank You

PARTNERING
QUALITY
INTEGRITY
INNOVATE
SUSTAINABILITY
EXCELLENCE



SEACAP 21/001

**Slope stabilisation trials on Road 13N and
Road 7 in Lao PDR**

What was the project trying to achieve?

The objectives were:

- To use best-practice appropriate slope stabilisation methods using local materials and technologies
- To extend the present technologies to cover specific landslips
- To assist in the procurement and supervision of slope stabilisation trials
- To disseminate the results by means of workshops, manuals and specifications

What were the constraints?

- **Choice of sites**
- **Limited funds for construction**
- **Limited contractor capability**
- **Innovation**

- Project area about 250km north of Vientiane
- Mountainous terrain from 450m to 1450m elevation
- Annual rainfall probably more than 2000mm

Project Area

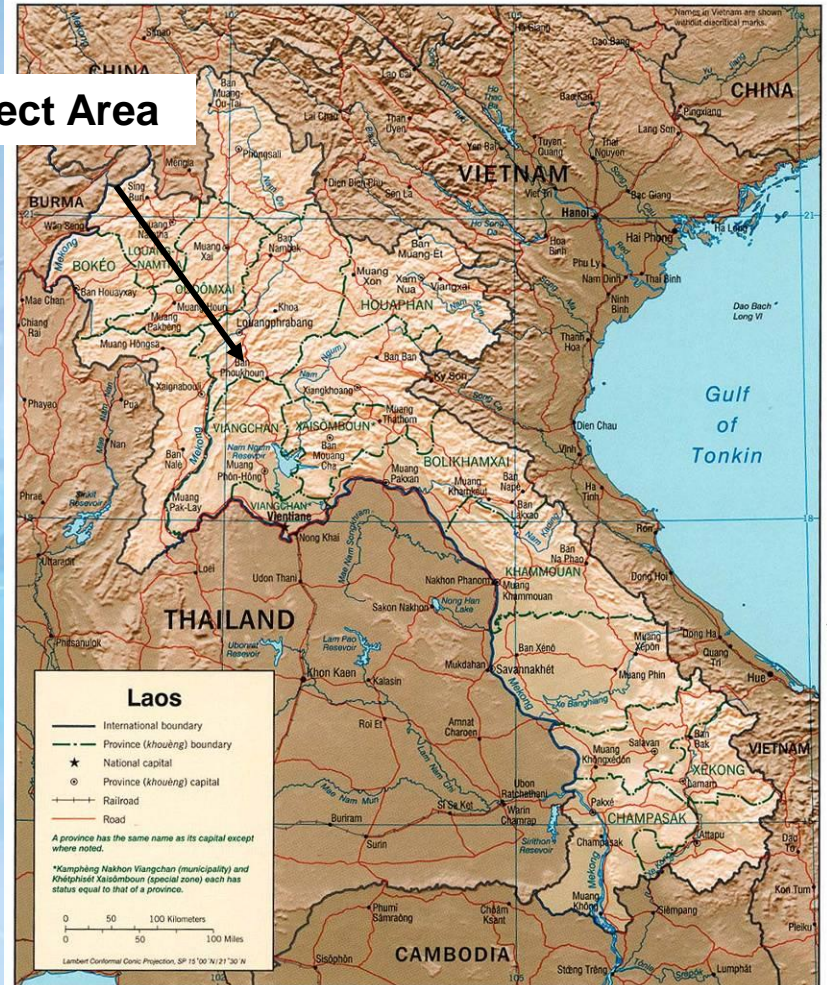

802412AI (C00140) 8-03

13 sites eventually chosen comprising a mix of failure types.

Phase 1

■ Those sites requiring mainly bio-engineering measures to prevent further instability. This comprised 3 sites, the work carried out just prior to and during the onset of the 2007 wet season.

Phase 2

■ Those sites requiring mainly geotechnical measures to prevent further instability. This comprised 10 sites, the work carried out mainly during the 2007/08 dry season.

SEACAP 21/001 PROGRAMME

Task	06	2007				2008			
Planning & Inception	■								
Design & Documents	■	■							
Approvals & Bid		■		■					
Construction			■		■	■	■		
Manuals & Training								■	

■ Phase 1

■ Phase 2

Engineering Geology Mapping

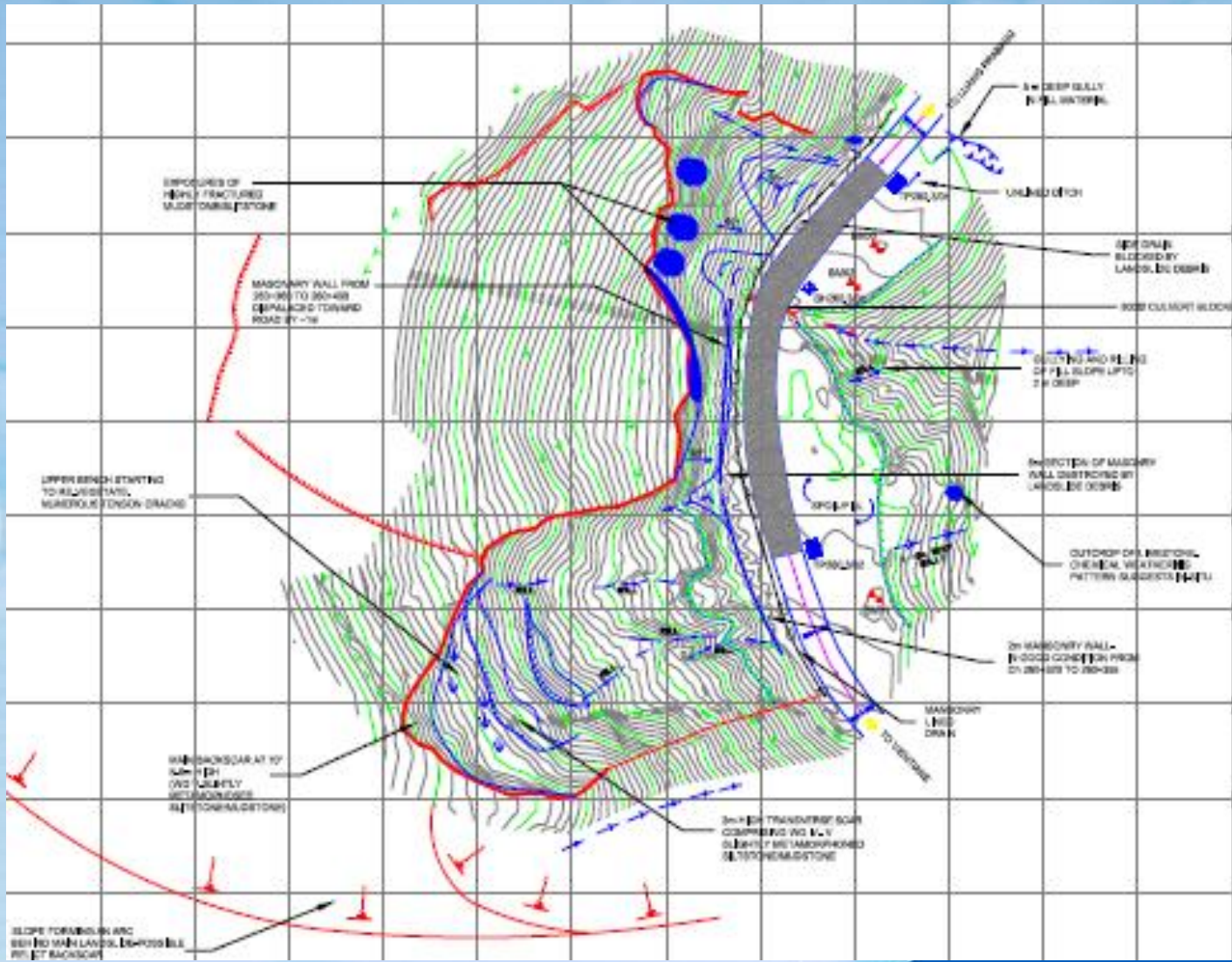

Ground Investigation



Design

Design Spreadsheet for Masonry Gravity Walls

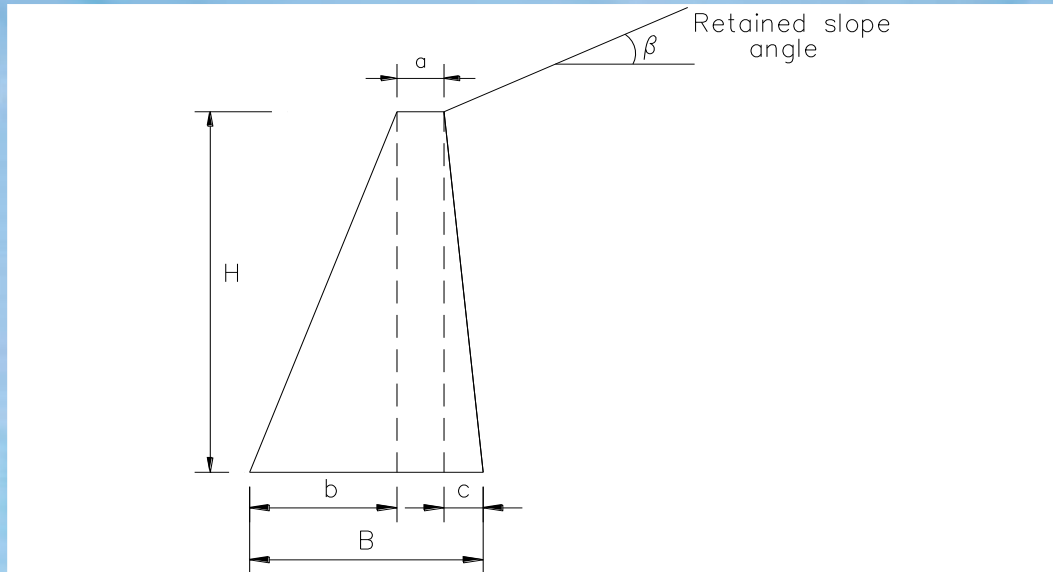

DENSITY OF WALL MATERIAL	22	kN/m ³		
PHI OF BACKFILL	30	ϕ	rad	0.523599
BACKFILL DENSITY	18	kN/m ³		
PHI OF BASE	20			
ACTIVE COEFF (Ka)	0.26			
Active Pressure	21	kN/m ²		
SURCHARGE	10	kN/m		
Back Slope Angle of Wall	95	α	rad	1.658063
WALL FRICTION	20	δ	rad	0.349066
SLOPE	0	β	rad	0

Ka	
$\sin^2(\alpha+\phi)$	0.67101
$\sin^2\alpha$	0.992404
$\sin(\alpha-\delta)$	0.965926
$\sin(\phi+\delta)$	0.766044
$\sin(\phi-\beta)$	0.5
$\sin(\alpha+\beta)$	0.996195

Section of Wall (in metres)

a	b	c	B	H
0.6	1.091	0.262	1.953	3

Construction drawings

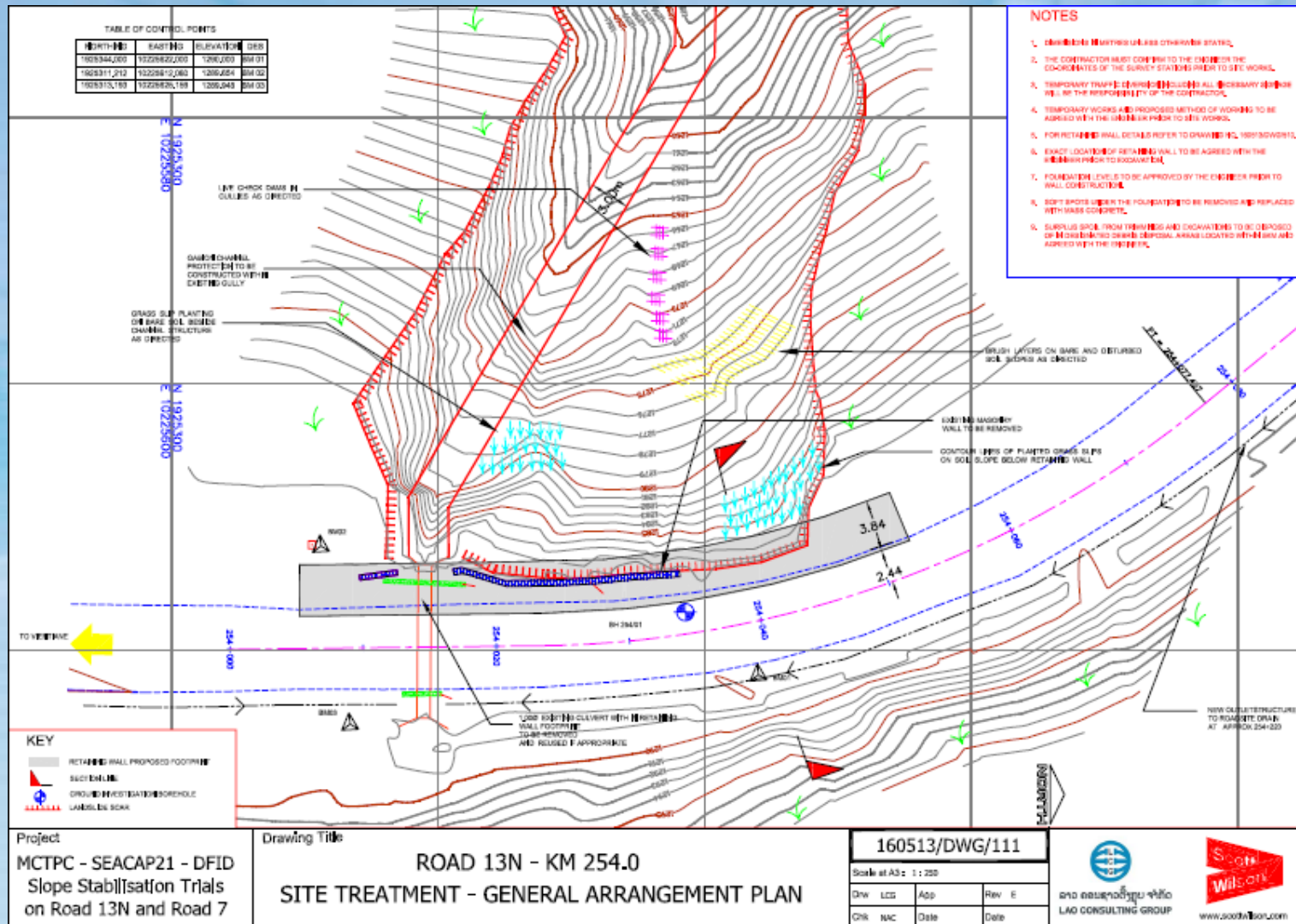

Construction



















SEACAP 21 Slope Maintenance Site Handbook

ສາທາລະນະລັດ ປະຊາທິປະໄຕ ປະຊາຊົນລາວ
ສັນຕິພາບ ເອກະລາດ ປະຊາທິປະໄຕ ເອກະພາບ ວັດທະນາຖາວອນ

ຄູ່ມືປະຈຳສະໜາມ ການສ້າງແປງຕະຝັ່ງເຈື່ອນ



ກະຊວງໂຍທາທິການ ແລະ ຂົນສົ່ງ

ກັນຍາ 2008

Slope Maintenance Site Handbook (1)

- **Written for site staff: technicians, supervisors etc.**
- **English and Lao language versions**
- **A5 size, 30 pages, illustrated mainly with photographs**
- **Structured around the MPWT's Maintenance Activity Codes.**

Slope Maintenance Site Handbook (2)

- **Definition of Maintenance for Slopes**
- **Routine Maintenance of Slopes**
- **Emergency Maintenance of Slopes**
- **Rehabilitation and Improvement.**

4.2 Construction of new walls

What are the main types of walls?

There are three main types of wall constructed in Laos: masonry, gabion and reinforced concrete. Masonry walls can be composite or fully mortared.



Mortared masonry wall



Composite masonry wall



Gabion wall



Reinforced concrete wall

Retaining walls may be constructed below or above the road. They retain the ground behind them. Revetments may also be constructed above the road.

From the road, Revetments and Retaining Walls can both look the same. The difference is that Revetments are very thin (usually only 300mm thick) and only prevent erosion and shallow sliding from occurring at the base of the slope. They are not very strong, and they do not act as retaining structures.

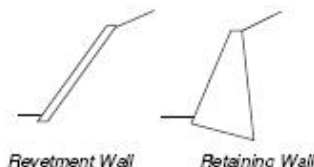

Revetment Wall

Retaining Wall

What are the advantages and disadvantages of the main types of walls?

Type	Advantages	Disadvantages
Composite masonry	Fairly cheap.	No flexibility.
	Dry stone panels very permeable	Not as strong as full mortared masonry.
Mortared masonry	Very durable.	Expensive.
		No flexibility – should always be constructed on good foundations. Limited permeability, weep holes should always be provided.
Gabion	Flexible – good where founding conditions are variable.	May be too flexible for road supporting retaining walls.
	Very permeable	Usually requires geotextile on back face to reduce fines seeping through wall.
	Cheaper than cemented masonry	Foundation may be softened by water percolating through wall. Less durable than mortared masonry. Difficult to construct if foundation uneven, although this can be overcome by using a mortared masonry layer at the base. More difficult to construct in curves in plan.
Reinforced Concrete	Very durable if good quality construction	Most expensive option
		No flexibility – should always be constructed on good foundations.
		No permeability, weep holes should always be provided

From considerations of cost, durability, appearance and strength, cemented masonry walls are generally recommended except where foundation conditions are soft or expected to move over time. In those cases, gabion walls are recommended.

What wall shape should be used?

The *Slope Maintenance Manual* discusses a number of wall shapes and their advantages and disadvantages. For simplicity, two basic wall shapes are recommended – one for cemented masonry walls and the other for gabion walls.



Mortared Masonry wall

Gabion wall

LANDSLIDE REPORT

Location (road and km):					
Date of report:			Reporter's name:		
Situation		Material		Blockage	
Above road		Rock		Whole road	
Below road		Debris		Part of road	
Through road		Soil		Side drain only	
Geometry of slipped area			Topography		
Length (m perpendicular to road)		Original slope angle			
Width (m parallel to road)		Failure angle			
Depth (m estimated)					
Estimated volume (L x W x D)		Associated retaining wall			
Sketch of failure/additional notes:					
Probable cause of failure:					
Consequences if nothing done:					

WALL CONSTRUCTION CHECKLIST – MAIN FEATURES

Safety	Done?
Have traffic warning signs been placed beside the road?	
Have barriers been placed alongside the excavation to mark out its extent? Are these clearly visible at night?	
All walls	
Have precautions been taken to prevent surface water on the road from entering the excavation?	
If excavating into the hillside, has this been done in alternate bays and the wall constructed in short lengths to prevent hillside instability?	
Is the excavated material being removed to a safe location and not dumped down the slope?	
Has the excavation level been taken deep enough to ensure that the wall is adequately founded? (The use of a DCP may help in this regard).	
Mortared and Composite Masonry walls	
Does the stone being used meet the specification for durability, size and shape?	
Is there sufficient cement in the mortar to meet the specified strength?	
Is the mortar sufficiently fluid to ensure that all the voids between the stones are completely filled?	
Have the marker blocks at the top of the wall been properly bonded into the rest of the wall?	
Gabion walls	
Is there adequate drainage from the lowest point of the excavation?	
Does the gabion wire conform to the specifications?	
Do the gabion baskets contain a transverse mesh at 1.0m centres?	
Are the stones durable and angular and with a minimum dimension not less than the gabion mesh?	
Have all the stones been carefully and densely packed into the basket?	
Have horizontal wire trusses (10 SWG or 3.25mm dia wire) been installed at 0.33m centres during filling to reduce bulging?	
Have the gabion baskets been properly connected to each other using 12 SWG (2.64mm dia) wire?	
Have the gabion baskets been staggered, as in blockwork, and with some gabions placed front to back?	
Reinforced Concrete walls	
Has the steel reinforcement been properly cleaned?	
Is there the specified cover between the reinforcement and the shuttering?	
Has the shuttering been properly secured to prevent movement during concreting?	
Does the concrete mix conform to specification?	
Has the concrete been vibrated to exclude all voids?	

ສາທາລະນະລັດ ປະຊາທິປະໄຕ ປະຊາຊົນລາວ
ສັນຕິພາບ ເອກະລາດ ປະຊາທິປະໄຕ ເອກະພາບ ວັດທະນາຖາວອນ

ຄູ່ມືການສອ້ມແປງຕະຝັ່ງເຈື່ອນ



ກະຊວງໂຍທາທິການ ແລະ ຂົນສົ່ງ

ກັນຍາ 2008

SEACAP 21 Slope Maintenance Manual

Slope Maintenance Manual

- **Written for road management professionals: engineers**
- **English and Lao language versions**
- **A4 size, 110 pages, illustrated with drawings, photographs, typical details**
- **Covers all relevant aspects of site inspection, design and construction**

Technical Specifications

- **Complete technical specifications for slope stabilisation and protection**
- **English and Lao language versions**
- **Based on international experience and best practices**
- **Tested through SEACAP 21 trials and modified accordingly**

Innovation?

- **Approach to problem: site assessment, hazard ranking, ground investigation, design, construction**
- **Bio-engineering: several techniques**
- **Wall design and construction: masonry and gabion**
- **Drainage: roadside, wall, slope**
- **Manuals: Comprehensive manuals written in Lao and English**

SEACAP 21/003

Mainstreaming Slope Stability Outcomes

What are the aims of the project?

The objectives are:

- **To integrate the SEACAP 21 outputs into the core engineering courses of the National University of Laos**
- **To field trial the SEACAP 21 approaches, design manuals and specifications within MPWT**

NUoL

- **Review and assess undergraduate engineering core curriculum**
- **Recommend revisions as necessary**
- **Draft outlines for potential undergraduate and graduate thesis studies, and any new relevant courses**
- **Include interested students and faculty members in the field trials**

MPWT

- **Select six sites representing typical slope stability problems along Roads 13N and 7**
- **Field trial approaches, design manuals and specifications to preliminary design status**
- **Carry out in-service training for MPWT and provincial counterparts during survey and design activities**



SEACAP 21

END OF PRESENTATION