

**OVERSEAS
ROAD NOTE
11**

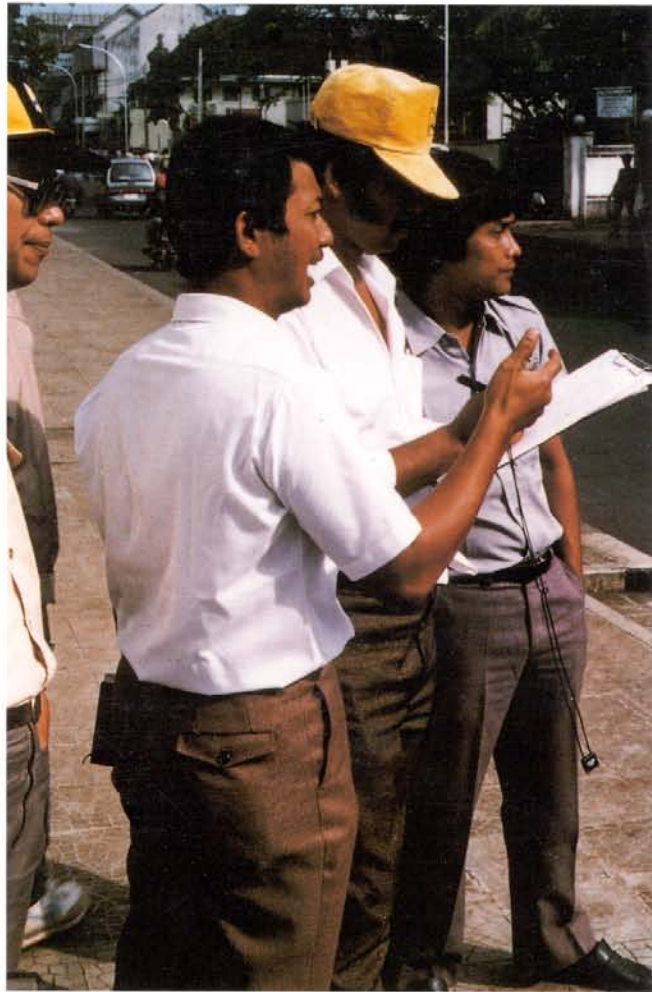

***Urban Road
Traffic Surveys***



Overseas Centre
Transport Research Laboratory, Crowthorne, Berkshire, United Kingdom

© 1995 TRL



Old Wokingham Road
Crowthorne
Berkshire
RG11 6AU



Overseas Development Administration
94 Victoria Street
London
SW1E 5JL

OVERSEAS ROAD NOTE 11

URBAN ROAD TRAFFIC SURVEYS

Main subject area: Urbanisation/Transport, energy efficiency

Theme: Urban Transport

Project title: Urban Road Traffic Surveys

Project reference: ODA/2.3

This document is an output from an ODA-funded research project, carried out for the benefit of developing countries.

Crown copyright 1993. The views expressed in this report are not necessarily those of the Overseas Development Administration or the Department of Transport.

Overseas Centre, TRL, 1993
ISSN 0951-8987

ACKNOWLEDGEMENTS

This note is based on a draft commissioned by the Overseas Centre (Programme Director: Dr. J. Rolt) and prepared by the Institute for Transport Studies, Leeds University. The authors were Mr N W Marler and Mr F O Montgomery, with the assistance of Prof. A D May and Mr P W Bonsall. Mr G Gardner, TRL was Project Officer. It has been edited for inclusion in the Overseas Road Note series by Mr P Disney, an independent consultant, and Mr G Gardner, Dr J C Rutter and Mr P R Fouracre. The material is based on experience gained by this team working with many overseas institutions, notably the Institute of Technology, and the Institute of Road Engineering, Bandung, Indonesia, the Training College of the Department of Land Transport, Jakarta, Indonesia, the Asian Institute of Technology and Chulalongkorn University, Bangkok, Thailand.

OVERSEAS ROAD NOTES

Overseas Road Notes are prepared principally for road and transport authorities in countries receiving technical assistance from the British Government. A limited number of copies is available to other organisations and to individuals with an interest in roads overseas. Enquiries should be made to

Transport Research Laboratory
Crowthorne, Berkshire RG11 6AU

© Crown Copyright 1993

Limited extracts from the text may be reproduced, provided the source is acknowledged. For more extensive reproduction please write to

Head of Overseas Resource Centre,
Transport Research Laboratory.

CONTENTS

	Page		Page
1. Introduction	1	9. Junction delay surveys	32
Scope and objectives	1	Stopped vehicle count method	32
The need for surveys	1	Method	32
		Output	35
2. Survey planning	3	Elevated observer method	35
General considerations	3	Method	35
Road classification system	3	Output	35
Vehicle classification system	3		
Traffic variation and sampling	3	10. Saturation flow	35
Fieldwork preparation	3	Flow profile method	38
Human resources	3	Saturation period method	38
Equipment	7	PCU values	41
Survey forms and instructions	7		
Pilot survey	7	11. References	41
Liaison with other agencies	7		
Surveyor safety	7	Appendix A: Summary statistics and	
Data handling	7	sample size	43
Processing and error checking	9	Appendix B: General checklist for	
Analysis	9	survey supervisors	45
		Appendix C: Instructions for surveyors	
3. Road inventory surveys	10	and bank survey forms	46
4. Parking surveys	10		
Parking inventory survey	13		
Parking patrol survey	13		
Output	13		
5. Origin and destination surveys:			
Registration number method	17	A Supervisor's log	
Method	17	B Link inventory	
Output	18	C Junction inventory survey	
		D Parking beat survey	
6. Traffic volume and classification surveys	18	E Parking survey summary	
Manual traffic counts	18	F Registration number plate survey	
Automatic traffic counts	22	G Traffic flow survey	
Equipment	22	H Traffic data summary form	
Combatting equipment errors	25	J Speed survey along measured baseline	
		K Journey time survey from moving vehicle	
7. Spot speed surveys	25	L Delay survey by counting stopped vehicles	
Radar speed guns	25	M Delay survey from vantage point	
Manual short-base method	27	N Saturation flow profile survey	
Output	27	P Saturated period count	
8. Network speeds and delay surveys	29		
Method	29		
Number of runs, routes and			
timing points	29		
Output	32		

LIST OF SURVEY FORMS

(see Appendix C)

A	Supervisor's log
B	Link inventory
C	Junction inventory survey
D	Parking beat survey
E	Parking survey summary
F	Registration number plate survey
G	Traffic flow survey
H	Traffic data summary form
J	Speed survey along measured baseline
K	Journey time survey from moving vehicle
L	Delay survey by counting stopped vehicles
M	Delay survey from vantage point
N	Saturation flow profile survey
P	Saturated period count

1 INTRODUCTION

SCOPE AND OBJECTIVES

1.1 This manual provides traffic engineers with a guide to simple, reliable traffic survey techniques, suitable for urban road traffic in developing countries. It covers surveys for **urban traffic engineering**, but does not cover **road safety or transport planning**. Public transport surveys are described in Overseas Road Note No 4 (TRRL, 1987) and road safety issues in TRRL (1990).

1.2 The manual consists of three parts: in chapter 2 general issues concerning traffic surveys are discussed; chapters 3 to 10 each describe a specific survey, and the appendices contain detailed instructions and survey forms for supervisors and surveyors. While the manual is written for the left-hand rule of the road, it can be used in countries which drive on the right, though the diagrams will need to be transposed and the accompanying text interpreted accordingly.

1.3 The surveys described in the manual are considered sufficiently robust for use in most urban situations, though it may be necessary for some small modifications to meet specific local needs and conditions. Account must be taken of any existing government guidelines and legal requirements which concern, or could have an impact on, the implementation of traffic surveys.

THE NEED FOR SURVEYS

1.4 Surveys are required for both national and strategic traffic issues, and for local traffic planning, engineering and management purposes. Traffic data are important to a wide range of decision-making processes in the planning, construction, operating and maintenance of the transport system. Information is needed to support not only the case for transport investment (infrastructure planning, design and construction), but also to indicate how to make best use of existing road facilities (traffic management and maintenance policy).

1.5 The traffic data required from surveys is of transport supply (inventories and characteristics of the vehicles and infrastructure which comprise the system), transport demand (the amount the system is used and the patterns of movement) or performance (how well the system accommodates the demand placed upon it, measured in terms of traffic speeds, journey times and delay). Table 1.1 lists the main types of survey that are further described in subsequent chapters. The collection of traffic data is organised either as part of general background monitoring of traffic developments or as part of a detailed traffic investigation.

1.6 Traffic monitoring is the consistent and regular (periodic or continuous) surveying of traffic data, either nationally or locally, for a range of planning purposes: to calculate historical trends, in supply, demand and performance; to calculate hourly, daily, and seasonal variation factors; to provide a summary of the existing

system, in terms of supply, demand, and performance, and identify existing problems; to determine the timing and sample rate of further surveys; as a base for predicting future demand and performance, in order to plan improvements.

1.7 Detailed data collection is required for the investigation of specific problems, the design of improvements, and for 'before and after' evaluation of the impact of changes. 'Before and after' surveys are a special type of monitoring to gauge the effects of a specific action. 'After' surveys should be carried out long enough after implementation of the scheme to allow new traffic patterns to become fully established (typically 2-4 weeks), but not so long as to allow underlying traffic trends to affect the outcome. It is also desirable to carry out simultaneous 'control' surveys in a different part of the city, to reveal any underlying changes to traffic conditions.

TABLE 1.1

Survey types

Type (Chapter)	Information	Method	Output
Road inventory (3)	Road network Characteristics	Observation	Geometry, Land-use, Road-furniture provision
Parking inventory (4)	Parking supply	Observation	Available parking space Types of parking
Parking use (4)	Demand for Parking space	Parking patrol survey	Occupancy times, Usage of space
Origin-destination (5)	Demand forecasting	Registration Number method	Route choice Through-traffic Travel times
Traffic volumes (6)	Demand	Manual counts, Automatic counts	Vehicle flows on links, Junction movements, Passenger flows, Traffic variability, Peak-hour factors, AADT
Spot speeds (7)	Vehicle performance on links	Short-base method, Radar observation	Vehicle speeds on links, Speed flow measurements
Network speeds and delays (8)	Route network performance	Floating car method	Network speeds, Link speeds, Network delay, Congestion points
Junction delay (9)	Junction performance	Stopped vehicle count, Elevated observer method	Total delays, Average arm delays, Distribution of delay times by turning movement, Delay causes
Saturation flows (10)	Junction capacity	Flow profile method, Saturated period count	Saturation flow, Junction capacity

2 SURVEY PLANNING

GENERAL CONSIDERATIONS

Road classification system

2.1 Roads have two basic, but possibly conflicting, functions: to move traffic smoothly and without interruption, and to provide access. The provision of access will often necessitate interruption to traffic flow, hence the conflict. The function of any specific road, therefore, is a balance between these two extremes, and is defined by a road hierarchy (see Fig 2.1). The concept of road hierarchy is fundamental to safe and efficient traffic operations and planning. The classification of a road's function within the hierarchy should also have a significant effect on its design standards (geometry, structure, etc.). Therefore it is important in any study of the traffic network to describe the road links in terms of their classification within the hierarchy. Fig 2.2 shows a possible classification system which should be amended to suit local conditions (Institution of Highways and Transportation and the Department of Transport, 1987).

Vehicle classification system

2.2 A fully comprehensive classified count may identify up to 20 different vehicle types. It is rare that such detail will be required, however, and in order to minimise survey difficulties, five groups will often be sufficient based upon the sub-groups shown in Fig 2.3. The group or category number is based on the number of tyres on the vehicle.

2.3 Sub-divisions should be chosen to include groups of common interest. For example, in a transport planning study, divisions may be according to vehicle occupancy; for a road damage study, they may be by vehicle weight; and for traffic signals studies they may be according to their passenger car unit values (see Chapter 10). Each class must be distinguished from the others by a unique characteristic which can be seen easily in a moving traffic stream on a busy street. For example, methods which involve the counting of the number of tyres are more reliable than those which require estimation of length or weight. For clarification, a sketch or photograph of vehicle types should always be given to survey staff.

Traffic variation and sampling

2.4 Traffic variations are usually cyclical, and may be hourly, daily, or seasonal. The most appropriate days and times of survey depend on survey objectives (for example, whether average values or peak values are required). Surveys should not be conducted when traffic flow is affected by abnormal conditions, such as accidents, roadworks, public holidays, public processions, and severe weather conditions (particularly heavy rain).

Separate measurements may be required for seasonal rainy and dry periods. A particular problem in developing cities is that interruptions to traffic flows can be so common as to be considered part of the normal traffic scene. In this case the influence of the disruption should be noted, along with the traffic performance values being evaluated.

2.5 The aim of any survey should be to collect only as much data as is required to give an estimate at the desired level of accuracy. Appendix A gives detailed guidance on the use of simple statistical procedures to help choose the sample size.

FIELDWORK PREPARATION

Human resources

2.6 A traffic engineer develops the general requirements into a work plan and programme. He must choose the appropriate survey method for the task and conditions, and decide on locations and times. He must also ensure the correct preparation and training of both Supervisor and Surveyors.

2.7 Survey Supervisors undertake the surveys with teams of Surveyors. There should be no more than 10 Surveyors per Supervisor; larger teams are difficult to manage. The Supervisor must ensure the accuracy of observations and recording, timekeeping and completion of survey form headings. He must also support the survey team in general, by maintaining the supplies of forms, materials, and equipment. He also records changes in traffic conditions (for example, accidents, weather, traffic controls) using a log (Appendix B).

2.8 Shift lengths depend upon the intensity and rate of work, as well as any legal constraints or government recommendations on working hours. In surveys with a high work-rate (for example recording vehicle registration numbers) attention spans are relatively short, and shifts should be broken up into sessions of half an hour to one hour, with short breaks in between. In general, shifts should be too short rather than too long; no Surveyor should be asked to do more than is comfortably possible.

2.9 One Surveyor, however competent, should *never* be required to record more than twelve items (for example, three classes of vehicle and four turning movements). Two-way traffic is regarded as two items, even if not recorded separately. As a rule of thumb, one experienced surveyor using a pencil and appropriate form can simultaneously record:

- twelve items, up to a flow of 300 veh/hr.
- four items, up to 600 veh/hr.
- two items, up to 1200 veh/hr.
- one item up to 1800 veh/hr

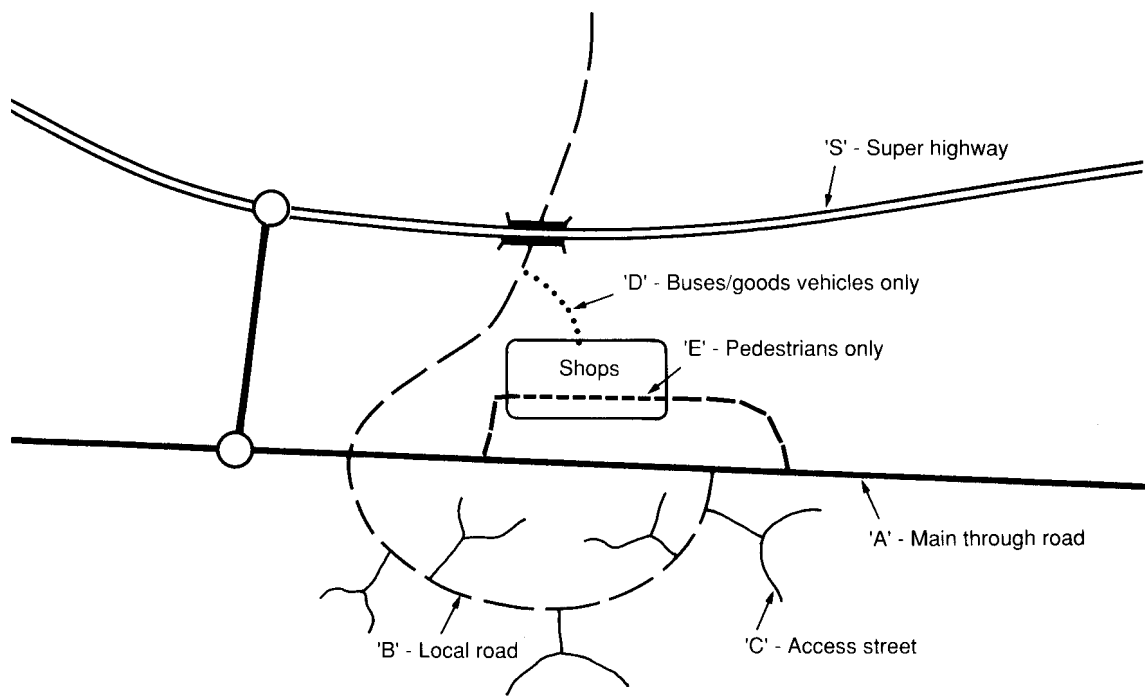
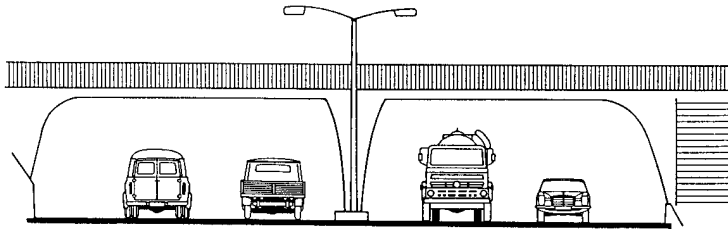

Figure 2.1 Example of a road hierarchy

Figure 2.2 Road Categories and Function

S = Super Highway



A = Main Roads

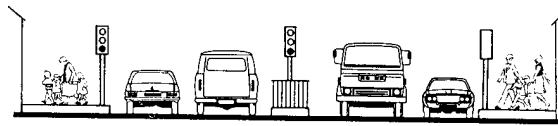

B = Local Roads

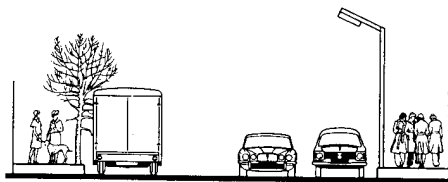

C = Access Streets

(D = Controlled access streets, including bus only streets, with similar profile)

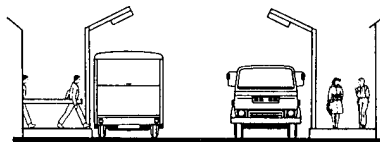

































E = Pedestrian Streets



(adapted from Institution of Highways and Transportation and the Department of Transport, 1987)

Figure 2.3 Simplified Vehicle Classification

CATEGORY	SUB-CAT	NAME	EXAMPLES
2	B	Bicycle	Adult  Child  Etc 
	M	Motorcycle	Motorcycle  Moped  Scooter 
3	R	Leg powered Rickshaw	Pushing  Pulling  Pedalled Freight Transport 
	A	Auto Rickshaw	Scooter Rickshaw  Other Powered 3-Wheeler 
4	C	Cars & Light Vans	Car  Private Mini-Bus  All vans with only 4-tyres 
	T	Taxis & Paratransit	Taxi  Jeep  Pick-up  Micro-Bus  Mini-Bus 
5+	P	Public Transport	Double Decker  Single Deck Bus or Coach with 20+seats  Passenger vehicles with more than 4-tyres 
	G	Goods Vehicles	Rigid  Articulated  Trailer  All Vehicles with more than 4 tyres 
L		Leg Powered	Hand Cart  Animal Cart 
	O	Other	Tractor  Earth Mover  Tram Car  Other 

Drawn by: G. Holland T.O.R.G. University of Newcastle upon Tyne. 1993.

Rates for inexperienced Surveyors should be about two-thirds of these values.

For high volume flows in excess of 1800 veh/hr the use of tally counters will help. Other, less satisfactory techniques include counting in groups of ten, and creating sub-divisions of items for separate Surveyors to monitor (e.g. counting by lane or subdividing the vehicle categories).

2.10 Survey duration should be sub-divided so that anomalies can be identified by comparing different short periods, and discussed with the Surveyors involved. For example, even if the required data from a survey is the 1 hour total volume, it should be divided into 15 minute periods.

Equipment

2.11 Lists of equipment and materials are included with the individual survey instructions. The Supervisor must specify the equipment needed by each Surveyor; again, space is provided for this purpose on the Supervisor's field logsheet (see Appendix B).

2.12 Watches are used extensively in traffic surveys. It is recommended that digital chronometer watches which can display hour, minute, and second simultaneously be used for all timing tasks. (Stopwatches are not recommended as they are prone to operator error.) All watches should be individually numbered and each should be checked against a reliably accurate standard from time to time.

Survey forms and instructions

2.13 Survey form design should be simple, with enough space to record the data easily even under busy field conditions. Margins at left, right, and bottom of the form should be large enough to allow it to be clipped to a board, and filing holes to be punched, without obscuring information. Heading information should include the project title, survey type, and blank spaces for the Surveyor to enter the exact location (e.g. road name), a sketch plan showing the site and location of the surveyor (with measurements to an accuracy of 50m), date and time, Surveyor's name, weather conditions during the survey, and any other information concerning unusual traffic conditions.

2.14 Each Surveyor and Supervisor must have clear, detailed written instructions and training for each survey form and each individual task. This will include a detailed description of each individual task and how the survey form(s) should be filled in, with examples. It should be impressed upon them that every single item of header information must be completed on every sheet. To avoid ambiguity it should also be emphasised that no box or column is ever left blank; value zero is shown by the

figure zero (not a dash), and suitable abbreviations are used for 'not available' (n/av), or 'not applicable' (n/app). Appendix C contains instructions and blank forms for each of the surveys described in the following chapters.

Pilot survey

2.15 Pilot surveys are full field tests of a survey method, preferably at the location of the main survey itself. Though they are sometimes omitted for reasons of economy, experience has shown that pilot surveys are a vital part of ensuring acceptable data quality. They can also help plan sample size and survey duration, thus ensuring the most effective use of available time and money. If the pilot is well prepared, and proves to be successful, the pilot survey data may become part of the main data set.

Liaison with other agencies

2.16 The approval of the police may be required for any activity on the highway, and their permanent presence may be necessary for some types of survey. However, as far as possible, the police must be made aware that there should be no unusual police presence or activity in the survey area which could affect the traffic characteristics being measured in the survey (for example, additional enforcement of speed limits).

Surveyor safety

2.17 Any work close to moving traffic has potential dangers. All survey staff should have suitable insurance cover, and each individual should be given a verbal briefing on traffic safety precautions as well as a copy of the safety card (fig 2.4) or similar. There may be legal obligations on the part of the survey organisers in respect of safety; these must be established and adhered to.

DATA HANDLING

2.18 Data processing converts raw field data into a standard format, from which summary statistics, tables, and graphs can be prepared. Analysis is the process of drawing conclusions from this data. Both processing and analysis should begin as soon as possible, because potential errors are more easily identified and corrected if the surveyor concerned can be questioned. Also, additional surveys are more easily organised, if required. The main types of mistake are incorrect application of random or systematic sampling, measurement errors (misreading or misrecording, usually arising from Surveyors being required to record more information than can comfortably be achieved, use of ambiguous definitions or lack of adequate Surveyor training) and blunders (the result of direct human error). Measurement errors are often

SAFETY CARD

Although you may be working on an important project, remember that your safety comes first.

ALWAYS

- STAND IN A PLACE WHERE NO VEHICLE CAN HIT YOU

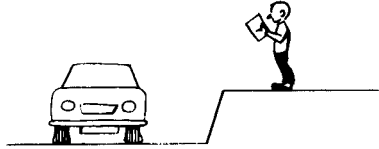

- DO NOT CROSS THE ROAD WITHOUT LOOKING



- FIND SHELTER FROM EXTREMES OF WEATHER



- TAKE PLENTY OF WATER



- AVOID CONFRONTATION



I have taken a copy of this safety card and accept that I must take responsibility for my own safety.

Signed

Name in full

Figure 2.4 Safety card

difficult to detect later. Serious blunders are usually detectable if proper data checking procedures are followed. However, every attempt should be made to avoid measurement errors and blunders from the start, as many errors cannot be identified once the data are collected.

Processing and error checking

2.19 Data processing usually involves the transfer of raw data from the field sheets onto summary sheets or directly into computer files. This transcription process itself can be a major source of error and must be carried out with care. The transcriber should also remain alert to the possibility that the data contain errors, and report any observations which appear to be in error. With computer records it is easy to make specific error checks at the first stage of data processing. The most obvious check is for data to be entered twice, independently, and compared for differences.

2.20 The traffic engineer should look for unusual values or patterns in lists, tables, diagrams, and graphs. Discussion of unusual results with the Supervisors is often very productive. For example, a traffic volume histogram may show a large fluctuation from one 15 minute period to the next. There are no fixed rules, but an investigation could be carried out as follows:

- consider what reasons could have caused the fluctuation, for example, an effect such as that shown in the log.
- consider whether the Surveyor forgot to change time periods every 15 minutes, resulting in periods being longer or shorter than 15 minutes. The Surveyor should be questioned about this and the original survey forms examined. If this was the cause, the effect could be reduced by combining 15 minute periods into, say, one hour periods instead.
- compare existing data from other surreys, to see if the effect was present at adjacent locations at the same time; at the same location, at the same time; at the same location and time on different days.
- if no other data exist, carry out an additional (short) check survey at the same location and time of day.
- if no clear conclusion emerges, a judgement must be made on whether the data should be included in the analysis.

When an error is suspected in an individual measurement, it should be corrected or discarded. It should be corrected only if the correct value is known with reasonable certainty. It is important not to throw away data just because it might be in error: stronger evidence is needed. In most studies a few extreme values will not materially affect the results. However, in studies interested mainly in extreme values (for example, observance of speed limits) the treatment of extreme values needs to be rather more

thorough, and include a visual assessment of a histogram of all the data.

2.21 Data processing resource needs (excluding analysis) vary considerably between different types of surveys. As a rule of thumb, processing time can take about twice the time of field data collection. Computers do not necessarily speed up procedures as much as might be expected, though direct entry of observations into a hand-held computer clearly has the promise of much reduced processing time.

Analysis

2.22 Analysis seeks to draw conclusions relevant to the study objectives from the data characteristics and trends established in the surreys. Statistical techniques can be used to indicate, for example, whether there is a relationship between variables under examination or whether a significant difference has resulted from a particular road treatment. However, the analysis cannot, of itself, say anything about causes; why does one variable respond to a change in another or why a particular treatment has had some success? It is the job of the traffic engineer to design surveys which will yield data that can be used to test and quantify a hypothesis. To demonstrate, for example, that higher speeds result from a road widening the survey must be designed to screen out all possible alternative factors (different traffic flows, weather conditions, etc.). The use of control survey data may be a powerful tool in this analytical process.

3 ROAD INVENTORY SURVEYS

3.1 The road infrastructure consists of links, junctions, parking spaces and terminals. The physical characteristics which will influence its use include its current geometrics and pavement structure, its traffic controls (signs, signals, road markings, and parking restrictions), sidewalks, shoulders, adjacent land use, service provision (for example, gas, water, electricity, telephones) and the intensity of non-traffic activities which encroach upon road space (for example, hawkers, builder's materials, market stalls etc.). The purpose of the inventory survey is to record this information.

3.2 The detail of an inventory survey can be varied to suit needs. Form B is adaptable to meet different levels of detail. An approximate, but simple survey method involves Surveyors walking or driving along a link, and locating objects or points by the distance (chainage) along the link and the off-set from the centre line. Chainage can be taken from a vehicle odometer or measured by pacing, or measuring wheel. As far as possible, inventory Surveyors should be restricted to observation and measurement, as opposed to making any judgements. Fig 3.1 shows an example of a completed survey form demonstrating the level of detail which can be recorded.

3.3 Junctions generally require a more detailed approach than links with, for example, measurements of corner radii and turning restrictions. Form C can be used, supplemented by additional material in sections X and Y. Traffic signal information should normally be collected in a form consistent with the equipment manufacturer's specifications.

3.4 The rate of progress of an inventory survey obviously depends upon the data items to be noted and the accuracy of measurements. However a simple link survey for traffic planning purposes should progress at approximately 0.5 - 1.0 km/h. Link surveys can be carried out by pairs of Surveyors, one surveying to the left of the centreline, and the other to the right.

3.5 The field sheets themselves are the main output from the survey. They should be filed and referenced to a master map showing the area covered by each field sheet. Individual road links and junctions can be related to a network, by a system of link and node numbering. Existing link/node numbers should be used if these exist (for example for accident reporting or signal maintenance) as this will permit ease of cross-referencing with other survey material. Fig 3.2 shows an example in which the system chosen has 2-digit numbers for nodes, and 3 digits for links; this allows for extra nodes (Nos 51 & 53 for example) to be added if required.

4 PARKING SURVEYS

4.1 Parking surveys provide the data upon which the parking policy for an area can be decided. The provision of parking is obviously a major factor, primarily for private cars, in the accessibility of an area. Parking management is also a most effective low-cost traffic policy instrument

4.2 Car parking spaces can be classified into: on-street or off-street; public (i.e. available to the public) or private; formal (i.e. marked and controlled spaces) or informal. Parking and stopping spaces must also be provided for commercial vehicles (primarily delivering and collecting freight) and public transport vehicles (for picking up and setting down passengers). Other characteristics of parking are: dimensions and layout (including access roads); time controls; charges and costs; banned and restricted locations.

4.3 Parking demand characteristics include:

- accumulation: the number of parked vehicles in an area, at any given moment. A graph showing the variation of accumulation in a city centre during the day, can be compared with the parking supply to show when there is over- or under-provision of parking space.
- parking duration: the time one vehicle remains parked in one place.
- parking load: the total demand on an area over a period of time, measured in vehicle-hours. It is the sum total of all vehicle durations, (equal to the area under the accumulation graph).
- parking volume: total number of vehicles using the parking facilities over a period of time (usually one day).
- turnover: rate of use of parking spaces, calculated by dividing the parking volume by the number of spaces.
- arrival and departure rates: which affect the design of entry and exit facilities, particularly for off-street car parks.

4.4 Two surveys are described here: parking inventory surveys, which determine the existing supply, by recording the number and location of spaces; parking patrol surveys which monitor demand and are usually for on-street (kerbside) parking but can be used for off-street facilities. The two are usually undertaken together.

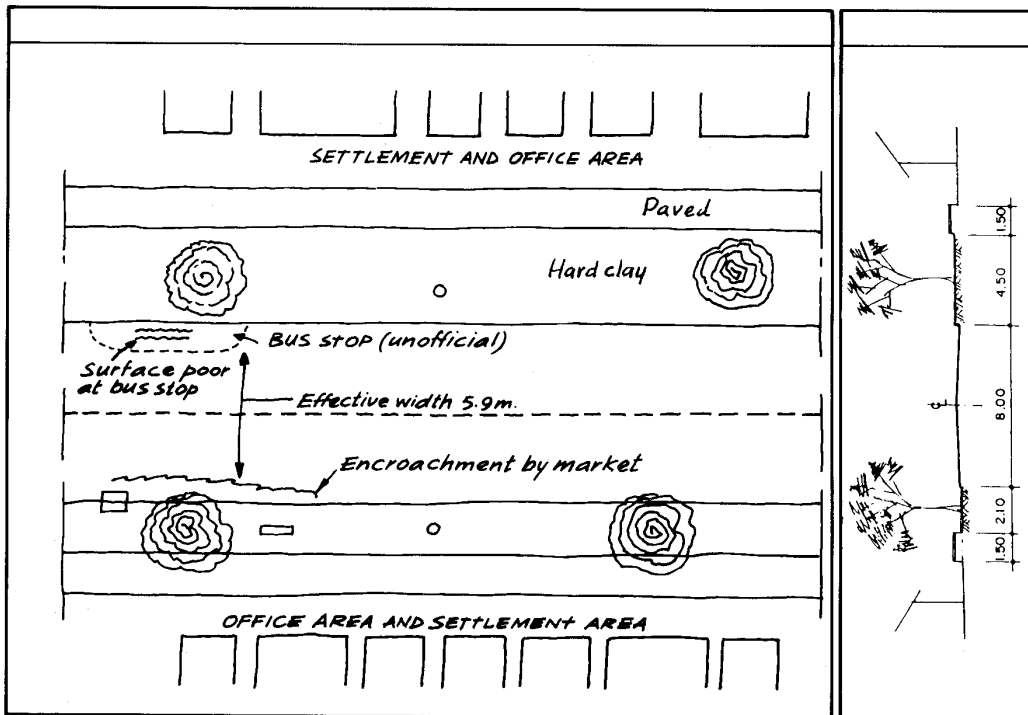

CHECKLIST

Pedestrian facilities – islands, bridges, etc –	<i>None</i>
Public Transport – stops (including informal) –	<i>As indicated, mainly para-transit</i>
Street lights – height and colour of bulb –	<i>None (some white fluorescent on outside of offices) Generally dark due to trees.</i>
Encroachments – permanent or temporary –	<i>As shown - Small market mainly from baskets not barrows.</i>

Figure 3.1 An example of a completed link inventory form

PARKING INVENTORY SURVEY

4.5 This survey requires a base map, upon which the surveyor marks the location and number of parking spaces. The map should be approximately 1:500 scale, depending upon the amount of detailed information to be recorded. A sketch map is perfectly adequate (Fig 4.1, for example), but officially published maps may be preferred. The parking inventory may also be incorporated into the road link and junction inventory maps. Where more than one form is required for a study area, a master reference map of the study area will be necessary, showing the area covered by each sketch sheet.

4.6 The location and number of formal parking spaces is usually determined easily because the spaces are marked. The number of informal parking spaces requires some judgement. Kerbside car parking spaces can be assumed to be 6 metres long and 2.5 metres wide. For informal areas, it is necessary to count the actual number of parked vehicles at a time of peak demand.

PARKING PATROL SURVEY

4.7 Surveyors patrol a predetermined route, with a predetermined number of parking spaces. The patrol is divided into a number of sections. Surveyors record the location of all parked vehicles, their registration number, and vehicle type using Form D which can be modified to allow the type of parking to be recorded on the form, by providing an additional column alongside the vehicle registration number.

4.8 The area to be surveyed is decided from study objectives and the parking spaces within that area are identified from a parking inventory survey. In addition to public spaces, the survey can include private, informal (e.g. waste ground), and illegal spaces (footpaths, no-parking areas), as required.

4.9 The patrol interval depends on whether parking at that location is short or long stay, but is typically 15 minutes. With low turnover, the patrol interval can be as long as 45 - 60 minutes; with high turnover 15 - 20 minutes is more appropriate. Preliminary data can be obtained from a pilot survey. The patrol interval should include an allowance of 5 minutes for rest and contingencies.

4.10 The length of route is determined by the patrol interval (less 5 minutes), together with the Surveyor's walk speed. Typical walk speed is 20 metres/minute, although it depends on the amount of data the surveyor has to record; high turnover means more data and a slower speed. If parking accumulation is required without associated duration, only the total number of each type of vehicle parked in each section needs to be recorded on each patrol. Therefore less data is collected, walk speeds are increased, and considerably longer routes are possible. Alternatively, data can be collected from a car, although a driver will be required.

4.11 Routes should be defined to end at the start point, so that the surveyor wastes no time in returning to the starting point. A simple circuit may be defined by a Surveyor walking up one side of a street and back on the other.

Routes are sub-divided into sections, typically of 20 spaces, to allow the identification of sections with different characteristics (for example duration, turnover). Section boundaries should occur where characteristics are expected to change, for example with change of adjacent land use from offices to shops. Data is then summarised by section.

Output

4.12 Vehicle arrivals, departures and accumulation can be calculated and entered into the boxes on the survey form itself and summarised on Form E. Parking duration is estimated by noting the patrol time at which each registration number was first seen, and the time at which it was last seen. The same result is obtained by counting the number of observations of a particular vehicle registration, and multiplying by the patrol interval. Note, however, that if the vehicle is present on the first or last patrol only a minimum duration can be calculated. Different vehicle types (or parking types) can be dealt with separately. Figs 4.2 and 4.3 show a worked example of a parking survey.

4.13 Bar charts can be drawn to summarise the parking duration pattern, if necessary by vehicle type. If examination of these indicates this is warranted, bar charts for adjacent sections can be combined.

Unrestricted parking space
 ~~~~~  
 No. of spaces: ⑩  
 Parking prohibited  
 ←————→  
 or totally unsuitable

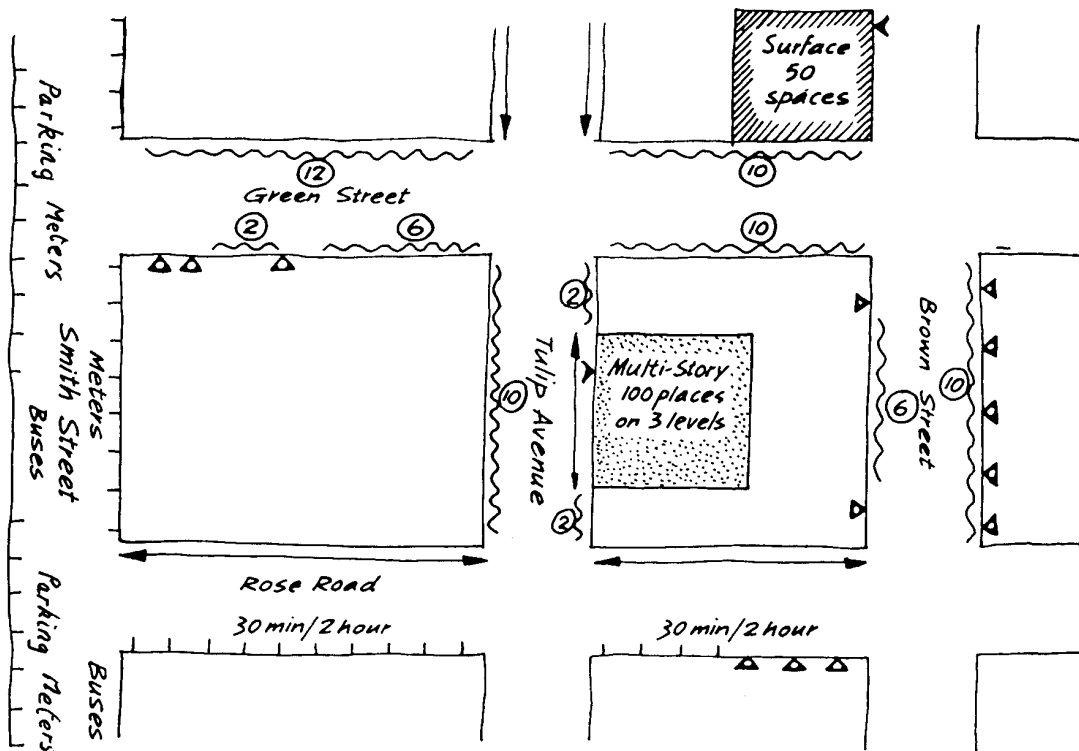
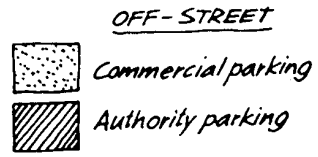
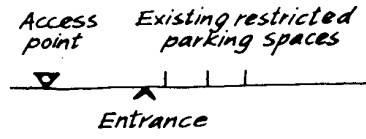
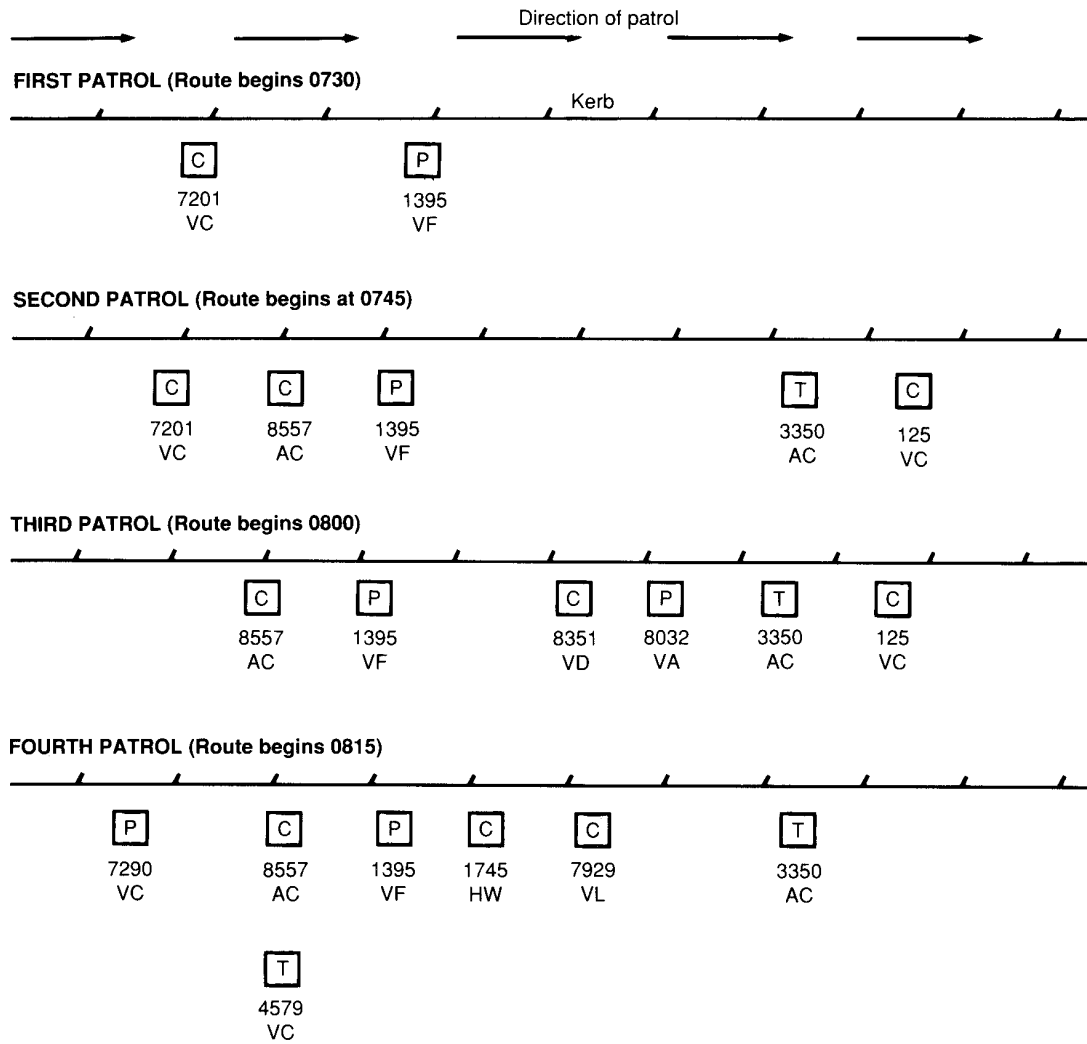

Figure 4.1 An example of a Parking Inventory Survey

(From Wells, Traffic Engineering - An Introduction)

EXAMPLE PLAN OF FOUR SUCCESSIVE PATROLS ALONG THE SAME SECTION OF STREET



Notes: Vehicle types: Car = C; Pick-up = P; Truck = T;

Figure 4.2 Parking patrol: example

Figure 4.3 Parking Patrol Survey form: Example

| Registration Number | Time at Start of Route          |    |    |    |    |    |    |    |    |    |    |   |    |    |    |    |    |    |    |    |    |    |    |   |    |    |    |   |
|---------------------|---------------------------------|----|----|----|----|----|----|----|----|----|----|---|----|----|----|----|----|----|----|----|----|----|----|---|----|----|----|---|
|                     | hh                              | mm | V  | hh | mm | V  | hh | mm | V  | hh | mm | V | hh | mm | V  | hh | mm | V  |    |    |    |    |    |   |    |    |    |   |
|                     | 07                              | 30 | V  | 07 | 45 | V  | 08 | 00 | V  | 08 | 15 | V | 08 | 30 | V  | 08 | 45 | V  | 09 | 00 | V  |    |    |   |    |    |    |   |
| 1                   | 72                              | 01 | VC | C  | 72 | 01 | VC | C  | 85 | 57 | AC | C | 72 | 90 | VC | P  | 72 | 90 | VC | P  | 72 | 90 | VC | P | 72 | 90 | VC | P |
| 2                   | 13                              | 95 | VF | P  | 85 | 57 | AC | C  | 13 | 95 | VF | P | 85 | 57 | AC | C  | 85 | 57 | AC | C  | 85 | 57 | AC | C | 45 | 79 | VC | Ⓣ |
| 3                   |                                 |    |    |    | 13 | 95 | VF | P  | 83 | 51 | VD | C | 45 | 79 | VC | Ⓣ  | 45 | 79 | VC | Ⓣ  | 45 | 79 | VC | Ⓣ | 22 | 23 | VL | C |
| 4                   |                                 |    |    |    | 33 | 50 | AC | T  | 80 | 32 | VA | P | 13 | 95 | VF | P  | 13 | 95 | VF | P  | 13 | 95 | VF | P | 33 | 50 | AC | T |
| 5                   |                                 |    |    |    | 12 | 5  | VC | C  | 33 | 50 | AC | T | 17 | 45 | HW | C  | 22 | 23 | VL | C  | 22 | 23 | VL | C | 13 | 95 | VF | P |
| 6                   |                                 |    |    |    |    |    |    |    | 12 | 5  | VC | C | 79 | 29 | VL | C  | 79 | 29 | VL | C  | 33 | 50 | AC | T |    |    |    |   |
| 7                   |                                 |    |    |    |    |    |    |    |    |    |    |   | 33 | 50 | AC | T  | 33 | 50 | AC | T  | 12 | 34 | VD | P |    |    |    |   |
| 8                   |                                 |    |    |    |    |    |    |    |    |    |    |   |    |    |    |    |    |    |    |    |    |    |    |   |    |    |    |   |
| 9                   |                                 |    |    |    |    |    |    |    |    |    |    |   |    |    |    |    |    |    |    |    |    |    |    |   |    |    |    |   |
| 10                  |                                 |    |    |    |    |    |    |    |    |    |    |   |    |    |    |    |    |    |    |    |    |    |    |   |    |    |    |   |
| 11                  |                                 |    |    |    |    |    |    |    |    |    |    |   |    |    |    |    |    |    |    |    |    |    |    |   |    |    |    |   |
| Total               | 2                               |    | 5  |    | 6  |    | 7  |    | 7  |    | 7  |   | 5  |    |    |    |    |    |    |    |    |    |    |   |    |    |    |   |
| New Arrivals        | N/APP                           |    | 3  |    | 2  |    | 4  |    | 1  |    | 1  |   | 0  |    |    |    |    |    |    |    |    |    |    |   |    |    |    |   |
| Departures          | N/APP                           |    | 0  |    | 1  |    | 3  |    | 1  |    | 1  |   | 2  |    |    |    |    |    |    |    |    |    |    |   |    |    |    |   |
| Notes               | ← Heavy rain → ← rain stopped → |    |    |    |    |    |    |    |    |    |    |   |    |    |    |    |    |    |    |    |    |    |    |   |    |    |    |   |

(Circled letters indicate double-parked vehicles)

Parking Patrol Data Reduction Form: Example

| Reg. No. | Vehicle Type | was there at* |     | first seen | number of times seen | Duration (min)** |         |
|----------|--------------|---------------|-----|------------|----------------------|------------------|---------|
|          |              | start         | end |            |                      | known            | unknown |
| 7201 VC  | C            | Y             | N   | 07 30      | 2                    |                  | > 15    |
| 1395 VF  | P            | Y             | Y   | 07 30      | 7                    |                  | > 90    |
| 8557 AC  | C            | N             | N   | 07 45      | 5                    | 75               |         |
| 3350 AC  | T            | N             | Y   | 07 45      | 6                    |                  | > 75    |
| 125 VC   | C            | N             | N   | 07 45      | 2                    | 30               |         |
| 8351 VD  | C            | N             | N   | 08 00      | 1                    | 15               |         |
| 2223 VL  | C            | N             | Y   | 08 30      | 3                    |                  | > 30    |
| 1234 VD  | P            | N             | N   | 08 45      | 1                    | 15               |         |
| TOTALS   |              |               |     |            | 37                   | 195 / 7          |         |

\*if yes in either column, duration is unknown in which case duration is greater than (number of times seen - 1) X observation period

\*\*number of times seen X observation period

total number of different vehicles   
 average known stay (minutes)

percentage greater than  mins =  %  
 percentage less than  mins =  %

## 5 ORIGIN - DESTINATION SURVEYS: REGISTRATION NUMBER METHOD

5.1 Origin-destination (O-D) data is used to analyze the effect of proposals for change (for example, a new traffic management scheme, or a new road) on travel through a study area. The O-D data is kept constant, but routes and journey times can be changed; the impact of the proposal on individual trips and cumulative volumes, travel times, and costs can be assessed. O-D data is usually presented as a matrix of trip volumes between each origin and destination. The origin and destination points are the start and end zones of a trip, but can also be the entry and exit points on the study area cordon.

5.2 O-D information can be derived from home or roadside interviews, postcard and sticker surveys and by registration number plate surveys. For long term transport planning studies, and large urban areas, where it is important to establish the social and economic characteristics of transport users, interview surveys are best. Registration number plate surveys obtain less information, but are easier to implement and are suitable for determining existing patterns of movement in small study areas.

5.3 For this manual, surveys dealing only with local area traffic schemes are considered. The Registration Number Method is an observation survey which matches the number plates of vehicles which enter and exit the defined study area, in order to accumulate an O-D matrix. If observers are scattered throughout the study area, as well as at the cordon, the method can also be used to obtain large samples of travel time data between observation points and to determine routing of individual vehicles through the study area.

5.4 The main problems with registration number surveys are that many reliable surveyors are needed, survey planning and coordination is complex and data processing and analysis are complicated and time-consuming (computerisation of the registration-matching process is almost essential).

### Method

5.5 Surveyors record the registration numbers of vehicles in-bound and out-bound to the study area, together with the time of observation and class of vehicle, if required. Two Surveyors are required at each observation point, one for each direction of traffic flow. Additional Surveyors can be located at intermediate points inside the study area, providing further information on routing and travel time. Each sighting of a vehicle provides more information on its travel time and routing, and possible stops inside the study area.

5.6 The study area should be as small as possible consistent with study objectives, in order to minimise the

number of Surveyors needed and to minimise the amount of data processing. The study area is defined by a cordon which should be drawn in such a way that vehicles entering or leaving the area cross the cordon only once.

5.7 Usually it is not possible to record the registration numbers of all vehicles, so in practice a subset of the total flow is chosen. It is important that the subset is chosen such that Surveyors at all points can record 100 per cent of the subset; it is much better to record 100 per cent of a small subset than, say, 85 per cent of a larger one. The proportion which the subset forms of the total flow must be known.

5.8 The most common method of choosing a sub-set is to use the last digit of the vehicle registration number. If any number between 0 and 9 is equally likely to occur, then the choice of any number automatically results in a 10 per cent subset. If two numbers are chosen, then a 20 per cent subset is selected. The last digit is chosen because it is most likely to be a random number. The method is simple, but requires every number plate to be scanned before deciding whether it has to be recorded.

5.9 Alternatively, vehicle colour can be used to distinguish the subset provided that the colour is not ambiguous; red is a poor choice, ranging from maroon to orange. Grey and white are often sufficiently unambiguous. (The pilot study should be used to check Surveyors' recognition of the colour.) Selection by colour can bias the results; for example, black is unambiguous, but there are few black cars in most cities and many of these may be official vehicles. Two (or more) colours may be used to provide a sufficient sample. If vehicle colour is used, the simultaneous volume count must also be classified by colour (as well as vehicle type) for expansion purposes.

5.10 To avoid any cause for doubt, it is recommended that the whole registration number (letters and numbers) should be recorded in full. Form F is used to record the information. It is also possible to record data on either a tape recorder or hand-held microcomputer. For tape recorders the information is recorded verbally, doubling the rate of data acquisition because the surveyor does not take his eyes off the traffic. However, transcription can take longer than the survey itself, and other problems arise from equipment failure etc. Hand held microcomputers record time automatically, which if required makes recording twice as fast as using pencil and paper. If time is not to be recorded, then they do not have this advantage and are also subject to equipment failure problems.

5.11 An experienced Surveyor can record up to 300 registration numbers (of four numbers and three letters) per hour, using pencil and paper. The rate varies according to local conditions, the type of registration number, the size of the plate and numerals, etc. The rate will be lower with inexperienced personnel and if other information is recorded; for example, time of observation reduces the rate by more than 50 per cent and vehicle type, reduces the rate by about 20 per cent. A pilot survey will help establish work rates.

## Output

5.12 The survey begins at the same time at all locations, so that just after the start of the survey vehicles will be leaving the area which were not recorded entering it. Furthermore, just before the finish, vehicles enter the area which will not be recorded leaving it. These vehicles should be ignored to obtain a clear picture of the proportion of through traffic. The easiest way to remove most of them from the data set is to estimate the average time ('n' minutes) it would take to cross the survey area without stopping and to discard all registration numbers of vehicles which left or entered the area within 'n' minutes of the start or finish of the survey. This is done before matching takes place.

5.13 Computer processing is recommended for matching all registration numbers between each entry and exit point pair, which have a positive travel time. The output file should list the entry point, exit point, registration number, (if used) vehicle type, entry time, and journey time. Assuming no errors, vehicles entering the study area will have been matched to an exit point, except for vehicles which either entered during the survey and stayed in the area until after the survey was finished or which were in the area when the survey started but left during the survey. These vehicles form part of the "stopping" traffic discussed below.

5.14 To identify stopping vehicles a histogram (Fig 5.1), is drawn of the travel times between each entry and exit point. The vehicles with the shorter travel times represent the non-stopping traffic, and the "tail" of longer travel times are for those vehicles which stopped in the area for some reason. It is necessary to decide the boundary between the two types. A simple rule is best employed, and applied to all cases: for example, using the first gap in the histogram longer than one minute.

5.15 For the whole area, non-stopping traffic can be expressed as a proportion of total traffic in the survey period, total traffic being all (non-stopping and stopping) matched vehicles plus the unmatched vehicles discussed. Knowing the sample proportion, it is simple to factor the sample data to give an estimate of the total flows of non-stopping traffic.

## 6 TRAFFIC VOLUME AND CLASSIFICATION SURVEYS

6.1 The purpose of these surveys is to collect data on the number and types of vehicles passing a specified point on a link (link counts), or making specified movements at a junction (turning counts). The occupancy of vehicles may also be recorded to provide data on the volumes of people using the roadspace. Volume of traffic is expressed as a rate of flow, usually either as vehicles per hour (veh/h), in particular the peak hour demand on the road, or vehicles per day (veh/day), often converted into the value "AADT" (Annual Average Daily Traffic).

6.2 By definition AADT can be known definitively only from a continuous count over a full year. However, factors for modifying short period counts to estimate AADT can be developed using long period counts for a limited number of sites which are chosen to represent the main types of road in the network. The annual counts at the sample sites will indicate seasonal, daily and hourly variation and hence the factors which relate traffic volumes (measured at any specific time) to the AADT, for that class of road.

6.3 In urban areas peaks in traffic demand arise primarily because of home-to-work trips, occurring typically at the beginning and end of the normal working day. The 'peak hour factor' expresses peak hour volume on a route as a proportion of the AADT. The peak hour factor for a particular route is often a consideration in classifying routes by type. As a rule of thumb, on urban roads the peak hour traffic is usually around 10 per cent of AADT (Note that the US Highway Capacity Manual defines peak hour factor in a different way - TRB, 1985).

6.4 Examples of presenting traffic volume data are shown in Figs 6.1 and 6.2. These include: volume maps, with a geographical background overlaid by bandwidths representing traffic volumes (see Fig 6.1 a); desire line diagrams, more often used for Transport Planning Studies, but which can also be useful in the planning stages of local area traffic surveys (Fig. 6.1 b); junction turning movements (see Fig 6.2).

6.5 Traffic volume surveys are carried out by either manual or automatic traffic counts. Manual counts are particularly useful for vehicle classification, checking automatic counter accuracy, and surveying vehicle occupancy. Automatic traffic counts, using traffic counter equipment, are normally used only on links, and are particularly suitable for long-term data collection, and analysis of seasonal, daily, and hourly variations. In most studies, a combination of automatic and manual counts is needed.

### MANUAL TRAFFIC COUNTS

6.6 In a manual count a surveyor stands by the roadside, counting and classifying the vehicles as they pass, dividing the survey into fixed time periods. It is normal for the surveyor to record only one direction of flow.

6.7 Link counts should be located on straight sections of road for good visibility. Duration can be from a few minutes to several days, depending on purpose. Most counts are carried out for one day, starting before the morning peak hour, and extending for 12, 14 or 16 hours. Count periods are usually 15 minutes, with results summarised hourly. Shorter periods may be used for special purposes. Even when hourly counts are the most detailed data required, 15-minute periods should be used as errors are more easily identified (particularly start-up and close-down errors).

6.8 Turning movement counts are carried out in the same manner as link counts, except that the turning movement of each vehicle is recorded, and the vehicle

**Figure 5.1 Example of a Registration Plate Matching Survey Data Reduction**

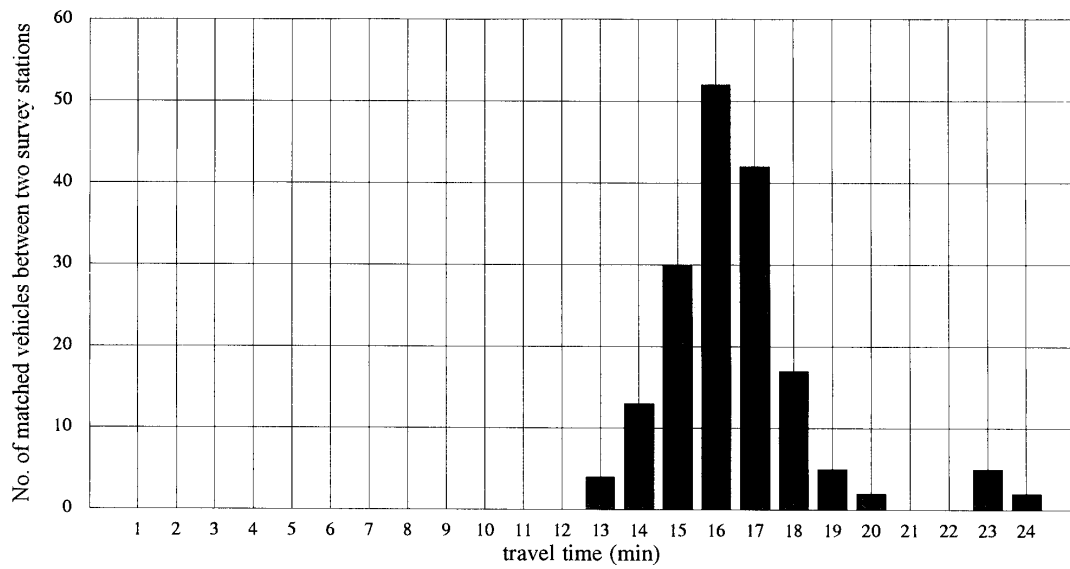
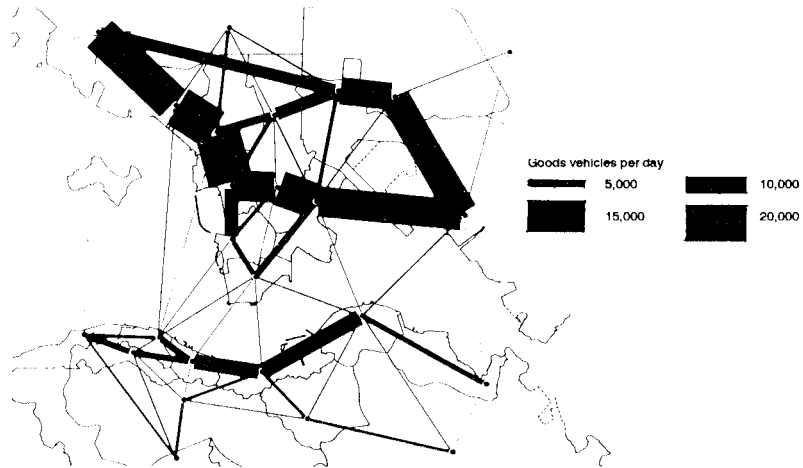
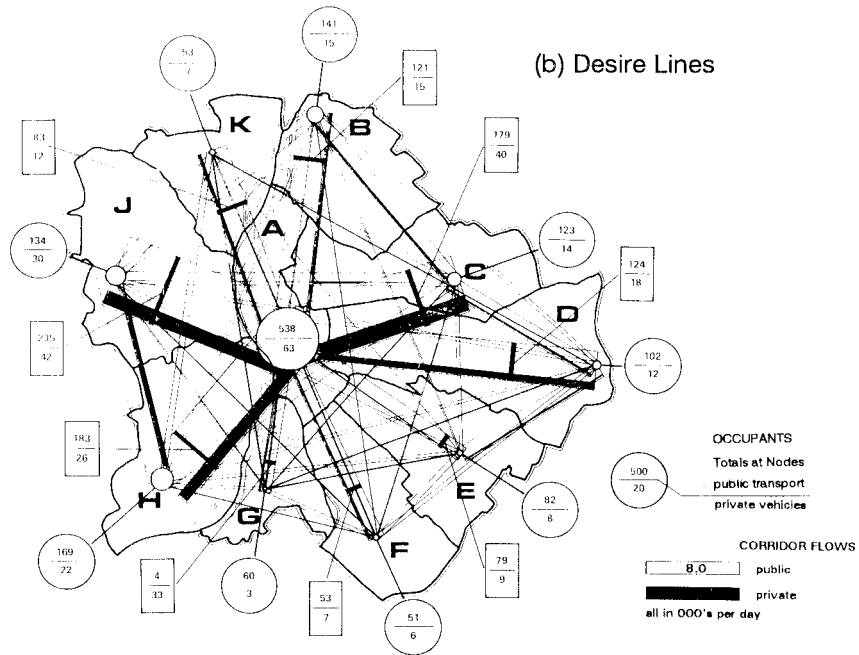

Figure 6.1 Presentation of Network Traffic Data

(a) Traffic Flow Diagram



(b) Desire Lines



Note: Diagrams shown are from city-wide transport planning studies.

Figure 6.2 Presentation of Junction Count Surveys

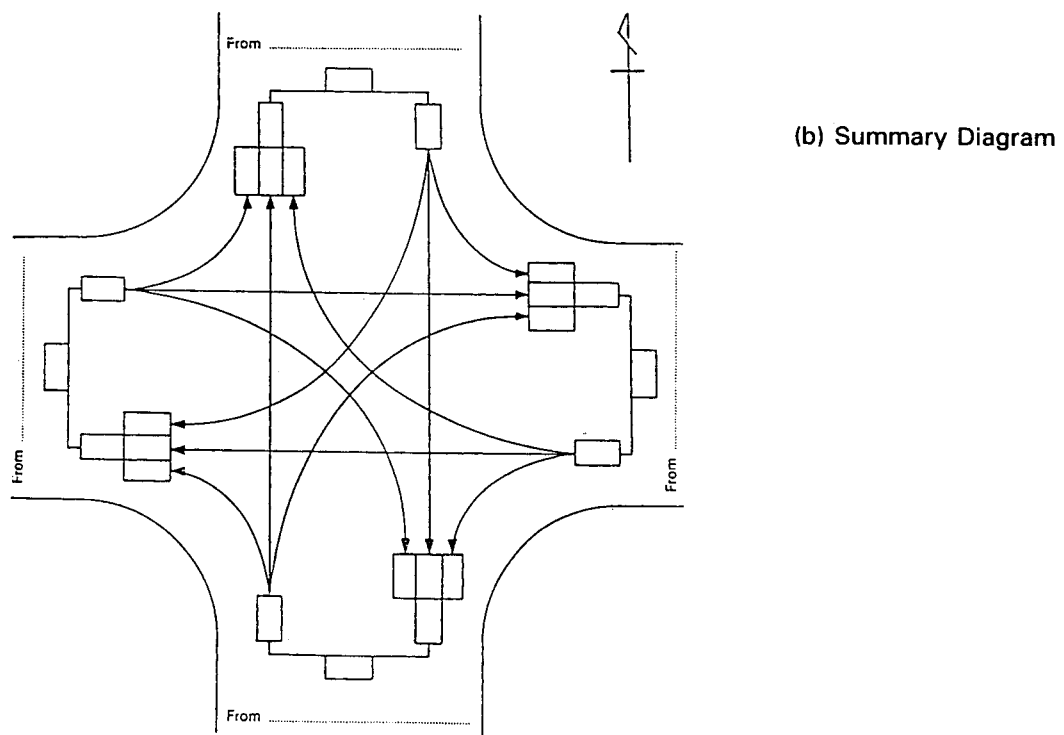
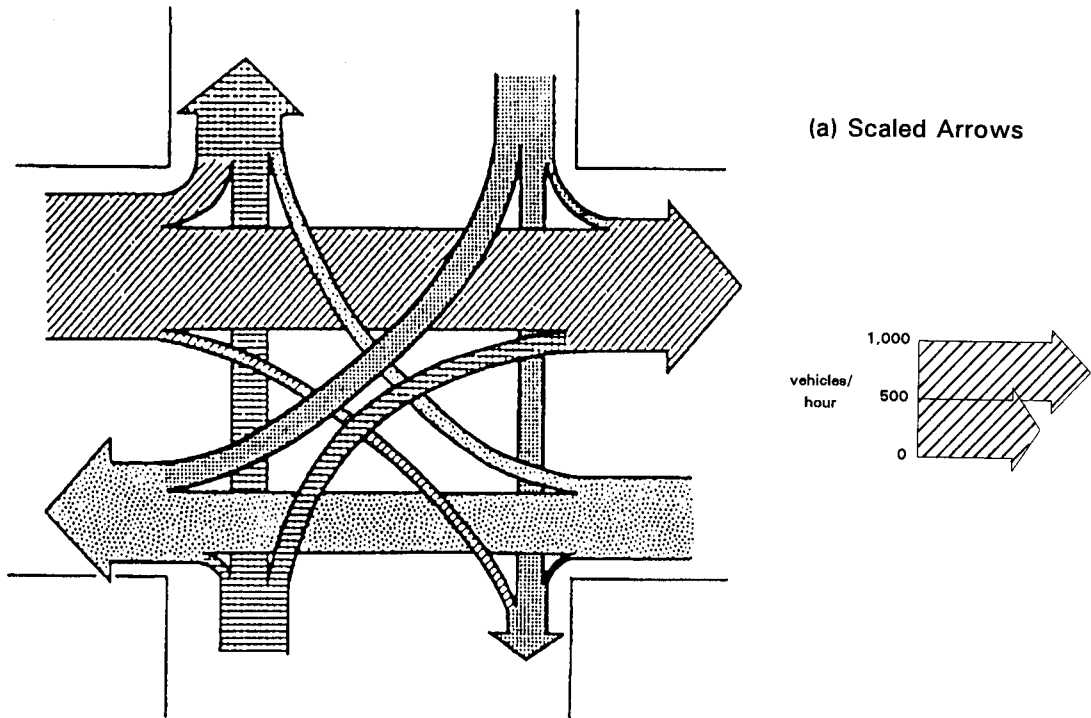

classification system is simplified (to compensate for the extra demands on Surveyors). These surveys are primarily concerned with the performance of the junction during peak periods, and survey duration is often confined to the morning and afternoon peak periods, typically between 2 and 4 hours each. Count periods are usually 15 minutes. However, at signalised junctions short-term volumes are determined by signal operations, and cycle times in excess of 2 minutes, or count periods less than 15 minutes, may cause apparent fluctuations in flow. In such cases it is best to record flow for each cycle, using the cycle time as the counting period.

### Survey forms

6.9 Survey forms must be designed for the specific needs of the study, but Form G is a good base. Typical examples of completed field forms are shown in Fig 6.3 which also illustrates the three common pencil-and-paper methods of recording and classifying each vehicle. The 'five-bar gate' method is the most versatile and is applicable to both link and turning counts. It records data quickly (without the need for extreme neatness), is the most economical in use of space on the survey form and can be summarised quickly. The 'initial letter' method is appropriate for surveys with short periods of high flow, when field manpower is limited. It has the fastest rate of data recording where one surveyor must record several items and is very fast for counts in only one direction, as the Surveyor's need to look down at the survey form is limited. It does require longer processing time than other methods, neatness to distinguish the symbols and more processing manpower. The **'crossing out numbers' method** is best with low or medium continuous flow. It is the least flexible of the methods and has the slowest recording rate. However, there are no problems of Surveyors 'losing count', and totalling is immediate.

6.10 Alternatively, hand tallies can be used to record specific vehicle classes. They are faster and more accurate than pencil and paper methods, because only the total is recorded, at the end of each count period, and the surveyor is looking at the traffic flow almost continuously. However, vehicles can be missed while recording the cumulative total at the end of each count period. Note that tally counters should not be reset at the end of each time period as this wastes too much time, rather the cumulative total should be recorded at the end of each period. Tallies are also subject to mechanical failure and should be checked regularly; a common fault is not registering every vehicle.

6.11 Errors with manual counts usually arise from one of three sources: failure to define vehicle classification unambiguously, which can lead to undetected errors; failure to observe time periods accurately; surveyors having to count vehicles at a faster rate than they are capable. Particular attention should be given to these problems during the pilot survey.

## AUTOMATIC TRAFFIC COUNTS

### Equipment

6.12. Automatic traffic counter equipment (Fig 6.4) consists of a detector, to detect the vehicle, and a counter to record the information. The most common types of detector used in traffic counting are a hollow rubber pneumatic tube, held to the road surface by special clips, or an inductance loop (several turns of wire laid on or in the road surface in a rectangular or diamond shape).

6.13 Pneumatic tubes detect the movement of a vehicle as the tube is depressed by a tyre; this creates a pulse of air which closes a diaphragm in the recorder adding one axle (usually half a vehicle) to the counter total. Tubes should be installed in accordance with the following guidelines:

- the count site must not be located where braking or acceleration occurs, or where overtaking is common, such as near junctions, bus stops, or other parking locations.
- the count site must not be located near areas where children play or walk to school, as children are tempted to tamper with the counter or tube.
- at the count site the road should be straight, level, and free from flooding.
- the tube must be fixed at right angles to the direction of traffic flow.
- the tube must be straight when fixed, and it should be stretched some 10 per cent to ensure it remains straight.
- the tube must be clamped firmly to the road, with at least one clamp per lane of traffic, plus one near each kerb.
- the counter should be securely locked to a pole or tree, but the tube must not cross a footpath.
- the tube and counter must be checked frequently for damage or malfunction.

Pneumatic tube detectors record axles, and the counter assumes that two axles equals one vehicle. This overestimates the number of vehicles, and a correction factor should be applied, calculated from classified count data (short sample count if necessary, but including both peak and off-peak data), as follows:

$$\text{Correction Factor} = \frac{\text{Number of vehicles}}{\frac{1}{2} \times \text{Number of axles on those vehicles}}$$

A correction factor is calculated for a specific site, but various sites can be averaged to produce factors for an area, or different classifications of roads.

Figure 6.3 Alternative Methods of Traffic Counts

(a) Five Bar Gate

| Overseas Unit, TRL, Crowthorne, UK |       |       |               |                                                  | Form G       |        |
|------------------------------------|-------|-------|---------------|--------------------------------------------------|--------------|--------|
| SITE NAME                          |       |       | Site Ref. No. | Surveyor(s) & Supervisor                         |              | Sketch |
| VICTORY RD                         |       |       | 1037          | GG .JT & JCR                                     |              |        |
| Date                               | Time  |       | Weather       | NOTES                                            |              |        |
| 4.8.93                             | 08:00 | 08:15 | Dry & sunny   | Actual start time 8:02 due to illness (see note) |              |        |
| ARM NAME                           |       |       | DIRECTION     |                                                  |              |        |
| VICTORY RD WEST                    |       |       | BOTH          |                                                  |              |        |
| ← TO AIRPORT                       |       |       | TO Centre →   |                                                  | — NOT used — |        |
|                                    |       |       |               |                                                  |              |        |
|                                    |       |       |               |                                                  |              |        |

(b) Initial Letter Method

| Overseas Unit, TRL, Crowthorne, UK |       |       |                 |                                                          | Form G     |        |
|------------------------------------|-------|-------|-----------------|----------------------------------------------------------|------------|--------|
| SITE NAME                          |       |       | Site Ref. No.   | Surveyor(s) & Supervisor                                 |            | Sketch |
| STATION RD / ALBERT RD             |       |       | 0075            | GG JCR                                                   |            |        |
| Date                               | Time  |       | Weather         | NOTES                                                    |            |        |
| 7.12.93                            | 08:00 | 09:00 | Rain after 8.35 | Slight flooding outside bus station - reduced road width |            |        |
| ARM NAME                           |       |       | DIRECTION       |                                                          |            |        |
| STATION RD                         |       |       | EAST            |                                                          |            |        |
| ↖ TO NORTH                         |       |       | ↑ TO EAST       |                                                          | ↗ TO SOUTH |        |
| 08:00:                             | CCM   | CCH   | MCC             | CCCC                                                     | CCC        | CCMEMB |
| 08:15                              | BCCC  | B     |                 | MM                                                       |            |        |
|                                    |       |       | BB              |                                                          |            |        |

(c) Crossing out Numbers

| Overseas Unit, TRL, Crowthorne, UK |      |      |               |                                                                 | Form G |             |
|------------------------------------|------|------|---------------|-----------------------------------------------------------------|--------|-------------|
| SITE NAME                          |      |      | Site Ref. No. | Surveyor(s) & Supervisor                                        |        | Sketch      |
| HIGH FARM                          |      |      | 02            | GG - GG                                                         |        |             |
| Date                               | Time |      | Weather       | NOTES                                                           |        |             |
| 4.8.93                             | 0800 | 0900 | V. HOT        | Roadworks 1km to North may cause diversion away from this site. |        |             |
| ARM NAME                           |      |      | DIRECTION     |                                                                 |        |             |
| HIGH FARM DRIVE                    |      |      | BOTH          |                                                                 |        |             |
| Two Wheeled Motor Vehicles         |      |      |               |                                                                 |        | Sheet       |
|                                    |      |      |               |                                                                 |        | 22 23 24 25 |
| Cars and Taxis                     |      |      |               |                                                                 |        | Sheet       |
|                                    |      |      |               |                                                                 |        | /of         |

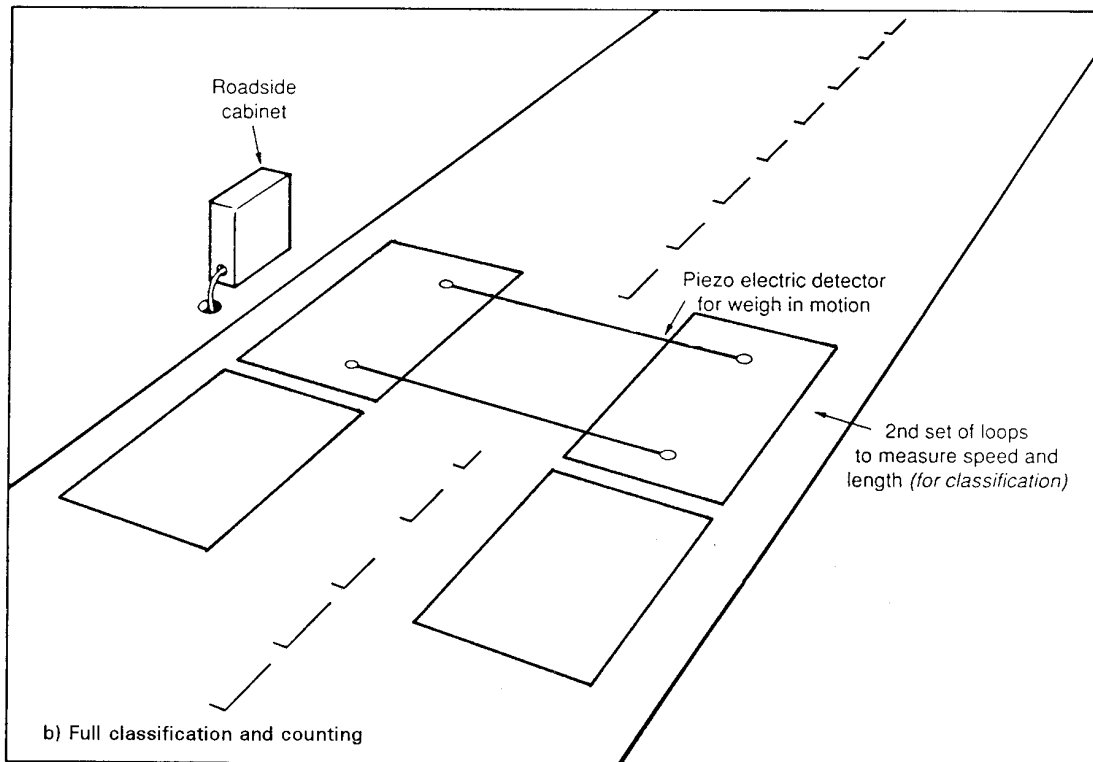
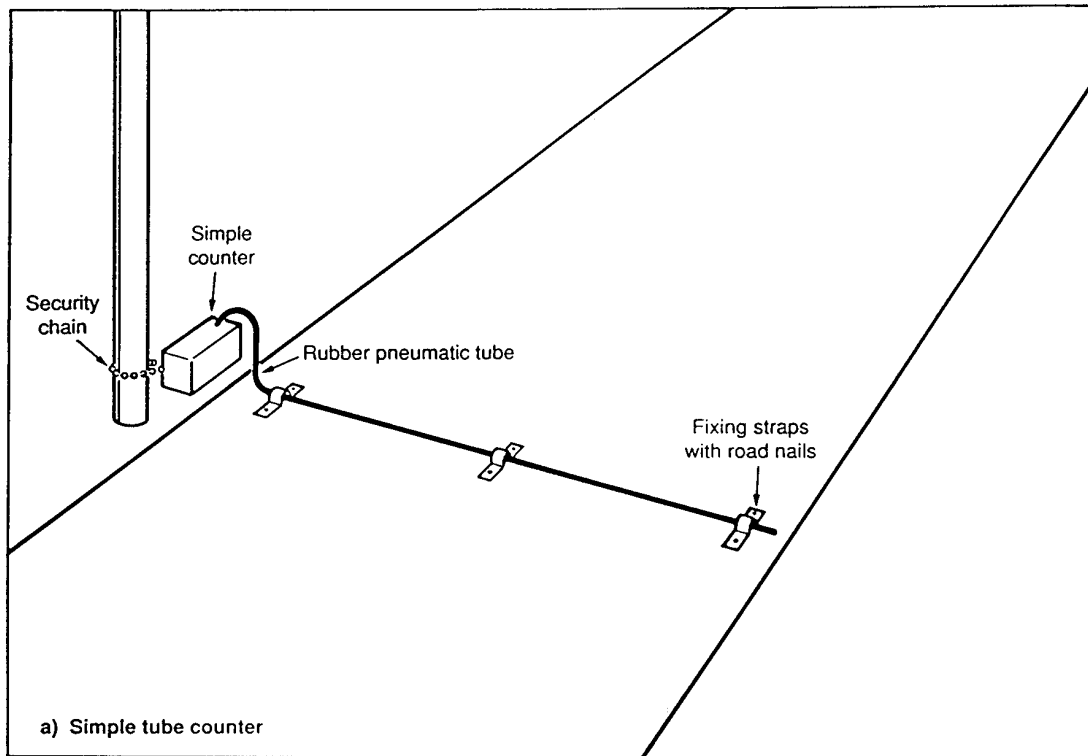

Figure 6.4 Automatic traffic counters

6.14 A loop detector detects the presence, rather than the movement of a vehicle. The counter passes an alternating electric current through the loop, creating a magnetic field above the loop. The presence of a metal vehicle in the magnetic field causes a change in the electrical inductance, which is recorded by a sensor in the counter. Non-metallic vehicles cannot be detected and pedal cycles are very difficult to detect because of their shape. Loops are usually permanent installations, laid in a shallow slot cut into the road surface, and sealed in by epoxy resin and bitumen. However, temporary loops can be fixed with sticky tape to the road surface. For loop wire specifications and installation, refer to the counter manual.

6.15 Counters are either non-storage or storage. The former accumulate a running total, which must be read manually on site but do not record data by time period. They have limited applications for measuring total volumes over a week, month, or longer. Storage counters store count data for specified time periods, for future retrieval. They are complex and expensive, but highly desirable in urban areas where hourly variations in traffic are of concern. Modern counters record data by electronic means, either on magnetic cassette tapes, or in solid-state memory. Data can be transcribed manually, but is more efficiently transcribed and summarised by computer.

6.16 A counter should be checked with at least 50 vehicles, including all major vehicle classes, over a range of speeds. This is necessary to ensure that all vehicle types which should be counted are being counted, and those not required (for example pedal cycles) are not being counted.

### **Combatting equipment errors**

6.17 Automatic traffic counters require a continuing programme of checking and maintenance, by trained technicians with access to a supply of spare parts. More sophisticated machines need more specialised maintenance without which they may prove to be of limited use. Poorly adjusted equipment gives rise to consistent over-or under-counting, while the sensitivity of the counter may deteriorate over time due, for example, to a partly blocked detector tube.

## **7 SPOT SPEED SURVEYS**

7.1 The speed of vehicles can be measured instantaneously (spot speed), or averaged over distance or time. The spot speed of a vehicle varies continuously, as the vehicle accelerates or brakes. Spot speed data is used to:

- determine observance of, and suitability of, existing speed limits.
- establish suitable new speed limits.
- determine a suitable design speed for geometric design of the highway.
- provide information for use in road safety and enforcement programmes.
- assist the location of certain traffic signs.
- determine speed-flow relationships and traffic densities (May, 1990).

Spot speed surveys can also be used to establish trends (monitoring), for example in before and after studies. Spot speeds are usually measured on links (not at junctions) and are surveyed separately for each direction, with the surveyor normally positioned on the side of the road of the direction being surveyed. Spot-speed data is collected by either a radar speed gun (which gives automatic direct measurement) or short-base methods: timing a vehicle over a known short distance, either manually with a stopwatch or automatically using modern loop or twin-tube devices.

7.2 Radar speed guns are suited to relatively narrow roads at low or medium flows, when vehicles travel past the observer individually. They are not suited to heavy traffic volumes, congestion or multi-lane roads. Furthermore, they are complex to use, require significant training of survey staff, and are expensive. Methods where vehicles are timed over a short base line are suitable for almost all traffic conditions and types of road. They require only simple and inexpensive equipment, and are less obtrusive; the main problem is overcoming parallax error. This is reduced if a high vantage point is available (Fig 7.1).

7.3 The presence of surveyors, equipment, or unusual markings on the road surface can affect driver behaviour. The need to make the surveyors inconspicuous can affect choice of survey method and location.

### **RADAR SPEED GUNS**

7.4 The location of the survey, sampling of vehicles and recording of results, are exactly the same as for the manual short base method described below. The main requirements of the radar speed gun are that the operator is fully trained on the accurate use of the equipment and that the speed gun, and its operator, are concealed from

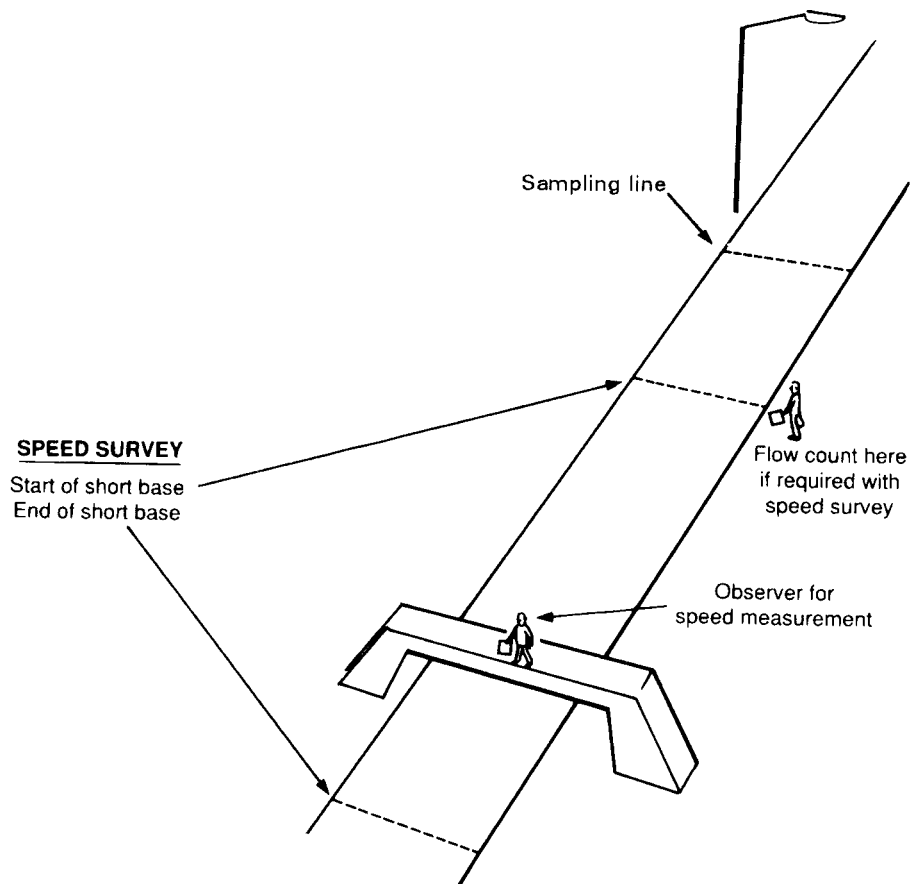

**Figure 7.1 Speed Survey using 'Short-Base' method**

drivers. Measurements can be made from inside a parked car, but the car should not be parked in any location which affects the speed of the vehicles surveyed.

## MANUAL SHORT-BASE METHOD

7.5 The survey location is usually at the middle of a road link. A specific point is chosen on the link, determined if appropriate by the study objectives (for example at a pedestrian crossing, to investigate an accident problem). A short-base length is created, over which vehicles can be timed. The length will depend on speeds on the road, with longer bases needed for higher speeds. Table 7.1 relates approximate lengths to average speeds.

**TABLE 7.1**

Short-base lengths

| Average speed of traffic (km/h) | Short-base length(m) |
|---------------------------------|----------------------|
| below 40                        | 25                   |
| 40 - 65                         | 50                   |
| above 65                        | 75                   |

Another approximate guide to length is that no vehicle in the traffic stream should take less than 2 seconds to traverse the short-base, in the traffic conditions prevailing during the survey.

7.6 The ends of the short-base length are marked on the road surface with paint, chalk, or tape lines; the lines should be as inconspicuous as possible to drivers. Alternatively, the downstream line can be defined by the surveyor standing directly opposite a roadside object (for example, a power pole or tree) on the opposite kerb. The Surveyor must always be at the downstream end. The short-base length must be measured accurately, preferably with a metal tape-measure rather than a measuring wheel. In addition a "sampling line" is marked upstream of the start line. The sampling line is needed so the surveyor can select the sample vehicle before he starts to record its travel time. The Surveyor must be able to see the sampling line and both timing lines, for all lanes of traffic; the pilot survey should determine whether a high vantage point is required.

7.7 Sample vehicles are selected at the "sampling line". The survey supervisor should define which vehicles are to be surveyed. This might be every  $n^{\text{th}}$  vehicle or according to some other method to ensure a unbiased sample (For example, as the surveyor looks up he notes the first vehicle in any lane to cross the sampling line and selects the next vehicle in any lane to cross the sampling line).

This is the "sample vehicle". The Surveyor starts the stopwatch as the sample vehicle crosses the upstream start line, and stops it as the same vehicle crosses the downstream line. The time is recorded on the survey form, together with vehicle type and whether or not it was a following vehicle in a platoon. The procedure is repeated for the next vehicle, and so on through the survey period. Both timing and recording can be completed by one surveyor using Form J.

7.8 Unlike other types of survey, spot speed surveys are usually concerned with the non-peak periods of traffic flow, when speeds are higher. For example, where free-flow speeds are needed for setting speed limits, periods of low volume and good weather are specifically chosen.

7.9 Definition of the target population is particularly important for spot-speed surveys, and may be:

- all vehicles in the traffic-stream.
- all vehicles with some choice of speed: for example vehicles at the head of a platoon or single vehicles, on a fairly busy road.
- all vehicles with a free choice of speed: this would be at low flows, when a complete choice is available.

7.10 Survey forms should allow space for a description of the chosen sampling method. It is not always necessary to include all vehicle classes; for example, cars alone are often the target population. If more than one class of vehicle is included, the class of each vehicle should be marked on the survey form.

### Output

7.11 Vehicle speeds are calculated from the times and known short-base distance. Results may be presented numerically (Table 7.2) or graphically. The most common graphical outputs are histograms (similar to Fig 5.1) and cumulative distributions of speeds which allow the extremes of the speed range to be seen.

7.12 Numerical results can be: mean speeds; the range of speeds; the proportion of vehicles above or below a certain speed (for road safety and enforcement). The 85th percentile is commonly used to describe speeds. This excludes extremely fast drivers (and gross measuring errors) and gives an estimate of what the majority of drivers consider a top limit.

**TABLE 7.2**

Example of a frequency distribution (for spot-speed data)

| Class Boundary (km/h) |       |        | Frequency |          | Cumulative Frequency |          |
|-----------------------|-------|--------|-----------|----------|----------------------|----------|
| lower                 | upper | middle | number    | relative | number               | relative |
| 27.5                  | 29.5  | 28.5   | 0         | 0.000    | 0                    | 0.000    |
| 29.5                  | 31.5  | 30.5   | 1         | 0.005    | 1                    | 0.005    |
| 31.5                  | 33.5  | 32.5   | 2         | 0.011    | 3                    | 0.016    |
| 33.5                  | 35.5  | 34.5   | 14        | 0.075    | 17                   | 0.092    |
| 35.5                  | 37.5  | 36.5   | 7         | 0.038    | 24                   | 0.129    |
| 37.5                  | 39.5  | 38.5   | 20        | 0.108    | 44                   | 0.237    |
| 39.5                  | 41.5  | 40.5   | 38        | 0.204    | 82                   | 0.441    |
| 41.5                  | 43.5  | 42.5   | 29        | 0.156    | 111                  | 0.597    |
| 43.5                  | 45.5  | 44.5   | 35        | 0.188    | 146                  | 0.785    |
| 45.5                  | 47.5  | 46.5   | 15        | 0.081    | 161                  | 0.866    |
| 47.5                  | 49.5  | 48.5   | 12        | 0.065    | 173                  | 0.930    |
| 49.5                  | 51.5  | 50.5   | 9         | 0.048    | 182                  | 0.979    |
| 51.5                  | 53.5  | 52.5   | 4         | 0.022    | 186                  | 1.000    |
| 53.5                  | 55.5  | 54.5   | 0         | 0.000    | 186                  | 1.000    |
| Total =               |       |        | 186       | 1.000    |                      |          |

## 8 NETWORK SPEEDS AND DELAY SURVEYS: THE FLOATING CAR METHOD

8.1 Average network travel times and journey speeds are a major measure of road traffic performance. Not only are they an indication of existing road link and network performance, but they help identify specific congestion spots and are important as an input to traffic models and road investment appraisals. The basic method for measuring network speed and delay (and its causes) is the Floating Car Method. Other techniques which could be adapted to achieve the same purpose are the licence plate survey (see Chapter 4) and the elevated observer method (see Chapter 9).

8.2 The advantages of the floating car technique are its direct and accurate measurement of travel times and delays, and personal experience of the causes of delays. The main disadvantages are the large resources required for a comprehensive survey of a network, and problems of the survey vehicle exceeding the speed limit. The floating car method only surveys cars. Other vehicle types can be surveyed by following a selected vehicle. However, it is difficult to choose random vehicles to follow and the route of the vehicle is not known in advance. Safety may also be a problem, especially at high speed or in heavy traffic.

8.3 For a comprehensive study of a traffic network, surveyed links should include all the main road network, and various minor roads (Fig 8.1). As a monitoring technique for 'before and after' surveys, specific turning movements should be identified for inclusion in the survey which represent 'typical' movements through the site.

### Method

8.4 The survey car is driven along a pre-determined route, at the typical speed of other cars. Surveyors in the car record the time at pre-determined timing points and the duration and cause of all stops and delays (see Fig 8.2). In addition, the distance between the timing points must be measured. If a good quality map exists (scale down to 1:2500) it can be used. Alternatively the distance must be measured on the street using a measuring wheel.

8.5 Pilot surveys should cover all survey links, at the same times of day as the full survey. This is to familiarise survey staff with the method and routes, and test the number of survey cars needed. Practice should also establish the driving style required to "float" or maintain one's position in the traffic stream, i.e. for the survey car to overtake the same number of vehicles as overtake it along the length of the route. The driver should not allow his driving style to change in response to the pressures of the survey.

### Number of runs, routes and timing points

8.6 To account for different traffic conditions throughout the day, each survey run should be related to a particular time period. Typically these periods are: morning and afternoon peaks, daytime off-peak, evening post-peak. A minimum of three runs is recommended for each time period.

8.7 Maximum route length capable of being covered in one run can be estimated from the duration of each time period being studied, the number of runs required and typical assumed speeds. For example, in a 2-hour period requiring 4 runs, the maximum route travel time would be 30 minutes; allowing (say) 10 minutes for turnaround and unexpected problems leaving 20 minutes travel time; route length at an assumed 15 km/h would be 5 km.

8.8 Route selection then depends upon covering the chosen network in the most efficient way. Survey links should be identified on a road network map of the study area, together with one-way streets and banned turns. The following points must be considered:

- most links are 2-way, and must be surveyed in both directions.
- circular routes are easier to operate; furthermore, U-turning vehicles can create problems of safety and delay, and it may be easier to have two vehicles circulating in opposite directions.
- in general, if more than one survey car is needed, it is better to use short routes with one car per route (per direction) than longer routes with more than one car per route.
- for before and after studies, the routes chosen for the before study must be repeated exactly, after the planned changes have been implemented.

8.9 Timing points should be located at every main road junction. Additional timing points should be added where there is a long distance between adjacent junctions, or where significant changes in characteristics occur (for example, road widening; a major traffic generator such as a market). There is little extra survey effort involved in adding extra timing points, and the extra information need not be processed if not required. Each timing point must be a specific, easily-identified, fixed point; a written description is required, with sketch map. At junctions, timing points will usually be the point of exit from the junction so that all delay associated with the approach to, and operation of, the junction is included with the approach link. Intermediate timing points are best located by roadside poles (for example, street light, telephone, road sign). To measure junction delay, it is best to have timing points just before a point which represents the longest queue length.

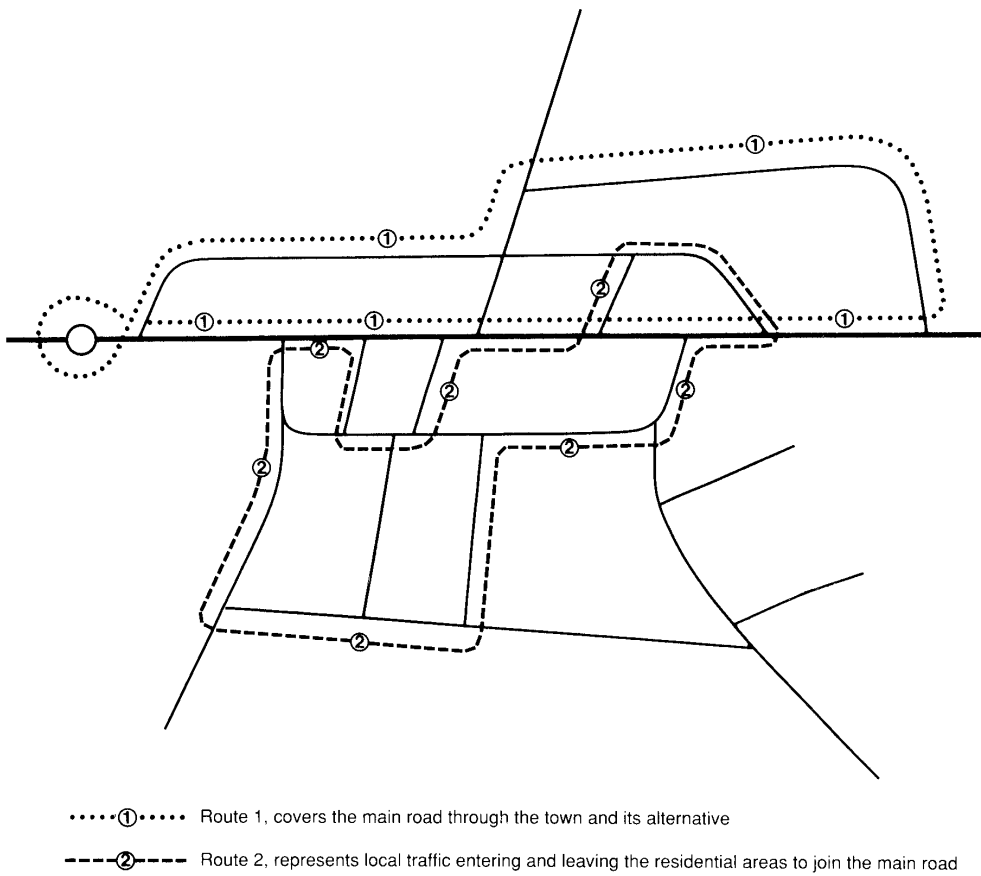

**Figure 8.1 Typical routes for moving observer/journey time surveys**

Figure 8.2 An example of a completed Journey Time/Moving Observer Delay Survey

| Overseas Unit, TRL, Crowthorne, UK |          |              |         |                   |                |                    |                          |                                |  | Form K                                                                                                                                                                                                 |  |      |
|------------------------------------|----------|--------------|---------|-------------------|----------------|--------------------|--------------------------|--------------------------------|--|--------------------------------------------------------------------------------------------------------------------------------------------------------------------------------------------------------|--|------|
| ROUTE NAME & DIRECTION             |          |              |         |                   | Route Ref. No. |                    | Surveyor(s) & Supervisor |                                |  | <small>*Indicate Start Point - SP and End Point - EP*</small><br>For sketch<br>See<br>route<br>plan<br><br>N = North<br>SP = Survey Point<br>CBD = Central<br>Business District<br><br>Sheet<br>1 of 4 |  |      |
| UTC Stage 1 - Clockwise            |          |              |         |                   | U1C            |                    | GG . JT . PF             |                                |  |                                                                                                                                                                                                        |  |      |
|                                    |          |              |         |                   |                |                    |                          |                                |  |                                                                                                                                                                                                        |  | Date |
| From                               |          | To           |         |                   |                |                    |                          |                                |  |                                                                                                                                                                                                        |  |      |
| 5.7.93                             |          | 07:00        |         | 09:00             |                | GOOD               |                          | Watch synchronised with car B. |  |                                                                                                                                                                                                        |  |      |
| Odometer                           |          |              | Vehicle |                   | Driver         |                    |                          |                                |  |                                                                                                                                                                                                        |  |      |
| Start                              | End      | Difference   |         | CAR (A)<br>TOYOTA |                | S.M                |                          |                                |  |                                                                                                                                                                                                        |  |      |
| 581.3                              | 593.7    | 12.4         |         |                   |                |                    |                          |                                |  |                                                                                                                                                                                                        |  |      |
| Location Name                      | Node No. | Time Passing |         |                   | No. of Stops   | Total Stopped Time |                          | Reasons /Notes                 |  |                                                                                                                                                                                                        |  |      |
|                                    |          | hh           | mm      | ss                |                | mm                 | ss                       |                                |  |                                                                                                                                                                                                        |  |      |
| START                              | 0        | 07           | 00      | 08                |                |                    |                          | Started at same time as car B  |  |                                                                                                                                                                                                        |  |      |
| GREEN ST                           | 1        | 07           | 02      | 17                | 1              | 00                 | 23                       | S                              |  |                                                                                                                                                                                                        |  |      |
| HIGH ST.                           | 2        | 07           | 04      | 43                | 2              | 00                 | 31                       | S, B                           |  |                                                                                                                                                                                                        |  |      |
| WEST WAY                           | 3        | 07           | 06      | 24                | 0              | —                  |                          | N                              |  |                                                                                                                                                                                                        |  |      |
| Read Rd                            | 4        | 07           | 07      | 19                | 1              | 00                 | 13                       | S                              |  |                                                                                                                                                                                                        |  |      |

## Output

8.10 Data are usually presented by link (separately by direction), either as travel time or speed, and can then be aggregated for journeys or routes. Data from individual runs should be presented individually as they represent conditions at different times of day; simple averages can be calculated, but give biased results, as more runs are made when speeds are high and delays few. If the average of runs within a period is needed for some special purpose, this can only be done by ensuring the despatcher has sent every car off (in that period) at equal intervals. To do this the despatching interval should be rather greater than the longest circuit time in the pilot survey at the most congested time. Travel times for each link or route can be compared by time of day, and may be compared with the corresponding traffic flow by time of day.

## 9 JUNCTION DELAY SURVEYS

9.1 Delay is extra *journey time* incurred when a vehicle is impeded, in excess of the journey time if not impeded. Most delays in an urban area arise at junctions or accesses. Junction delay is a measure of junction performance, usually presented in the form of average delay per vehicle. The data can be used to compare junctions and indicate those most in need of improvement (either in design or control) or to compare junction delay before and after an improvement.

9.2 There are two alternative survey techniques which are the Stopped Vehicle Count Method (counting the number of stationary queueing vehicles at fixed time intervals) and the Elevated Observer Method (timing sampled individual vehicles from a high vantage point). When comparing delay survey results (for example, in a before and after study), it is essential that the same survey method has been used.

9.3 The stopped vehicle count method:

- provides only total and average delay and cannot distinguish between delays for different turning movements.
- does not take account of delays other than on junction approaches; therefore the method is not generally suitable for junctions where a significant proportion of delay is within the junction area (for example roundabouts).
- relies on a clear determination of the number of stopped vehicles. Where the queue is "rolling" - as at roundabouts - the method is not reliable. However the method works well at traffic signals.

9.4 The elevated observer method is suitable for all kinds of junctions, where high vantage points are available, from which all approaches to the junction are visible (Fig 9.1). In addition to mean and total delay:

- distribution of delay can be calculated.
- delay can be estimated separately by turning movement.
- delays can be divided between the junction approach and the shared junction area.
- the cause of delay to each sample vehicle can be recorded (for example, junction controls, pedestrians, other stopped vehicle).

## STOPPED VEHICLE COUNT SURVEY

### Method

9.5 Using Form L the number of stopped vehicles queueing on an approach to the junction is counted at fixed intervals, usually 15 or 30 seconds, over a period of five or ten minutes. The total volume of traffic is counted at the same time.

9.6 At sites where the whole queue cannot be counted by one Surveyor, or where vehicle classification is required, the approach must be sub-divided. The distance between the stop line and a point at least 10 metres beyond the back of the longest queue is divided into a number of 'boxes' such that each box is small enough for a Surveyor to be able to maintain a continuous count of the number of stopped vehicles in it. The front wheels determine the box the vehicle is in, except that the first and last boxes should include all vehicles in front of or behind the box, respectively (Fig 9.2).

9.7 A sketch plan should be prepared, showing for every approach:

- the number of approach lanes, and any special fixed features (for example, bus stops, major accesses).
- junction controls and signs. For signalised junctions, measure cycle time based on the average values over 5 cycles, and note whether left turn on red is allowed.
- whether delay is related to traffic movements on any other approach (for example, at roundabouts, and for opposed right turn vehicles at signals).
- the longest queue normally observed during the peak period. If queues extend back to the next major junction upstream then the 'floating car method' or registration plate matching survey should be used instead.

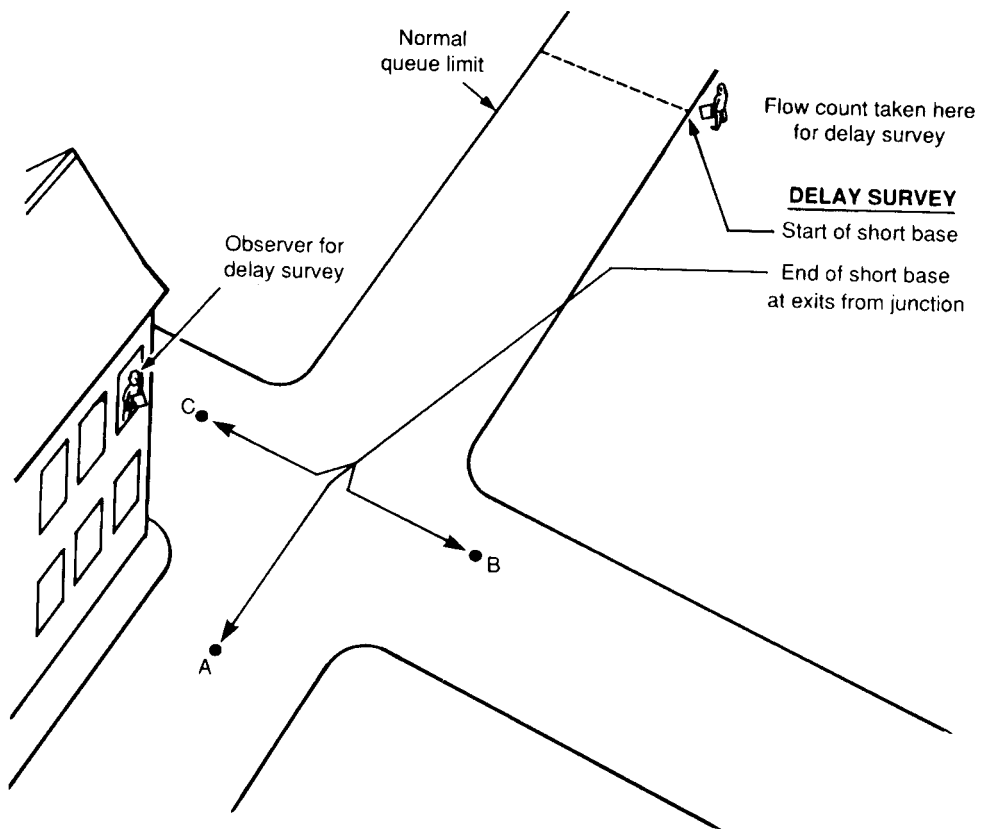
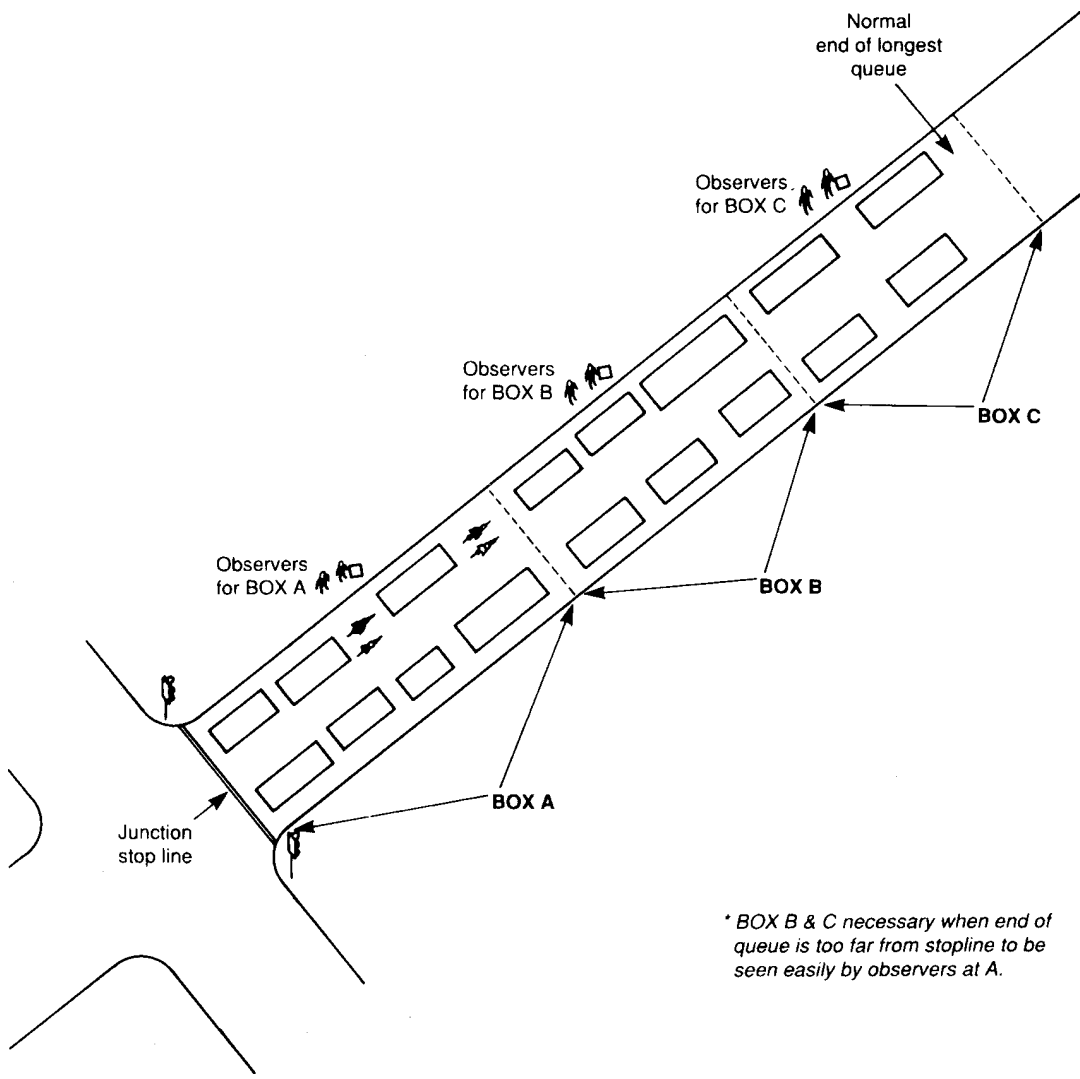

Figure 9.1 Delay Survey using 'Short-Base' method



*\* BOX B & C necessary when end of queue is too far from stopline to be seen easily by observers at A.*

**Figure 9.2 Delay Measurement by Stopped Vehicle method**

9.8 Not more than three vehicle classes per Surveyor should be used, and the same classes should be used for delay and for flow. Non-motorised vehicles are not usually included.

9.9 An observation interval of between 10 and 30 seconds should be chosen (preferably an exact factor of 60 seconds), but must not be an exact factor of any regular signal cycle time occurring during the survey. The observation interval remains fixed throughout the survey and is the same for all approaches. Duration is usually 5 or 10 minutes at a time, which allows the different approaches to a junction to be surveyed in rotation. (All approaches must be surveyed simultaneously if delays on them are related.) An example of a completed survey sheet is shown in Fig 9.3.

### Output

9.10 Total delay should be presented for each approach and for each time period studied. A grand total for all approaches may also be given provided the data were all collected at the same time. The total delay (in vehicle hours) on the approach during the duration of the survey is calculated by multiplying the total number of queueing vehicles counted in the survey period, by the fixed time interval (converted into hours). The average delay is calculated by dividing the total delay by the traffic volume in the same period.

## ELEVATED OBSERVER SURVEY

### Method

9.11 An elevated location is found from where a Surveyor can see all the approaches to the junction (Fig 9.1). Individual vehicles are timed between fixed timing points on each approach. Vehicles are identified as either "delayed" or "not-delayed" and average travel times between the timing points determined for each category. The total and average delay is derived from the difference in travel times between the two sets, noted on Form M.

9.12 For each approach three points must be identified which are visible to the Surveyor. The finish timing point can be either the exit from the junction, as defined in the travel time survey, or the stop line. The start timing point must be at least 10 metres beyond the longest anticipated queue and related to a fixed, easily identifiable object. The sampling point should be at least 20 metres in advance of the start point. A pilot survey should be used to test the procedure (which is similar in nature to the short base method for speeds-chapter 7) during the most congested time of the proposed survey period.

### Output

9.13 The calculations of delay can be made separately by vehicle class, turning movement, or time period. The average undelayed travel time is calculated from the travel times of those vehicles identified as undelayed. For the vehicles identified as delayed, their individual delay time is calculated by subtracting the average undelayed time for that class, from the sample vehicle travel time. Mean delay is estimated by calculating the mean of all the sample vehicle delays. Total delay is estimated by multiplying mean delay by the traffic volume on that approach. The values for each approach can be added to give total junction delay in the survey period.

## 10 SATURATION FLOW

10.1 The maximum sustainable flow of traffic past a point is known as the saturation flow (or sat flow). It is a fundamental characteristic of a road and an important element of traffic engineering design studies, particularly related to traffic signal control and junction design. In order to compare flows of different vehicle mix, saturation flows are usually expressed in passenger car units (PCUs) in which vehicles are given a value equivalent to the number of cars that they displace from the traffic stream.

10.2 The measurement of saturation flow, PCU values and other signal-related issues, such as lost time, is difficult. For the purpose of this manual, two alternative simplified methods for estimating sat flows at a signalised junction are outlined. These are the Flow Profile Method and the Saturated Period Count. The flow profile method consists of dividing the signal green time into regular, short, intervals (typically 6 seconds) and counting the vehicles which cross the stopline during these intervals. More details of this method, including its application to lost time measurement, are given in RRL (1963). The Saturated Period Count requires the classified counting of vehicles passing in only one interval, the duration of this interval being chosen to ensure saturation. Examples of completed survey forms for both of these methods are given in Fig 10.1.

10.3 For both methods an inventory of the junction is completed during the pilot study, using Form C, and the movements to be counted are established. If the composition of the traffic stream is stable, and especially if more than 85 per cent are cars, the saturation flow may be measured using one 'all-vehicle' category and then converted to PCUs by multiplying by the factor F, where

$$F = \frac{(N_{cars} \times 1.0 + N_{motorcycles} \times PCU_{motorcycles} + N_{others} \times PCU_{others})}{(N_{cars} + N_{motorcycles} + N_{others})}$$

Where N is the number of each type of vehicle in the traffic stream, and PCU their passenger car unit value (see below).

Figure 9.3 An example of a completed Delay by Stopped Vehicle form

| Overseas Unit, TRL, Crowthorne, UK |           |                                     |                  |                                                                           |                          | Form L |                                     |   |    |
|------------------------------------|-----------|-------------------------------------|------------------|---------------------------------------------------------------------------|--------------------------|--------|-------------------------------------|---|----|
| SITE NAME                          |           |                                     |                  | Site Ref. No.                                                             | Surveyor(s) & Supervisor |        | Sketch                              |   |    |
| SEA ROAD                           |           |                                     |                  | 1072                                                                      | GG + JT - JC             |        |                                     |   |    |
| Date                               | Time      |                                     | Weather          | NOTES                                                                     |                          |        |                                     |   |    |
| 9.7.93                             | From      | To                                  | OVERCAST         | Box (A) only<br>Newspaper vendors<br>in carriage way<br>during red period |                          |        |                                     |   |    |
|                                    | 10:25     | 11:00                               |                  |                                                                           |                          |        |                                     |   |    |
| Arm Name                           | Direction | No. of Lanes                        | Interval Time(s) | N = North                                                                 |                          | Sheet  |                                     |   |    |
| SEA RD SOUTH                       | NORTH     | 3                                   | 30               | SP = Survey Point                                                         |                          | 1 of 2 |                                     |   |    |
|                                    |           | CBD = Central Business District     |                  |                                                                           |                          |        |                                     |   |    |
| time (hh mm ss)                    |           | Number of Stopped Vehicles by Class |                  |                                                                           | time (hh mm ss)          |        | Number of Stopped Vehicles by Class |   |    |
|                                    |           | 3-                                  | 4                | 5+                                                                        |                          |        | 3-                                  | 4 | 5+ |
| 10                                 | 25        | 00                                  | 0                | 0                                                                         | 0                        |        |                                     |   |    |
|                                    |           | 30                                  | 0                | 6                                                                         | 0                        |        |                                     |   |    |
|                                    | 26        | 00                                  | 0                | 6                                                                         | 0                        |        |                                     |   |    |
|                                    |           | 30                                  | 0                | 0                                                                         | 1                        |        |                                     |   |    |
|                                    | 27        | 00                                  | 0                | 5                                                                         | 0                        |        |                                     |   |    |
|                                    |           | 30                                  | 0                | 11                                                                        | 1                        |        |                                     |   |    |
|                                    | 28        | 00                                  | 0                | 4                                                                         | 2                        |        |                                     |   |    |
|                                    |           | 30                                  | 0                | 9                                                                         | 0                        |        |                                     |   |    |
|                                    | 29        | 00                                  | 1                | 0                                                                         | 0                        |        |                                     |   |    |
|                                    |           | 30                                  | 0                | 6                                                                         | 0                        |        |                                     |   |    |

Figure 10.1 An example of completed Survey Sheets for Saturation Flow Surveys

(a) Flow Profile method

| Overseas Unit, TRL, Crowthorne, UK |      |          |          |                                                           |                          |    |     | Form N                                        |
|------------------------------------|------|----------|----------|-----------------------------------------------------------|--------------------------|----|-----|-----------------------------------------------|
| SITE NAME                          |      |          |          | Site Ref. No.                                             | Surveyor(s) & Supervisor |    |     | Sketch                                        |
| EAST ST / HIGH ST.                 |      |          |          | 0013                                                      | GG-JT-JCR                |    |     |                                               |
| Date                               | Time |          | Weather  | NOTES                                                     |                          |    |     |                                               |
| 8.7.93                             | From | To       | GOOD     | Pedestrian activity at 8am interfering with traffic flow. |                          |    |     | Sheet                                         |
| Arm Name                           |      | Movement | Lane No. | Interval (secs.)                                          |                          |    |     | 1/2                                           |
| HIGH ST (S)                        |      | N        | 1(3.2m)  | 5                                                         |                          |    |     |                                               |
| Time Intervals                     |      |          |          |                                                           |                          |    |     | Clock                                         |
|                                    | 0    | 1        | 2        | 3                                                         | 4                        | 5  | 6   | Notes/ Obstructions & Length of Last Interval |
| 1                                  | CMM  | MMC      | CC       | CM                                                        | MC                       | C  |     | 07 00                                         |
| 2                                  | MMM  | CMM      | CCM      | CT                                                        | CCM                      | CC | CC  | 07 02                                         |
| 3                                  | MM   | MMC      | CC       | MC                                                        | CMC                      | CC | C   | 7 04 Taxi problem                             |
| 4                                  | MMM  | MCM      | CMC      | MCC                                                       | CB                       | CC | CMC | 7 07                                          |
| 5                                  | MMM  | MCM      | MCC      | CC                                                        | CC                       | MC | MCC | 7 10                                          |

(b) Saturated Period Count

| Overseas Unit, TRL, Crowthorne, UK |            |                          |                     |                                                |                          |                          |  | Form P |
|------------------------------------|------------|--------------------------|---------------------|------------------------------------------------|--------------------------|--------------------------|--|--------|
| SITE NAME                          |            |                          |                     | Site Ref. No.                                  | Surveyor(s) & Supervisor |                          |  | Sketch |
| EAST ST / HIGH ST                  |            |                          |                     | 0013                                           | PF + DM - JCR            |                          |  |        |
| Date                               | Time       |                          | Weather             | NOTES                                          |                          |                          |  |        |
| 8.7.93                             | From       | To                       | ✓                   | Schoolchildren at 8am. includes initial period |                          |                          |  | Sheet  |
| Arm Name                           |            | Direction                | Lane No + Width (m) | Initial Period                                 |                          |                          |  | 1/2    |
| HIGH ST (S)                        |            | NORTH                    | 1 (3.2)             | 10secs.                                        |                          |                          |  |        |
| Cycle No.                          | Clock Time | Vehicles Passing         |                     |                                                | Time                     | Delays & Notes           |  |        |
|                                    | hh mm      |                          |                     |                                                | mm ss                    |                          |  |        |
| 1                                  | 07 00      | 4 cars . 2 M/C           |                     |                                                | 26.2                     |                          |  |        |
| 2                                  | 7 02       | 9 cars . 2 M/C . 1 Truck |                     |                                                | 31.4                     |                          |  |        |
| 3                                  | 7 05       | 8 cars . 2 M/C .         |                     |                                                | 30.6                     | Taxi stopped in junction |  |        |
| 4                                  | 7 07       | 9 cars . 3 M/C . 1 Bus   |                     |                                                | 35.5                     |                          |  |        |
| 5                                  | 7 10       | 9 cars . 3 M/C           |                     |                                                | 38.2                     |                          |  |        |

If, as is often the case in developing cities, traffic composition is very variable from cycle to cycle, and no vehicle type is dominant, then this conversion cannot be used. Groups of vehicles having a common average PCU value should be recorded in this case.

10.4 Before the surveys, the number of signal cycles to be measured must be determined. As a general guide, 25 cycles should be enough at most sites, with up to 75 being required at key junctions in the network. For very quiet or unimportant sites, it may be sufficient to estimate saturation flow using previous studies.

10.5 Measurements should ideally be made at sites which are free of all obstructions; if any obstruction occurs within a cycle, the observations for that cycle should be discarded. If the obstruction persists (as happens in many cities) and is sufficiently common as to be a true representation of the traffic pattern at that site, the observations can be kept, but analyzed separately, recording the reasons. Some typical causes of obstruction are shown in the Supervisor's log (Form A). Long term obstructions should be indicated on the inventory form, completed during the pilot survey.

10.6 The principle of the method is that the number of vehicles passing the stopline is counted at fixed short time intervals. Form N is used for recording. In addition to the points made above, the following apply specifically to the flow profile method. The length of time interval can be chosen to reflect local conditions: 6 seconds is commonly used, but if using a digital stopwatch, 5 seconds might be easier; 10 seconds may be used where queues are very long. A possible source of error arises because of the need to count (and sometimes classify) at a rapid rate. It is especially important for this survey that enumerators

are carefully chosen and given full opportunity for familiarisation with the method. In some cases, the unorthodox behaviour of traffic at signals may require revision to the survey method, for example counting during the 'red' period.

10.7 For unobstructed traffic conditions, the sat flow of each approach is simply the average flow for all saturated intervals (i.e. once the initial start-up period has been completed, and while the flow is still being supplied from a queue), as shown in Fig 10.2. This type of diagram can also help to analyse specific flow patterns, such as opposed turns. A plot of cumulative flow each cycle against time, gives a set of curves as shown in Fig 10.3. These can help to identify suspect measurements, and a representative value of sat flow (which is the gradient of these curves) can be determined by eye.

## SATURATED PERIOD COUNT

10.8 This method gives less information than the flow profile method, but is included because it is simpler to use and has been found, in practice, to give results which are not very susceptible to enumerator error (Turner, 1993). This method consists of measuring the flow of traffic, during the entire period of saturation. Providing enough enumerators are available, this method is particularly suitable for the measurement of very large flows and/or very detailed classification. To allow saturation to develop, a suitable interval should pass between the start of green and the first vehicle to be counted. A lag of four vehicles is recommended for this, but a ten second gap is often easier to measure. Form N is used for recording the data.

10.9 The saturation flow is readily calculated by dividing the flow in each green period by its duration in hours.

**TABLE 10.1**

PCU values from a review of other studies: Source Garder et al (1989)

| Vehicle Code | Vehicle Description | Min  | Max  | Suggested Value |
|--------------|---------------------|------|------|-----------------|
| 2B           | Bicycle             | 0.2  | 0.4  | 0.3             |
| 2M           | Motorcycle          | 0.2  | 0.64 | 0.4             |
| 3R           | Pedal Richshaw      | 0.93 | 1.4  | 1.2             |
| 3A           | Auto Richshaw       | 0.56 | 0.6  | 0.6             |
| 4C           | Cars and Vans       | 1    | 1    | 1               |
| 4T           | Minibus (4 tyres)   | 1    | 1.26 | 1.1             |
| 5P           | Bus (>4 tyres)      | 1.5  | 3.6  | 2.25            |
| 5G           | Goods (>4 tyres)    | 1.6  | 2.8  | 2.1             |
| L            | Horse and cart      | 2.6  | 4.0  | 3.0             |
| L            | Bullock cart        | 4.0  | 11.2 | 6.0             |
| O            | Tram                | 6    | 6    | 6               |

**Figure 10.2** A typical example of average discharge rate surveyed at a fully saturated junction  
 Using the Flow Profile method (from RRL, 1963)

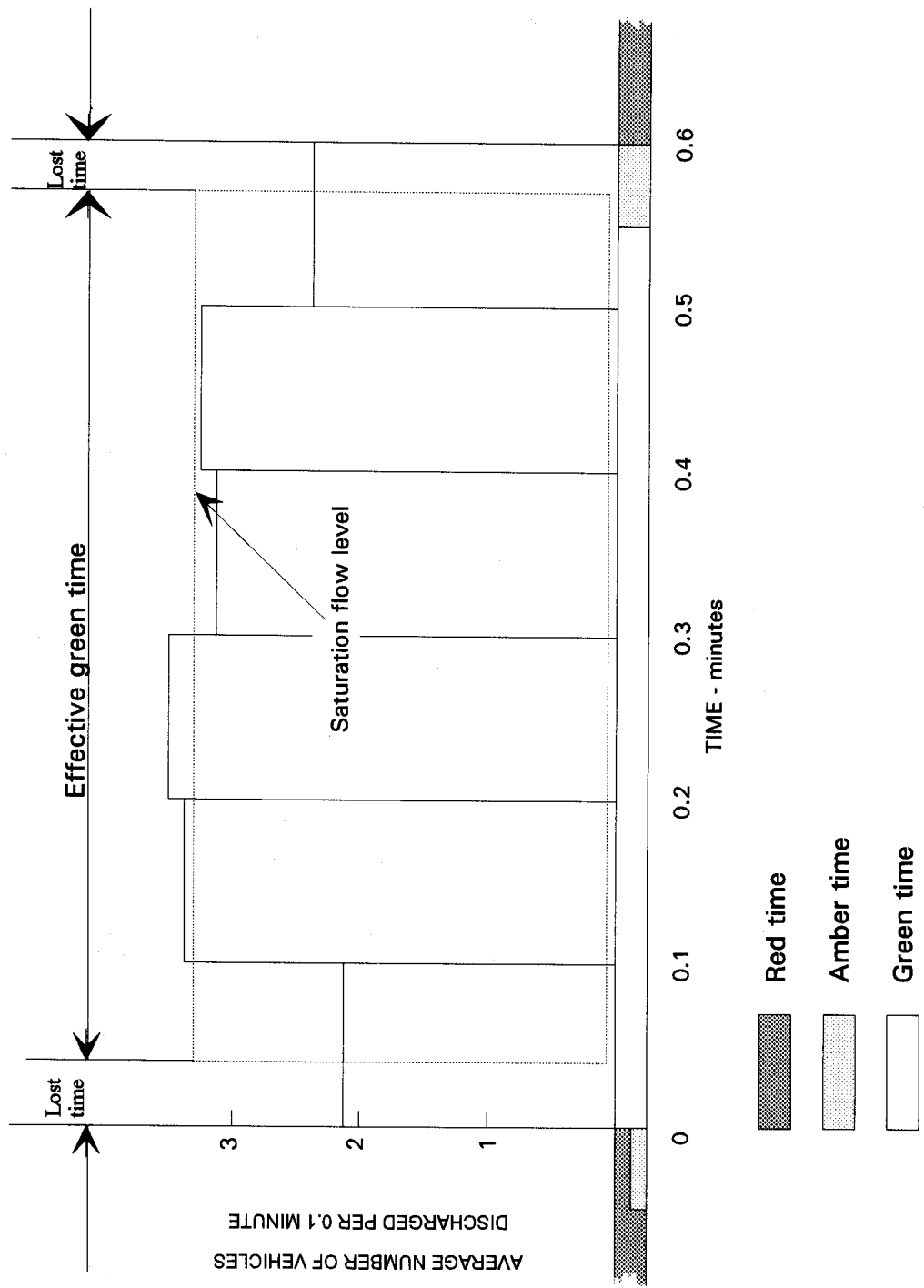
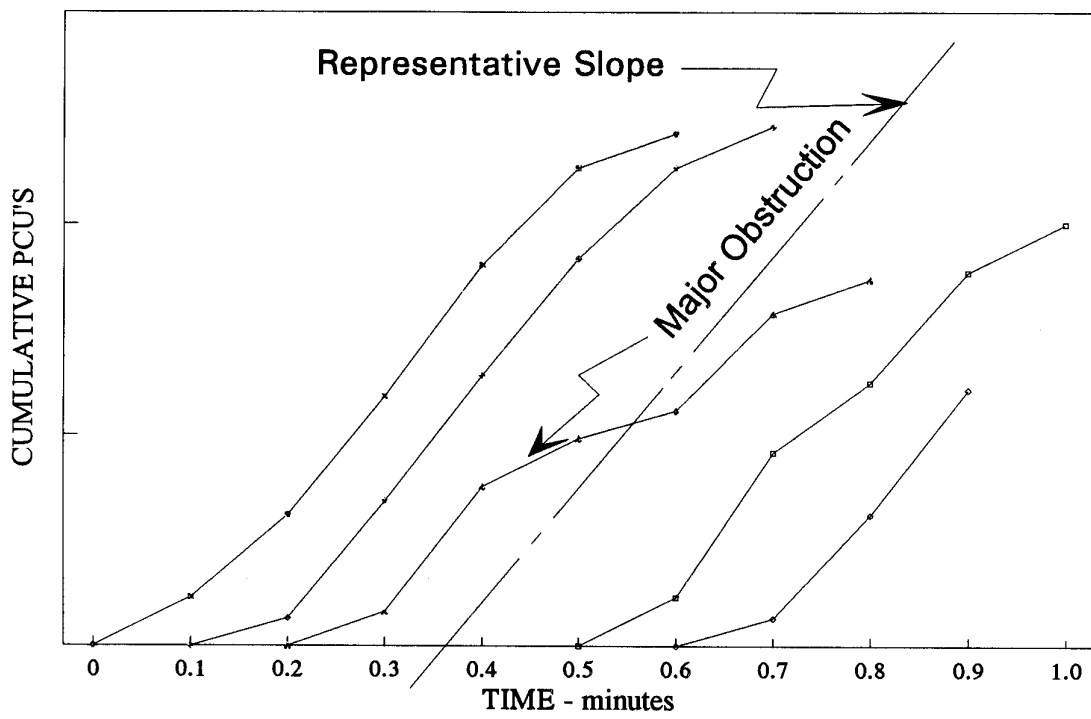

Figure 10.3 An example of a plot of Cumulative Saturation Flow



To allow for variations due to traffic conditions and enumerator error, all saturation flow measurements should be plotted as a frequency diagram (Fig 10.4) The choice of value to represent saturation flow is then a matter of judgement. For example, in Fig 10.4 the mean value would be 1800 PCUs, although it would appear that 1700 PCUs would be a more representative indicator of the current situation. For periods when interference by pedestrians is common a much lower value would be appropriate, whilst if pedestrians and buses could be controlled or segregated, then values of up to 2000 PCUs might be possible.

## PCU VALUES

10.10 If a vehicle is introduced into a stream of ordinary passenger cars and in doing so displaces the equivalent of N cars, then that vehicle can be said to have a passenger car equivalent of N passenger car units (PCUs). This is not an easy phenomenon to measure, and results can vary according to the method used. As a result, more recently the PCU value of a vehicle has come to be better defined as the ratio of its average headway, in saturated flow conditions, to that for an average car. (Headway being the time between the passage of the rear axle of the vehicle in front and the rear axle of the vehicle of interest).

10.11 However, the headway ratio method can only be used where vehicles follow each other in lanes in an orderly fashion, and is therefore not applicable in many developing countries.

10.12 Because of differences in vehicle size and types, and driver behaviour, PCU values derived in Western studies cannot be directly used in developing cities. Indeed the practice of converting all vehicles to car equivalents in some developing cities, where cars may form less than 20 per cent of the traffic, is open to question. Results from previous studies are shown in Table 10.1, the 'suggested' values given in this table could be used in the absence of any other data, but only with caution.

## 11 REFERENCES

Gardner G, Jacobs GD, and PR Fouracre 1989. Traffic Management. *TRRL Information Note*. Transport and Road Research Laboratory, Crowthorne, UK.

INSTITUTION OF HIGHWAYS AND TRANSPORTATION and THE DEPARTMENT OF TRANSPORT, 1987. Roads and Traffic in Urban Areas. HMSO.

Leonard DR & P Gower 1982. User guide to CONTRAM version 4. *Supplementary Report 735*. Transport and Road Research Laboratory, Crowthorne, UK.

May AD, 1990. Traffic Flow Fundamentals. Prentice Hall Inc., New Jersey.

ROAD RESEARCH LABORATORY, 1963. A Method for Measuring Saturation Flow at Traffic Signals. Road Research Laboratory, Crowthorne.

TRANSPORT RESEARCH BOARD, Highway Capacity Manual, *Special Report No. 208*, Washington, USA.

TRRL OVERSEAS UNIT, 1987. Field survey techniques and analysis for urban bus operation. *Overseas Road Note 4*. Transport and Road Research Laboratory, Crowthorne, UK.

TRRL OVERSEAS UNIT, 1990. Towards safer roads in developing countries. A guide for planning and engineers. Transport and Road Research Laboratory, Crowthorne, UK.

Turner J, 1993. Simplified saturation flow data collection methods. *TRL Project Report PR/OSC/003/93*. Transport and Road Research Laboratory, Crowthorne, UK.

Wells G, 1979. Traffic Engineering. An Introduction. Charles Griffin & Company Ltd., London & High Wycombe.

**Figure 10.4 Frequency Distribution Plot (Saturation Flow Survey)**

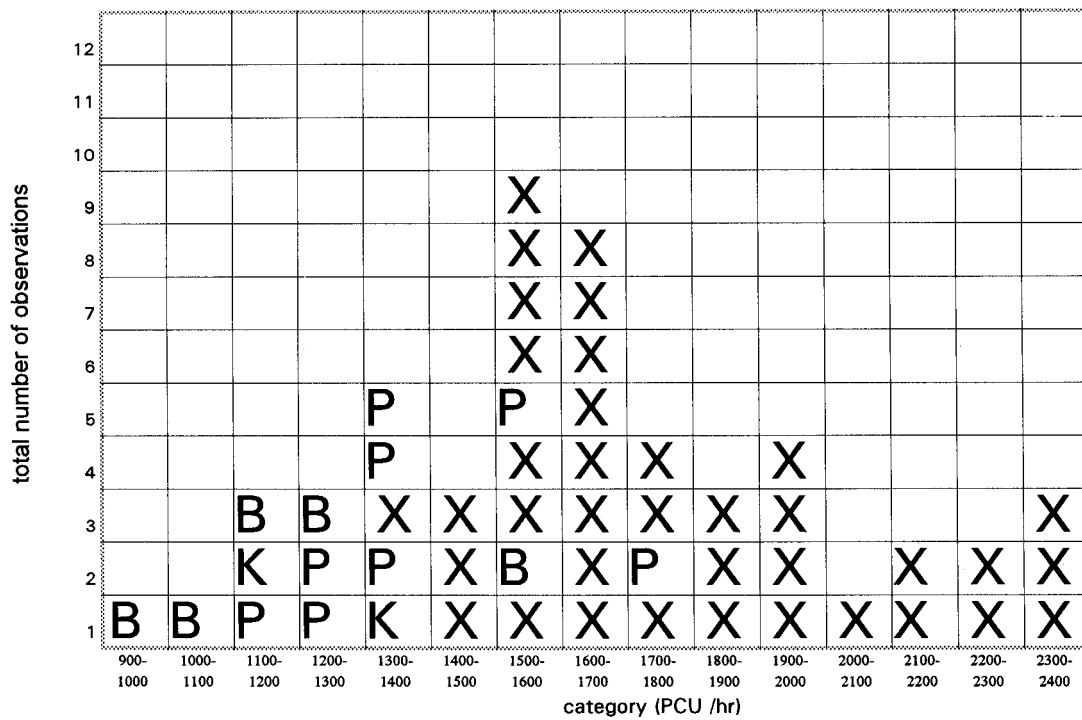

X - represents one observation (unobstructed)

P - observation affected by pedestrians

B - observation affected by bus or paratransit vehicles

K - observation affected by parking and loading

# APPENDIX A: SUMMARY STATISTICS AND SAMPLE SIZE

12.1 This appendix gives a brief outline of the techniques which traffic engineers need concerning the statistics of confidence limits and sample sizes. It begins with a description of the main statistics which are used to summarise data.

## NOTATION

12.2 The notation used in this Appendix is:

- n is the sample size
- x is any of the n values
- $\Sigma$  denotes a summation (the Greek letter "sigma")
- $\Sigma x$  ("sigma x") therefore denotes the sum of all n values of x
- $\bar{x}$  (x bar) is the arithmetic mean of all n values of x
- S is the standard deviation.

## AVERAGES AND MEASURES OF CENTRAL TENDENCY

### The arithmetic mean

12.3 The arithmetic mean is sometimes called just "the mean" or "the average". The arithmetic mean of a sample of n values

$$\bar{x} = \frac{\sum X}{n} = \frac{X_1 + X_2 + X_3 + \dots + X_n}{n}$$

### The median

12.4 The median is the arithmetic mean of the two middle values of a set of numbers arranged in order of magnitude. For symmetrical distributions the mean is equal to the median. For distributions with a right hand tail, the mean is greater; for distributions with a left hand tail, the median is greater. The value of the median is less affected by extreme values than the mean. This makes it a useful measure of central tendency in cases where there is some doubt as to whether extreme values are valid or not.

### Percentiles

12.5 If a set of data are arranged in order of magnitude, the middle value is the median. The median splits the set into two equally-sized parts. The data set can also be split in other ways. For example, the values which split the set into four equally-sized parts, each containing 25 per cent of the set, are called the 25 percentile (or more

usually "quartile") values. The values which split the set into 10 equally-sized parts are called "deciles", and the values which split the set into 100 equally sized parts are called "percentiles". Thus the median, the second quartile, the fifth decile and the fiftieth percentile are equal to each other in a given set of data. Percentiles are not widely used in all traffic analysis; but in some, particularly spot-speed studies, percentiles are calculated from the data to assist in determining speed limits. The 85<sup>th</sup> percentile (the value separating the bottom 85 per cent from the top 15 per cent of the ordered data) is widely used in this context.

## MEASURES OF THE SPREAD ("DISPERSION") OF A SET OF DATA

12.6 Most of the values in a data set may be close to the mean value (small dispersion) as in Fig 5.1, or they may be much more spread out (large dispersion) as in Fig 10.4. Thus "dispersion" means the amount the data are spread out.

### The standard deviation

12.7 The standard deviation is the most commonly used measure of dispersion. It is of interest to Traffic Engineers partly because it can describe the variation of certain items of data, e.g. speed variations, but equally because the dispersion of a data set affects confidence limits and so sample sizes.

The standard deviation ; 
$$\sqrt{\frac{\sum (\bar{x} - x)^2}{n-1}}$$

This means, in words, that each data value in turn has the mean subtracted from it and the answer is squared. These n resulting values are then added. This sum is divided by (n-1) and the square root is taken of the result, to give the standard deviation.

12.8 When the standard deviation is calculated for the whole population rather than a sample, then we use n rather than n-1 as the denominator. Calculators usually give both. It is best for traffic engineers to use n-1 (as in the above equation) in all circumstances. The standard deviation has the same units as the data from which it is calculated.

### The coefficient of variation

12.9 When it is necessary to compare dispersions, the standard deviation is often not suitable. An example might be in comparing the variation (dispersion) of travel time on two different routes. On route A, the standard deviation of travel time might be 5 minutes and on route B the standard deviation of travel time might be 10 minutes. But if the mean travel time of route B is 40 minutes, whereas that of route A, is only 20 minutes, this is not a fair comparison. In such circumstances a

measure of *relative* dispersion, the coefficient of variation, is needed.

The coefficient of variation,  $CoV = S / \bar{x}$

Thus, in the above example, if route B takes twice as long to travel on average as route A, it can be said the relative dispersion in travel times is the same on each route.

## CONFIDENCE LIMITS AND SAMPLE SIZES

12.10 When calculating a statistic (the mean or the standard deviation, for example) from a sample, the resulting value has some uncertainty associated with it because only part of the population has been measured. The sample value of the statistic is the best estimate of the true value for the population, but it is possible to calculate confidence limits about this sample value, between which the true (population) value can be expected to lie with a specified degree of certainty. To provide estimates of these confidence limits it is necessary to calculate the "standard error" of the statistic.

12.11 In all cases, if the sample has been randomly selected, there is a probability of:

- \* 68.2 per cent that the true (population) value of the statistic lies within confidence limits of plus or minus one standard error of the sample value.
- \* " 95.4 per cent that the true (population) value of the statistic lies within confidence limits of plus or minus two standard errors of the sample value.
- \* 99.7 per cent that the true (population) value of the statistic lies within confidence limits of plus or minus three standard errors of the sample value.

These probabilities are also fairly correct if the sample is not strictly random, but has been chosen with no bias.

### Standard error of the mean

12.12

$$SE_m = \frac{S}{\sqrt{n}} \quad (1)$$

Where:

$SE_m$  = standard error of the mean

S = standard deviation of the sample values

12.13 Standard error of a proportion

$$SE_p = \sqrt{\frac{P(1-P)}{n}} \quad (2)$$

Where

$SE_p$  = standard error of the proportion

P = proportion, as calculated from the sample values

This formula is appropriate if n is over about 30, but gives good estimates for smaller sample sizes.

### An example of estimating confidence limits of a sample mean

12.14 Suppose the speeds had been measured of a random sample of 100 cars. The mean speed of this sample was found to be 40km/h and its standard deviation 20km/h. To find the approximate range within which the true (population) mean speed can be expected to lie, with 95 per cent confidence, equation (1) is used to determine the standard error of the sample mean:

$$SE_m = 20/100 = 2.0\text{km/h}$$

Thus the standard error is 2.0km/h and the sample mean is 40km/h. As there is close to a 95 per cent probability that the true mean lies within a range of plus or minus two standard errors, the confidence limits are:

mean speed = 40km/h  $\pm$  4 km/h with 95 per cent confidence.

### An example of estimating confidence limits of a proportion

12.15 Suppose the proportion of vehicles exceeding a speed limit has been measured for a random sample of 100 vehicles. It was found from this sample that 0.3 (30 per cent) exceeded the limit. To find the range within which the true (population) proportion can be expected to lie, with 95 per cent confidence, equation (2) is used to determine the standard error of the sample estimate of the proportion:

$$SE_p (0.3)(0.7)/100 = 0.046$$

Thus the standard error is 0.046 (4.6 per cent) and the sample proportion is 0.3 (30 per cent). As there is approximately a 95 per cent probability that the true proportion lies within a range of plus or minus two standard errors, the confidence limits can be stated as: 'The proportion of vehicles exceeding the speed limit is 0.3  $\pm$  0.09, with 95 per cent confidence' or "The percentage of vehicles exceeding the speed limit is 30 per cent  $\pm$  9 per cent, with 95 per cent confidence".

### Using standard error formulae for estimating sample size

12.16 Equations (1) and (2) can be used to determine the required sample size (n) by rearranging them mathematically to isolate n. Thus if a mean value is needed:

$$n = \left( \frac{S}{SE_m} \right)^2 \quad (3)$$

and if a proportion is needed:

$$n = \frac{P(1-P)}{(SE_p)^2} \quad (4)$$

Equations (3) and (4) can be used to calculate n, as shown in the examples in paragraphs 12.17 and 12.18 below

**An example of estimating the sample size needed to estimate a mean value with a stated degree of accuracy.**

12.17 Suppose an estimate is needed of the mean spot speed of cars at a particular location, to an accuracy of plus or minus 10 km/h with about 68 per cent confidence. It is known from a pilot survey, that the standard deviation of car speeds is about 40 km/h. To determine the sample size of car speeds, equation (1) is used with (n) as the unknown:

$$\sqrt{n} = 40 / 10 \quad \therefore n = 16$$

The estimated minimum sample size needed is therefore 16. If the mean speed was needed to the same accuracy ( $\pm 10$  km/h) with 95 percent confidence, the 10 km/h must now equal two standard errors, so the standard error will be 5 km/h, and the calculation would be:

$$\sqrt{n} = 40/5 \quad \therefore n = 64$$

The estimated minimum sample size has risen to 64, because the range of acceptance now equals two standard errors; i.e. one standard error is 5 km/h.

**An example of estimating the sample size needed to estimate a proportion with a stated degree of accuracy**

12.18 Suppose an estimate is needed of the proportion of vehicles with a choice, which cross traffic signals when they are red, to an accuracy of  $\pm 0.1$  (10 per cent) with 95 per cent confidence. Previous studies have suggested the proportion is likely to be about 0.4 (40 per cent) (Note: if there is no prior information on the proportion, it is best to assume 0.5). To determine the required sample size, equation (2) is used; confidence limits at close to the 95 per cent level are set by plus or minus two standard errors and this means that 0.1 must equal 2 standard errors, so one standard error equals 0.05.

$$n = (0.4)(1-0.4)/(0.05)^2 = 96$$

The estimated minimum sample size is 96 randomly selected vehicles.

## APPENDIX B: GENERAL CHECKLIST FOR SURVEY SUPERVISORS

13.1 The Survey Supervisor plays a key role in the organisation and performance of any traffic survey. There are tasks which are common to all types of survey, which can be set out as follows:

13.2 Before the survey:

- establish survey station layout, and any necessary network reference numbers
- divide study area into survey areas as appropriate
- determine required number of Surveyors.
- arrange transport, pick-up times and locations, with adequate travel time to the site.
- ensure adequate supplies of materials and equipment.
- organise vehicles and drivers for use in mobile surveys.
- organise, where appropriate, route maps with all road names clearly marked showing survey route and any
- supervise picking up of Surveyors and travel to site.
- at the site, deploy Surveyors (duties and locations).
- hand out materials and equipment.
- synchronise watches, and synchronise the start of the survey, possibly using a whistle or alarm clock.

13.3 During the survey:

- check timekeeping.
- check accuracy of observations by Surveyors.
- synchronise time period changes, possibly using a whistle or alarm clock.
- collect completed survey forms, making certain that headers have been correctly filled out.
- ensure an adequate supply of blank forms and stationery

13.4 At the end of the survey the Supervisor should ensure that all survey forms are collected and are properly labelled. Data checking and correction should take place as soon as possible after the survey, by the same team of Surveyors used for the survey itself.

13.5 The Supervisor should keep a record of the survey work using Form A as a log.

## APPENDIX C: INSTRUCTIONS FOR SURVEYORS

### LINK INVENTORY

14.1 Form B is used for recording link inventory data. The procedures to be adopted during the survey are as follows:

- Record field data sheet heading details; in particular orientate the field sheet by recording the street name, and junctions with other streets.
- Commence walking or driving along the link. Measure the chainage by pacing, vehicle odometer, or measuring wheel.

The information to be recorded will be specified by the Supervisor, but will include:

- Cross-section dimensions (road, footpath/hard shoulder, any height or width restrictions, right of way)
- Traffic management controls (1-way streets, banned turns, pedestrian facilities, bus, taxi and service vehicle bays)
- Street furniture (road signs and markings including lane widths, speed restrictions and details of parking controls, street lights, bus stops, crash and pedestrian barriers )
- Service vehicle and private accesses
- Frontage land use (residential, educational, shop, commercial, etc.)
- Road side activities which take up footpath or road space (area and type of activity.)
- Crossfall or superelevation
- Vertical curvature, gradients and horizontal curvature
- Pavement construction type and surface condition.

14.2 Some of this information may be classified into a simple rating scale, which the supervisor will explain prior to the survey. For example, a five point scale for surface condition might be:

- 1- vehicles forced to slow and drive around potholes.
- 2- some rough patches, poor wet weather grip
- 3- some worn patches without significant effect on traffic.
- 4- good surface
- 5- perfect flat surface with good wet weather grip.

Horizontal curvature may be graded as: low (up to 30 deg.); medium (30 to 90 deg.); high (more than 90 deg). Gradients and vertical curvature may be similarly grouped.

14.3 Activities on the footpath or in the carriageway (for example street vendors, food stalls) can reduce the **effective** road width. Surveyors must measure the nominal road width and also record the area occupied by these other activities. This should be done even if the activity occurs only at certain times of day.

### JUNCTION INVENTORY

14.4 Form C is used. The Surveyor should record the sheet heading details; in particular he should orientate the field sheet by sketching the junction and showing all the street names and a north point arrow. Information is measured and recorded for each approach road as for the link survey, but special note should also be made of:

- junction type (uncontrolled/priority/signals/roundabout)
- signal characteristics (timing if fixed, phasing, controller type)
- width of approach
- kerb entry and exit radii (calculated from the target distance and deflection angle assuming they are circular curves)
- number of lanes, and lane widths.
- visibility splays

14.5 Traffic signal equipment and settings require special attention and it is recommended that Surveyors with some knowledge of signal operations are used to undertake this work.

### PARKING INVENTORY

14.6 Each surveyor is allocated a route through the survey area which covers all possible parking locations. As he walks the route he records on a map of the route all locations where parking is restricted or banned. For all other locations he estimates the parking capacity and records these also. Where parking spaces are marked out, the spaces can be simply summed. Where no formal markings exist estimates can be based on the following:

- kerbside parking spaces of 6.0 x 2.5 metres, excluding accesses and bus stops, etc.
- for informal areas, particularly off-street, allow 25-30 square metres per car. This allows space for circulation and access/egress.

## PARKING PATROL SURVEYS

14.7 The Surveyor should familiarise himself with the survey start point, the frequency of patrol and the route. The route is divided into sections and a new copy of Form D is used for each section. After filling in the survey form headings, the patrol is started at the exact start time. For each vehicle occupying a parking space, the following is recorded:

- the full registration number
- vehicle type

For formally marked spaces which are empty, the box on the survey form can be left blank. However, for informal (unmarked) spaces this may not be practical; in this case the registration numbers of parked vehicles should be simply listed on the form, without blanks.

14.8 The Surveyor should patrol at approximately the same walk speed even when not busy recording data. It is not desirable for the Surveyor to hurry round in periods of low demand, causing a long wait before departing on his next circuit at the appointed time. At the end of the patrol, the Surveyor waits until the scheduled start time of his next patrol.

14.9 Vehicles entering parking spaces should be recorded, but not vehicles leaving parking spaces. Vehicles not clearly in a space should be treated consistently; for example, using the position of the front wheels to indicate which space is in use. Special problems may arise with some vehicle types:

-large numbers of motorcycles may be parked at a particular spot and recording all registrations would be extremely time-consuming.

- bicycles may cause a similar problem, but they do not usually have registration numbers
- public transport or freight vehicles (for example bicycle rickshaws, motorcycle taxis, minibuses, pick-ups) waiting for custom may also take up parking space, and create problems.

In the case of the first two examples, only the total number of each vehicle type within the area need be recorded. Public transport and freight vehicles can either be ignored or recorded, depending on the survey objectives.

## REGISTRATION NUMBER SURVEY

14.10 This survey uses Form F. Before starting the survey, the Supervisor will confirm the sampling method to be used. After filling out the header information each surveyor scans the front registration plates of all vehicles coming towards him in one direction. When a vehicle is seen bearing a registration number ending in one of the sample numbers, the following information is entered:

- the full registration number
- exact time of crossing the survey line (if journey times are also required, otherwise only approximate time is required).
- vehicle type.

14.11 If traffic is bunched, only the registration number should be recorded, to minimise the chances of missing vehicles in the chosen subset. The time can be estimated later by interpolation, provided a time is recorded for the first and last vehicle in a bunch.

14.12 Surveyors should be located where all registration numbers in all traffic lanes can be seen. Footbridges or other raised points can be advantageous, depending on their height, and the size and legibility of registration plate characters. Surveyors should not be located:

- just downstream from signals, as traffic will be bunched.
- just upstream from signals, as travel times will be distorted by junction delays.

14.13 It is important that none of the vehicles in the subset are missed. Surveyors who know they have missed or incorrectly recorded vehicles should be encouraged to say so; this enables the problem to be corrected in future surveys. Methods of correction may include:

- using a separate Surveyor for each sample digit.
- using a separate Surveyor for each vehicle class.
- having one Surveyor looking and shouting, and one recording, so traffic flow is continually scanned.

If the Surveyor has any doubts about the data he is recording, he should put a question mark in brackets.

## MANUAL TRAFFIC COUNTS

14.14 Form G is used in this survey. Surveyors should adopt the following procedures:

- Identify a suitable marker (for example a telephone pole or road sign) on the other side of the road which he can stand or sit directly opposite
- Record each vehicle that crosses an imaginary line between himself and the marker, when it crosses the line (not before or after), either directly on the survey form (in the correct box), or on a tally.
- At the start of the survey (usually on the hour) commence a new survey form, and fill in the headings.
- At the end of each count period commence a new form, and file the completed form.

14.15 Hand tallies and stopwatches should never be reset to zero at the end of a count period, because it is a common error to forget to write the total down, thus losing the data. Cumulative values should be recorded on Form H.

14.16 Surveyors must *never* 'invent' data, particularly at the busiest times. If mistakes or omissions are made, they should be noted and described.

## SPOT SPEED SURVEY

14.17 The supervisor must identify the short-base reference points; these are the sampling line, the timing start line, and the finish line. The vehicle types to be surveyed must also be identified. Form J is used for recording data. After filling out the headings on the survey form, the stopwatch should be zeroed and any vehicle which meets the selection criteria identified at the sample line (see paragraph 7.7); the stopwatch is started as the vehicle crosses the start line, and stopped as it crosses the stop line. The time is recorded, and the procedure repeated.

## FLOATING CAR SURVEY

14.18 Form K is used in this survey. Each survey car contains three persons: two Surveyors and the driver. Their roles are as follows:

### Surveyor 1:

- controls the survey. In particular the driver must obey instructions concerning speed and manoeuvres.
- must ensure that he is familiar with the route and the timing points.
- determines when everyone is ready.
- instructs the driver to start. The car must enter the traffic stream before the start of the timed route.
- calls each timing point (in the manner: "timing point 7 .... NOW").
- marks each timing point, by calling the moment of passing.
- times the delay if the car is stopped, and calls out *duration* (in seconds) and cause to be recorded by **Surveyor 2**.
- ends the run after the vehicle passes the last timing point.

### Surveyor 2:

- records all the field data, and controls all the equipment except the stopwatch (and the vehicle).

- ensures that the route inventory, chronometer, field forms, and stationery are prepared, and that the header information on each form is filled in.
- at the word "NOW", records the chronometer time precisely on the field survey form (to the nearest second, using the 24 hour clock) against the appropriate timing point.
- records durations of, and reasons for, delays called out by **Surveyor 1**. A separate line is used for every delay.

### Driver:

- learns the route
- drives normally, basically "floating" in the traffic flow, trying to overtake as many vehicles as overtake him (cars turning off the route should be ignored), but driving safely.
- obeys instructions from Surveyor 1.

14.19 If more than one car is used on a route, the cars should be spaced out. Timing points must be defined exactly. For example, if a power pole is a timing point, the time is called as the car crosses an imaginary line drawn from the pole, at right angles across the road. The exact time of passing the timing point can be related to the front of the car, the rear of the car or the surveyor. This must remain the same throughout a survey run.

14.20 Delay time is simply defined as any time lost when the vehicle is slowed down below the typical running speed of vehicles on that street. However such judgements require experienced surveyors. With less experienced surveyors, more precise definitions may be required; for example, if the vehicle is travelling at less than walking speed or stopped time is when the tyre treads of the vehicle in front can be seen. Sometimes it is not possible to see the cause of delay, and this should be noted as "unclear".

## JUNCTION DELAY: STOPPED VEHICLE COUNT METHOD

14.21 Three surveyors are required for each junction arm and Form L is used for data recording. The role of each person is:

### Surveyor 1:

- keeps a count of the number of *stopped vehicles*, by vehicle class. This is best done aloud, e.g. "7,6,1" could be seven motorcycles, six light vehicles and one heavy vehicle. Vehicles moving, however slowly, are not included in this count.

### Surveyor 2:

- controls the timing by calling out the start, and then the timing intervals with a 10-second warning and a

five-second countdown ("10 seconds to go, 5-4-3-2-1-NOW").

- records the vehicle count called out by Surveyor 1 at each "NOW" point.
- fills in the survey form headings.

#### **Surveyor 3:**

- counts all vehicles, from the start to end of the survey, by vehicle class if required.
- separates these into "stopping" and "non-stopping" if possible.

14.22 Any vehicle which stops for reasons other than queuing must not be counted (for example, buses or taxis picking up passengers, parked vehicles). Also, other vehicles impeded by these vehicles must not be included.

14.23 Defining the number of queuing vehicles can be uncertain. It can be the number of stationary vehicles, or it can include, in addition, vehicles still moving but nevertheless delayed. The difficulty lies in defining the speed up to which a vehicle can travel while 'queuing'. In general, only stopped vehicles are counted, although this results in total delay being underestimated. However, this is generally not important as delay measurements are usually used for comparison.

14.24 The number of stopped vehicles can change very quickly. For example, there may be many stopped vehicles just before the instant of recording, but at the exact instant all may have started to move slowly. The correct number to record is those vehicles stopped at the exact *instant* of recording. Surveyors, having seen the stopped vehicles, tend to record that number, even if the vehicles have all just started moving; the Supervisor must ensure that this does not happen. There are likely to be many zero observations of stopped vehicles.

## **JUNCTION DELAY SURVEY: ELEVATED OBSERVER METHOD**

14.25 Observations are recorded on Form M. The Surveyor selects a sample vehicle at the sampling line taking care to ensure that the selection of vehicles is done without bias, as described in paragraph 7.7; No element of personal choice should enter the sampling procedure. This procedure is repeated for the next sample vehicle and so on for the period of the survey. The vehicle is timed from the upstream timing point to the downstream timing point, using a stopwatch. The information he records is:

- vehicle type.
- stopwatch time.
- whether the vehicle was delayed.
- time of day.

## **FLOW PROFILE COUNT**

14.26 Form N is used for data recording. Junction turning counts, if required separately, are collected using a variant of Form G. The survey involves three Surveyors whose tasks are as follows:

#### **Surveyor 1:**

- starts his watch when the green light appears and shouts 'GO'
- identifies the last queuing vehicle when the lights turned green.
- shouts "one" at end of first interval, "two" at the end of the second interval etc.
- shouts "last" if the last queuing vehicle passes during the green period, otherwise...
- shouts "stop" when green light disappears and stops watch.

#### **Surveyor 2:**

- as the rear wheels of each vehicle passes over the stopline he shouts the initial letter for the appropriate category.
- if measuring saturation flow only, he stops counting when Surveyor 1 shouts "last" or "finish"
- if measuring a complete flow profile, or a full count of all vehicles, he keeps shouting for every vehicle passing.

#### **Surveyor 3:**

- writes down the initials of each vehicle as it is shouted out by the Surveyor 2.
- when Surveyor 1 shouts 'one, two' etc., he starts recording in the next column on the survey form.
- When Surveyor 2 shouts 'last' stops recording.
- (If required for lost time calculations; when Surveyor 2 shouts last, he writes an elongated 'L' in the appropriate column and when Surveyor 1 shouts 'stop' he writes an elongated 'S' in the appropriate column. See RRL, 1963 for more details)
- records anything which might have affected the measurement in the notes column.
- if vehicles pass during more than the 8 intervals allowed for on the survey form, go on to the next line, making sure to include a 'C' for 'continuation' in column.

## SATURATED PERIOD COUNT

14.27 Form P is used to record data. Junction turning counts, if required separately, are collected using Form G. The survey involves a minimum of two Surveyors and probably more. The two most numerous categories of vehicle are assigned to the initial two Surveyors; whether the remaining categories can be counted by one person, or whether more staff are required, must be judged by the Supervisor. He must also collect any special information required. In particular, the presence of parking or other activities in the kerbside lane for 100 metres upstream and 50 metres downstream of the junction should be noted for each cycle in the appropriate column. Note should be made of any event which has any influence whatsoever on traffic flow during each cycle in the 'notes' column on the survey sheet.

14.28 The tasks of the Surveyors are as follows:

### Surveyor 1:

- starts the stopwatch when the green light appears.
- looks to the back of the queue and identifies the last vehicle to join the queue when the lights changed. This is known as the 'last queuing vehicle'.
- shouts 'now' when the stopwatch shows ten seconds.
- shouts 'stop' when the last queuing vehicle passes the stopline (or when the green light disappears), and stops the stopwatch.
- records in the appropriate place on the form, the clock time (column 1), the elapsed time (col 6) and the number of vehicles in each category (col 7).
- makes a note of any event which may have affected traffic flow during the cycle or the timing of it, or of any comments made by any of the counters (col 7).

### Surveyor 2:

- counts all vehicles of type C (or as instructed by the Supervisor) as their rear wheels pass over the stopline, from when Surveyor 1 shouts 'now' until he shouts 'stop'.
- gives the number of vehicles counted to Surveyor 1.
- informs the Surveyor 1 of anything which affects the traffic flow being measured.
- if Surveyor 2 loses count, he should stop counting and tell the Surveyor 1. There must be no guessing.

If other Surveyors are being used they will do the same as Surveyor 2, but count other vehicle types.

| SUPERVISOR'S LOG                                              |      |                   |          |               |                                     |                                           |                           |                                          |  |
|---------------------------------------------------------------|------|-------------------|----------|---------------|-------------------------------------|-------------------------------------------|---------------------------|------------------------------------------|--|
| Overseas Unit, TRL, Crowthorne, UK                            |      |                   |          |               |                                     |                                           |                           | Form A                                   |  |
| SITE NAME                                                     |      |                   |          | Site Ref. No. |                                     | Surveyor(s) & Supervisor                  |                           | Location Plan                            |  |
| Date                                                          | Time |                   | Weather  | NOTES         |                                     |                                           |                           |                                          |  |
|                                                               | From | To                |          |               |                                     |                                           |                           |                                          |  |
| Survey Reason                                                 |      |                   |          | Requested By  |                                     |                                           |                           | Sheet                                    |  |
|                                                               |      |                   |          |               |                                     |                                           |                           | /of                                      |  |
| SKETCH OF SITE                                                |      |                   |          |               |                                     |                                           |                           |                                          |  |
| N = North, CBD = Central Business District, SP = Survey Point |      |                   |          |               |                                     |                                           |                           |                                          |  |
| DETAILS OF TEAM:                                              |      |                   |          |               |                                     |                                           |                           |                                          |  |
| Initials                                                      | Name | Duty              | Start    | End           | Form Type                           | Equipment Given                           | Equipment Returned        | Notes                                    |  |
|                                                               |      |                   |          |               |                                     |                                           |                           |                                          |  |
| DIARY OF EVENTS:                                              |      |                   |          |               |                                     |                                           |                           |                                          |  |
| Date, Time                                                    |      |                   | Incident |               |                                     | Action Taken                              |                           | Influence on Results (low, medium, high) |  |
|                                                               |      |                   |          |               |                                     |                                           |                           |                                          |  |
| Vehicle Categories Used                                       |      |                   |          |               | Delay Codes Used (delete or circle) |                                           |                           |                                          |  |
| Group                                                         | Code | Description       | Group    | Code          | Description                         | Reasons for Delay (with codes where used) |                           |                                          |  |
| 3-                                                            | 2B   | Bicycle           | 5+       | 5P            | Bus (> 5 tyres)                     | S = Signals                               | Roadworks - Diversion     |                                          |  |
|                                                               | 2M   | Motorcycle        |          | 5G            | Goods (> 5 tyres)                   | J = Other Junction                        | Accident - Breakdown      |                                          |  |
|                                                               | 3R   | Pedal Rickshaw    |          |               |                                     | P = Pedestrians                           | Floods - Weather Extremes |                                          |  |
|                                                               | 3A   | Auto Rickshaw     |          | L             | Leg-powered                         | B = Bus or Paratransit                    | Encroachments             |                                          |  |
| 4                                                             | 4C   | Cars-Vans         |          | O             | Other                               | K = Parked or Loading                     | Police Intervention       |                                          |  |
|                                                               | 4T   | Small Paratransit |          |               |                                     | N = Not Delayed                           | Unknown - Other           |                                          |  |

| <b>LINK INVENTORY</b>                                                                                                                                                                                                                 |  |      |               |               |               |                          |             |        |                     |  |
|---------------------------------------------------------------------------------------------------------------------------------------------------------------------------------------------------------------------------------------|--|------|---------------|---------------|---------------|--------------------------|-------------|--------|---------------------|--|
| Overseas Unit, TRL, Crowthorne, UK                                                                                                                                                                                                    |  |      |               |               |               |                          | Form B      |        |                     |  |
| SITE NAME                                                                                                                                                                                                                             |  |      |               | Site Ref. No. |               | Surveyor(s) & Supervisor |             | Sketch |                     |  |
| Date                                                                                                                                                                                                                                  |  | Time |               | Weather       |               | NOTES                    |             |        |                     |  |
|                                                                                                                                                                                                                                       |  | from | to            |               |               |                          |             |        |                     |  |
| TYPE OF ROAD                                                                                                                                                                                                                          |  |      |               |               |               |                          |             | Sheet  |                     |  |
|                                                                                                                                                                                                                                       |  |      |               |               |               |                          |             | /of    |                     |  |
| DIRECTION OF                                                                                                                                                                                                                          |  |      | TYPE OF JUNC. |               | LENGTH        |                          | JUNCT. WITH |        | NODE NO.            |  |
|                                                                                                                                                                                                                                       |  |      |               |               | Odom. Measure |                          |             |        |                     |  |
|                                                                                                                                                                                                                                       |  |      |               |               | k             |                          |             |        |                     |  |
| A                                                                                                                                                                                                                                     |  |      | B             |               | C             |                          | D           |        |                     |  |
| NO. OF SIDE STREETS                                                                                                                                                                                                                   |  | H    | M             | L             | FOOTWAY       |                          |             |        | NO. OF SIDE STREETS |  |
|                                                                                                                                                                                                                                       |  |      |               |               | Paved Width   |                          | Paved Width |        |                     |  |
|                                                                                                                                                                                                                                       |  |      |               |               |               |                          |             |        |                     |  |
|                                                                                                                                                                                                                                       |  |      |               |               | 1/4           |                          | 1/4         |        |                     |  |
|                                                                                                                                                                                                                                       |  |      |               |               | 1/2           |                          | 1/2         |        |                     |  |
|                                                                                                                                                                                                                                       |  |      |               |               | 3/4           |                          | 3/4         |        |                     |  |
|                                                                                                                                                                                                                                       |  |      |               |               | B             |                          | D           |        |                     |  |
| DIRECTION OF                                                                                                                                                                                                                          |  |      | TYPE OF JUNC. |               | SLOPE         |                          | BENDS       |        | JUNCT. WITH         |  |
|                                                                                                                                                                                                                                       |  |      |               |               | H M L         |                          | H M L       |        |                     |  |
|                                                                                                                                                                                                                                       |  |      |               |               |               |                          |             |        |                     |  |
|                                                                                                                                                                                                                                       |  |      |               |               |               |                          |             |        |                     |  |
| <b>CHECKLIST</b>                                                                                                                                                                                                                      |  |      |               |               |               |                          |             |        |                     |  |
| Pedestrian facilities - islands, bridges, etc.<br>Public Transport - stops (including informal)<br>Street lights - height and colour of bulb<br>Encroachments - permanent or temporary<br>Road surface - potholes, ponds, white lines |  |      |               |               |               |                          |             |        |                     |  |

| <b>JUNCTION INVENTORY</b>          |  |               |                          |         |
|------------------------------------|--|---------------|--------------------------|---------|
| Overseas Unit, TRL, Crowthorne, UK |  |               |                          | Form C  |
| SITE NAME                          |  | Site Ref. No. | Surveyor(s) & Supervisor |         |
| Date                               |  | Time          |                          | Weather |
|                                    |  | From          | To                       |         |
| NOTES                              |  |               |                          |         |
| Junction Type                      |  | Cycle Time    | Controller Type          |         |
|                                    |  |               |                          | Sheet   |
|                                    |  |               |                          | /of     |

**Link No.** ↑

← (effective width) →

|          |   |
|----------|---|
| turn ban | ↓ |
| one way  | ↓ |
| 2        | ↓ |

Name: \_\_\_\_\_

Green Time (secs.) \_\_\_\_\_

median (m) ←    → (m)

lanes: \_\_\_\_\_

lanes: \_\_\_\_\_

median (m) ←    → (m)

Green Time (secs.) \_\_\_\_\_

Name: \_\_\_\_\_

|          |   |
|----------|---|
| one way  | ↑ |
| turn ban | ↑ |
| 2        | ↑ |

← (effective width) →

Direction of ↓    Link No. \_\_\_\_\_

lanes: \_\_\_\_\_

median (m) ←    → (m)

Green Time (secs.) \_\_\_\_\_

Name: \_\_\_\_\_

|          |   |
|----------|---|
| one way  | ↑ |
| turn ban | ↑ |
| 2        | ↑ |

← (effective width) →

Direction of ↓    Link No. \_\_\_\_\_

lanes: \_\_\_\_\_

median (m) ←    → (m)

Green Time (secs.) \_\_\_\_\_

Name: \_\_\_\_\_

|          |   |
|----------|---|
| one way  | ↑ |
| turn ban | ↑ |
| 2        | ↑ |

← (effective width) →

Direction of ↓    Link No. \_\_\_\_\_

**X CHECKLIST:**

- Pedestrian Facilities - islands, bridges, etc.
- Public Transport - stops (including informal)
- Street lights - height and colour of bulb
- Encroachments - permanent or temporary

**Y SIGNALS EQUIPMENT:**

- 3 aspect primary signal
- 3 aspect secondary signal
- filter arrow
- pedestrian signal
- signal mast assembly
- signal controller box

| <b>PARKING BEAT SURVEY</b>                                                |             |                    |              |               |                    |                          |  |                                                                                    |  |        |        |     |
|---------------------------------------------------------------------------|-------------|--------------------|--------------|---------------|--------------------|--------------------------|--|------------------------------------------------------------------------------------|--|--------|--------|-----|
| Overseas Unit, TRL, Crowthorne, UK                                        |             |                    |              |               |                    |                          |  |                                                                                    |  |        | Form D |     |
| SITE NAME                                                                 |             |                    |              | Site Ref. No. |                    | Surveyor(s) & Supervisor |  |                                                                                    |  | Sketch |        |     |
| Date                                                                      |             | Time               |              | Weather       |                    | NOTES                    |  |                                                                                    |  |        |        |     |
|                                                                           |             | From               | To           |               |                    |                          |  |                                                                                    |  |        |        |     |
| ROUTE NAME                                                                |             |                    |              | DIRECTION     |                    |                          |  | <small>N = North<br/>SP = Survey Point<br/>CBD = Central Business District</small> |  |        | Sheet  |     |
|                                                                           |             |                    |              |               |                    |                          |  |                                                                                    |  |        |        | /of |
| Time at Start of Route                                                    |             |                    |              |               |                    |                          |  |                                                                                    |  |        |        |     |
| hh mm V    hh mm V    hh mm V    hh mm V    hh mm V    hh mm V    hh mm V |             |                    |              |               |                    |                          |  |                                                                                    |  |        |        |     |
| Registration Number                                                       | 1           |                    |              |               |                    |                          |  |                                                                                    |  |        |        |     |
|                                                                           | 2           |                    |              |               |                    |                          |  |                                                                                    |  |        |        |     |
|                                                                           | 3           |                    |              |               |                    |                          |  |                                                                                    |  |        |        |     |
|                                                                           | 4           |                    |              |               |                    |                          |  |                                                                                    |  |        |        |     |
|                                                                           | 5           |                    |              |               |                    |                          |  |                                                                                    |  |        |        |     |
|                                                                           | 6           |                    |              |               |                    |                          |  |                                                                                    |  |        |        |     |
|                                                                           | 7           |                    |              |               |                    |                          |  |                                                                                    |  |        |        |     |
|                                                                           | 8           |                    |              |               |                    |                          |  |                                                                                    |  |        |        |     |
|                                                                           | 9           |                    |              |               |                    |                          |  |                                                                                    |  |        |        |     |
|                                                                           | 10          |                    |              |               |                    |                          |  |                                                                                    |  |        |        |     |
|                                                                           | 11          |                    |              |               |                    |                          |  |                                                                                    |  |        |        |     |
|                                                                           | 12          |                    |              |               |                    |                          |  |                                                                                    |  |        |        |     |
|                                                                           | 13          |                    |              |               |                    |                          |  |                                                                                    |  |        |        |     |
|                                                                           | 14          |                    |              |               |                    |                          |  |                                                                                    |  |        |        |     |
|                                                                           | 15          |                    |              |               |                    |                          |  |                                                                                    |  |        |        |     |
|                                                                           | 16          |                    |              |               |                    |                          |  |                                                                                    |  |        |        |     |
|                                                                           | 17          |                    |              |               |                    |                          |  |                                                                                    |  |        |        |     |
|                                                                           | 18          |                    |              |               |                    |                          |  |                                                                                    |  |        |        |     |
|                                                                           | 19          |                    |              |               |                    |                          |  |                                                                                    |  |        |        |     |
|                                                                           | 20          |                    |              |               |                    |                          |  |                                                                                    |  |        |        |     |
|                                                                           | 21          |                    |              |               |                    |                          |  |                                                                                    |  |        |        |     |
|                                                                           | 22          |                    |              |               |                    |                          |  |                                                                                    |  |        |        |     |
|                                                                           | 23          |                    |              |               |                    |                          |  |                                                                                    |  |        |        |     |
|                                                                           | 24          |                    |              |               |                    |                          |  |                                                                                    |  |        |        |     |
|                                                                           | 25          |                    |              |               |                    |                          |  |                                                                                    |  |        |        |     |
|                                                                           | 26          |                    |              |               |                    |                          |  |                                                                                    |  |        |        |     |
|                                                                           | 27          |                    |              |               |                    |                          |  |                                                                                    |  |        |        |     |
|                                                                           | 28          |                    |              |               |                    |                          |  |                                                                                    |  |        |        |     |
| Total                                                                     |             |                    |              |               |                    |                          |  |                                                                                    |  |        |        |     |
| New Arrivals                                                              |             |                    |              |               |                    |                          |  |                                                                                    |  |        |        |     |
| Departures                                                                |             |                    |              |               |                    |                          |  |                                                                                    |  |        |        |     |
| Notes                                                                     |             |                    |              |               |                    |                          |  |                                                                                    |  |        |        |     |
| <b>V - Vehicle Types</b>                                                  |             |                    |              |               |                    |                          |  |                                                                                    |  |        |        |     |
| <b>Group</b>                                                              | <b>Code</b> | <b>Description</b> | <b>Group</b> | <b>Code</b>   | <b>Description</b> |                          |  |                                                                                    |  |        |        |     |
| <b>3-</b>                                                                 | 2B          | Bicycle            | <b>5+</b>    | 5P            | Bus (>5 tyres)     |                          |  |                                                                                    |  |        |        |     |
|                                                                           | 2M          | Motorcycle         |              | 5G            | Goods (>5 tyres)   |                          |  |                                                                                    |  |        |        |     |
|                                                                           | 3R          | Pedal Rickshaw     |              | L             | Leg-powered        |                          |  |                                                                                    |  |        |        |     |
|                                                                           | 3A          | Auto Rickshaw      |              | O             | Other              |                          |  |                                                                                    |  |        |        |     |
| <b>4</b>                                                                  | 4C          | Cars-Vans          |              |               |                    |                          |  |                                                                                    |  |        |        |     |
|                                                                           | 4T          | Small Paratransit  |              |               |                    |                          |  |                                                                                    |  |        |        |     |







| TRAFFIC DATA SUMMARY               |      |    |           |               |                          |                                                                      |        |
|------------------------------------|------|----|-----------|---------------|--------------------------|----------------------------------------------------------------------|--------|
| Overseas Unit, TRL, Crowthorne, UK |      |    |           |               |                          | Form H                                                               |        |
| SITE NAME                          |      |    |           | Site Ref. No. | Surveyor(s) & Supervisor |                                                                      | Sketch |
| Date                               | Time |    | Weather   | NOTES         |                          |                                                                      |        |
|                                    | From | To |           |               |                          |                                                                      |        |
| ARM NAME                           |      |    | DIRECTION |               |                          | N = North<br>SP = Survey Point<br>CBD = Central<br>Business District | Sheet  |
|                                    |      |    |           |               |                          |                                                                      | /of    |
| TIME                               |      |    |           |               |                          |                                                                      |        |
| 0600-0700                          |      |    |           |               |                          |                                                                      |        |
| 0700-0800                          |      |    |           |               |                          |                                                                      |        |
| 0800-0900                          |      |    |           |               |                          |                                                                      |        |
| 0900-1000                          |      |    |           |               |                          |                                                                      |        |
| 1000-1100                          |      |    |           |               |                          |                                                                      |        |
| 1100-1200                          |      |    |           |               |                          |                                                                      |        |
| 1200-1300                          |      |    |           |               |                          |                                                                      |        |
| 1300-1400                          |      |    |           |               |                          |                                                                      |        |
| 1400-1500                          |      |    |           |               |                          |                                                                      |        |
| 1500-1600                          |      |    |           |               |                          |                                                                      |        |
| 1600-1700                          |      |    |           |               |                          |                                                                      |        |
| 1700-1800                          |      |    |           |               |                          |                                                                      |        |
| 1800-1900                          |      |    |           |               |                          |                                                                      |        |
| 1900-2000                          |      |    |           |               |                          |                                                                      |        |
| 2000-2100                          |      |    |           |               |                          |                                                                      |        |
| 2100-2200                          |      |    |           |               |                          |                                                                      |        |
| <b>16hrs TOTAL</b>                 |      |    |           |               |                          |                                                                      |        |
| 2200-2300                          |      |    |           |               |                          |                                                                      |        |
| 2300-2400                          |      |    |           |               |                          |                                                                      |        |
| 0000-0100                          |      |    |           |               |                          |                                                                      |        |
| 0100-0200                          |      |    |           |               |                          |                                                                      |        |
| 0200-0300                          |      |    |           |               |                          |                                                                      |        |
| 0300-0400                          |      |    |           |               |                          |                                                                      |        |
| 0400-0500                          |      |    |           |               |                          |                                                                      |        |
| 0500-0600                          |      |    |           |               |                          |                                                                      |        |
| <b>24hrs TOTAL</b>                 |      |    |           |               |                          |                                                                      |        |

16HR-24HR FACTOR

24HR-AV 24HR FACTOR

AVERAGE 24HR AUTO COUNT













