

# NR2C

## New Road Construction Concepts

*Towards reliable, green, safe&smart and human infrastructure in Europe*



For further information : <http://www.fehrl.org/nr2c>

# NR2C

## New Road Construction Concepts

*Towards reliable, green, safe&smart and human infrastructure in Europe*

*April 2008*

With the participation of





# GENERAL TABLE OF CONTENTS

Presentation of the project NR2C.....	9
<b>Part A</b> - From Vision to developments required.....	27
<b>Part B</b> - Some specific innovations developed in NR2C...	65

# TABLE OF CONTENTS

Executive summary

Foreword

<b>0</b>	<b>Presentation of the project NR2C</b>	<b>9</b>
0.1	General	9
0.2	WP0 – global concept	12
0.3	WP1 – urban infrastructure	14
0.4	WP2 – interurban infrastructure	19
0.5	WP3 – civil engineering structures	23

## **PART A - From vision to developments required**

<b>1</b>	<b>Introduction</b>	<b>29</b>
1.1	Road Engineering Vision	29
1.2	Developments required	30
<b>2</b>	<b>New Road Construction Concepts</b>	<b>31</b>
2.1	Vision 2040	31
2.2	Concepts and solutions	32
2.3	Projects and Developments required	34
<b>3</b>	<b>Reliable Infrastructure</b>	<b>35</b>
3.1	Scope of the concept	35
3.2	Directions for solutions	35
3.3	Projects required	37
3.4	Developments required	38
<b>4</b>	<b>Green Infrastructure</b>	<b>41</b>
4.1	Scope of the concept	41
4.2	Directions for solutions	41
4.3	Projects required	43
4.4	Developments required	43
<b>5</b>	<b>Safe and Smart Infrastructure</b>	<b>45</b>
5.1	Scope of the concept	45
5.2	Directions for solutions	45
5.3	Projects required	47
5.4	Developments required	48
<b>6</b>	<b>Human Infrastructure</b>	<b>51</b>
6.1	Scope of the concept	51
6.2	Directions for solutions	51
6.3	Projects required	53
6.4	Developments required	53

<b>7</b>	<b>Making it comes true</b>	<b>55</b>
7.1	Innovation in practice	55
7.2	Innovation attitudes	56
7.3	Rules of play for innovations	58
<b>8</b>	<b>Developments Required</b>	<b>61</b>

## **PART B - Some specific innovations developed in NR2C**

<b>9</b>	<b>Towards more human infrastructure</b>	<b>67</b>
9.1	Introduction to "multi-modal and multi-level design models" of streets	67
<b>10</b>	<b>Towards greener infrastructure</b>	<b>83</b>
	<i>Reduction of nuisance due to traffic</i>	83
10.1	Ecotechnic Road system	83
10.2	Air purification by pavement blocks: NOx reduction by pavement blocks	101
10.3	Improving the mechanical properties of a low noise section - SOFTBLOC – Silent poroelastic overlay fixed on tailored cement block pavement	108
	<i>Preservation of rare resource: re-use material</i>	124
10.4	Development of high performance underlayers with low cost materials and high percentage of re-use	124
10.5	Crack-free semi-rigid pavement incorporating two industrials by-products	134
<b>11</b>	<b>Towards reliable infrastructure</b>	<b>147</b>
	<i>Road maintenance</i>	147
11.1	New pavement maintenance technique aiming at enlarging the overall conditions of application	147
	<i>Innovative small and medium span bridges</i>	156
11.2	Hybrid FRP-concrete sandwich structure with lightweight concrete core for bridge decks	156
11.3	Study of solutions for bridge decks made of Ultra-High Performance Fibre-Reinforced Concrete (UHPFRC) and composite materials (glassfibre)	169
11.4	Detailed design and experimental validation of innovative aspects of a 10m - span composite UHPFRC – carbon fibres – timber bridge	185
<b>12</b>	<b>Towards safer infrastructure</b>	<b>203</b>
12.1	Roadway perception technology using the infrared know-how	203
12.2	Road safety through urban design: contribution of “design models”	216

### **APPENDICES TO PART A: Developments required**

ANNEX I	New age binder design (nano) technologies
ANNEX II	Lifetime engineering for roads
ANNEX III	Asset to management tools
ANNEX IV	Modular prefabricated pavements
ANNEX V	Low temperature asphalt with reclaimed asphalt
ANNEX VI	Bridge eco-assessment
ANNEX VII	TyroSafe
ANNEX VIII	Energy controlled pavements
ANNEX IX	Integrated models for urban design

### **RECAPITULATIVE LIST OF NR2C DELIVERABLES**

# Executive Summary

What will the European road system look like in 2040 ? How can innovation deliver solutions to the challenge of the future, which combines simultaneously growing transport needs and sustainability goals ?, such are the two crucial questions to which NR2C aims to answer.

Consequently its objective were firstly to provide a long term vision of the road infrastructure and secondly to develop specific innovations in three fields : urban infrastructure, interurban infrastructure and bridges.

NR2C has developed long-term perspectives, concrete pilot projects and research recommendations, linking long-term visions and ideas to short-term actions. 'Dialogue and cooperation', 'Creativity and innovation' and 'Short-term and long-term' are the main ingredients of this project.

The project, its organization and the main results provided are presented at the beginning of the report (section 0) .

A vision reflecting society's perception of road infrastructure in the year 2040 forms the basis of NR2C's aim to identify and specify the research required in the field of road engineering to guarantee comfortable and reliable ground transport in a sustainable and environmental-friendly way for the coming decades.

The presentation of the vision, of its four concepts - reliable, green, safe and smart, and human -, and of the corresponding identified developments required constitutes the part A of the present final report.

The part B of the report is a presentation of some specific innovations developed in NR2C.

These innovations are classified, not in accordance with WP fields - urban infrastructures, interurban infrastructures or bridges, but in accordance to their contribution to one of the four NR2C concepts - human, reliable, green, safe and smart infrastructure, previously identified. Of course innovative solutions developed, generally not answer to only one unique concept, but simultaneously to two or more of them, but in this report it has been chosen to link each innovation to the dominant concept addressed.

Consequently, NR2C specific innovations are presented as follows:

- towards more human infrastructure : new design-models for arrangement and development of multi-modal streets, that can be used as a tool for dialogue and co-design between actors
- towards greener infrastructure : Eco-Road System - an integrated road concept, combining new technologies for the reduction of traffic nuisance (noise, air and water pollution), with in addition a special focus of TiO<sub>2</sub> as air purifier ; Roads underlayers with a high percentage of re-use to preserve rare resources. Crack free-semi-rigid pavement using industrial by-products; etc
- towards more reliable infrastructure : as regard roads, new maintenance road processes allowing to perform maintenance works even under bad weather conditions and consequently to reduce traffic congestion by extending possible maintenance seasons ; as regard bridges, several solutions of innovative small and medium span bridges, light, durable, easy to prefabricate and assemble on site.
- towards safer and smarter infrastructure: the use of infra-red technology to improve drivers' vision under bad weather conditions ; in complex urban environments, the improvement of road safety through urban design – interest of design models.

## Foreword

Civil infrastructure systems represent huge public investments and are expected to provide services for very long periods of time. Their use spans several generations during which society will experience dramatic changes. This lengthy time span means that future developments in the transport of goods and people must be assessed and planned well in advance in order to make the right choices, not only for today but also for tomorrow. Looking ahead into the future and considering probable developments in society enables us to search for proper solutions.

The combination of constant increase in the number of road vehicles and the subsequent rise in traffic volumes and axle loads speed up developments like congestion, wear and tear of structures and, last but not least, air pollution and noise emissions. This evolution is going fast, in any case faster than over the past twenty years.

The road sector faces huge challenges, including ambitious demands such as better, quicker and cheaper production, construction and maintenance. To minimize downtime of roads for maintenance activities, the overall quality of the constructions has to be upgraded. The time slots available for repair and rehabilitation works are becoming tighter and tighter, which means that maintenance techniques have to be speeded up. Furthermore, the environmental regulations with respect to air pollution and noise emissions by traffic and the use of natural raw materials are becoming more and more stringent. These developments are also leading to a new series of questions and problems.

It is thus of our responsibility to search what future road infrastructure will look like, in order to initiate today the necessary changes and advancements so that future roads and streets will continue to meet our growing transport needs, in a safer, more effective and comfortable way.

This challenge to preserve for future generations living conditions that are both functional and pleasant, calls for two main conditions:

- to turn our working methods to more global approaches, more centered on “human” aspects;
- to develop efficient techniques, methods and tools, respectful of the environment and energy consumption, in support of renewed and innovating design and management approaches.

This requires a significant effort in the field of research and development.

2040 will be what we build:

*“The most exciting aspect of the future is that we can determine it ourselves”.*

(Charles Handy: *The Age of Unreason*)

The objective of FEHRL is to make a valuable contribution to address each of these new challenges thanks to the abundance of expertise available in every one of its member institutes.

We hope that, after having read this report, you will have understood that our road sector is far more innovative than one could imagine at first sight.

Finally, I would like to thank all those who have contributed to the completion of this ambitious project.



FEHRL President



# 0

## Presentation of the project NR2C

### 0.1 General

#### 0.1.1 SCOPE OF THE PROJECT

On the initiative of FEHRL, the European Commission has set up the innovation project “New Road Construction Concepts (NR2C)”. This project aimed to generate future-orientated initiatives for accessibility problems and issues related to road infrastructure.

Relevant to the sixth Framework Program – priority 6: Sustainable development, global change, NR2C which was a four year project, has started in December 2003, to be completed in December 2007.

Its objectives were, in dialogue and cooperation with all actors concerned such as road infrastructure owners, decisions makers, experts, users, road industry:

1 - firstly, to provide long term perspectives for the road infrastructure (vision 2040), which reconciles future transport needs, expected users and social demands, and sustainability goals; this means to develop new concepts for the road of the future (high quality, cost-effective, low noise, environmentally friendly, safer, risk mitigating, low maintenance, while facilitating traffic mobility and inter-modality)

2 - secondly, to implement concrete short term actions by developing specific innovations that will support this long term vision, these innovations being relevant to three fields : urban infrastructure, interurban infrastructure and civil engineering structures.



#### 0.1.2 PARTNERS

Led by the LCPC, NR2C has involved, directly or indirectly, partners from:

- FEHRL road research institutes:
  - LCPC, leader of a joint unit research which brings together DREIF/LROP and CETE de Lyon – France,
  - DWW – Netherlands,
  - EPFL - Switzerland,
  - BRRC – Belgium,
  - under FEHRL umbrella : DRI – Denmark, KTI – Hungary, ZAG – Slovenia, VTI – Sweden, Ibdim – Poland, as support to FEHRL association which was a core partner by itself;
- engineering and design consultants, road industry:
  - Greisch Ingénierie – Belgium
  - Jean Muller International – France
  - Eurovia – France;
- road owner, with research activities:
  - Autostrade – Italy.

### 0.1.3 WORK PACKAGES

In accordance to the objectives, the NR2C project was divided into four first Work Packages, respectively dedicated to the global concept and each of the three specialised fields:

WP 0: Development of new concepts for the road of the future (leader: T Maagdenberg - DWW)

WP 1: Innovations for urban and suburban infrastructure (leader: JP. Christory – LROP)

WP 2: Innovations for interurban infrastructure (leaders, successively: JC Turtschy, A. Junod, L. Arnaud, N. Bueche – EPFL - Switzerland)

WP 3: Innovations for civil engineering structures (leader: JM. Tanis – JMI);

and two additional, but crucial, Work Packages for dissemination and management:

WP 4: Clustering, communication, co-ordination and utilisation (leader: S. Phillips – FEHRL)

WP 5: Management (leader: B. Mahut -LCPC)

In addition, the project was continuously supervised by two scientific directors (T. Kretz -now Sétra and J. M.-Piau - LCPC).

### 0.1.4 MAIN WORK PROGRESS PHASES

If one consider NR2C timing, three main phases can be identified:

- Phase 1 – survey and analysis

Began in 2004, continued in 2005, this phase was designed to clearly identify future user needs and expectations. It had consisted of enquiries, surveys, focus workshops and brainstorming sessions, to build the vision. In parallel, state of the art reports on innovations in urban, interurban and civil engineering have been provided.

- Phase 2 - assessment and selection

During this phase running to the end of 2006, innovations, feasibility studies, preliminary models have been carefully assessed and the most promising have been selected for further development

- Phase 3 – testing and recommendations

Running to the end of 2007, innovations selected in phase 2 have undergo detailed design, laboratory tests and when possible site pilot tests, leading to specific recommendations.

Finally, in the continuity of the NR2C vision concepts, and taking in account Europe concerns, emblematic future research projects have been identified.

### 0.1.5 PROJECT RELATION TO THE STATE OF THE ART

In order to answer to the question of developments required to face the future, NR2C has adopted an approach consisting firstly to define a vision, and secondly to convert it into research and innovation priority. This approach is very similar to other visions provided in the same period.

The NR2C Vision 2040 takes in account :

- ERTRAC Vision 2020 (whose main themes are: mobility of people and transport of goods, safety and security, environment energy and resources, competitive design and production systems)
- FEHRL Vision 2025 (which started the vision from the perspective of highways and their operation in different future society scenarii), converted to specific requirements)
- ECTP Vision 2030 (European Construction Technology Platform Vision which is articulated around three main concepts : meeting clients' requirements, becoming sustainable and transformation

of the construction sector – the fields considered being cities and buildings, underground, networks and some transversal field such as materials, cultural heritage, quality of life).

However NR2C brings an original contribution that takes in account widely users and stakeholders and goes also deeply in the urban and peri-urban problematic, and most of all gives major place to the “human”.

As regard the development of specific innovations, each field of NR2C (urban, interurban, bridges) has began with state of the art reports based either on European inquiries either on very deep bibliographical studies.

From a global point of view, NR2C mainly takes benefit from :

- SAMARIS (Sustainable and advanced materials for Road and Infrastructures project)
- in the field of pavement : Paramix EC- Project (Road pavement rehabilitation techniques using enhanced asphalt mixture) and will also consider OCDE project – Long life pavement
- in the field of bridges : national reference documents on BFUP, composites, famous at the international level
- and also SAMCO project (Structural Assessment Monitoring and Control)
- synergy with SILENCE to study low noise pavement for urban area
- in urban infrastructure through an inquiry made by PIARC on road innovations in the period 2000-2003

#### **0.1.6 SEMINARS**

Seminars have been organised at crucial periods of the project. Corresponding presentations are available on FEHRL website.

The NR2C launching seminar has taken place as a part of the FeRRM seminar organised by FEHRL, in Brussels, 14-17 June 2004.

At the beginning of the project, several additional seminars and brainstorming have been organised in different European countries to deliver information about the project and cause discussions and reflexions to feed the prospective 2040 vision while collecting waiting and needs expressed in term of innovations. Among them, a seminar specifically dedicated to urban sector must be noticed: the seminar organised by WP1, “La rue du futur” – Paris, 14 september 2004 and 25<sup>th</sup> January 2005

A mid-term workshop has been organised in Brussels on 16<sup>th</sup> December 2005, by FEHRL and DWW. Bringing together representatives from the road related industry, road operators and owners, research institutes, academia and the European Commission, the aim was to inform participants about the progress of the project and to consult them with respect to the approach chosen and their expectations, remarks and adjustments.

At the end of the project, on 15<sup>th</sup> and 16<sup>th</sup> November 2007, NR2C has shared its final workshop with other European Commission road infrastructure related projects. This seminar on road innovation, organised by FEHRL, has linked to prospective NR2C dimension, concrete results and work in progress from the same projects cluster, such as Samaris, Certain, Arches, and Spens.

## 0.2 WPO – global concept

### Participants to WPO

DWW: **Ton Maagdenberg** (WPO leader), M. Sule, M. Koster

LCPC: B. Mahut, JM. Piau,

LROP: JP. Christory

EPFL: L. Arnaud, N. Bueche

FEHRL / ZAG: A. Znidaric, KTI: L. Gaspar, VTI: B. Kalman, DRI: F. Thogersen, ibDIM: A. Adesiyun

BRRC: A. Vanelstraete

Autostrade: M. Luminari

JMI : JM. Tanis

The aim of this work package was to provide firstly a long term vision - which has been used to initiate discussions in seminars and brainstorming, and finally to translate it in terms of developments required for the infrastructural features (accessibility, reliability, safety, etc.).

After having been presented and discussed at the mid-term workshop organized by DWW with the support of FEHRL on 16th December 2005 in Brussels, the NR2C Vision 2040 for the infrastructure of the future (D0.2+D0.3 (PU)) has been completed, finalized and published.

Providing a global vision of the European infrastructure in 2040, this NR2C vision is based on four key concepts representing the dominant characteristics of the society's expectations for the road of the future:

- **Reliable infrastructure**, standing for optimizing the availability of infrastructure,
- **Green (environment friendly) infrastructure**, standing for reducing the environment impact of traffic and infrastructure on the sustainable society,
- **Safe and smart infrastructure**, standing for optimizing flows of traffic of all categories of road users and road construction work safety,
- **Human infrastructure**, standing for harmonizing infrastructure with the human dimensions

Comparing the future with the present situation, the vision identifies research areas (directions of solutions) to face the future.

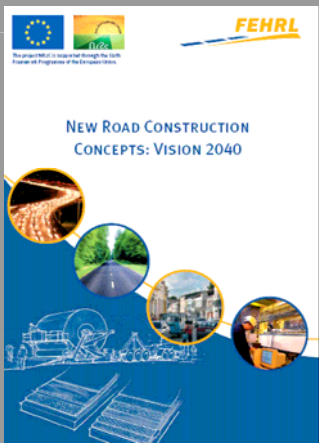
Vision 2040	Characteristics	Construction Concepts	Directions for solutions
 <p>Also available on FEHRL website: <a href="http://www.fehrl.org/nr2c">www.fehrl.org/nr2c</a></p>	Available Durable Reliable	<b>Reliable Infrastructure</b>	<ul style="list-style-type: none"> <li>• Lifetime engineering</li> <li>• Fast, hindrance-free maintenance</li> <li>• Balancing demand and capacity</li> <li>• Asset management tools</li> </ul>
	Energy efficient Sustainable Environment	<b>Green Infrastructure</b>	<ul style="list-style-type: none"> <li>• Saving natural resources</li> <li>• Emission Control</li> </ul>
	Accessible Smart Safe	<b>Safe&amp;Smart Infrastructure</b>	<ul style="list-style-type: none"> <li>• Safe design</li> <li>• Smart design</li> <li>• Smart communication</li> <li>• Smart monitoring</li> </ul>
	Multi-functional Multi usable Public security	<b>Human Infrastructure</b>	<ul style="list-style-type: none"> <li>• Public security</li> <li>• Multi-functional use</li> <li>• Human design</li> </ul>

It also insists on key factor for successful innovation : a shared will to innovate and a full engagement of all the actors.

#### **'Rules' of play for innovations**

- The contributions of the various parties to the development costs.
- The process to be followed with the innovation.
- The decision moments during the process, including criteria.
- The expected completion time.
- An estimate of the probability of success.
- Risk spread.
- How to deal with patents.
- How to deal with specifications with innovations during tendering.

The progress being made in optimising existing concepts will soon no longer meet the demands and requirements and changes in the concepts will be necessary. To achieve these ambitious goals, the sector must become more innovative and move faster towards redesigning existing concepts. Therefore the introduction of new proven research technologies from other sciences such as physics and chemistry is vitally important.

A new generation of problems requires a new generation of approaches in setting up research. In this context and without minimising the importance of other projects listed, NR2C has selected a number of projects as 'Developments required', needing special attention from all stakeholders involved.

#### **Developments required:**

- New age binder design technologies.
- Integrated models of urban (human) design.
- Lifetime engineering for roads.
- Asset management tools.
- Modular prefabricated pavements.
- Low temperature asphalt with reclaimed asphalt.
- Bridge eco-assessment.
- TYROSAFE: optimizing tyre-road interaction.
- Energy controlled pavements.

These projects will provide the sector with new basic knowledge standards for trend setting developments and innovations required to face the future with confidence. These 'Developments required' projects are also synonymous with high research investments in the initial stage of development through with European-wide cooperation and governmental support and funding are the key factors to success.

#### Deliverables

D03 – New Road Construction Concepts : Vision 2040, which has been published by FEHRL and is available on FEHRL website

D05 - Facing the future - Developments required, whose content is reproduced in part A of the present report

### 0.3 WP1 – urban infrastructure

#### Participants to WP1 :

LROP: **JP. Christory (leader)**, D. Miet, E. Barré, D. Sicard (LROP) (Topic 1)

LCPC: B.Mahut, JM. Piau

Autostrade : M. Luminari (Topic 2)

BRRC : A. Beeldens (Topic 2 -TiO2)

VTI: B. Kalman

Regarding urban infrastructure, it is firstly important to notice that a street is not a road : it is more complex, it is the support of multiple uses, the place of coexistence of the underground and the aerial techniques, of the commercial and not merchant exchanges, etc., and it plays a particular structuring role in the urban area.

Secondly, linked to the questions of the evolutions of cities and displacements, the question of the place of the car in the town of the future is raised.

Thirdly, taking into account delay for evolutions and necessary inertia to change of urban environment which must respect existing asset and be progressive to be acceptable, it is probable that future evolutions in urban area within 2040, will be probably more based on progressive transition, than on a deep technological rupture.

Anyway, whatever the assumptions regarding the place of the car, and the evolutions, the following expectations remain the most important and will have to be satisfied :

- A more human city

All discussions with stakeholders highlight the importance to place “human” in the center of reflexions when working on cities evolution and more focusely on streets and transport infrastructure evolutions. This supposes to develop co-design with highest participation of users and residents, to favorise global approach of problems, with multidisciplinary competences, technique remaining only a support, a tool.

- A more “mobile” city

Citizens mobility demands will continue to increase, accompanied by the necessity of accessibility for all, possibility of choice, etc. This means to increase and diversify the various forms of mobilities by means of adaptability of the street, intermodality, new form of mobility (example car sharing), and due to the scarcity of space, to share space and time, to prioritise the use.

- A city without harmful effect

One find under this item of course the expectations of reduction of pollution (noise, air, etc) and also reduction of disturbance both during works, and exploitation, for example with the concept of “furtive building sites” and an increased use of prefabrication.

Answering to these expectations pass by evolutions not only technical but also on economical, organisational, urban logistic aspects. Innovations developed or studied in NR2C tends to bring some answers to some of these questions by means of :

- the development of design models providing tools for analysis and assessment of existing and future sites, that can be used as well as design tools to pass from the program to the draft of a project of public space and multimodal-infrastructure, and as a support of dialogue between the designers, the owners and the inhabitants engaged in a true process of co-creation.
- the development of an ambitious program regarding the nuisance-mitigating infrastructure through a prototype system of integrated technologies to contribute to reduce nuisance (noise, vibration, and air, solid and liquid pollution). This includes a particularly original work regarding mitigation of air pollution in tunnels first, in roads and streets secondly (resp Autostrade – M. Luminari). It includes the verification of the use of titane dioxyde as air purifier on upper layer of pavement or building surfaces in order to reduce air pollution due to traffic (resp BRRC – A. Beeldens)

Consequently this work package has been organized within two main topics.

• **Topic 1 – design-models for multimodal streets (led by LROP)**

When a street has to be rearranged, the process from program defined by the decision maker to the final solution implemented is long, with iterative steps. One difficulty encountered, in present practice, derives from the difficulty of dialogue between specialists (architects, urbanists, etc..) and other actors involved. One of these difficulties is linked to the fact that specialists when suggesting choice of solutions refer to implicit models, founded on their knowledge and experience. The advantage of design models developed in NR2C is to clearly explicit criteria for different models of streets, with “advantages” and “disadvantages” of each possible solutions for example as regard ambiance, safety, etc.

As an example, for a given street, depending on the program and consequently the choice of the most appropriate design model, the implementation of such design models can result solutions as illustrated below. The space of the street is differently shared between pedestrians and vehicles.

The figure illustrates the design models for multimodal streets. It includes a central table titled "SECTIONS EN TISSU URBAIN DENSE" comparing five models: Rue à Niveau, Rue Mixte, Rue Rideaux, Rue Disponible, and Rue Fonctionnelle. Above this table are five document pages, each titled "LA RUE A NIVEAU" or "LA RUE A RIDEAUX", "LA RUE DISPONIBLE", "LA RUE MIXTE", and "LA RUE A NIVEAU". To the right is a document titled "(Paris)" showing cross-sections and diagrams. Below is another document with a grid of criteria.

available in French and in English



Before

Example of solutions depending on the choice of the design model

Twenty design-models have been developed, accompanied by the methodology of use. The methodology has been successfully implemented in Wattrelos city, near Lille in France.

Deliverables:

**D11** – Expectations and needs for innovation in urban roadway – system – A vision for 2040

This deliverable, focused on urban expectations and needs is completed by the conclusions of the two seminars organised by WP1 at the beginning of NR2C.

**M11** – Check specification and preliminary concepts for the integration of public transit platforms in urban settings

**D12** - Specifications and concepts for the integration of public transit platforms in urban settings

This deliverable explains what is a model design, how it can be used for the designing of streets and how new design models can be built .

**D13** – Specifications and preliminary concepts for the design of multi-modal streets

In addition to D12, this deliverable presents the interest of design models for road safety problems in complex urban city and develops the implementation of design models to Wattrelos city.

(see 9.1 and 12.2)

• **Topic 2 – Ecotechnic Road System (led by Autostrade: M. Luminari, with BRRC: A. Beeldens for contribution on TiO2)**

Ecotechnic Road System (ERS) is a concept of an integrated infrastructure, based on the most innovative technologies in order to minimize globally pollution and disturbance due to traffic (noise, vibrations, air and water pollution).

The nuisance mitigating road infrastructure solutions defined as ERS, are composed by three subsystems:

- Pavements subsystem (i.e. resilient, resonant and reservoir pavements);
- Barriers subsystem (i.e. anti noise, air depollutant, safety and green barriers);
- Auxiliary subsystem (i.e. air cleaning unit, ventilation unit, ground catalyser, photo catalytic material and TiO2 coating).

Ecotechnic Road System

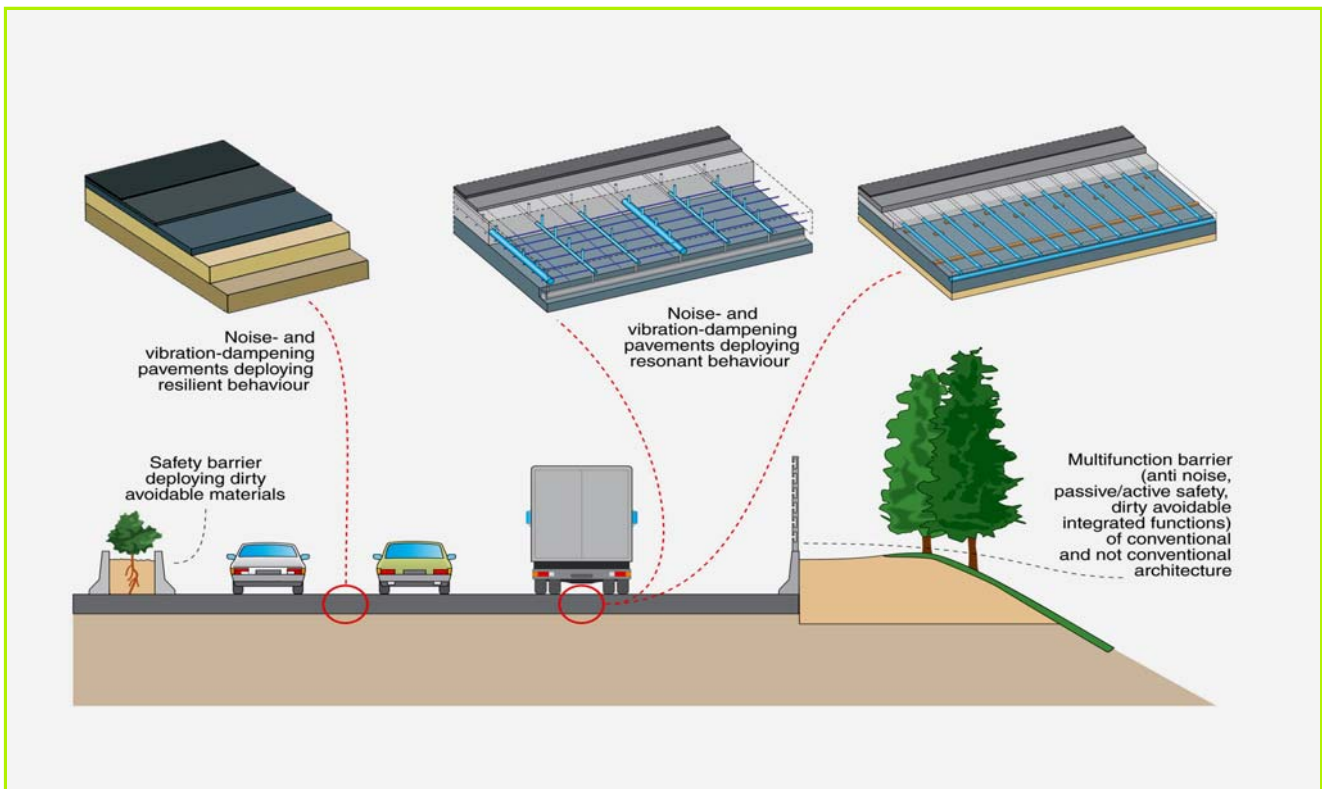

The main results, as regard nuisances mitigation, are:

**Noise** : different solutions are available in order to reduce noise nuisance via road pavement and barrier. Optimised solutions reaching 12 dBA can be obtained with contribution from 3 to 6 dBA from road pavement and till 8 dBA from barriers.

**Pavements:** It is recognized that quiet pavement systems develop effective noise-controlling pavements concentrating on sound absorbing properties, micro- and macro-texture characteristics. However under NR2C, questions regarding the duration of the reduction and the degree each different system contributes are under performance analysing by monitoring in Italy on motorway network the experimental pavements using resilient and resonant technology (euphonic and ecotechnic types) originally conceived, lab prototypised and small & full scale implemented during SIRUUS (Silent Roads for Urban and Extra-Urban Use) project taking into account an idea by the Romans 1700 years ago to control low frequency noise.

- The resilient type, with "dumping" behaviour, is constituted by a bituminous porous double layer (2 cm of 0-6mm on 4 cm of 0-16mm) on the light-weight aggregate bituminous mixture road base course (15 cm of 0-25mm) as energy absorbing semi-porous lower layer in order to decrease the mechanical impedance reflecting also on the acoustical behaviour improvement.

- The euphonic and ecotechnic types of the SIRUUS pavement concepts are variations of the resonant typology that consists of two layers of porous asphalt (constituted by a porous wearing course 0/6mm and a porous base course 0/16mm) connected to a concrete road base course with localised Helmholtz resonators. The third layer can be obtained also as transition or disconnection layer carried out by diffused resonant cavities obtained by light-weight cement mortar. The Helmholtz resonators are designed to absorb noise over the range from 100 to 250 Hz widening the absorption range of 400 Hz – 1200 Hz carried out by the double layer at the top.

- The Ecotechnic pavement which was originally developed for street traffic, is a multi-layer pavement including a top layer of porous asphalt 0/5mm, a base layer of porous asphalt 0/24mm, and a metallic panel disconnection layer.

**Barriers:** innovative barrier solutions have been developed

- coupling the traditional antinnoise barrier types, eventually with self adaptive height and inclination with acoustic changing characteristics by folding panels, and restrain integrated road safety system, eventually with dirty avoidable characteristics by sprayed TiO<sub>2</sub> (screen close to source);

- improving the performance characteristics trough new materials and/or structure types as light weight concrete vertical panels constructed using expanded clay as aggregates (novel-shaped noise barriers & optimisation of acoustic absorption properties);

- adding new functions as atmospheric pollution control/abatement (as active carbon particle) and traffic management carrying out an active integration in the nuisance mitigating infrastructure (novel-shaped noise barriers & optimisation of acoustic absorption properties).

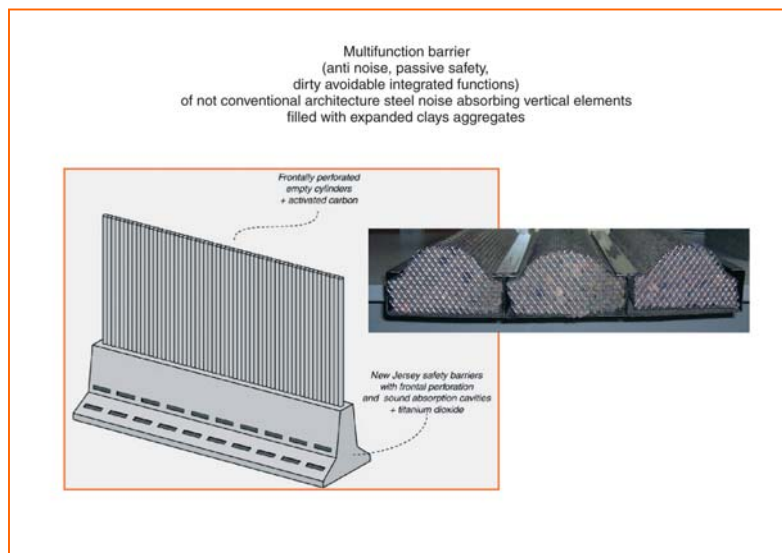

**Water:** The modelling has permitted to define an optimal solution of reservoir pavement characterised by a retention time which can vary by few hours to some days also depending from the event type (run-off and spill-off), precipitation intensity and dangerous discharged liquid type. The collection system characteristics studied for the reservoir pavement can guarantee the average pollutants abatement until 50%.

**Air pollution:**

**Air cleaning:** The volumes of a road tunnel (including the tunnel exits affected by the plume effect) and of a rural and urban road U shape sections, were analysed by an original numerical simulation model. This model was developed by taking into account the fluid-dynamic effect of road-vehicle motion in order to carry out the map of atmospheric pollutant concentrations within the foregoing volumes in near-to-real conditions. The analysis was extended to various typologies of U shape road sections (cuttings, false cuttings, canyons) and positions of the surrounding land and takes account of the variation in the meteoric ventilation.

With the use of an innovative CFM method (Control Function Method) an objective measure of the environmental impact of road traffic for the foregoing volumes was obtained. The introduction of air-cleaning active systems in the tunnel and at the exits was considered.

**Photo catalytic material:** the environmental friendly solutions of TiO<sub>2</sub> as photo catalyst in dispersion phase for antinoise barriers and in coating for tunnel walls which have been studied and carried out on site are under test application to be verify the dirty avoidable abatement and air purification effect over time the applications.

Regarding TiO<sub>2</sub> for the purifying of air the follow up of test application on site has been done (resp A. Beeldens - BRRC). If TiO<sub>2</sub> has rather clearly demonstrated efficiency in laboratory, it appears more difficult to assess efficiency on site due to very small quantity to be measured and perturbing factors such as wind for example.

A complete detailed design has been done for two solutions respectively for rural/suburban and for urban environments, whose global quality efficiency regarding nuisance mitigation.

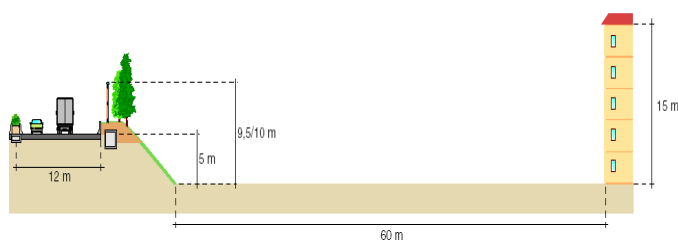

solution 1 for rural/suburban environment

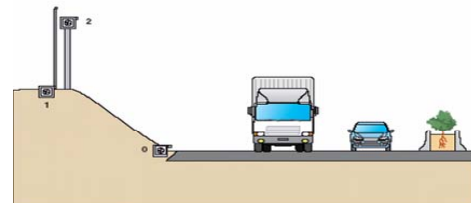

solution 2 for urban environment

Deliverables:

These documents are RESTRICTED;  
if interested, please contact M. Luminari [mluminari@autostrade.it](mailto:mluminari@autostrade.it))

- D14 - multi-functional infrastructure feasibility studies and air cleaning model
- M12 – Analysis of the multi-functional infrastructure feasibility
- D15 – Preliminary design of multi-functional infrastructure
- D16 – Detailed design and pilot study of multi-functional infrastructure

(see 10.1, and 10.2 specifically on TiO<sub>2</sub>)

## 0.4 WP2 – interurban infrastructure

### Participants to WP2:

EPFL: successively JC. Turtschy, A. Junod, L. Arnaud, N. Bueche (leader and innov 21A)

BRRC : A. Vanelstraete, P. Bauweraerts (Innov 21A)

LCPC : JM. Piau, J. Dumoulin (Innov 22), T. Sedran (Innov 21B)

Eurovia :JP. Marchand (innov 23)

DWW : successively Joop Van Zwieten, R. Van Gent

FEHRL (KTI :L. Gaspar; ZAG: D. Kokot; VTI: B. Kalman; DRI: F. Thogersen (Innov 21A et 25)

Autostrade : M. Luminari

After a state of the art on innovations in the field of road infrastructures, based on a wide inquiry through European countries, this work package has focused on the development of five innovations.

The state-of-the art review has clearly demonstrated the typical trends of innovative road construction, rehabilitation and maintenance are as follows:

- the use of very high quality (premium) basic materials eventually with their special treatment,
- the establishment of sophisticated construction, rehabilitation and maintenance techniques utilizing up-to-date scientific achievements,
- the development of special measures for enhancing traffic safety even in extreme conditions,
- decreasing the whole life (life cycle) costs of road pavements by constructing long-life variants with infrequent maintenance and rehabilitation need, and, consequently, minimal traffic disturbance,
- the wider use of industrial by-products in road engineering without reducing pavement performance,
- the wider use of recycling (eventually-re-use) of bound pavement structural layers in order to reduce the need for primary basic materials without jeopardising the performance of pavements,
- giving priority to low-energy pavement structural variants reacting to the ever increasing energy prices and the limited availability of crude oil supplies,
- there are some “blue sky” type innovations which utilize some new scientific results eventually coming from science areas far away from highway engineering.

As regard the five innovations developed in WP2, each of them deals with solutions for one or more of the NR2C Vision concepts and mainly with the green infrastructure by preservation of rare resources via recycling and use of industrial by-products.

**Innovation 2.1A** Design of high performance underlayers underlayers with low cost materials and high percentage of re-use (EPFL-Switzerland, BRRC-Belgium, and other FEHRL-laboratories as VTI, KTI, DRI).

The goal was to evaluate if the growing share of recycled aggregate used in asphalt high stiffness base courses influences the asphalt mechanical properties. It was the aim of this study that no significant loss in asphalt fatigue, deformation and durability characteristics counterbalances the environmental and economic benefits coming from the use of recycled material.

The project aimed to optimize the design of mixes with high percentages of recycling material so as to guarantee their long-term performance. In this innovation, three different mixes were designed, optimized and compared, namely with 0 %, 25 % and 40 % reclaimed asphalt. After an extensive laboratory study performed by BRRC, the selected solutions have been further studied in a full-scale ALT -Accelerated Load Testing facility in LAVOC. The structure tested has been instrumented with strain gauges, deflection and temperature sensors in order to analyse its performances. Fatigue behaviour as well as low temperature behaviour was investigated. In addition to the ALT, tests on large slabs with high temperature conditions, as well as other laboratory tests on mixes and binders have been performed by BRRC, LAVOC and FEHRL laboratories (DRI, VTI, KTI).



This study led to the conclusion that no negative effect has been found by using a high percentage of reclaimed asphalt. However key parameters as for instance the mix design and RA properties require special attention.

(see 10.3)

#### **Innovation 2.1B** Crack free semi-rigid pavement incorporating industrial waste (LCPC-France)

The goal was to evaluate if the natural cement concrete shrinkage can be compensated by adding industrial by-products (steel slag, fly ash) with swelling ability to the mixture. The consequences of the use of additional CaO have been also tested. The main idea was to minimise (even to stop) the cracking of hydraulically bound layers and so, to avoid the reflection cracking in the asphalt layers built on them.

On the basis of the bibliographical analysis, a set of constituents has been selected which could be relevant to produce well-graded aggregates with a swelling behaviour and mechanical performances similar to that of cement treated well-graded aggregates. A method potentially useful to make the design of such mixes has been described. Preliminary tests have been done in hot conditions (higher than 80°C) in order to accelerate the mechanical performance increase as well as swelling in order to verify the feasibility of the innovation proposed. Promising results were obtained as far as mechanical performance were concerned but unfortunately technical difficulties were encountered to develop a reliable free swelling test adapted to such well graded aggregate mixes. A promising prototype has been designed and tested but it still needs improvements which could not be done in the duration of the project to really check the feasibility of the proposed concept. More research would be necessary.

(see 10.4)

#### **Innovation 2.2** Use of the infra-red characteristics of materials to improve drivers' visibility (LCPC-France).

The goal was to enhance the traffic safety by improving the drivers' visibility among unfavourable conditions (darkness, fog etc.). The use of infrared image technique can be the solution.

This project aimed to address elements of interurban roads that can be modified to turn them more cooperative for on board automotive infrared vision systems. It mixed an experimental approach on real sites and in fog tunnel, infrared emissivity measurements with a dedicated apparatus developed for pavement surface characterization and simplified numerical simulation of road scene and attenuation by fog according to the size of water droplets distribution. Comparisons between

experiments and simulations were done. Experiments on road site and in fog tunnel allowed us to validate numerical simulations. Numerical simulation tools developed has permitted to evaluate the size of cooperative elements of infrastructure required to be perceptible on infrared images by taking account the characteristics of on-board infrared vision system used. Nevertheless, experiments have also permitted to verify that improving contrast on infrared images by generating a thermal excitation on infrastructure typical elements had to be favour in front of reducing their emissivity in foggy night conditions. Finally, recovering energy from road could be a sustainable solution to generate active thermal elements for on board infrared vision system.

(see 12.1)

**Innovation 2.3.** New maintenance technique aiming at enlarging the overall conditions of application (Eurovia-France)

The aim was to evaluate whether asphalt laying activities can be performed without detrimental consequences under extreme weather conditions (too low or too high temperature, rain etc.). The proposed innovative techniques was supposed to ensure the required asphalt quality and not to increase the construction costs considerably.

This innovation consists in the development of new maintenance techniques and procedures aiming at expanding the overall conditions of application of mixtures for pavements. The benefit of such an innovation is to reduce the impact of the weather conditions on the quality of placing of pavement mixtures, and consequently on the mechanical properties and behaviour of the road structure. Another benefit is the reduction of the impact of road closure due to maintenance on the road users, as it would be more likely to carry out pavement maintenance at more opportune times or periods throughout the year.

(see 11.1)

**Innovation 2.4.** Improving the mechanical properties of a low noise section (VTI-Sweden, ZAG-Slovenia)

The aim of this innovation initiated in a later phase of NR2C WP2 activities was to evaluate (and eventually to improve) the functional and the mechanical properties (durability) of low-noise poroelastic layers built on cement concrete blocks. Laboratory and site tests have been performed for the evaluation of these properties.



(see 10.5)

At the end, WP2 has highlighted, in liaison with WP0, research directions for future possible projects that could be performed (D23) in the field of interurban infrastructure. They are included in the list of proposals for future research projects in appendix to the present report.

### Deliverables

D21 - State of the art on road innovations

D22 - Concept and design of selected innovations for interurban infrastructure

This deliverable is based upon separate technical reports respectively dealing with each of the five innovations developed in WP2, completed by a synthesis report.

Innov 21A Development of high performance underlayers with low cost materials and high percentage of re-use

Innov 21B Crack-free semi rigid pavement incorporating two industrial by-products

Innov 22 Roadway perception technology using the infrared know-how

Innov 23 New maintenance technique aiming at enlarging the overall conditions of application

Innov 24 Improving the mechanical properties of a low noise section

D22 - Development, Assessment, and Application of Innovations for Interurban Infrastructures – Synthesis report

The synthetic presentation of each innovation in D22, is reproduced in part B of the present final report;

D23 – Concept and research programme for future interurban infrastructures

## 0.5 WP3 – civil engineering structures

### Participants:

**JMI : JM. Tanis (leader)**, and successively M. Nicolas, M. Cardin  
LCPC: F. Toutlemonde, B. Godart, P. Rossi, T. Kretz, B. Mahut , JF. Caron, R. Le Roy  
Cete de Lyon: J. Resplendino, S. Bouteille  
EPFL: T. Keller, E. Schaumann  
Greisch : V. Ville de Goyet, F. Gens  
FEHRL: P. Weiss

Before designing new bridge solutions, WP3 has began with a very complete state of the art on bridge innovations (D31 - resp JM. Tanis). This D31 includes :

- Main needs and problems on civil engineering structures
- General view of new materials applications (high performance steel, Ultra high performance fibre concrete, fiber reinforced polymers, other materials,
- Owners and designers expectations : this section being mainly based on interviews of specialists, designers, architects, owners, etc.
- Evolution of civil engineering structures, with a particularly interesting analysis of the evolutions made in the past which highlight that rare disruptions are linked to new materials
- Vision on new bridges for the future.

The work has been pursued with deliverable D32 - New material properties and modelling rules (RE) (resp F. Toutlemonde LCPC and E. Schaumann EPFL) which provides to engineers and design consultants the necessary information for the design and calculation of bridges using ultra-high performance fiber-reinforced concrete or fiber reinforced polymers.

Finally, considering the fact than more than 90 % of bridges are current bridges, NR2C has been focusing on short span bridges and in particular small industrial light structures easy to assemble on site, and likely to be used alone for smallest spans or themselves supported by structural elements, when used transversally, for most important spans.

The main idea of the design was to combine new materials, using the best performances of each material, including possible use of wood as a renewable building material.

Consequently, three main solutions families have been investigated :

- element of sandwich slab, combining UHPFC and FRP, filled with lightweight concrete
- solutions based on UHPFRC : first with UHPFRC alone, secondly with additional materials such as FRP or steel plates, and prestressing when relevant.
- element of structure combining wood beams, slab UHPFRC, and FRP at the bottom of wood.

### **Element of sandwich slab with lightweight concrete**

The main advantage of this type of elements is that they are very easy to execute on site or to prefabricate: it is easy to pour concrete on a whole surface ! But the difficulty is to have a lightweight filling material, sufficiently light to significantly reduce deadload, and also sufficiently “resistant” to be able to transfer minimum efforts : a particular difficulty being at the bottom junction between FRP and lightweight concrete.

To investigate this solution, it is clear that experimental approach by laboratory testing was necessary to try to assess the experimental behaviour of such an element, in addition to preliminary calculations. It is indeed always difficult to predict the practical failure mode when different materials combination, due to the uncertainty on efforts transfers from a material to an other. An advantage also of the experimental approach is that it allows to compare different detailing solutions and to identify solutions whose behaviour is the most satisfactory, and also to identify models the most representative in order to compare further improved solutions.

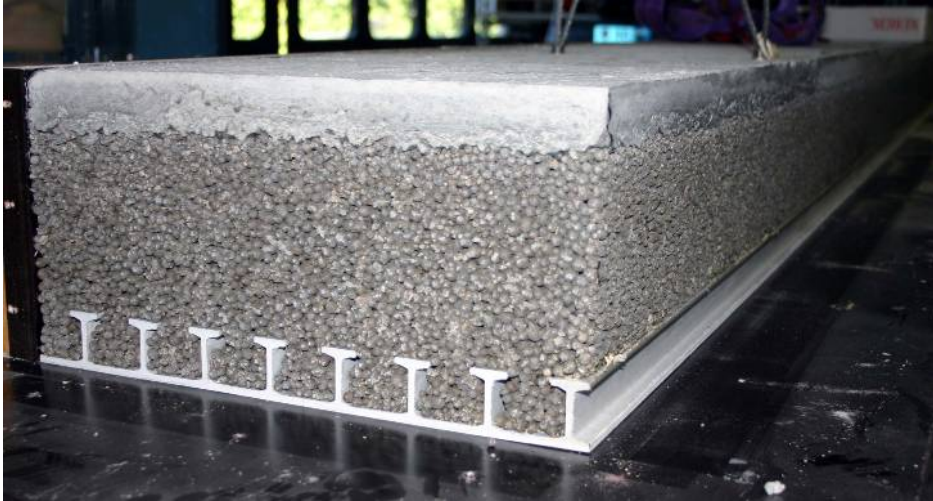

This solution has been studied and tested by EPFL.

(see [11.2](#))

### **Solutions based on UHPFRC**

For these family of solutions, the problem is slightly different, because these solutions do not refer to materials whose behaviour, or behaviour when materials put together is unknown. Consequently the approach for this solutions family can be based on calculation, the problem being to optimise the design versus material performances and in practice versus also authorised deflection. Indeed, this latter criteria which is not a problem for present current road bridges, becomes important when considering light structures as permitted by use of new materials. In this study deflection/span length has been limited to 1/350.

This family of solutions has been investigated by calculation by Cete de Lyon. It has been decided to consider two span lengths, 10 m and 25 m, regarded as the two basic useful span lengths for most of current bridges.

This approach has been pursued till the economical assessment of the different bridge deck solutions, considering the actual condition of material cost, in order to identify the most short term promising as regard economical point of view.

(see [11.3](#))

### **Element of structure combining timber beams, slab UHPFRC, and FRP at the bottom of the wooden beams**

For this last family (with timber beams), the objective was to study a very innovative structure, taking into account possibilities offered by new materials (UHPFRC and FRP) and also the advantage of a traditional material such as wood, whose sustainable advantages give it a renewed interest.

But this type of solutions raises the problem of assemblies : assemblies of FRP with wood, assemblies of wooden beams with concrete slabs, and moreover, the problem of the choice of the assemblies type and its execution mode (for example glue or mechanical connection and which type of mechanical connection ?), the problem of the behaviour of assemblies, and consequently the problem of the efforts transfer from a material to an other one.

Clearly for this third solution, the approach needed an experimental laboratory test on a structural element.



This solution whose detailing and design has been progressively improved till final solution to be tested at LCPC, has been studied by JMI, Greisch, LCPC, LCPC-LAMI. LCPC-LAMI has been in particular in charge of preliminary studies and laboratory tests on different assembly solutions in order to identify the best solutions to be adopted for the structural element to be tested at LCPC.

(see 11.4 and 11.5 )

#### Deliverables:

D31 – State of the art review – a vision of new bridges

D32 - New materials properties and modelling

It provides to designers the necessary characteristics for the design and calculation of bridges using ultra-high performance fiber-reinforced concrete or fiber reinforced polymers

D33 – Preliminary design of innovative solutions

M34 – Selection of solutions for detailed design

D34+35 : Two separate reports have been delivered for the two solutions respectively tested at EPFL and LCPC:

D34+35 - Hybrid FRP concrete bridge desk, tested at EPFL

D34+35 – Composite UHPFRC – carbon fibres – timber bridge desk, tested at LCPC



# Part A

**From the Vision to developments required**

## Contributors

**Ton Maagdenberg**, author, DWW (Netherlands)

Adewole Adesiyun, IBDiM (Poland)

Laurent Arnaud, EPFL (Swiss)

Nicolas Bueche, EPFL (Swiss)

Jean-Pierre Christory LROP (France)

Laszlo Gaspar, KTI (Hungary)

Björn Kalman, VTI (Sweden)

Martijn Koster, DWW (Netherlands)

Marcello Luminari, Autostrada (Italy)

Brigitte Mahut, LCPC (France)

Jean-Michel Piau, LCPC (France)

Maya Sule, DWW (Netherlands)

Jean-Marc Tanis, JMI (France)

Finn Thørgersen, DRI (Denmark)

Ann Vanelstraete, BRRC (Belgium)

Aleš Žnidaric, ZAG (Slovenia)

# 1

## Introduction

### 1.1 Road Engineering Vision

Today, a world without roads, cars, motorcycles and bicycles is almost unimaginable. The entire road infrastructure with its diversity of transport concepts now has a prominent – almost dominant – position in our society. The question is therefore not so much whether there will still be a road infrastructure in the future, but rather how will society view these mobility facilities in, say, thirty or forty years' time.

Comparing the road infrastructure and means of transport of today with those of forty years ago, it becomes clear that in the next forty years' time everything will again look a lot different to how it looks today. Societies are constantly developing and, consequently so are people's requirements regarding the use, structure and design of the road infrastructure – not just roads in urban areas (urban roads), but also the motorways (interurban roads) between the major European cities. It is also quite conceivable that the future construction and design of infrastructure constructions such as bridges and tunnels will be subject to different requirements. In view of the lengthy time span of 10 to 15 years between planning infrastructure facilities and its actual completion, followed by an operational period of at least 25 years, more clarity of these future needs, demands and requirements becomes essential in order to make the right choices for today. Making the future more identifiable and tangible reveals the gaps of knowledge and indicates which new technologies will have to be developed to meet the future demands and requirements.



More clarity of these future needs, demands and requirements becomes essential in order to make the right choices for today. Making the future more identifiable and tangible reveals the gaps of knowledge and indicates which new technologies will have to be developed to meet the future demands and requirements.

Besides generic developments like shortage of clean environment, space and energy, spotting and extrapolating the social and economical trends and technical advances offer starting-points for forming a more realistic image of the future and the associated needs and demands related to road transport. The results of these exercises have been presented by NR2C in its document "New Road Construction Concepts: Vision 2040". Within the framework of this NR2C project, this vision is a realistic and most likely description of future society and shows what the world might look like in (in this case) thirty-five years and how society thinks about use, design construction and maintenance of infrastructure for the coming decades. This Vision 2040 has provided the basis of NR2C's aim to identify and specify the research activities, required in road engineering to guaranty to some extend convenient, comfortable and reliable ground transport in the next decades.

The document "Facing the future – developments required" is a follow up of NR2C's Vision 2040 report and looks more deeply into the research activities required to produce real progress in facing the future demands of society, road authorities and other stakeholders. For a better understanding of this finishing touch and placing NR2C's recommendations in the right framework, relevant passages from the Vision 2040 document will return in this present document.

## 1.2 *Developments required*

The 'Vision 2040' document concludes that future infrastructure research must be focused on a set of four main social questions/demands. These are the 'new road construction concepts': Reliable infrastructure, Green infrastructure, Safe & Secure infrastructure and Human infrastructure. Each concept has been developed into various 'directions of solution' or 'domains of research, including examples of potential projects. All these projects reflect a common interest within Europe of both the public and the private partners in the field of road engineering.

It is common knowledge that the road-engineering sector does not have the appeal of the most sparkling innovative industry. Through incremental upgrades, the road-engineering sector has been able to meet the growing road transport demands over the last decades. Without drastically changing the concepts of design and methods of physical/mechanical material testing, the sector has managed to improve the performance of road infrastructure and related components.

The complexity of infrastructure works and the complexity of the problems requiring solutions are growing. Due to their technical limitations, existing concepts, common models and testing facilities will no longer be able to generate adequate solutions in the long run. A new generation of problems requires a new generation of approaches to setting up research. However, lack of adequate investigation tools and fundamental knowledge about the subject make it difficult to provide solutions of the quality required and thus hinder trend-setting developments.

This situation sounds familiar to every European country. Notably with respect to the road infrastructure sector, terms like 'traditional', 'conventional' and 'lack of sex appeal' are frequently used to describe the sector. Nevertheless in many/most European countries, the need to develop fundamental knowledge about the subject is hampered by lack of interest among policy makers and consequent lack of funding. At national level, the motto is 'Wait and see'. At times however, new sources of more sophisticated and relatively fundamental knowledge must be tapped to offer the market impulses for developing new products, concepts, models and technical tools. In view of the common interest, particularly projects crossing the traditional borders need a European-wide investigation and cooperation impulse.

NR2C stands for 'Let's go and see' instead of 'Wait and see'. Without diminishing the importance of other projects listed, NR2C has selected a number of projects requiring the special attention of all stakeholders involved. For each of the four road construction concepts suggested, a few critical projects are recommended in Chapters 3 to 6 under the denominator 'Developments required'. These projects will provide the sector with new basic knowledge standards for trend-setting developments needed to face the future with confidence.

# 2

## New Road Construction Concepts

### 2.1 Vision 2040

The seeds of tomorrow's European road networks are sown today. The lengthy time span between planning infrastructure objects and its actual completion force policy makers and road engineers to take long views. Neglecting the future can result in disinvestments because of the increased risk that the functionality of the planned new infrastructure becomes outdated soon after completion. Although nobody is capable of predicting the future exactly, it becomes less mysterious by means of spotting, interpreting and extrapolating social, economical and mobility related trends and technical advances. A confrontation of these trends with the general generic developments, which will emerge in all European countries sooner or later, will help to give still more clarity of the potential image of the future.

#### Generic developments

- **Shortage of clean environment:** including air pollution from cars
- **Shortage of energy:** the natural oil resources are scraping the bottom of the barrels
- **Shortage of space:** for housing, working, living, recreation and transport,

But also:

- **Increased demand for mobility:** amongst others resulting from increase in leisure activities and increasing of single households,
- **Increased individual demands:** everybody enjoys driving a car, but nobody wants to see a road, hear the traffic or smell exhaust fumes.

In accordance with democratic constitutions, the best predictable image of the future will be a balanced mixture of all these – to a certain extent – conflicting trends and developments. There must be sufficient focus on the economic interests of well functioning infrastructure and other public spaces as well as the impact of this use on the neighbours (communities and natural habitats) of these infrastructure and public spaces.

Starting from the same ingredients (trends, developments and technical advances), nine European countries have established their own image of the future by means of workshops. These individual visions and several recently presented visions of other organisations have been fused to NR2C's Vision 2040 with respect to road transport. A brief impression of this vision with its typical characteristics in bold type is given below.

High priority will be attached to the **environmental** friendliness of road transport. New transport systems such as road trains combined with advanced traffic management systems provide efficient, smooth and **low energy** transport of goods. Zero emission vehicles with silent tyres, combined with new noise absorbing road surfaces will reduce air and noise pollution. Underground or covered roads will improve the aesthetic features of the infrastructure and create space for new, non-transport related functions. **Multi functional** use of the third, vertical dimension of the square meters occupied by infrastructure is being planned. In this context, special attention is paid to **public security**. Due to lack of space for excessive expansion of road networks, city planners have returned to the principle of compact cities in order to reduce traffic demands. As a result of this compact city concept, suburban roads are transformed into **multi-usable** streets serving the **safety** of all kinds of users of the public space. However, expansion of road networks in urbanised areas will only be considered if it can provide a major contribution in terms of relieving congestion. Thus traffic congestion will continue to be a familiar problem. The image of an environmentally-friendly sector with high **sustainability** standards

will be completed by maximising the recycling of demolition waste to minimise the use of new raw materials and the subsequent impact on natural resources and habitats.

The economic interest of road transport will be served by infrastructure that is **reliable** and **available** around the clock. New construction and maintenance techniques have been introduced to upgrade and rehabilitate the old (existing) network and to build new roads to complete the networks fast and cost-effectively. Roads are built to high quality and **durable** standards, resulting in low maintenance. The need for low maintenance helps minimise 'downtime' and optimises availability of the road network. Road construction becomes flexible by designing according to a modular multi-layer concept. Smart and fast maintenance techniques are developed to reduce 'downtime' of the road, for example

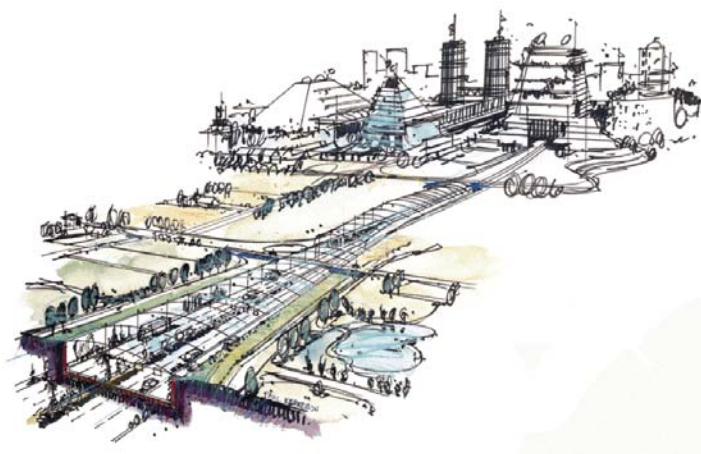

surface treatment sprays to revitalise surface properties and prefab surface layers (pavement on a roll) allowing partial and rapid replacement and upgrading of pavements. New intelligent in-car techniques, **smart** road and travel management systems will increase the capacity of roads as well as reduce the number of casualties. Dedicated lanes have been introduced on a wide scale to give priority to certain types of vehicles, e.g. long distance transport lanes (interurban) and separate lanes for buses and bicycles in urban and suburban areas. The road area will

also be used more dynamically. The introduction of variable lane configurations during the day responds to changing demands at different times of day. Finally, to reduce the traffic demand, public transport facilities provide seamless connections to private transport. **Access** to convenient transportation for people of all ages, incomes and physical abilities is the ultimate requirement in responding to the mobility demands of the year 2040.

## 2.2 Concepts and solutions

Based on today's expectations, the vision 2040 reflects society in the year 2040 with the emphasis on the use and perception of road infrastructure. The vision represents the demands and requirements made by society in 2040 on the road infrastructure. Amongst other things, the infrastructure must be reliable and environmentally-friendly in use, durable and sustainable of construction and available and accessible to all categories of users around the clock. Such demands and requirements for the future are ambitious and challenge the sector to fulfil expectations. At the same time, these demands and requirements are important to enable policy makers to make the right choices and decisions today, because the seeds of tomorrow's infrastructure must be sown today.

After presenting the future demands and requirements, the main questions are "How to meet this future" and "How to prepare the sector for solving the complex and challenging questions which will emerge". Comparing the future with the present situation reveals the differences between today's and tomorrow's demands and requirements, but still does not show the steps which have to be taken to bridge these differences. In this context, a long list of demands and requirements, some of which are complementary and contradictory, disrupts a clear and effective discussion. Too many focus points with respect to the future cause confusion and debate. For stimulating, fresh provocative discussions resulting in innovative ideas, the long list of future demands and requirements has been reduced to a selected number of challenging statements. Statements which can easily be remembered by everybody and which at the same time provide food for thought.

The relevant aspect of the vision have been labelled with typical **characteristics** (bold type in the previous section) showing the colour of the demands of the future at a more recognisable level linked to the present jargon of policy makers and engineers concerning road infrastructure. Clustering related characteristics produces this selected number of statements, called new road **construction concepts**

in the context of NR2C, representing and expressing the major users and stakeholders' requirements. The society of 2040 expects:

- **Reliable Infrastructure**, standing for optimising the availability of infrastructure,
- **Green (environmentally-friendly) Infrastructure**, standing for reducing the environmental impact of traffic and infrastructure on the sustainable society,
- **Safe and Smart Infrastructure**, standing for optimising flows of traffic of all categories of road users and safe road construction working,
- **Human (-friendly) Infrastructure**, standing for harmonising infrastructure with the human dimensions.

These four concepts apply to the three fields of the NR2C project: urban and interurban roads and constructions. Society demands reliable, green, human, safe and smart infrastructure in a stable composition. Of course this composition will differ in detail with regard to urban and interurban road infrastructure and structures, but similar basic questions apply to both engineering fields, resulting in a limited number of similar categories of solutions. These solutions are not strictly connected to one of the concepts by definition, but will generally contribute to several concepts. The main subject or aim of a solution or project determines the allocation to one of the concepts, but as a matter of accuracy it is important to take into account the possible benefits for the other concepts as well.

These four construction concepts formed the framework of thinking about technical solutions and research programmes. They have been applied as starting points for debates with scientists, engineers and other stakeholders. By asking questions like: "What are the basic elements of green infrastructure?" and "What needs to be done to create a green infrastructure?" the four concepts have been developed into long lists of ideas and suggestions for projects. Recapitulation of these lists shows similarities and relations between ideas and suggestions, resulting in a selected number of clear and recognisable main solution directions for every concept. Concepts and directions for solutions reflect the main problems facing modern policy makers and help them placing projects and research programmes in the right context.

The transformation of the vision 2040 into new road construction concepts with solution directions has schematised in the figure below. In the next chapters 3 up to 6 concepts and directions for solutions will be explained and developed further.

### From vision to directions for solutions

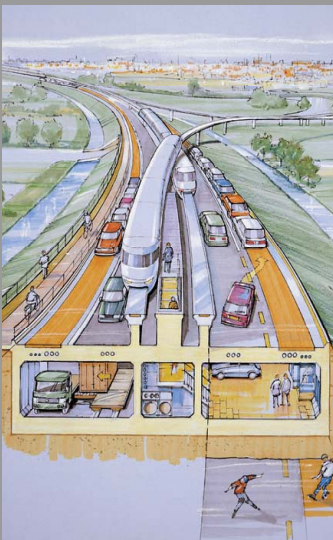
Vision 2040	Characteristics	Construction Concepts	Directions for solutions
	Available Durable Reliable	<b>Reliable Infrastructure</b>	<ul style="list-style-type: none"> <li>• Lifetime engineering</li> <li>• Fast, hindrance-free maintenance</li> <li>• Balancing demand and capacity</li> <li>• Asset management tools</li> </ul>
	Energy efficient Sustainable Environment	<b>Green Infrastructure</b>	<ul style="list-style-type: none"> <li>• Saving natural resources</li> <li>• Emission Control</li> </ul>
	Accessible Smart Safe	<b>Safe &amp; Smart Infrastructure</b>	<ul style="list-style-type: none"> <li>• Safe design</li> <li>• Smart design</li> <li>• Smart communication</li> <li>• Smart monitoring</li> </ul>
	Multi-functional Multi usable Public security	<b>Human Infrastructure</b>	<ul style="list-style-type: none"> <li>• Public security</li> <li>• Multi-functional use</li> <li>• Human design</li> </ul>

### **2.3 Projects and Developments required**

It is common knowledge that the road-engineering sector is known as traditional and conventional. It does not have the appeal of the most sparkling innovative industry. Because of the empirical character of road engineering and the relatively traditional and conventional research and testing equipment available, the process of wide-scale practical implementation of a simple idea into an existing concept or product normally takes several years.

Nevertheless, by means of such incremental upgrades the road-engineering sector has been able to respond to the growing road transport demands over the last decades. Without drastically changing the concepts of design, constructing and the conservative methods of physical/mechanical material testing and research, the sector has managed to improve the performance of road infrastructure and related components. Learning on the job, long-term performance tests in practice and many other forms of comparative empirical research in this period have provided a great deal of knowledge and expertise to answer the questions of today and even many questions of tomorrow. Incremental upgrading through optimising and extrapolating existing traditional concepts produces 'more of the same' solutions and keeps the road engineering sector in a stand still atmosphere.

The complexity of infrastructure works and consequently the complexity of the problems to be solved are increasing. Furthermore, the implementation processes of past years no longer fit the modern slogan of 'time is money'. Because of their technical limitations, existing concepts, common models and testing facilities will no longer be able to generate the right solutions at the right time in the long run. The new generation of problems and demands requires relatively quick, fresh and more sophisticated approaches for finding reliable and adequate answers. And this new generation of questions is already emerging on a daily basis. The sector is already faced with numerous questions requiring a new type of research and more fundamental knowledge of the subject. However, lack of adequate investigation tools makes it difficult to provide acceptable answers and thus hinder trend-setting developments.

This situation sounds familiar to every European country. One way or another, fear of the unknown, the uncertainty of fast results and relatively high initial investments block any serious new developments at national level. In this setting, the motto of 'Wait and see' over rules the diversity of initiatives suggested to push the sector into new challenging and promising directions. Running up against the limitations of existing conventional approaches, the time has come to cross traditional borders and enter a new world with new possibilities. At such times, new sources of more sophisticated and relatively fundamental knowledge must be tapped to offer the market impulses for developing new products, concepts, models and technical tools. In view of the common interest, particularly projects crossing the traditional borders need a European-wide investigation and cooperation impulse.

NR2C stands for 'Let's go and see' instead of 'Wait and see'. Without diminishing the importance of other projects listed, NR2C has selected a number of project calls requiring the special attention of all stakeholders involved. These projects, labelled as 'Developments required', stand out from the other projects because they:

- Cross the traditional borders of common research approaches,
- Incorporate knowledge from other sciences,
- Provoke and challenge engineers to cross the borders of traditional solutions,
- Provide fundamental basic knowledge for break through inventions,
- Are important to all European countries.

For each of the four road construction concepts suggested, a few critical projects are recommended in Chapters 3 to 6 under the denominator 'Developments required'. These projects will provide the sector with new basic knowledge standards for trend-setting developments needed to face the future with confidence.

# 3

## Reliable Infrastructure

### 3.1 Scope of the concept

Roads are the lifeblood of European trade and social utility. Despite the increasing focus on the use of other modalities like railway, shipping and all kinds of public transport, roads carry by far the majority of land freight transport and passenger traffic. Keeping this traffic rolling is the main concern for the road authorities. Building new roads or expanding square metres of asphalt might seem the obvious way to do this. However, the demand for 'traffic space' will always exceed the supply. Congestion-free road transport continues to be an issue but will become an obsession: traffic jams are a fact of life. Above all, the concern extends to conserving the current network and upgrading the existing structures to provide the quality standards of the future: reliable and available around the clock at socially acceptable costs.

#### **Reliable Infrastructure**

*Availability and reliability are the key issues of durable infrastructure, which means high quality and low maintenance of the construction parts of the infrastructure. In the case of maintenance, the impact of these activities on the traffic flow must be minimal. Upgrading this infrastructure is possible without dismantling the existing construction. Reliable infrastructure stands for optimising the availability of infrastructure.*

### 3.2 Directions for solutions

Designing and constructing according to the philosophy of 'Lifetime engineering' affords challenges to road engineers and economic perspectives to road authorities. Lifetime engineering takes into account all transport-related costs by decision-making. The initial costs of structures will no longer be the only dominant factor; maintenance costs including the economic loss of traffic jams due to maintenance work will also play a role. Durable or long life infrastructure with low maintenance is the key to reliable infrastructure in the future. Because of the limitations of current construction materials to bear the increasing traffic loads, new materials and products will have to be developed. A better understanding of the failure mechanisms is an essential stepping-stone for that purpose. Road engineering research must increasingly cross the boundary into the world of physics and chemistry and apply their technologies, such as micron and nano techniques, to discover the phenomena forcing the degradation of construction components. Understanding what is really happening in practice supports the proper design of new products and leads to performance-based testing. On this basis, requirements and contracts that are fully performance-based will be applied in the road construction sector. These enable fast implementation of new products and stimulate innovation in general.

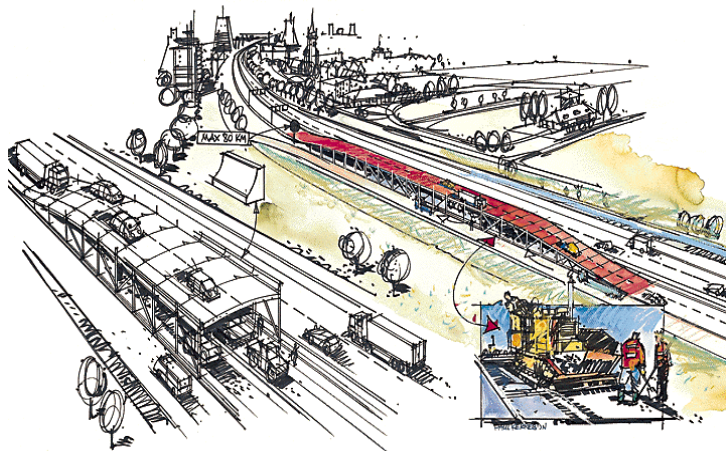

Even the most durable infrastructure cannot escape maintenance from time to time. To minimise the impact on the availability of the infrastructure, **fast, hindrance-free maintenance** techniques must be developed. In fact the foundation of these solutions is laid at the design stage of structures by

remembering that maintenance will be necessary one day. Thinking and designing in terms of building structures from standard prefabricated components and separating long life (bearing) and short lifetime (surface layers) construction parts is one of the first steps. Assembling prefabricated standard modules and components will reduce both the construction phase and the rehabilitation period. In many cases, the degeneration of infrastructures occurs at the surface (loss of stones, skidding, cracking). A new line of surface treatment products must be developed to conserve and revitalise surfaces in the early stages of degradation, thus postponing replacement or more major maintenance work. Preventive spraying with these revitalising products could potentially be a rapid and extremely cost effective method of lifetime extension. Where road or lane closures are inevitable, the use of smart solutions like temporary bridge roofing over the maintenance work is a great step forward. A temporary bridge allows traffic to pass the work site without delay and also reduces the risk to the lives of the maintenance workers.

**Balancing demand and capacity** to optimise the use of the existing infrastructure primarily requires good traffic management. In finding and achieving the right balance between demand and capacity, road-engineering activities are regarded more as an aid or supporter than a dominant partner. Nevertheless many traffic management measurements have an impact on the structural behaviour of infrastructure because of changes in loading. Optimising the availability of the existing networks can be effected by a combination of canalising traffic flows into destination or car category on the one hand and applying a flexible geography of the cross section of the road on the other hand.

The introduction of dedicated lanes, e.g. long distance and short distance traffic (in combination with reduction in the number of entries), good transport, public transport and toll lanes, will improve the availability for the economically crucial categories of transport. Permission to use the hard shoulders

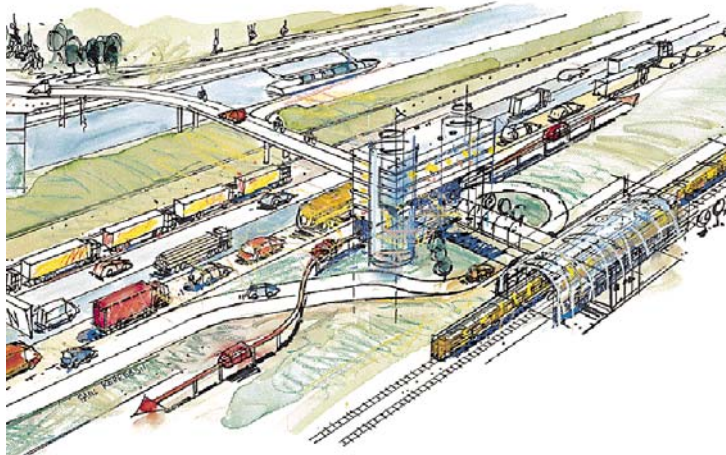

during rush hours creates extra temporary capacity. Nightly time slots for driving road trains over the left lane of highways, for example, create a better balance between demand and capacity during the day. The development of dynamic road markings (switch on or off) offers new perspectives for directing the available capacity according to place and time. Automatic lane changes turning the travel direction, temporarily narrowing the width of lanes (in combination with speed limits) to create an extra lane in cross section become serious options for optimising the road systems.

Besides permanent infrastructure, “infrastructure on demand” can complete the infrastructure of tomorrow if necessary. Floating roads and temporary bridges provide extra capacity on demand in cases of huge manifestations and road closures due to maintenance activities.

The more traffic on the roads, the higher the sensitivity of the road systems to disruption in the traffic flows resulting from accidents and maintenance work. Good **asset management tools** must be developed to support decision-making by road authorities with respect to maintenance strategies and reserving funds for conservation of the road networks. Monitoring systems to quickly establish the condition of the infrastructure, performance models for structures, materials and maintenance techniques to forecast maintenance and in this context determine hard and smart intervention levels for maintenance from the safety point of view become the basic requirements of modern network management.

### 3.3 Projects required

RELIABLE INFRASTRUCTURE	
Directions for solutions	Projects and key issues
<b><i>Lifetime engineering</i></b>	<ul style="list-style-type: none"> <li>• Research performance and failure mechanisms by means of micron and nano technologies in order to develop high performance materials and maintenance technologies.</li> <li>• Achieve high quality performance levels to guarantee around the clock availability e.g. by developing more durable materials to reduce need for maintenance.</li> </ul>
<b><i>Fast hindrance free maintenance</i></b>	<ul style="list-style-type: none"> <li>• Develop modular roads assembled from standard modules (preferably based on European standard dimensions), prefabricated under controlled circumstances, based on the concept of functional separation of long lifetime and short lifetime components, including the whole production chain.</li> <li>• Design constructions and maintenance techniques including materials to minimise the impact of maintenance activities on traffic flows, like               <ul style="list-style-type: none"> <li>○ High speed techniques for replacing thin surface layers;</li> <li>○ Hindrance free maintenance techniques for underground utilities;</li> <li>○ Hindrance free winter maintenance techniques;</li> <li>○ Temporary by-passes (temporary bridges);</li> <li>○ Self-cleaning and regenerating surface layers;</li> <li>○ Sprays to renew or revitalise surface characteristics to postpone major maintenance work.</li> </ul> </li> </ul>
<b><i>Balancing demand and capacity</i></b>	<ul style="list-style-type: none"> <li>• Design infrastructure with options for (temporarily) increasing road network capacity by means of dedicated lanes, temporary bypasses, flexible lane width and lanes with the ability to change travel direction depending on traffic demand.</li> <li>• Accommodate infrastructure requirements and interactions with new transport systems like road trains and Bus Rapid Transit (BRT).</li> </ul>
<b><i>Asset management tools</i></b>	<ul style="list-style-type: none"> <li>• Develop hindrance free self-diagnostic real-time monitoring and inspection techniques in order to optimise maintenance planning and prevent low performance surprises.</li> <li>• Design European-wide standard performance indicators and intervention levels for surface characteristics.</li> <li>• Develop or upgrade in-situ sensors and Specialist Survey Vehicles in order to develop performance models for maintenance management systems.</li> <li>• Develop European quality management systems for construction companies.</li> <li>• Develop knowledge about lifecycles analyses (LCA) and translate this into tools for decision-making.</li> </ul>

### **3.4 Developments required**

#### **3.4.1 NEW AGE BINDER DESIGN (NANO) TECHNOLOGIES**

By means of incremental upgrades, the road-engineering sector has been able to meet the growing road transport demands over the last decades. Without drastically changing the concepts of design and the methods of physical/mechanical material testing, the sector has managed to improve the performance of road constructions and asphalt mixes. Learning on the job, long-term performance tests in practice and many other forms of comparative empirical research in this period have produced a great deal of knowledge and expertise. However availability of knowledge and expertise does not mean that road engineers fully understand the behaviour and performance of the structures and materials they are working with. For instance 'healing, stripping and ageing' of asphalt are well known phenomena affecting the long-term behaviour and performance of pavement constructions. Everybody in the sector also knows that the production and application of asphalt mixtures in combination with the quality of the ingredients of the mixtures and conditions of everyday use affect the extent to which these phenomena appear. But nobody can explain which physical and chemical processes are the actual driving forces of these phenomena. Despite the increased accuracy of measuring deformations and stresses, the current mechanical and physical test equipments, based on beating, pulling pushing and bending specimens, are unable to detect these phenomena either. These tests have been designed for comparative research to separate chaff from wheat and are incapable of predicting the long-term behaviour and performance of pavement materials and mixes.

Better understanding of the behaviour and performance of asphalt layers requires knowledge about the intrinsic properties of the asphalt components, starting with the most dominant and expensive ingredient with respect to lifetime properties: the bitumen or binder. Knowledge about the changes of the intrinsic properties of binders during the entire life cycle of asphalt is essential for managing and controlling the above-mentioned phenomena from the start. For example, which molecules are responsible for the adhesion with aggregates and which for visco-elastic behaviour? The physical and chemical processes during production, processing and use of the asphalt mixtures undoubtedly produce mutations of the molecules inside the bitumen. How and to what extent? Answering these questions will make it possible to create tailor-made bitumen (including bio or agro binders and other substitutes) and asphalt mixtures of higher qualities. To develop this knowledge, the road-engineering sector must cooperate with other disciplines like physics, chemistry and biology and apply their micron and nano research technologies. The potency of these new technologies has been demonstrated in many other sectors. With respect to the building sector, for example, these technologies have contributed to the development of self-healing concrete and coatings. The introduction of these technologies in the road-engineering sector is also strongly recommended by ERTRAC in the Strategic Research Agenda.

The aim of the proposed project is to stimulate and promote the application of micron and nano technologies for research purposes in the road building sector. Experiments must show that these technologies will generate the essential breakthrough knowledge needed to solve today's major problems with respect to behaviour and performance of road and materials. Only by understanding what is really happening in practice, knowing the driving forces of failure mechanisms and knowing which intrinsic parts of the mixing components are responsible for the behaviour of a material or product it is possible to take the right measurements to reduce or prevent failure. For instance which molecules have to be added to a binder to make asphalt better resistant against ageing?

The results of the project offer the industry new challenges to develop high quality materials and proper products. The project will produce a new generation of high added-value competitive products and services with superior performance across a range of applications in the road building sector. Besides the basic quick win of the project will be the cooperation between various disciplines. Consult Annex I for further information about this project.

#### **3.4.2 LIFE TIME ENGINEERING**

A typical problem of high value infrastructure assets is that their relatively long life and the decisions on short-term repairs and maintenance can be contradictory with respect to efficient management in the long term. Short-term thinking with a narrow scope dominates decision-making and blocks insight

into future consequences. The traditional approach to the design and maintenance of infrastructure can be characterised by the following main features:

- the design concentrates on the reaction-resistance (and not the durability) of the structure to the anticipated loads usually just after completion of the facility;
- it primarily considers the construction (initial) costs, is less focused on later maintenance and rehabilitation expenditure and rarely takes into account the future environmental and human aspects throughout its lifetime;
- the design activities approach the whole structure as an entity, do not consider its “modules” separately although their loads, lifetime expectancies and eventual recycling techniques can vary considerably (i.e. no “modular” design is applied);
- designers do not generally cooperate with experts from other sciences (e.g. physicists, chemists, mathematicians, system engineers, etc.) who could make a significant contribution to the complexity and profoundness of the road design.

The traditional approach passes the obvious and worldwide need for sustainable development including sustainable transport. The short-term and too confined design activities and decision-making do not take into account the future consequences, which may be of an economic, environmental, and/or human nature. This attitude must change as quickly as possible into a design methodology which is much more responsible for the next generations. Lifetime engineering offers this possibility although it requires comprehensive research and training of the parties involved. Lifetime engineering takes into account all road transport related aspects by design and decision-making from the use of raw materials to the impact of traffic on the environment. The initial costs of structures and maintenance will no longer be the only dominant factor; maintenance costs including the economic losses caused by congestion due to maintenance work and measures to reduce the environmental immersions throughout the whole life of the road infrastructure will also play a role. Significant economic results can be expected if – following the basic principles of lifetime engineering – the traditional “reaction (resistance) type” pavement design is transformed to “durability type”, meaning that the predicted changing of loads and reactions (strength) of the pavement structure during the entire life is considered, allowing the minimisation of life cycle costs. Consult Annex II for further information about this project.

### **3.4.3 ASSET MANAGEMENT TOOLS**

Road infrastructure is built to satisfy the need for the safe, economic and comfortable transport of goods and people. To fulfil these requirements and services to the users, this infrastructure must meet certain quality standards such as skid resistance, evenness and noise emission. These properties must be created and maintained throughout the whole lifetime of the road. The proprietors of the public infrastructure, represented in most countries by government, provincial and municipal road authorities, are responsible for ensuring the conditions of the road networks. Preservation of the assets value is among the main tasks of these central, regional and municipal institutions.

Besides the preservation of existing networks, these institutions are facing growing demands from society concerning the service level of the networks: undisturbed traffic flows with minimum impact on the environment. However, as the result of ever-higher living standards, the number of road vehicles and subsequent traffic volume and axle loads are constantly growing. The more traffic on the roads, the more deterioration of the infrastructure components, but also the higher the sensitivity of the road systems to disruption in the traffic flows resulting from maintenance work and accidents. Furthermore, this rise in the amount of traffic produces a correspondingly negative impact on the environment in the form of air pollution and noise emissions affecting the health and quality of life of substantial numbers of people living alongside the road networks.

In general, the available financial resources are far from the justified needs, which are also partly contradictory. The task of the road authorities is to find the right balance between preserving or rehabilitating the existing networks and implementing new demands or requirements. A coordinated asset management system could make a significant contribution in this. Management tools must be developed to support decision-making by road authorities with respect to maintenance strategies and reserving funds for preserving and rehabilitating the road networks.

In many European countries, the expansion of the existing infrastructure dates back to the 1970s and 1980s and are thus reaching the end of the serviceability. Knowledge about their condition is therefore essential for planning the expenses involved in maintenance and rehabilitation over a period of at least ten years. Such planning requires the development of monitoring systems to quickly establish the condition of the infrastructure, performance models for structures, materials and maintenance techniques to forecast the maintenance required year by year. These developments must be accompanied by research to fund and qualify the various service levels operational today: which intervention levels for maintenance work must be qualified as 'hard' (essential) and 'smart' (less important) in terms of safety and the environment, for example. These proposed tools form the basic stepping-stones of modern network management. Consult Annex III for further information about this project.

#### **3.4.4 MODULAR PREFABRICATED PAVEMENTS**

The traditional method of constructing a road surface has gradually acquired an amorphous mixture of qualities that must fulfil a whole range of functions. Over the decades, the hot-rolled asphalt superstructure evolved from providing a comfort layer to being a bearing construction, comfort layer, texture/skid resistance layer, water drainage layer and noise reducing layer in one. This traditional building concept is less flexible in design, construction and maintenance. The functional requirements will vary according to place and time. For example, a silent road is more preferable in some places and at some times than others. For (heavy) goods transport, heavy vehicle traffic makes other demands on comfort and supporting power than private cars. By unravelling the functions and developing specific components or modules for each function, a 'made-to-measure' road surface can be created by stacking the right layers on top of each other, provided that it is easy to exchange the modules. The functional approach behind this concept promotes the use of the right materials for the special requirements of specific components and distinguishes between long lifetime components (low maintenance frequency) and short lifetime components (fast maintenance). The concept of modular building also offers possibilities for the indoor manufacture of components under controlled production conditions, which provide high quality and accelerated introduction of new materials. The assembly of these prefabricated components on site will be less dependent on weather conditions and thus be faster and more flexible than the traditional construction method. Furthermore, prefabrication lends itself very well to incorporating smart devices, such as monitoring the performance of road components.

The constant increase in the number of road vehicles consequently means, a continuous rise in traffic volumes and axle loads, accelerating developments like congestion, wear and tear of structures and last but not least air pollution and noise emissions. Decisions about expanding the road network taken yesterday should preferably be achieved tomorrow. To minimise downtime of roads for maintenance, the overall quality of the structures must be upgraded. The time slots available for repair and rehabilitation work become closer and closer, requiring faster maintenance techniques. The more traffic, the higher the quality standards required, but also the less construction and maintenance time available and the greater the demand for modular prefabricated structures.

New design concepts, new construction and maintenance techniques for pavements based on the assembly of prefabricated modules will be the main result of the proposed project. This new approach to building road pavements will challenge the industry to develop new materials and components whose properties better correspond with the functional specifications. The final objective will be better, faster and cheaper construction and maintenance of pavements through further cost-effective industrialisation of road building processes. Consult Annex IV for further information about this project.

# 4

## Green Infrastructure

### 4.1 Scope of the concept

As rivers and mountains naturally reclaim the geographical composition of continents, so ground transportation systems dominate the physical planning of landscapes and cities. These man-made systems/barriers offer freedom of movement to people and goods in society on the one hand, while having almost irreversible consequences for communities and natural habitats along roads and railways on the other hand. The freedom to transport goods and people, generate economic prosperity and improve our standard of life is increasingly in conflict with the social well being of the direct neighbours of the transport systems, especially in the densely populated urban and suburban areas. The social demand for cleaner, quieter and more energy-efficient road transport with minimum impact on communities and natural habitats, poses the challenge of closing the gap between these conflicting needs to all industries involved with road transport. By means of design, construction and use of materials, road-engineering sectors can contribute to environmentally friendly (green) infrastructure.

#### **Green (environmentally friendly) Infrastructure**

*Minimising environmental impacts on communities and natural habitats are the main issues of this concept. Green infrastructure fits into its surroundings and contributes by means of design and composition to minimising the impact of traffic (noise, air pollution and vibrations) and energy consumption of the transport system. It also optimises the use of non-traditional materials for road building and reduces the use of natural resources. Green infrastructure stands for reducing the environmental impact of traffic and infrastructure on the sustainable society.*

### 4.2 Directions for solutions

Better integration of infrastructure in its surroundings is rather a matter of willingness to give natural habitats a chance to survive than a lack of road engineering solutions. Proper design and modelling of the verges and the creation of barrier-free ecological areas using eco ducts are examples of ecological engineering that can already be found in some European countries. Local circumstances and demands will ultimately determine the best solutions. As a major consumer of building materials, an



important contribution of road engineering to the green infrastructure concept involves the **saving of natural resources**. Road construction annexes land or scarce public space to urban areas and affects the landscape elsewhere for the supply of first class building materials. Furthermore, maintenance and reconstruction works generate a huge amount of building rubble that is transported to landfills, which also affect the landscape. The complete recycling and reuse of this building rubble will be the first challenge facing road engineers in the near future. Upgrading building rubble generated by sanitation of commercial buildings and houses and other industrial waste products to proper road building materials is the second step. The line of saving natural resources must be

extended to saving energy. The handling of thousands of tons of building materials is a very energy consuming business for road constructing. Nevertheless important savings can be made by focusing more on the treatment of these materials on site and in plants. Hot asphalt mixes are the main

components of pavement constructions. The development of high quality low temperature binders and mixes produces substantial savings in energy and production costs. In this context and also in view of

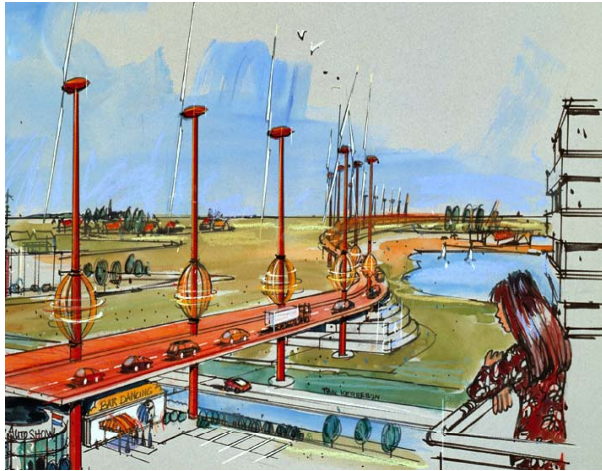

the increasing scarcity and expense of natural oil, the development of so-called Bio-binders will be a serious option. Recovery of energy from pavements, continuous heated up by solar radiation, becomes attractive in spite of the growing need of sustainable energy sources. Saving natural resources through developments in road construction covers just one area. The vertical (gradient of abutments) and horizontal (curves) alignment of road design and the condition of the road surface (texture, evenness) particularly affect the rolling resistance of trucks and thus fuel consumption (and air pollution). Rough and uneven road surfaces will increase this consumption. Research is required to quantify and model the effects of these tyre/road

interactions in order to develop cost effective and safe solutions.

Nobody can blame the road authorities for people wanting to use their networks for transporting persons, goods and themselves. Without measures, the popularity of road transport tends to founder because of its own success. The tremendous rise in the amount of traffic over the last two decades has produced a corresponding negative impact on the environment. Air pollution and noise emission continue to affect the health and quality of life of substantial numbers of people. Furthermore, energy consumption in the sector is contributing to the global Green House Gas emissions. Developments of low emission (combustion) engines and restricted car-use must significantly reduce this in the next decades. In the meantime, reduced to the dominator '**Emission control**', road authorities have been invited to produce innovative solutions to reduce the impact of emissions. With respect to silent pavements, progress can be made by means of fine-tuning the mix design and application techniques. Prefabrication of thin noise absorbing surface layers on the roll under controlled circumstances will promote this development. Materials capable of absorbing noise and possibly air polluting components must be developed to reduce the impact of emissions under legal standards. To prevent exhaust (blacks) and non-exhaust (brake wear, tyre wear, etc.) particulate matter emissions blown up by wind and passing traffic, cleaning systems must be designed to remove these pollutions from urban and suburban areas. In the case of extreme polluting situations and where it is impossible to abandon polluting cars, covered roads in combination with air-cleaning systems are an option.

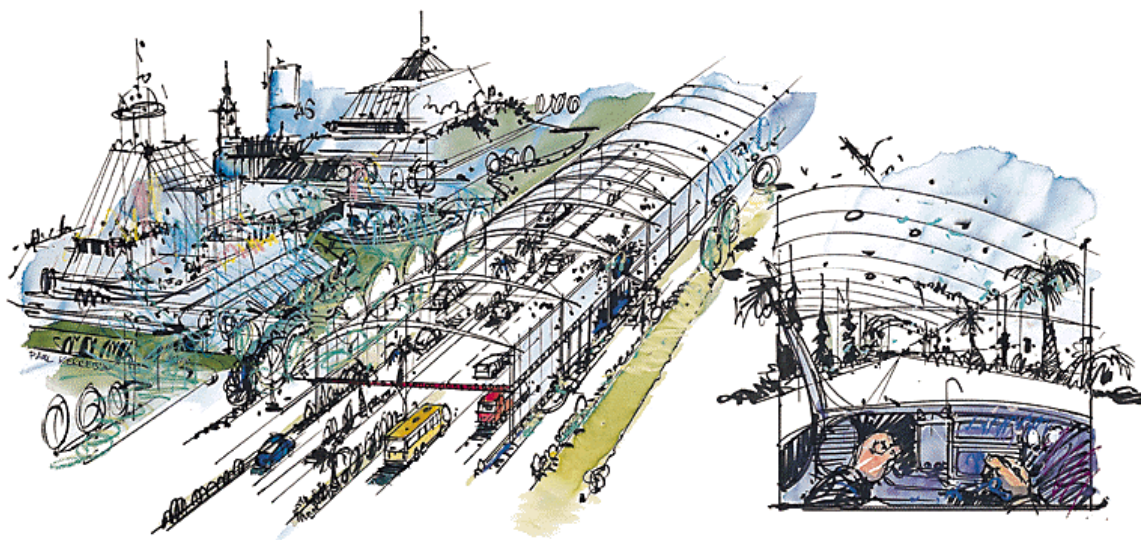

### 4.3 Projects required

GREEN INFRASTRUCTURE	
<b>Directions for solutions</b>	<b>Projects and key issues</b>
<b><i>Saving natural resources</i></b>	<ul style="list-style-type: none"> <li>• Develop tools to assess environmental impact in a global approach (from materials to structure) as a component of life cycle analyses.</li> <li>• Develop new techniques and management tools to support and optimise the reuse and recycling of building materials and other non-traditional materials (for example in-situ recycling processes).</li> <li>• Develop low energy consuming construction and maintenance techniques, like prefabrication and low temperature asphalt</li> <li>• Quantify the effects of the road condition and road alignment on the fuel consumption in order to optimise the tyre/road interactions (rolling resistance).</li> <li>• Design (aesthetical) infrastructure that fits into its environment and reduces the impact on flora and fauna and restore habitat fragmentation (eco viaducts).</li> <li>• Develop and introduce new environmentally-friendly and sustainable building materials for pavement constructions (bio-bitumen) and structures (bio-plastics)</li> <li>• Design systems to recover sustainable energy from road infrastructure (solar, wind, braking vehicles, hot-water collectors)</li> </ul>
<b><i>Emission Control</i></b>	<ul style="list-style-type: none"> <li>• Design urban infrastructure that will reduce the impact of traffic (noise, pollution and vibration).</li> <li>• Develop systems to reduce the generation and dispersal of chemical pollution in road, run off, vehicle spray, winter maintenance and accident spillages.</li> <li>• Develop concepts for roads that reduce the creation of particulate and other pollutants (through tyre wear, brake wear, road surface wear) and in situ cleansing methods</li> </ul>

### 4.4 Developments required

#### 4.4.1 LOW TEMPERATURE ASPHALT WITH RECLAIMED ASPHALT

In Europe, 320 million tons of asphalt are produced every year for the construction of roads (source: European Asphalt Pavement Association – 2005). Asphalt is produced at high temperatures (160 – 180°C). An average energy of 275 MJoule is needed per ton asphalt, resulting in an energy consumption of 88 billion MJoule for Europe. Asphalt production is therefore a highly energy consuming industry and results in high CO<sub>2</sub> emissions. In the context of the Kyoto agreement, energy reductions and reductions of CO<sub>2</sub> emissions in production processes are high priority.

In recent years several techniques have become available to produce asphalt at reduced temperatures and field trials are being conducted in several countries. The reduction in temperature that can be achieved depends on the technique used: reductions of 30°C to 60°C are technically possible. The results look promising, but there are still many unsolved questions and challenges. In particular, a crucial point for general acceptance of these techniques by the road authorities is the proof of equivalent performance as hot mix produced mixtures and the possibility of applying these techniques in combination with reuse of old asphalt. As asphalt recycling in asphalt production is very important and common in many countries, it is crucial that these techniques can be combined with

high percentages of reuse materials, otherwise the general use of these new techniques will be difficult to accept. Besides the reuse of reclaimed asphalt is interesting from the financial point of view, because the prices of waste deposits have become very high in many countries.

Research will be performed in the laboratory and on the field. In the laboratory, the necessary know-how will be developed for the type testing (mix design and testing) of these mixes with the required workability, compactibility and performance. This laboratory experience will be up-scaled to large-scale production and field implementations to demonstrate that real production and laying is adequate and gives the required performance.

More particularly, the following results are expected:

- recommendations for the design of asphalt mixes including feasible percentages of reclaimed asphalt to be applied,
- performance of different low temperature production techniques including the performance of the final products in relation to traditional hot mix asphalt,
- recommendations concerning production, laying and compaction
- environmental and cost analysis

Consult Annex V for further information about this project.

#### **4.4.2 BRIDGE ECO-ASSESSMENT**

In the past, the key word for bridge designing was "resistance". In recent years, in addition to resistance, the introduction of durability concerns has been at the source of an initial important change and a renewed approach to bridge design, from the choice of materials to the choice of the type of structures and detailing. Nowadays, it is clear that sustainability is our newest major challenge! Preserving the environment, saving rare materials, reducing energy consumption are the new targets. Representing 46% of energy consumption and 25% of greenhouse gases, the construction sector has a major role to play. All the actors concerned (material and product suppliers, construction companies, decision makers, bridge owners,) are very aware of this fact. Each of them agrees that sustainable development requires innovation in civil engineering and they are ready to make the necessary changes. Material suppliers for example have already put a great deal of effort into reducing the environmental impact and energy consumption of their activities. The concrete and steel sectors have already launched some environmental assessment approaches for various industrialised products to be integrated in constructions.

To be able to move from the level of materials or individual products to a complete structure, taking into account its whole life cycle from erection, and service to dismantling, recycling and ultimately end of life, we need tools and agreed methodologies that will enable us to assess bridges on their whole life from an environmental point of view. Such tools are now being developed and applied for road environmental impact assessment, generally based on life cycle analysis and multi-criteria analysis. With regard to buildings, there is also the HEQ (High Environmental Quality) approach which still has to be transferred to civil engineering. To accelerate this transfer, it is necessary to:

- Demonstrate the feasibility of the sustainable approach for each bridge family (concrete, steel,) by making an environmental assessment of various typical solutions of current bridges in Europe and thus identify sources of progress inside each family. Current bridges must be studied because they represent 90% of the total number of bridges and consequently a major environmental and economical weight.
- To develop some improved environmental solutions that would also be economically assessed, and to check they remain globally competitive.

This approach taking into account environmental criteria will also enable the practical implementation of some very innovative solutions, which are still not currently competitive, if only considering usual costs.

Eco-assessment of bridges complies with sustainable requirements for the benefit of society and is a vehicle of innovation, development and competitiveness for the European civil engineering sector. Consult Annex VI for further information about this project.

# 5

## Safe and Smart Infrastructure

### 5.1 Scope of the concept

Despite significant improvements over many years, the number of (fatal) injuries resulting from road accidents remains high. The target set by the European Countries of a 50% reduction in road deaths by 2010 is indeed very ambitious, but it does emphasise the gravity of the situation. An accident is seldom a stand-alone event, but the ultimate consequence of a number of non-expected incidents and factors, such as weather conditions, disorderly traffic flows, road design, road condition, attentiveness, awareness and accuracy of the road users. Clearing up incidents and interfering in one or more leading factors will certainly help reduce the number of casualties. In this framework, important questions are: "Who is responsible for what" and "Who is taking the lead". Is it the commercially driven automotive industry or the low-budget road authority? The automotive industry has started to recognise the importance and potential of putting more electronic intelligence into its cars (like lane and distance-keeping systems). Vehicles are becoming smarter and smarter year by year and their intelligence focuses on the additional comfort and safety of the individual driver and his passengers, the "user's optimum". However, road network managers or road authorities are interested in the overall safety and unrolling of traffic on their networks, the "system's optimum": homogeneous traffic flows with controlled speed limits improve the traffic performance of roads as well as safety. Achieving 'system's optimum' means more than adding up the optimum travel time of individual cars. To achieve the system's optimum, it may be advisable to exclude freight traffic from using some lanes of the road over a certain period in favour of other drivers. Traffic managers can only take such a decision at central level. An explicit requirement for achieving the system's optimum is the availability of information about the use and condition of the road network at any time. To gather this information some intelligence has to be 'in-built' into the road infrastructure. To support the traffic managers, smart infrastructure, i.e. infrastructure that is capable of observing, interpreting, deciding and acting, will be necessary.

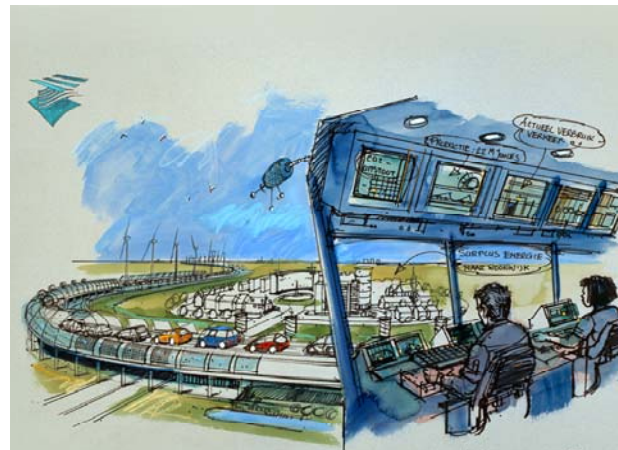

#### **Safe and Smart Infrastructure**

*Smart and safe infrastructure observes (traffic flow, circumstances and itself), interprets, decides and acts to promote safe and comfortable travel and help the owner of the roads keep the infrastructure objects in safe condition. Safe infrastructure stands for optimising flows of traffic of all categories of road users and road construction work safely.*

### 5.2 Directions for solutions

The basic requirements of safe and smart infrastructure are naturally the quality of the hardware or the physical infrastructure. It is for the road engineers to design and construct infrastructure that inspires confidence in all road users with respect to safety under normal conditions, day and night. A **safe design** is the elementary basis. Discussions about ground transportation are always dominated by car drivers, but motorbike riders, cyclists and pedestrians also want to survive their journeys on public roads. It cannot be denied that most fatal accidents occur in the countryside and in urban and



suburban areas. Confusing intersections, lack of an overall view in bends, hard obstacles (trees, barriers) in verges that are too close to the roadway and the diversity of road users in the same place are some of the main reasons. Offering road users a clear and proper design is an important step to safety, as it enables them to recognise and assess the local situation. In this context, research resulting in Guidelines for Safe Design will be a valuable investment. Safe design also includes the use of proper building materials, guaranteeing the comfort and safety of road constructions. Road users have to rely on the expertise of the road engineers in choosing the right materials and on the interest of road

authorities in maintaining the safety of the infrastructure. Without preventive warning signals, road users may expect the relevant performance indicators of surface layers such as evenness, skidding resistance and rutting to comply with standard safety levels under all kinds of weather conditions.

The general need to optimise the road systems in order to improve safety and capacity initially requires the systems to have the capacity to manage traffic. On a network, which increasingly resembles a slow moving car park for most of the day, good advice is wasted. Directing car drivers from one traffic jam into another does not justify the high investment costs. System optimisation demands **smart design** of the road networks involved. Here smart design stands for creating a 'playground' with enough free space and sufficient freedom of action to solve congestion caused by high traffic demand or incidents. System optimisation means being able to choose alternatives.



Besides expanding the road network, creating temporary capacity inside and/or outside the network is the most obvious solution. Therefore smooth connections and bypasses between the different networks are the first requisites. A rather simple way of achieving extra capacity on the highway system is to allow the use of hard shoulders during rush hours and in the case of accidents. The development of dynamic road markings makes it possible to optimise the use of the existing square metres of roadways. By narrowing the lane width (in combination with speed limitation), an extra lane can be created in cross section. At all network levels, dynamic road markings bring automatic changes of travel

direction in reach. Less popular but effective is the creation of buffer zones holding cars near the access to a network. Restricted access (car by car) from these zones prevents overcapacity on a congested road section. It is the choice between every car standing still or the majority proceeding on their journey. All these examples of measurements aimed at optimising the use of the existing roads directly or indirectly affect the behaviour of the road infrastructure. Changes of loading the pavement construction affect the performance.

A smart road observes, interprets, decides and acts. With respect to supporting drivers, the latter function requires proper communication of decisions to road users. An exponent of smart design is **smart communication**: the way of communicating relevant information to the road users. They must be able to understand what the "system" or traffic manager means because they only have a few seconds to reflect and react. Communication between the smart road systems and the cars will be crucial to the success of system optimisation. A realistic estimation will conclude that automatic vehicle guidance will be achieved by the year 2040. In the meantime, communication will focus on dashboard displays and warning signals in cars and a range of traffic signs and information panels above and alongside the road. Road users are already overwhelmed by information, sometimes relevant but

often irrelevant. (What are the limits: the human brain or the available space in the verges?) However, the relevance of information changes according to the time. Research is required to develop real Dynamic Road Information Panels with the ability to integrate common traffic signs, static and real-time information so that the right information can be shown at the right time. This reduces the number of signs and other information panels alongside the road and focuses the attention of the road users on one spot. Remember that not everyone travelling in the morning rush hour is looking for a hotel or museum. A real challenge will be the development of road surface layers changing colour when the service level, for instance skidding resistance, falls below the standard safety level.

Over the past few years, many applications of Intelligent Traffic Systems have been developed and tested on a modest scale in local areas. These first generation systems rely on indicators that are used to manage traffic flows. Most studies and research point out that the weakness of such applications is the poor quantity and quality of real time data available for input. Easy and cheap data acquisition will be the critical success factor of ITS which requires the development of **smart monitoring** devices. It is no secret that road authorities are not very keen on the presence of sensors in their pavement constructions, except those that are necessary for their own asset management.



Traffic disturbance, caused by the implementation of in-situ sensors and their maintenance costs temper enthusiasm to install more than strictly necessary. In this respect, in-vehicle sensors are preferable. The current low “density” in-situ sensors (Weight In Motions systems, strain gauges, traffic and speed counting loops, etc) in combination with specialist survey vehicles generate data for modelling structural deterioration of roads and bridges and modelling traffic flows. This is then used for asset management models at network level. To improve the management of maintenance at road section level and to bring impending problems to the attention of road operators before significant

deterioration occurs, sensors must be developed. Fitted to standard vehicles (“probe vehicles”) these sensors can provide up-to date information about the road condition and surface characteristics of the pavements. Probe vehicle and in-situ measurements will together provide the data needed to achieve “system optimum” and enable road authorities/operators to maintain the networks to the high levels of comfort and safety expected by the road users.

**5.3 Projects required**

SAFE AND SMART INFRASTRUCTURE	
<p><b>Directions for solutions</b></p> <p><i>Safe design</i></p>	<p><b>Projects and key issues</b></p> <ul style="list-style-type: none"> <li>• Improve Guidelines for safe design, including basic standard design rules guaranteeing safe, comfortable and recognisable infrastructure (alignment, pavement, crossings, junctions connecting different networks and ‘special structures) at any moment of the day in order to minimise errors of road users.</li> <li>• Develop and use proper and durable building materials and construction components with low (quick and hindrance free) maintenance demands guaranteeing a high basic safety performance.</li> <li>• Design constructions and maintenance technologies to minimise the impact of maintenance activities on traffic flows.</li> </ul>

SAFE AND SMART INFRASTRUCTURE (continue)	
	<ul style="list-style-type: none"> <li>• Develop and dictate new materials and construction parts that support a higher degree of safety for the road users, like               <ul style="list-style-type: none"> <li>○ Light reflecting surfaces (safer during the night);</li> <li>○ Heat absorbing surfaces in order to use infra-red scanning (better visibility at night and in case of fog);</li> <li>○ Coloured surfaces to support safe virtual lanes for cyclists;</li> <li>○ Human friendly safety barriers to 'protect' motor bikers;</li> <li>○ Soft curbing to protect pedestrians and cyclist for head injuries;</li> <li>○ Braille type marks for safe guidance for the blind.</li> </ul> </li> </ul>
<b>Smart design</b>	<ul style="list-style-type: none"> <li>• Develop smart detecting and warning systems to inform road users in case of unsafe performance of surface layers (for example low skidding resistance of icy roads)</li> <li>• Develop ICT systems to support the design of infrastructure with the potential of (temporarily) increasing road network capacity by means of dedicated lanes, temporary by-passes, flexible lane width and lanes with the ability to change travel direction depending on traffic demand (dynamic road marking, intelligent merging supporting systems).</li> </ul>
<b>Smart communication</b>	<ul style="list-style-type: none"> <li>• Research on Automatic Vehicle Guidance (AVG) and its integration into existing road infrastructure.</li> <li>• Install self-diagnosis systems, sensors and actuators for the active control of structure vibration.</li> <li>• Develop all-round Dynamic Road Information Panels aimed at optimising communication with the road user by presenting the right type of information at the right time and reducing the confusion of existing traffic signs and panels above and alongside the road.</li> </ul>
<b>Smart monitoring</b>	<ul style="list-style-type: none"> <li>• Design multi-functional in-situ and in-vehicle monitoring and detecting systems generating real-time data to inform the road users about safety and routing, the police about speeding, security and axle loads, the traffic manager about incidents, traffic flows and free capacity and the road operator about road and structure condition.</li> <li>• Research the effects of in-situ sensors and other smart in-situ components on the overall performance of pavement structures and on maintenance techniques and management.</li> <li>• In cooperation with the automotive industry, develop in-vehicle sensors which are able to detect the real-time condition of the road structures.</li> </ul>

## 5.4 Developments required

### 5.4.1 TYROSAFE: OPTIMISING TYRE-ROAD INTERACTION

Drivers need grip between the tyres and the road to accelerate, decelerate or change the direction of a moving road vehicle. This grip is provided by the skid resistance properties of the road surface in combination with the friction characteristics of the tyre. This combination is critical for safe driving and many European countries have investigated the correlation of a low skid resistance level with accident

hot spots. The result of this research proves that with a sufficiently high value of skid resistance, the safety of roads can be improved and the number of accidents reduced. Skid resistance is therefore a very important characteristic of the road surface affecting safety particularly because it can be improved by the design of the road surfacing.

However, although improving the tyre-road interaction to increase skid resistance has positive effects of improving safety, there may be negative effects such as increased rolling resistance and noise emissions. A higher rolling resistance means the use of extra energy to overcome this effect, which could lead to higher fuel consumption and CO<sub>2</sub> emissions. In these times when environmental issues like noise, air quality and consumption of energy are becoming increasingly important, any consideration of the safety benefits of improved skid resistance therefore needs to focus on rolling resistance and noise emissions as well.

Currently the properties of road surfaces and tyres are not optimised to balance all of these effects. Rather, road engineers or tyre manufacturers concentrate on one or two separate aspects. Knowledge of how these effects interact with each other is very limited. Therefore, optimisation of tyres or road surfaces for one main effect could lead to negative impacts on the other properties.

To be able to assess these interdependencies it is necessary to measure the respective values for skid resistance, rolling resistance and noise emission. To accomplish this task, especially for skid resistance and noise, most European countries have developed their own measuring methods. To ensure the comparability of measurement results, a common basis must be created to which the different techniques can refer. In this context, the policies and standards of individual countries relating to skid resistance, rolling resistance and noise emissions vary considerably across the EU.

The same is true of the impact of climatic change, since current standards are based on historic responses to national requirements and climatic conditions. The potential effects of climate change, however, could mean that the assumptions on which these standards are based will change. Other measures needed to manage the effects of climate change may also have side effects on the characteristics of road surfaces and the skid resistance that they can provide.

Many of these issues have already been addressed and different EU countries have carried out research separately, but there is a need to bring ideas together and establish what scope there is for developing a harmonised approach for the future. This is necessary to ensure increasing safety and greening of transport on European roads and not just at national level.

This Coordinating Action will not only focus on the road surface but also on tyres and on the interaction between the road surface and tyres. Only an optimised interaction can lead to a high level of safety for drivers on the roads in European countries while ensuring the most positive greening effect, through reduction of CO<sub>2</sub> output and noise emissions.

This project will provide a synopsis of the current state of scientific understanding and its current application in national and European standards. It will identify the needs for future research and propose a way forward in the context of the future objectives of European road administrations in order to optimise three key properties of European roads: skid resistance, rolling resistance and tyre/road noise emission. Consult Annex VII for further information about this project.

#### **5.4.2 ENERGY CONTROLLED PAVEMENTS**

The fact is that roads and pavement constructions have to perform literally in the open air. Consequently these constructions are exposed to a range of weather conditions leading to a variety of thermal conditions for the road structure and hence to a variety of conditions for the road drivers.

- In summer, the structures are permanently collecting heat from solar radiation which makes asphalt pavements particularly susceptible to permanent deformations, producing rutting at the road surface. Rutting affects the safety level of the pavements, specifically in case of rainfall when aquaplaning causes cars to lose control.
- In winter, the water penetrated into the road surface layer will become frosted coupled with volume expansion deteriorating this pavement layer (pot-holes, stripping). The combination of low surface temperatures and cooling down of the air with a high relative humidity will cause white frost and icy road surfaces, affecting the safety of drivers. De-icing products (mostly salts on roads and liquids on airfields) must be used to keep the roads free of ice. However

these products have many disadvantages for the environment: contamination of the verges and ditches alongside the road.

- The temperature differences between summer and winter, but also between night and day cause expansion and contraction of the road materials. The subsequent stresses and strains affect the lifetime of the pavement and produce road cracking.

These temperature changes between air and structures take place in a completely uncontrolled way and surprise road authorities again and again. A better control of the thermal condition on pavements will increase the safety, reliability and sustainability of the road networks.

Another observation is the increasing energy demand of the road infrastructure for all kind of facilities to support the traffic flows, such as lighting, traffic control systems, intelligent road markings and various communication services (telephones, road sensors, information panels and infrastructure-driver communication). On the other hand, most countries have millions of square meters of pavements in which heat is permanently collected by solar radiation - free energy that slips away because of uncontrolled exchange with the environment through air and soil. For the next decades the challenge will be to recover this thermal energy to supply road and traffic-related facilities with energy and to control the thermal energy of road pavements at the same time.

Comprehensive experiments with energy controlling systems and recovery systems have been conducted in some countries over the past few years. These experiments, assembled with commonly available components and techniques, have produced various results but have also demonstrated that energy recovery by controlling the thermal conditions of pavements has potential and is more than a scientist's dream. Optimising available components and even developing new materials and techniques requires a research impulse to achieve successful and cost effective solutions. Combination with prefabrication of road components will increase the chance of successful results.

The project will have the character of fundamental research and requires cooperation with other sciences. The research will start by reviewing all the possible physical and chemical synthesis and techniques. Laboratory tests will establish the effectiveness of potentially suitable techniques and products. Really suitable product and techniques will be demonstrated in field tests in order to show that energy recovery from pavements can become reality, thus stimulating stakeholders to produce innovations. Consult Annex VIII for further information about this project.

# 6

## Human Infrastructure

### 6.1 Scope of the concept

Europe is the most urbanised continent in the world, with 80% of its population living in towns and cities. Due to the growing population and continuing industrialisation near towns and cities, an explosive urbanisation has taken place over the last fifty years. Towns have evolved into cities; cities have become metropolises swallowing local communities one by one. Such urbanisation and sub urbanisation reached its peak in the 1960s and 1970s, accompanied by poor quality town planning. Town planning was characterised by monotonous apartment buildings lacking any aesthetic design, built as closely together as possible. Accommodating people like cattle seemed to be more relevant than creating social and liveable communities. Of course, developments in the field of mobility systems and specifically those in the automotive industry have strongly supported this continued process of urbanisation. The location of business parks, shopping centres and new housing estates no longer



matters. By car, everything is within reach. The huge rise in the number of vehicles and car use is now a scourge on city life. The omnipresent vehicles dominate the configuration of scarce public space in towns and cities. Streets were rearranged to become roads, roads became carriageways and carriageways became super highways to keep road traffic running and feed the conurbations with goods and people. As a result, other socially relevant functions of the public space have been pushed aside, both literally and figuratively. At the end of the fifty-year period of the reconstruction of Europe, the slogan is 'more is beautiful'. Great, greater, greatest or big, bigger, biggest and fast, faster, fastest dominate our way of thinking. It seems as

if policy makers and town planners have tried to project and copy the American dream and Tokyo's city maps in the main cities of Europe. However they have forgotten the difference in culture between Europe and the other continents. European economic spaces today are huge crowded organisms, continuously evolving and linked by congested streets, roads and railways in a polluted environment. This is not the quality of life that society is looking for in the near future. The time has come for a revolutionary change in the configuration of public spaces in order to facilitate other socially relevant functions and reduce the impact of road transport on people's health and lifestyles.

### Human Infrastructure

*The main characteristics of this concept are multi-functionality and multi-use of the space occupied by infrastructure. Human infrastructure offers the main categories of road user the elementary facilities which guarantee social security. The main points are sharing the space with non-road users for leisure, etc. and exploring the space above and below the road surface to facilitate other socially relevant functions (transport and non transport-related). Human infrastructure stands for harmonising infrastructure with the human dimensions.*

### 6.2 Directions for solutions

The built environment shapes our society, our way of life, our work, our leisure, our mobility. In order to develop a sustainable built environment for all, we must have a society based on equal rights and opportunities. Many people in today's society depend on an accessible environment in order to live autonomous and active social and economic lives. Providing **public security** in public spaces will

probably be most instrumental in persuading citizens and other potential road users to use the available infrastructure facilities. Special attention and care must be paid to the most vulnerable users of roads and public spaces: pedestrians, cyclists, people with disabilities, people with reduced mobility, old people and children. In general, well-designed and recognisable configurations of public spaces will inspire confidence in public security. Besides separating the vulnerable road users from motorists, a clear and open design will promote a sense of well-being. Users must be able to keep an eye on each other at any time. Prevent the creation of black spots such as subways for the sake of vulnerable road users. Outside rush hours, these tunnels are not considered safe and are therefore not used because of the lack of social control. The best place for the more vulnerable category of users is ground level in the open air. In a certain sense the general behaviour of the various categories of road user affects well-being. Developing a means of guiding and controlling the behaviour of all categories of road users supports the public security component as well as the safety component in the use of public spaces. The demand for public security is even more prominent when it gets dark. In rural areas, in emergency places and service areas alongside interurban road networks, more focus on public security needs is required during the period of darkness. Given the importance of visibility and surveyability, these areas must have a clear and open design with good lighting to offer users a satisfactory level of security. In this context, the development of intelligent lighting systems, such as infrared systems, which switch on the lighting when they sense people, should be promoted.

Although visibility and surveyability are the most important aspects, other human senses also play a role in our perception of public security. A barrage of noise and polluted air outside our doors holds no prospect of an enjoyable sortie into public spaces. Developments in design and configuration are required to reduce the negative impacts of traffic.

Citizens want their streets back to upgrade their social activities in their living surroundings. They are tired of their living space being invaded by polluting cars and trucks speeding by. On the other hand, they expect facilities and services to meet their daily needs. All these needs must be satisfied by one and the same area of public space, which will be nearly impossible to attain without relinquishing some demands. Designing a configuration for public space that allows a **multi-functional use** of the available area at different times of the day could be an option. For example, the use of public transport (tram and bus) lanes for transporting and delivering goods in the late evening or even modelling parking areas so that they can be used as a children's play area during the day or at weekends. However, many of today's cities do not even have these opportunities. They cannot incorporate modern services unless they sacrifice or destroy the scarce public and inherited historical spaces, environmental culture and ambiance which have served as a cultural reference from one generation to another. The last remaining option is to conquer the third dimension. The steadily increasing market value of land in the cities is another important reason for going underground, where the space is still vastly underused compared with land above ground. This ultimate design solution for the multi-functional use of public space offers opportunities to transform the congested, noisy and polluted urban environment into pleasant living areas and to improve the quality of life for city dwellers. Moving the noisy and polluting traffic transport facilities and parking areas underground will create new empty spaces at ground level for the enjoyment of the citizens. An alternative building concept might be to create an artificial ground level by covering in the original surface level including the road transport facilities. This building concept, recommended for developing new housing estates and business parks, creates similar benefits as underground building: clean, secure, safe and comfortable public space.



The traditional model of extending offices, housing and road transport facilities is to develop cities vertically and horizontally. Higher buildings and wider roads create urban sprawl spreading across the countryside. Perpetuating this approach will ultimately lead to situations where citizens lose

themselves in the built environment and road users in the plains of asphalt pavements. This lack of creativity and pursuit of quick wins will produce an environment that no longer reflects the needs of human beings. Society’s demand for liveable surroundings requires a new design concept: **human design**, the harmonisation of the dimensions of the built environment and infrastructure with human dimensions. Aligning the dimensions to the main users gives expression to what road infrastructure and built environment should be: places designed and developed for human beings. Human design supports the understanding of local situations and thus promotes safety, security and better behaviour among the users of public spaces.

**6.3 Projects required**

HUMAN INFRASTRUCTURE	
<b>Direction of solution</b>	<b>Projects and key issues</b>
<b>Public security</b>	<ul style="list-style-type: none"> <li>• Design and configure infrastructure and public spaces, which are well organised and recognisable in order to inspire confidence of the potential users.</li> <li>• Develop driver supporting vehicles and infrastructure to minimise the impact of driver errors, e.g. with the help of guiding and warning systems.</li> <li>• Design more direct and separated connections for the most vulnerable road users, in particular pedestrians and cyclists (stimulate walking and cycling)</li> <li>• Design urban infrastructure that will reduce the impact of traffic (noise, pollution and vibration).</li> </ul>
<b>Multi-functional use</b>	<ul style="list-style-type: none"> <li>• Conquer and exploit the third dimension of public spaces by means of underground building or creating an artificial ground floor level.</li> <li>• Design aesthetical infrastructure in alignment with its environment.</li> <li>• Use streets differentiated in time to facilitate exploitation and maintenance.</li> <li>• Redesign monotonous office and industrial areas to become multi-usable public space.</li> </ul>
<b>Human design</b>	<ul style="list-style-type: none"> <li>• Design and align the dimensions of infrastructure and the built environment in accordance with its main users.</li> <li>• Reduce traffic needs by designing compact cities.</li> </ul>

**6.4 Developments required**

**6.4.1 INTEGRATED MODELS OF URBAN DESIGN**

The public space in urban areas is very popular in the sense that many potential users claim square meters for their specific demands and expectations concerning safety and security. Pedestrians, cyclists, cars, trucks, trams, city dwellers and last but not least the citizens themselves expect facilities and services that meet their daily needs. Integration of this range of functionalities into the generally scarce public space available will be a tremendous challenge for city planners. They face seemingly unsolvable complex problems. What are the best routings for bus and or tram lanes in the city road plans from the humanitarian and engineering point of view and how to incorporate such lanes into the



street profile (horizontal integration) warranting the safety of other users of the public space? How to configure this bus lane recognisably with respect to the application of materials and components (vertical integration)? Etc., etc....

In brief, the design of cities and their urban infrastructure is essentially concerned with problems connected with the different scales (from road material properties to the shape of cities) and disciplines (from traffic engineers to landscape architects). Each scale acts according to its own specifications and conditions and each discipline talks its own language. Tuning all these different but related specifications and conditions is not only very time consuming but also involves possible misunderstandings and miscommunication which tempers the resolution and affects the quality of the final result of the design process.

Today, city planners lack the tools and knowledge to model and tune the relations between all scales and professions of urban design over the complete range from technical problems to planning issues. These relations are essential to the final qualities and performance required by users and owners of urban infrastructure. In order to streamline the processes of design of infrastructure facilities in urban areas, conceptual and operational tools describing and explaining the horizontal integration as well as the vertical integration are essential. These tools have to support the process of creating robust, well-founded designs of urban facilities.



Work package 1, “Urban infrastructure”, of NR2C has provided the professional community with a set of “global design models”, intended to articulate the various disciplines, knowledge and points of view implied by the design of multi-modal streets. These models are part of a whole set of new concepts, methods and specifications for street design. They describe and explain both how some specific kinds of streets work and achieve special qualities and how actors should cooperate in their design to support. This research has mostly achieved horizontal integration. Here we propose expanding this research in 3 directions:

- *To develop and reinforce the horizontal integration* that has been started in NR2C: to create more numerous *design models* to give a whole and consistent approach to street design.
- *To extend the methodological and conceptual tools both at the upper scale and at the lower scale in order to achieve vertical integration*: “urban patterns” at the upper scale (new routes and mobility organisation at the scale of the urban fabric) and street materials at the lower scales (new processes, new materials and new geometrical forms, etc.)
- *To give to this design tool a European dimension* by collecting and uniting in a single web based interface various design models coming from different European countries, organised into a semantic database allowing intelligent navigation and research into the urban design solution space.

Consult Annex IX for further information about this project.

# 7

## Making it comes true

Perhaps it has something to do with starting a new millennium, generally an excellent time for looking back and ahead. Or perhaps people are feeling daunted by the huge problems and issues we are currently facing and are curious to know what more awaits us. Who knows, but it is interesting how many activities have been initiated to describe and imagine the future. Long-term visions, including strategic research recommendations related to mobility and transport, have frequently been presented in recent years. Based on one such vision, this document is presenting the research activities required to face the future in the domain of road engineering with confidence. However, the work does not end with describing visions and ambitious research programmes. That is only the stepping-stone on the route of progress. All partners and stakeholders involved agree that the recommended research programmes must be carried out. However visions and ambitions do not come cheap. Because of their empirical character, innovations in the road building industries are synonymous with high and long-term investments. So one of the main questions will be: which of the partners will take the lead and be responsible for implementing these research programmes? Or in less politically correct terms: who will pay the bills? A certain awareness of the environment and culture of the road engineering market may be helpful in searching for an answer.

### **7.1 Innovation in practice**

Innovation is still a popular item on the political agenda. It is supposed to increase productivity in the corporate sector, which will in turn improve the economic development of Europe. Because of the economic importance of innovation, a survey was recently held by EIM Business Policy to determine the most innovative sector in the Netherlands. More than 8,300 companies from 58 different sectors were questioned about their innovations strategy and policy. The answers were processed on an innovation barometer topped by the Chemicals and Plastics industry as the most innovative sector. The road and hydraulic building sector is number 56. At first glance, this may seem typical for the Netherlands, but we do not know indications that this poor ranking on the innovation barometer is different in other European countries. It might be explained by the fact that this concerns the part of the sector which actually carries out the work, i.e. contractors (selling man-power) and suppliers of building materials. Due to comprehensive standards and regulations, there is little room for differentiation between the products and services these companies must provide. As a result, the companies themselves have little opportunity to excel or stand out above the rest: a road is a road, asphalt X is asphalt X and concrete class Z is concrete class Z. This situation is reflected in the way commissions are awarded (lowest price), in the specifications and the contracts. Low risks, little willingness to invest in innovation and low benefits could be the non-marked arguments. All in all, these are not the best conditions for getting the innovative sparks flying.

However, all this does not mean that developments in the field of road engineering have stood still in recent decades. On the contrary: much has been changed, revised and improved to achieve the present high level of mechanisation and quality standards of products and constructions. Looking at the distinguished levels of innovation (on the next page), these developments must be placed in the category of restyling that represents 90-95% of all development activities in the sector. In fact, it is more correct to refer to 'improvements' rather than 'innovations'. The progress is an accumulation of carefully chosen small, incremental improvements of existing concepts. The restyling level has a low barrier regarding experimentation. Existing test instruments are usually sufficient. The application risks are low because, in general, the work involves optimising existing concepts. The question is whether continuing to optimise and extrapolate will be adequate to meet the requirements imposed on the infrastructure in 30 or 40 years' time. At any moment, the progress made in ongoing optimisation of existing concepts will no longer meet these requirements, so that changes in the concepts will be necessary. The time has come for the sector to focus more on redesigning concepts to face the future demands with confidence. The redesigning level is far more challenging and involves breaking new ground. The risks to be taken to achieve success are greater and the development time and costs will increase explosively. As a result, the sectors' attitude concerning innovation must change too on both

sides: road authorities and/or principals as well as corporate sector and/or contractors. The rethinking level comes into the picture after 'crises' situations. Rethinking involves throwing existing concepts overboard in the assumption that going on with them will ultimately lead to a dead end. External developments, and these are often autonomic, prompt us to seek totally different approaches.

#### Levels of innovation

- **Restyling (90-95%)**  
*(improvements, conducting activities better, faster and smarter)*
  - Making improvements
  - High Speed Train (actually based on an old concept)
- **Redesigning (5-10%)**  
*(innovations, conducting existing activities differently)*
  - Quiet asphalt
  - Recycling of materials
- **Rethinking (sporadic)**  
*(making breakthroughs, developing and introducing new concepts and activities, approaching problems differently)*
  - Delta Works, detention reservoirs/overflow areas
  - Magnetic trains

## 7.2 Innovation attitudes

The key question is: how can we achieve a more innovative climate in the sector? As in every economically driven sector, the answer today is as simple as it is obvious: create more market forces. Bring about a situation in which companies must compete more with one another. Give the sector more responsibilities and it will be flooded with innovations. Instead of giving them elaborate, detailed specifications, give them specifications based on performance in which the envisaged product is described in terms of function. In this way, agreements on the roles of all the parties involved in innovation will arise tacitly:

- The realisation of innovations is primarily the task of trade and industry. The latter have the required production facilities.
- The creation of the limiting conditions and the initiation and stimulation of innovations is the government's job. The government must clearly indicate its plans for the long term.
- The money invested in development will depend on 'who wants what'. If the government specifically asks the market to come up with an innovative solution, then it will have to make a substantial contribution to the costs involved. If a contractor launches a new product, which has not specifically been requested, it will obviously have to foot the development bill itself.

In themselves, these agreements are very clear and also clearly distinguish between those who expect innovations and those who have to develop them. Unfortunately there is one setback: the parties involved interpret these agreements differently 'backstage'. With respect to developing innovations, the current decision and policy makers on the side of the principals, who are mainly government road authorities, supported by the rhetoric on the other side of the table, have their own vision about this matter.

- Government departments and/or road maintenance authorities feel that innovations are necessary to be able to keep traffic moving in the future. They do not see themselves as the only ones with the problem. Mobility is a social problem rather than purely a government problem. The corporate/private sector has to accept its share of the responsibility too.
- The corporate sector has been saying for years that it can do everything better, faster and cheaper. Well, let them prove it. Bring on those ideas for solutions.

- Innovations are mainly important for the continuity of the sector. Companies that wish to survive will have to regularly launch new products which are improvements on the old ones. By investing in the development of new products and bearing the risks in the form of longer guarantee periods themselves, companies will show that they believe in an innovation. And that such innovation holds economic prospects, too.
- Why is innovation in our sector always so laborious? Serious research and development has been conducted in road engineering for fifty to sixty years, so we should know the buttons we have to push to improve the situation by now.

This reasoning reflects the spirit of modern times and is in any case very pragmatic. Society is inundated with innovations every day. It is practically impossible to keep up with them: a new mobile telephone is launched every six months and a new model of our favourite type of car appears every four years. The corporate part of the sector, which is expected to look after itself, is responsible for its own survival. Because one mistake can mean the end of a company, contractors have another interpretation based on practical experience.

- Road engineering is an empirical field. It does not have the instruments to demonstrate the behaviour of a product in the long term. As a result, a very long and costly process must be followed before new technology is given the stamp of 'proven technology'. With the current profit margins in the building industry (2 to 3 %) it is irresponsible in terms of business economics for the sector to bear the high development costs alone.
- After the first practical application, the innovation is literally and figuratively "out there on the street". The first clones appear on the market within a couple of months. What is the point of being the first to stick your neck out? It is much more interesting for a contractor to improve its own technical and logistic processes. That stays "in house" and the profits from these improvements flow directly into the companies' own resources.
- The various government authorities dominate the client side of the market. Road building is not a consumer market. Ever seen a contractor advertising his products on commercial television? The authorities are reliable clients when it comes to paying, but they are pretty unpredictable with regard to buying. An economic recession or a change of government during the development process of an innovation can totally alter the interest in a new product from one day to the next. Along with the high risk of rapid imitation (and the subsequent rapid erosion of the knowledge advantage), the probability of recovering the investment decreases.
- An innovation usually replaces an existing product. It must have added value compared to the existing product (otherwise it will not sell). The price/performance ratio must be at least equal to that of the existing product, but preferably better. The question is: how is the client going to evaluate the better price/performance ratio during tendering? In the case of a lower price and a better performance, the situation is clear. Things are different if a higher price has to be paid for better performance. Will the client award the contract solely on the basis of the initial project costs or on the basis of life cycle costs, because, for example, the maintenance costs are lower in the long run?

#### Caricature attitudes:

Attitude government authorities	Attitude private partners
<ul style="list-style-type: none"> <li>• Innovations are necessary,</li> <li>• Private partners are eager, so wait and see,</li> <li>• Investments and risks are the responsibility of innovators,</li> <li>• Innovating is a piece of cake.</li> </ul>	<ul style="list-style-type: none"> <li>• Investments and acceptance procedures are out of proportion,</li> <li>• Innovations can easily be imitated after the first application,</li> <li>• Return of investment is doubtful,</li> <li>• Award of contracts is not transparent: lowest costs or cost/performance?</li> </ul>

### 7.3 Rules of play for innovations

It cannot be denied that road authorities and contractors have different expectations and views regarding the desired innovation climate. A “wait and see” attitude until one of the parties makes a move is the worst imaginable scenario and must be prevented. Better understanding of what innovation really entails and acknowledging each other’s interests is a better approach.

Make no mistake; innovation generally consists of a spark of inspiration, followed by a long period of extremely hard work. Innovation is a matter of being able to hold out for a long time - and money, of course. Crucial on the way to success is always the phase of transforming the prototype into a mass product. The prototype could be made by hand, but in the following phase this process must be transformed into an economically viable method of production. In this phase the ultimate feasibility, quality and price of the new product are determined. In this transformation phase, a start also has to be made on the quest for the first customers. Many high hopes of success are cruelly dashed at this point, given the fact that more than 95% of all inventions and innovations never survive this phase.

The road building sector deals with products which have to function for fifteen to twenty years and sometimes much longer. The average customer only buys a new product once it has been sufficiently validated. He wants certainty that he is not throwing money down the drain. He requires proven technology and proven products. And this is where the highly empirical nature of road building causes problems. The present lack of fast tests measuring long-term performance means that validation must largely come from demonstrations and tests carried out under practical conditions. So we first need to find customers who have the nerve to apply the product and are prepared to take the risks involved. And these clients must be willing to pay for the privilege, too. (This seems strange, but it is actually quite normal. The buyers of the first ‘flat screens’ also showed guts, took risks and paid very high prices.) The transforming and validation phase go hand in hand. In the meantime, the investment proceeds and no one has earned a single Euro. But time passes too, of course. If it is only the contractor who bears the risks, this situation does not invite innovations.

The above also shows that every comparison between road building products and consumer articles stops here. Even during the development of a new product, the contractor depends on the cooperation of risk-bearing customers. And if he succeeds in launching a new product on the market after high investment costs, he has very few possibilities for tapping new markets of revenue to expand his business. Advertising is a waste of money because the varying volume of business is dominated by political decisions year by year and shared among one dominant category of clients. These customers are primarily socially responsible for supplying well functioning road networks and depend on contractors to achieve these social requirements. In this context, the question “What are the benefits for the contractor to develop a high performance surface layer with a lifetime twice as long?” is a delicate one.

#### **Characteristics road building market**

- There is one dominant category of clients.
- Volume of business dominated by political decisions.
- Road building is not a consumer market.
- Long-term investments are necessary because of the empirical nature of road building.
- Return on investments is uncertain.
- Which parties see themselves as the ones with the problem?
- Who is responsible for what?

In fact, the road building market is more a closed than an open one, which is why the relationship between client and supplier is different from that in a consumer market. The road building industry has never been and never will be a consumer market in the true sense of the word. In the road building

sector, the client and supplier, or commissioning authority and contractor, are condemned to each other to a certain extent, certainly with respect to innovation and knowledge development. Consequently, all parties involved have to work together and there is no point waiting to see what the other players are going to do. To guarantee continuity of developments in the sector, cooperation is essential. Cooperation is also crucial for keeping society on the move at an acceptable price. Remember that in every European country a substantial part of the Gross National Product is fed by the mobility and transport sector.

Because cooperation in the field of research and development is so crucial, it goes without saying that the dominant partners involved in the road building industry should at least agree on and establish their roles and responsibility in development processes in advance. Drawing up clear 'Rules of play for innovations' and adopting these roles and responsibilities is one of the most essential ways of bringing the research projects recommended in the present document into the implementation phase. These rules will help avoid frustration during the innovation process on all sides and prevent money and energy being wasted. The diagram below shows the initial set-up for a framework for these rules of play for innovations.

#### **'Rules' of play for innovations**

- The contributions of the various parties to the development costs.
- The process to be followed with the innovation.
- The decision moments during the process, including criteria.
- The expected completion time.
- An estimate of the probability of success.
- Risk spread.
- How to deal with patents.
- How to deal with specifications with innovations during tendering.



# 8

## Developments Required

The visionary studies conducted in recent years conclude unanimously that road transport is and will remain the dominant means of transport of people and goods for many decades to come. Over the period 2000-2020, forecasts expect a 35% increase of passenger transport and even a 70% increase of the transport of goods over the European road networks. The constantly growing number of road vehicles means a continuous increase in traffic volumes and axle loads, accelerating developments like congestion, wearing and tear of structures and last but not least air pollution and noise emissions. And these developments are going fast, in any case faster than usual over the past twenty years. The road building industry is faced with huge challenges, including ambitious demands such as better, quicker and cheaper production, construction and maintenance. To minimise downtime of roads for maintenance activities, the overall quality of the structures must be upgraded. The time slots available for repair and rehabilitation works are becoming tighter and tighter, meaning that maintenance techniques have to be speeded up. Furthermore, the environmental regulations introduced to meet with respect to air pollution and noise emissions by traffic and the use of natural raw materials are also becoming stricter and stricter. As outlined in the previous chapters, these developments are also evoking a new generation of questions and problems. It is up to the road building industry amongst others to satisfy policy makers and up to road authorities to provide the right answers and solutions to keep the traffic running on a sustainable basis in Europe.

There is still plenty of progress to be made in the construction and maintenance of infrastructure. However, at any moment, the progress in ongoing optimisation of existing concepts will no longer meet the demands and requirements, so that changes in the concepts will be necessary. To achieve these ambitious goals, the sector must move faster in the direction of the innovation level of redesigning existing concepts. Therefore the introduction of new proven research technologies from other sciences such as physics and chemistry is vitally important.

A new generation of problems requires a new generation of approaches in setting up research. In this context and without diminishing the interest of other projects listed, NR2C has selected a number of projects, labelled as 'Developments required', requiring special attention of all stakeholders involved.

### Developments required:

- New age binder design technologies.
- Integrated models of urban (human) design.
- Lifetime engineering for roads.
- Asset management tools.
- Modular prefabricated pavements.
- Low temperature asphalt with reclaimed asphalt.
- Bridge eco-assessment.
- TYROSAFE: optimizing tyre-road interaction.
- Energy controlled pavements.

These projects aim at upgrading the innovation level in the road engineering sector and thus change the mind set from 'traditional' and 'conventional' to 'high tech' and 'sexy' because they are amongst others:

- Crossing the traditional borders of the common research approaches,
- Incorporating knowledge from other sciences,

- Provoking and challenging engineers to cross the borders of traditional solutions,
- Delivering fundamental basic knowledge for break through inventions,
- Receiving common interest of all European countries.

These projects will provide the sector with new basis knowledge standards for trend setting developments and innovations needed to face the future with confidence. Based on the core competences each project has been allocated to one of the four road construction concepts. In general however a 'Development required' will contribute to solutions of one or more of the other concepts.

The 'Developments required' projects are synonymous with high research investments in the initial stage of development through which European-wide cooperation and governmental support and funding become the key factors to success.

## REFERENCES - ACKNOWLEDGEMENTS

- [1] Vision: Road Transport in Europe 2025, FEHRL, April 2005.
- [2] Vision 2020 and challenges, ERTRAC, June 2004.
- [3] European Energy and Transport trends to 2030, European Commission Directorate-General for Energy and transport.
- [4] Bevolkingstrend, statistisch kwartaalblad over de demografie van Nederland, Jaargang 41-1e kwartaal 2003, central bureau voor de statistiek.
- [5] Note No 1, WP0 Brainstorming, Swiss contribution, A. Junod, November 2004.
- [6] Vision 2040: Analysis and report on the results of the questionnaire distributed in Belgium, A. Vanelstraete & P. Bauweraerts, December 2004.
- [7] NR2C-Denmark, Workshop on road transportation innovations, F. Thøgersen, December 2004.
- [8] La rue du future, Approche sociétale Innovations technologiques, J.-P. Christory, B. Mahut, J.-M. Piau, E. Barré, D. Miet, January 2005.
- [9] Note N° 1, WP0 Brainstorming, Vision workshop Slovenia, A. Žnidarič, May 2005.
- [10] Contribution to the deliverable D 0.1, a draft Vision 2040. Answering to the questionnaire, M. Luminari, September 2005.
- [11] NR2C Workshop-Poland, A. Adesiyun and A. Wysokowski, November 2005.
- [12] De meest innovatieve sector van Nederland, EIM Business Policy, August 2005.
- [13] Strategic Research Agenda for the European Underground Construction Sector", draft, ECTP, October 2005.
- [14] NR2C Workshop-Sweden, B. Kalman,
- [15] Intelligent Roads (INTRO), Specific Targeted Research or Innovation Project, European Commission, October 2004.
- [16] New Road Construction Concepts: Vision 2040, FEHRL, July 2006

# Part B

**Some specific innovations developed in NR2C**







# 9

## Towards more human infrastructure

### 9.1 Introduction to "multi-modal and multi-level design models" of streets

David MIET  
Laboratoire Régional de l'Ouest Parisien LROP – France

#### Abstract

"Multimodal & multilevel design models" of streets form a new conceptual instrument whose main purpose is to support cooperation in street design. Throughout the work of defining, evolving and refining a street project, this approach provides all "co-designers" with: (1) a method for organizing the design tasks and processes in such a way as to initiate both technical and political co-operations between the various people involved, and (2) some constellations of well-built, well-thought and well-tried models of streets, avenues, bus lanes, sidewalks, districts, arcades, boulevards... meant to constitute reliable supports and rich resources for the running of such a method. This article shows how these models & method may initiate the building of a kind of an urbanistic knowledge and how, finally, this urbanistic knowledge may support the grounding and restructuring of street design.

#### 9.1.1 CONSIDERING THE MANY FACETS OF "URBANISTIC KNOWLEDGE"

What are the main functions and purposes of street "design models"? Which specific problems do they solve? What questions do they answer?

In a design process, design models help owners, clients and inhabitants to elaborate more precisely what they really expect and need while writing a street programme. They help designers to easily generate a wide range of alternative design scenarios responding to such desires. And they finally help clients, owners and inhabitants to compare those scenarios so as to be able to choose among these open possibilities.

Once a given design process has been completed, design models of streets help new designers not to undo this work but to continue, to develop and to refine, throughout the several scales and stages of a new design process (or throughout several successive design processes) what has yet been achieved by other "co-designers".

More largely, design models should help to integrate the many available sectorial methods of analysis and their resulting conclusions (from lighting engineering, acoustics, road safety, air pollution, aesthetics, traffic engineering, psychology, economics, environmental sciences, anthropology, sociology,...) into global and operational street design processes.

In a long term perspective, these models may also help the urban design and planning profession to initiate the testing, the assessment and the improvement of its proper practices and technical concepts.

In brief, design models of streets support collaborative design processes by providing a sharable language for discussion, and interdisciplinary research processes by articulating into common conceptual frameworks several concerns belonging to heterogeneous disciplines.

How is it possible, then, that this single instrument may help with so many huge difficulties?

Design models are first of all an attempt to build a sort of an urbanistic knowledge. They have not been invented and formalized to solve one or another specific “problem”. Rather to organize and to improve the knowledge of streets, this not from a traffic point of view, nor from an anthropological point of view, nor even from an environmental point of view... Not from any analytical point of view that can be taken to study “what is a street”, but from the formal point of view of street design, which naturally involves all of these concerns, criteria and dimensions into a synthetical process of imagination and definition of “what a street could be”.

The potential usefulness of “design models” of streets and their urbanistic method might thus be better apprehended by asking the following question: what are the problems designers have to face which can be said to result from a lack of a certain urbanistic knowledge? The answer to this question is quite clear... and potentially endless. It encompasses all of the purposes of cooperation we just started to list, for the problems they face are direct consequences of (1) the specific character of urbanism, (2) the specific role of knowledge in a design process.

(1) “Urbanism” is to all urban trades, disciplines and approaches what “architecture” is to building trades, disciplines and techniques. Urbanism essentially deals with questions of multimodal and multilevel co-operations: organisations of various urban scales, elements, spaces, objects, devices, functions, uses, experts, specialists, trades, skills, criteria, concerns, dimensions and knowledges.

Note that all these kinds of multimodal and multilevel co-operations can hold two significant facets:

- The first is technical (urbanistic) and belongs to all professionals involved in the creation and transformation of street elements, streets, street patterns and cities: the articulation of spaces, buildings, flows and materials depends upon our urbanistic knowledge.
- The other is political (strategic) and belongs to the owners and administrators of the work, to clients, inhabitants and their political representatives: the articulation of needs, uses, goals, opinions, purposes, ways of life... depends upon the society political visions, principles, devices, skills and decision making processes.

(2) Now, to be usefully incorporated in a design process, any knowledge should satisfy two conditions:

- Being able to support imagination, to engage the formal (i.e. mental) conception of technical and political organisations, the transformation of existing concepts into new solutions, the distribution, composition and combination of forms, ideas and patterns.
- Being able to support prediction, to engage the evaluation of the technical and political consequences of a design, the formulation of alternative hypothesis, the recursive adjustment of rough drafts into more and more precise and sound solutions.

The lack of a true “urbanistic knowledge” (a knowledge of multilevel and multimodal organisations useful for the design of cities) is thus, apart from the lack of cities political organisation, the main source of all difficulties encountered in the production of streets, and this for two reasons. First because it creates innumerable difficulties of cooperation between experts, trades, disciplines and designers of all sorts which do not share reliable concepts that would allow them to imagine and to predict together, i.e. “urbanistically”. Second because political processes of deliberation (political imagination and prediction) regarding urban questions are nearly impossible to achieve without the emergence of a consequent urbanistic support.

The kind of urbanistic knowledge we have started to develop has thus been elaborated as a support for both imagination and prediction activities, and this from both technical and political points of view.

This urbanistic knowledge is also two-fold in its constitution, for every unit of this knowledge can be seen as some sort of content on the one hand and as a kind of method on the other hand.

- Design models are URBANISTIC MODELS: evolving pieces of organised, articulated and combined theories; multilevel and multimodal concepts of streets, avenues, bus lanes, arcades, sidewalks and other urbanistic entities.
- And design models express an URBANISTIC METHOD: multilevel and multimodal design principles, stages and operators based on the handling and crafting of these models and inviting designers to step, progressively, from the particularly notion of “urban project” to the more general one of “multilevel and multimodal design of urban transformations”.

### 9.1.2 RESTRUCTURING STREET DESIGN: COOPERATION THROUGH ALL STAGES OF A DESIGN CYCLE

As an urbanistic method, “design models” first aim at constituting a methodological support for the consolidation and instrumentation of street projects. In this regard, our approach postulates that the task of a “cooperative design” essentially consists in the act of transforming some existent designs: in continuing, extending and developing the results of other co-designers working simultaneously, in parallel or even before the engagement of any design task. Here is an example.

Before to be rebuilt, an existing boulevard, may “say” three kinds of things: (1) “I go from that place to that one”; “I am 8 km long and 50m wide”, etc. (2) “People use me to go shopping”; “they use me as a promenade on Sundays”, etc. (3) My form, which is circular, clearly indicates to people the direction of city-centre”; “it also provides changing perspectives which may be pleasing for a promenade”; “my width, which is twice that of all ordinary streets, shows to my drivers that they have the priority”, etc.

Hence, for any person or group of people susceptible to cooperate in a design process, “engaging a new design cycle on the basis of a former design cycle” requires the ability to understand 3 things: (1) the more or less precise and concrete spatial arrangements that come as a result of the previous design; (2) the purposes, needs, intentions and expected uses these arrangements are meant to serve; (3) the forms, mental ideas, conceptions, principles and modes of organisation explaining in what intelligent ways those arrangements may support those uses.

The essential contribution of our urbanistic method thus lies in the reintroduction of the notion of form (which is neither a material “shape”, nor a physical “appearance”, but a mental “pattern”) as an essential element articulating the notion of uses (needs, perceptions, performances, goals, aims, purposes, problems... which are political matters) to that of arrangements (solutions, physical configurations, spatial dispositions, devices... which are technical matters). In doing so, our goal is to bring to all potential designers the possibility to know and to make use of that forms that are underpinning the urban arrangements they have proceeded to transform: to invite them to really participate to the design (i.e. imagination & prediction) of new streets.

Cooperation will thus be achieved by bringing the notions of form at the core of each stage of a “design cycle”: by restructuring the common stage of “diagnosis” into a “formal diagnosis” through distribution & composition, the common stage of “programming” into a “formal exploration” through transformation & multiplication, and the common stage of “design” into a “formal synopsis” through assembling & tuning. This is how:

- The stage of FORMAL DIAGNOSIS may appeal to inhabitants themselves, residents and users, to their political representatives and to the specialists and experts in charge of various analysis and preliminary studies.
- The stage of FORMAL EXPLORATION may involve owners, users and the team of designers when those are to define the orientations and possible options for the transformation of the existent site and practices.
- The stage of FORMAL SYNOPSIS (definition of a global vision, a master plan, a preliminary design...) may be elaborated by designers with potential participations of inhabitants and various

trades going from the lighting engineer to the ergonomist, through the traffic engineer, the psychologist, the expert in road safety, the anthropologist, etc.

**Formal diagnosis: building a continuous distribution & composition of multimodal and multilevel design entities, each gathering a local pattern of uses, forms and arrangements.**

The building of a “diagnosis” preliminary to the definition of a new urban design is confronted with two sorts of difficulties:

- A potentially indefinite number of preliminary studies may be usefully conducted to understand the existing environment and its functioning such as analysis of traffic, road safety, hydrology, public transports, landscape, acoustics, lightings, etc.
- The articulation and integration of all of these points of view is all the more difficult to realize as they are numerous, partial, heterogeneous, precise and as they tackle issues that concern a high number of people and stakeholders.

To overcome those two difficulties which are inherent to all complex urban environments, the designers’ team shall initiate the distribution of the design work by building an “urbanistic model” of the situation to be transformed. Such a work firstly consists in locating, identifying and naming the significant entities of the studied urban environment. Those entities correspond, more or less, to those familiar and overlapping ideas that everybody has of a street: tree alignments, sidewalks, cyclist lanes, roadways, crossroads, façades, bus stops, districts, corners, piazzas, avenues, building halls, etc. To transform these significant entities into real and useful design entities it is then necessary to proceed in composing each one of them as a kind of “urban field” relatively autonomous in its context. Each field is therefore composed, by hypothesis, of a local and congruent pattern of:

{uses – forms – arrangements}

An urban “field” is a more elaborated composition of a design entity than a physical “zone” or a simple “area”. For fields are intrinsically both moved by internal influences and influencing each other: urban fields are physical, functional and mental entities that necessarily overlap themselves at many scales. Each “design entity” is thus the model of a certain “urban field” considered as a physical space (pattern of arrangements) supporting a certain number of functions, practices and perceptions (pattern of uses) and following certain principles of organisation, certain mental conceptions (forms) that govern its functioning and determine the role it plays in its environment.

What is going to be transformed by the design is thus not only the physical configurations of the site, not simply its concrete constructions but, simultaneously: a certain number of spatial dispositions (arrangements), the purposes they support (uses) and the ideas everybody gets of these places (forms). For it is impossible, indeed, to modify the arrangements and uses of a place without transforming, in the mean time, the conceptions (forms) its inhabitants will build of it.

Establishing a formal diagnosis thus consists in building a model of the urban environment and its functioning as a synthetic description of the multiple urban fields that are distributed, overlapping and interlocked into each other at all scales, from the city to the sidewalk’s border stones... Each design entity is thus recursively composed of design sub-entities that can be, in their turn, discussed, tried, studied for themselves and linked to other entities at all levels. This is how designers may then be able to coordinate, around each of these urban fields and sub-fields, a certain (limited, thus conceivable...) number of dimensions, theories, trades and disciplines that are not used to communicate with each other: crossing traffic considerations with hydrologic concerns if one is tackling the longitudinal profile of an avenue for example; or confronting the weather forces with the social patterns of space appropriation if one is handling the design of a commercial arcade... hence progressively raising and overlapping some urbanistic problems.

In our first application case for example, which takes place in the city of Wattrelos, we have distinguished first the global design entity of the site to be transformed (Way to the Centre Arrival), to which we attached the analysis which were relevant at the global scale: traffic, image of the city,

transition from natural to urban environment, place of pedestrians, influence of the park. Then five overlapping design sub-entities have been redefined, each one articulating some special and limited concerns. Each of these design sub-entities is then distributed again into several sub-entities that can be taken for themselves and linked to each other. Those links may be physical (a continuous tree alignment for example), functional (pedestrian flow, perception of sunlight, distribution of available parking places...) or mental (the two forecourts of the project are mentally associated with their respective main buildings) allowing these entities and sub-entities to overlap themselves: entity "A1" of Watrelos project for example, belongs both to entities "A" and "B" into which it plays two distinct roles.

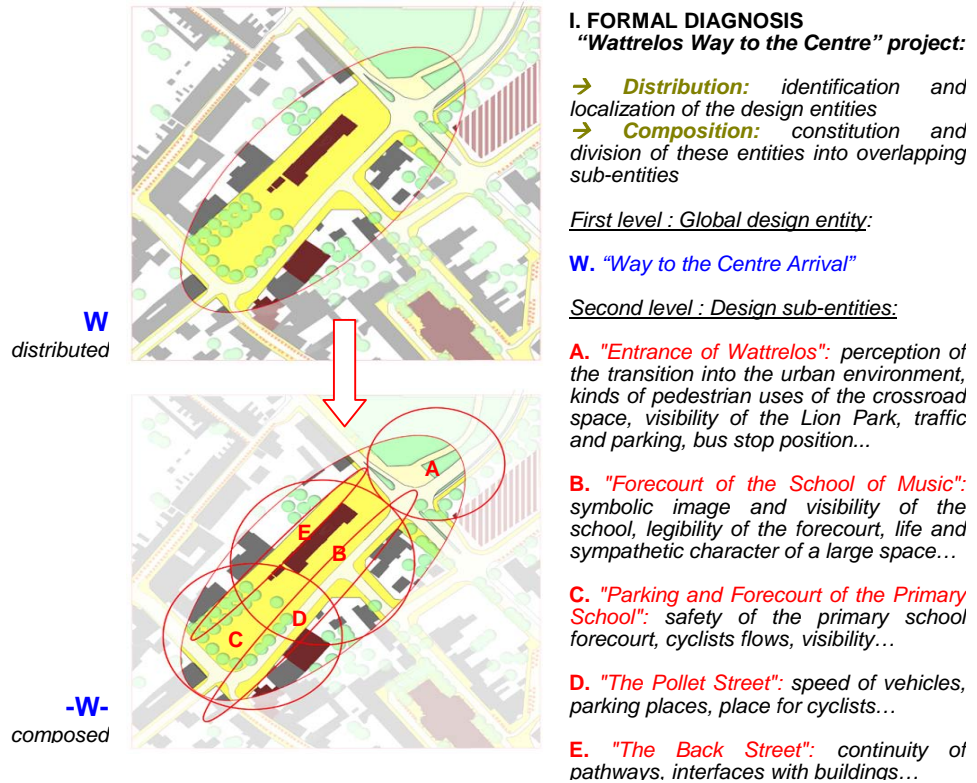

The conceptual model resulting from this formal process of distribution & composition is thus a multilevel set of inter-related multimodal design entities each gathering and confronting some heterogeneous parts of the diagnosis. The “formal diagnosis” is thus done in such a way that these analytical elements may be next easily involved, as “urbanistic problems”, into the following stages of the design cycle.

**Formal exploration: developing, on the basis of each design entity’s multiple potential transformations, the concomitant expression of intentions and configurations**

The stage we call “exploration” or “formal exploration” is the core of the design process. It is very often considered as an impenetrable “black box” only workable in the private mind of the architect, our approach considers, in the contrary, that this stage of imagination is the most auspicious for the development of:

- Users’, clients’ and owners’ proper desires and wills of personal and political organisation.
- Users’, clients’ and owners’ participation to the design process.
- Cooperation between all experts and specialists involved in the design process.

We have managed, while establishing a formal diagnostic, to maintain, for each particular urban field and sub-field of the existent environment, a reasonable number of relevant considerations to be taken into account so that each design entity of a boulevard, a sidewalk, a tree alignment... remains all the time conceivable by all of the involved partners (principle of distribution – conceivability).

We have also managed, in the definition of the design entities and sub-entities, to give a central role to the formal aspect of the studied environment (i.e. the mental aspect: ideas, principles and modes of organization, conceptions...) along with its functional and physical aspects, thus allowing all design entities to be strongly and easily linked to each other (principle of composition – composability).

Nothing is more natural then, for people, owners, designers and experts, than imagining a certain number of successive transformations of each of these conceivable and composable design entities so as to produce, in parallel, a myriad of local explorations of the global solution space:

- By expressing, for each design entity, its potential transformations, re-combinations of its sub-entities and evolutions in terms of some design partis: differences between the existent forms and potential new forms.
- By expressing, for each design entity and its multiple potential transformations, the inhabitants’ and clients’ purposes, needs and wishes in terms of intentions: differences between existent uses and desired new uses.
- By expressing, for each design entities and its multiple potential transformations, the workable solutions, devices and spatial dispositions in terms of configurations: differences between the existent arrangements and workable new arrangements.
- By iterating back and forth, for each entity of the diagnostic, between the formulation of potential transformations and the expression of intentions and configurations, so as to support the cooperative and multilevel exploration of the design solution space.

Each design entity may thus be declined into several and different design options, each leading to a new urban field, i.e. a new local pattern of:

{uses – forms – arrangements}

And each of these design options will be described by a pattern of intentions, a pattern of configurations and some partis answering the problems previously raised by the diagnosis:

[problems] // [intentions – partis – configurations]

**II. FORMAL EXPLORATION**  
**"Wattrelos Way to the Centre" project:**

→ **Transformation and multiplication** of the global design entity into 3 stable and distinct design options:

- W'**. Progressive transition from the countryside to the urban environment.
- W''**. Strong contrast between spaces that are outside of the city and spaces that are inside.
- W'''**. Alternation of spaces with an "urban" atmosphere and spaces with a "landscaped" character.

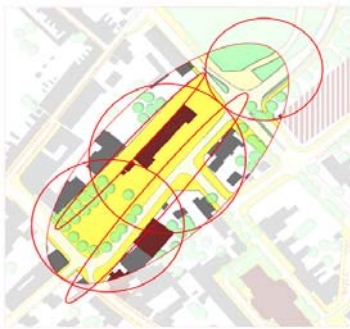

**-W-** initial field

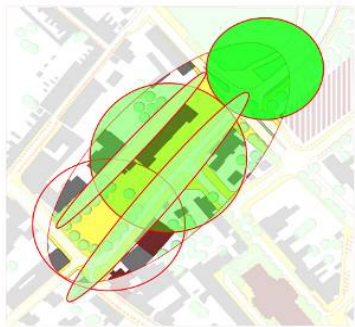

**-W'** - first potential transformation

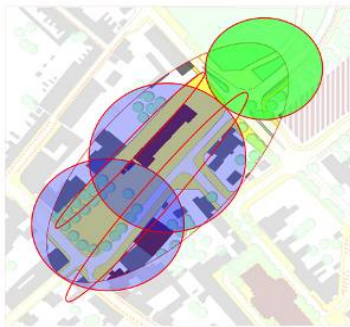

**-W''** - second potential transformation

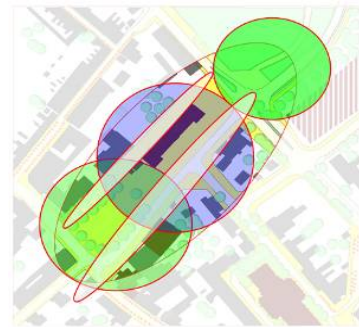

**-W'''** - third potential transformation

**II. FORMAL EXPLORATION**  
**"Wattrelos Way to the Centre" project:**

→ **Transformation and multiplication** of one design entity into 3 stable and distinct design options:

- A'**. Entrance of Wattrelos organized as one and the same space around the crossroads.
- A''**. Door effect to strengthen the passage into a new environment.
- A'''**. Strong link between the school of music and the entrance of the park but without disturbing the fluidity of the entrance.

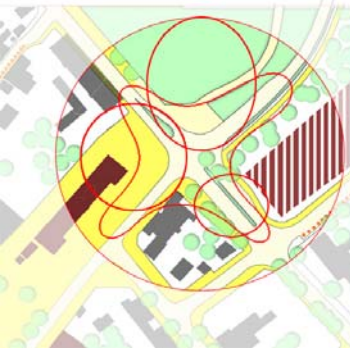

**A** initial field

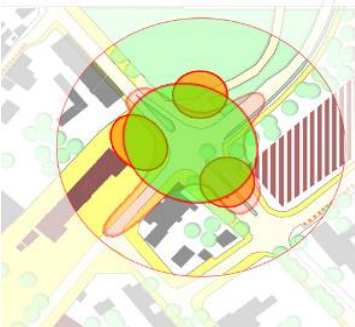

**A'** first potential transformation

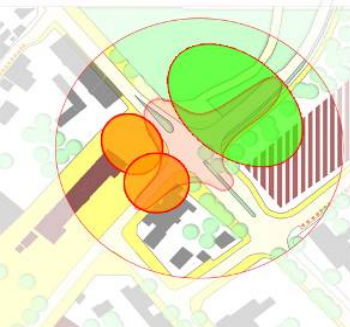

**A''** second potential transformation

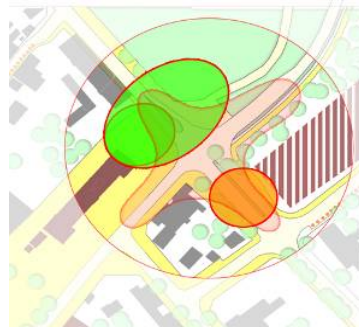

**A'''** third potential transformation

In this way, the ongoing of the design process from the entities of the diagnosis to the design options (from problems to solutions) is made continuous, cooperative and distributed by the mean of an exploration of intentions, configurations and formal partis at the level of each design entity. But these potential transformations, which are relative to each design entity, are not yet integrated to each other into global and coherent design proposals: this is precisely what next stage of the design cycle is supposed to do.

**Formal synopsis: assembling and adjusting into coherent and global design proposals some of the multiple potential transformations, intentions and configurations of each design entity**

We have managed, during the intermediate stage of formal exploration:

- To operate many successive transformations on each design entity so as to reach, each time, some stable, consistent and congruent design options that really have the capacity to answer the problems raised by the diagnosis (principle of transformation – stability).
- To develop a wide range of significant design options exploring the many possible partis, intentions and configurations so as to really open distinct potential transformations of the existent site and practices (principle of multiplication – significance).

Following this opening of the design possibilities, the formulation of some coherent and global design proposals simply consists in assembling and tuning to each other those of these multiple design options that appear as the most promising and consistent with inhabitants' general purposes.

In other words, the design entities which have been distributed and composed during the stage of diagnosis and then transformed and multiplied during the stage of exploration, must now be assembled and tuned to each other through the integration of some global and coherent transformations of the existing site: some "design scenarios". Our whole three-fold urbanistic design cycle is thus structured according to the following three-layered conceptual scheme:

<b>FIELDS</b>	<i>{uses – forms – arrangements}</i>
<b>PROJECT</b>	<b>[design entities] // [design options] // [design scenarios]</b>
<b>STAGES</b>	<b>DIAGNOSIS – EXPLORATION – SYNOPSIS</b>

Very often however, global sketches are immediately produced in response to the preliminary studies and programme, as it is the case in architectural competitions for example. In doing so, these proposals unnecessarily limit:

- The design possibilities to a very restrictive part of street design solution space.
- The role of owners, inhabitants, users and other experts to the simple act of choosing among some limited and already defined solutions.

This stage of integration of one synopsis is, indeed, the proper task of designers. It is not easily shared by other experts or by inhabitants for a drawing imposes, by nature, many geometrical and technical relations between all components of the design. This is the reason why these relations and their consequences are not easily grasped by non-professional designers unless they have been linked to functional and formal issues which are familiar to them.

The introduction of the prior stages of "formal diagnosis" and "formal exploration" is meant to solve this difficulty: it postpones the drawing of a global solution to the end of the design cycle, thus keeping the design open until all entities have been studied and appropriated by people interested in them.



This is how those people may be able to recognize, in the finally integrated design scenarios, the many stable and significant design entities they have explored and their mutual relations. And this is how they will finally be able to cooperate in this last stage of the design cycle: by proposing more relevant combinations of these entities, some new design scenarios elaborated as re-compositions of the first design scenarios (principle of assembling – recomposability).

Moreover, and unlike current practices, which dissociate the expression of needs from the formulation of solutions, our approach postulates that these two movements of the design process should evolve simultaneously. The previous stage of formal exploration is precisely built on this principle that intentions and configurations are only well developed if handled in a concomitant process.

The same principle applies here to synopsis: this last stage of a design cycle consists, essentially, in putting together and getting compatible the whole of the intentions on one side and the whole of the configurations on the other side: a “design scenario” should both express (1) a “spatial synopsis” (a coherent drawing showing some new patterns of spatial arrangements) and (2) a “functional synopsis” (a coordinated programme telling about new patterns of uses).

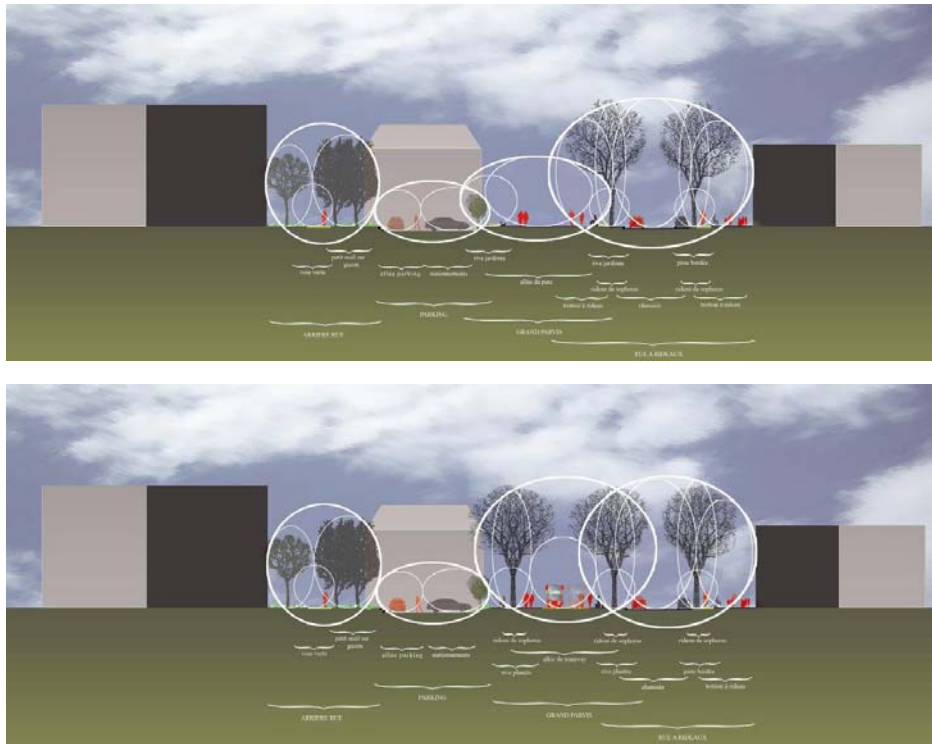

### III. FORMAL SYNOPSIS “Wattrelos Way to the Centre” project:

→ **Assembling and tuning** of some of the potential transformations of each design entity of the project, giving birth to different scalable and decomposable design scenarios.

Here are shown two slightly different scenarios, one including a double tramway circulation on the School of Music Forecourt and the other keeping this space free for pedestrians.

A design scenario communicates both a programme (ways of organizing uses) and a drawing (ways of configuring the public space): they are both a functional synopsis and a spatial synopsis.

But if drawings and spatial representations are usually a good tool for getting the configurations all together and progressively making them compatible, there is not such an instrument to work on the coherence of combined intentions, purposes, atmospheres, functions, ways of life... Most people even think that apart from quantitative aspects (traffic, flows, speed...), “uses” are relative to individuals, to specific social groups or personal perceptions, suggesting that trying to achieve some sound, subtle and precise tuning of the qualities of a street design is impossible.

However, the explicit and continuous logical structure of our method may offer, by allowing a real involvement of inhabitants and various experts at all stages of the design process, some possibilities of precise assembling and tuning of intentions: potential contradictions or crucial complementarities between intentions of various design entities may appear more clearly as those have been associated to some conceivable, composable, stable and significant design options and as this work has been done with inhabitants and future users themselves... For only a good and synthetic knowledge of current and future practices (which is implicitly present in the mind of inhabitants and their political representatives) can help in the precise “tuning” of the functional aspects of a design.

It is, in theory, the precise tuning of both configurations (through drawings) and intentions (through inhabitants participation) of one project that necessarily calls, at the end, for a new “design cycle”: this is how the global form of the project finally shines out, integrating in a same vision the local partis of all design entities.

This tuning (multilevel adjustment) of the drawing and programme details is absolutely not meant to give a “photorealistic” image of the future urban arrangement and functioning (for this mode of representation would confuse the work of the current design cycle into lots of deceiving, unthought and undecided details) but, more importantly, to communicate the mental forms presiding at them. It is this form arising from the current design cycle that will engender the need of new design cycles. In reading the results of a design cycle, people should find themselves in the situation where some things can now be desired and expected that were not previously considered at the beginning of this design cycle: not only does the synopsis should show clearer solutions to urbanistic problems, but the clarity of its form should also raise some new questions, new problems, new goals and new potential expectations, thus inviting to step to a new design cycle (principle of tuning – recyclability).

STAGES	Goal	Operations	Results	Units	Formal Criteria
1 FORMAL DIAGNOSIS	Articulating and confronting the many preliminary studies in such a way that they may be easily involved in the design process.	→ Distributing  → Composing	Several overlapping and imbricated <i>design entities</i> and <i>sub-entities</i> conveying certain urbanistic <i>problems</i> .	<u>Design entities</u> = <i>local fields of {uses – forms – arrangements}</i> // [ <i>local entities – problems</i> ]	* <i>Conceivability</i>  * <i>Composability</i>
2 FORMAL EXPLORATION	Exploring and opening the possibilities at the level of each design entity and equally from users' and designers' points of view.	→ Transforming  → Multiplying	For each design entity, several potential transformations and their related intentions and configurations.	<u>Design options</u> = <i>new local fields of {uses – forms – arrangements}</i> // [ <i>intentions – partis – configurations</i> ]	* <i>Stability</i>  * <i>Significance</i>
3 FORMAL SYNOPSIS	Integrating some of the previously developed potential transformations into global and coherent design proposals.	→ Assembling  → Tuning	Some global and coherent <i>design scenarios</i> for the transformation of the existent site and practices.	<u>Design scenarios</u> = <i>global fields of {uses – forms – arrangements}</i> // [ <i>programme – drawing</i> ]	* <i>Recomposability</i>  * <i>Recyclability</i>

The 3 stages of one cooperative "design cycle": DIAGNOSIS, EXPLORATION AND SYNOPSIS

### 9.1.3 GROUNDING STREET DESIGN: TOWARDS A KNOWLEDGE-BASED URBANISM

This elaboration of the synopsis and the stages of diagnosis and exploration that we have described may essentially be undertaken during the transition from the “preliminary studies” to the “first sketches” of a project. As the Wattrelos application case has shown, they lead to more coherent designs without needing much more work than what is usually practised in relatively important projects.

But in the perspective of a redistribution of the design tasks all along the life cycles of cities spatial arrangements and among all the trade and professionals that may participate in their continuous production, the 3 stages of this “urbanistic design cycle” (diagnosis, exploration, synopsis) may be spread and shared in a completely different production process. They could easily participate to the restructuring of next phases of a project: the precise definition of the master plan, the construction and reception of the work but also, later, during the maintenance and management of the work and, finally, during its successive modifications and transformations all along its life cycle.

The thinking of a true economy of design makes indeed illusory and even inefficient today's concentration of all design efforts into the sole phases of the “project”. Certain needs and certain potential transformations may be better and easier formulated after drawing the first sketches, i.e. when the “programme” is already achieved... for others may appear more clearly and precisely after the first steps of construction, i.e. when the final master plans have already been transmitted...

Hence the opportunity to pass from the notion of “urban project”, which freezes the design at one particular moment of the life cycle of any piece of a city, to the more powerful one of “cooperative and continuously distributed design of urban transformations”. This process would clearly increase the “quantity of design” which is “present” in one street element, one street or one pattern of streets. And this increase has a cost that implies saving some “design resources” elsewhere: here is precisely where the question of “urbanistic knowledge as content” appears, as we have only been discussing, until now, of “urbanistic knowledge as method”.

It may be agreed that better designed streets may lead to various kinds of “savings” resulting from the avoidance of lots of contradictions, conflicts and errors that usually have expensive consequences. It may also be agreed that from the point of view of “long-term global and environmental costs”, the relative rise of the design task may not be as expensive as it seems. And it may finally be agreed, as we have extensively defended this point, that it is possible to better distribute and organize a given “quantity of design” without necessarily increasing it.

But despite all of these arguments, it seems clear indeed that such a kind of restructuring of the design activity throughout the whole process of street production inevitably involves some “more design”: a reintroduction of design in all phases and trades of street production processes:

- For this kind of design restructuring is more oriented toward a rise of quality than towards a saving of costs, labour and human thinking.
- For this kind of design restructuring implies great changes in the way we proceed today and for these changes, like every transition, temporarily need more energy, more entailment and more time spent by people involved.

This is why there is an obvious need to find some available new “design resources”...

Despite appearances, these conceptual resources may not be found too far away: implicit and recurrent models of streets, avenues, sidewalks, boulevards... already exist in the current practices of urban designers. These generic models are applied repeatedly in various contexts and for various reasons, most often unconsciously. There is an underlying economy of design which is yet (poorly) at play and which has not been exploited. On the contrary, most designers involved in the creation of a new street act as if they were designing new prototypes each time they face a new situation whereas, from cities to cities, the same forms emerge to answer the same needs...

The research process through which we might be able to exploit this underlying “economy of street design” and transform it into a more comprehensive “knowledge-based urbanism” parallels, in a way, the process of a design cycle we have just described in three recursive stages:

- **EXTRACTION** of the implicit and generic existing models: the thing to diagnose in the beginning of the research process is not, this time, a specific site and its uses, but some recurring types of situations in which recurring types of urbanistic solutions seem to be implemented.
- **TRANSFORMATION** of the existing models into new design models: the thing to explore is not, this time, some specific potential transformations of an existing site, but generic potential transformations of recurrent street models, aiming at expanding the current street design “solution space”.
- **FORMALISATION** of new design models into well-trying and well-grounded pieces of urbanistic knowledge: the thing to integrate is not, this time, some specific potential transformations into a coherent design scenario, but some generic design models into whole, coherent and useful pieces of theory that can be fluently perceived and manipulated by the minds of people involved in the design process.

Existing implicit and recurrent models have 4 specific qualities that might be kept “intact” if we are to expect the newly formalized models to be still able to support some “fluent” design processes:

- They are largely “sharable”: arcades, roadways, sidewalks, tree alignments... are concepts known by nearly everybody. They are already more or less “shared” and would be easily “sharable” if they were to be refined into an urbanistic conceptual framework. This is why such models do not only form a good support for design processes but also good instruments for cooperative design processes.
- They are “bi-lateral”: an arcade both expresses some problems and some solutions, some intentions and some configurations supporting them, some needs and some devices answering these needs... It is for this very reason that such models are easily involved into design processes as motive elements supporting the alternation between the redefinition of political purposes and the reformulation of technical solutions...
- They are “multimodal”: an arcade is neither a concept of acoustics, nor a concept of lighting engineering, nor a concept of anthropology; it is at the same time some spatial arrangements, some building elements, specific uses and habits, some commercial advantages and a protected atmosphere...
- They are “multilevel”: a same model can involve the positioning of a public bench and the reconfiguration of a district transport plan... From the level of cities to that of the sidewalk borderstones, the whole set of design models can be formalized with a same language thus allowing designer to navigate easily through the many levels of urban organisations.

To sum up these characteristics, we may say that the “content” of such implicit concepts as the “arcade”, the “borderstone”, the “bus lane” and the “boulevard” is already both a functional articulation and a spatial organisation of various spaces and people. This “content” becomes an explicit piece of urbanistic knowledge when its formal aspect has been recognized in recurrent situations and contexts: when the design models of these concepts can be said to constitute logical articulations of the various concerns, trades and disciplines that are relevant to their complete understanding.

In this perspective, design models may thus be formalised as “recurrent and stable design entities”. They are, this time, not local but generic patterns of:

**{uses - forms - arrangements}**

that can be formalized according to the following categories of thought:

**[context – problems] // [intentions – partis – configurations]**

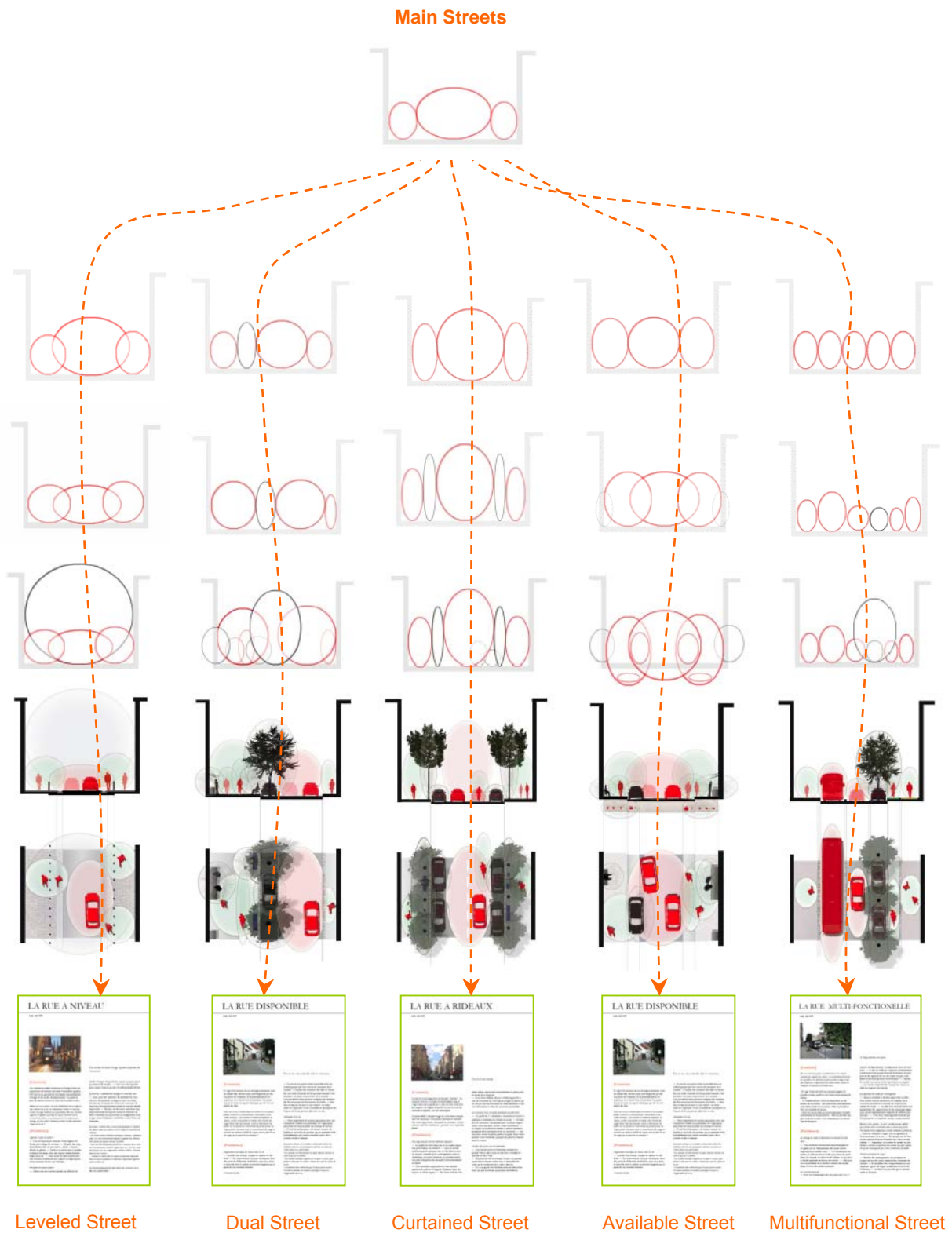

Set of formalized generic “design models”  
all originated into the same shared concept of a “Main Street”:  
Levelled Street, Dual Street, Curtained Street, Available Street, Multi-functional Street

The constellations of design models of streets, avenues, sidewalks, forecourts, tree alignments... that may result from this first layer of urbanistic research (extraction, transformation and formalisation of implicit concepts) will serve during all the stages of the design cycles (diagnosis, exploration, synopsis) of any urban arrangement :

- As supports for imagination: from the considering of details to the understanding of form.
- As supports for prediction: from the considering of form to the understanding of details.

The whole set of design models will constitute, finally, a kind of state of the art of multimodal street design: a sort of know-how that will not belong to one or another particular trade nor to one or another special discipline but that will articulate all of these points of view into a body of organized and sharable empirical knowledge.

In a second phase, without having to wait for the completion of this first layer of urbanistic knowledge, which is quite long and drawn out to handle, given the huge extension of the field of urbanism, we may further consider upper levels of urbanistic models: models of thought more general than the design models of sidewalks, bus lanes, or arcades... design operators that will allow people to browse among the various street ideas, urban forms and their specific models, to generate new design models from existing configurations, to explain in a more general fashion certain mechanisms which are common to several models, to improve the formulation of current models... This leads to a second part of the task of building urban design models: to the formulation of a second layer of the urbanistic knowledge which is emancipated from the empirical models of streets, avenues, sidewalks... and mostly aiming at proposing to designers some powerful instruments for the research process of extraction, transformation and formalisation of existing street models.

#### 9.1.4 CONCLUSIONS

This whole work has only been started within the NR2C project. but the methodology for making street projects, design models and design operators has been drafted and is now available for improvements and more extensive applications:

- Our method oriented on **DESIGN ENTITIES** has been applied in the Wattrelos project and has allowed a continuous cooperation leading to a programme and the drawing of first sketches. This method is now documented and usable for new projects.
- Some generic **DESIGN MODELS** have been formalized and are available to support the design of multimodal and multilevel street projects : 5 models of “ main streets” , 5 models of “ bus lanes” and 5 models of “ avenues and boulevards” , showing a wide range of alternative modes of organizing the urban realm.
- A set of **DESIGN OPERATORS** has been created in order to help interpreting, transforming, organizing and formalizing new design models that may involve subjects which have not been treated in existing ones.

Those design models and design operators have not yet been directly confronted with theories and models from other disciplines. They are now available for such a future work of consolidation.

#### REFERENCES

- NR2C – Deliv. 1.2: Specifications and preliminary concepts for the design of multimodal streets.
- NR2C – Deliv. 1.3: Design models for the design of multimodal streets.
- Alexander Ch. et al., A Pattern Language, Oxford University Press, New York, 1977.
- Alexander Ch. et al., A New Theory of Urban design, Oxford University Press, New York, 1987.
- Coomaraswamy A. K., The transformation of nature in art, Harvard University Press, 1934.
- Choay F., La règle et le modèle, Seuil, 1981.
- Gourdon J-L, La rue, essai sur l'économie de la forme urbaine, éditions de l'Aube, 2001.
- Le Moigne Jean-Louis, La modélisation des systèmes complexes, Dunod, 1999.
- Lynch K., Good City Form, MIT Press, Cambridge, 1981.
- Marshall S., Streets and Patterns, Spon Press, London, 2005.

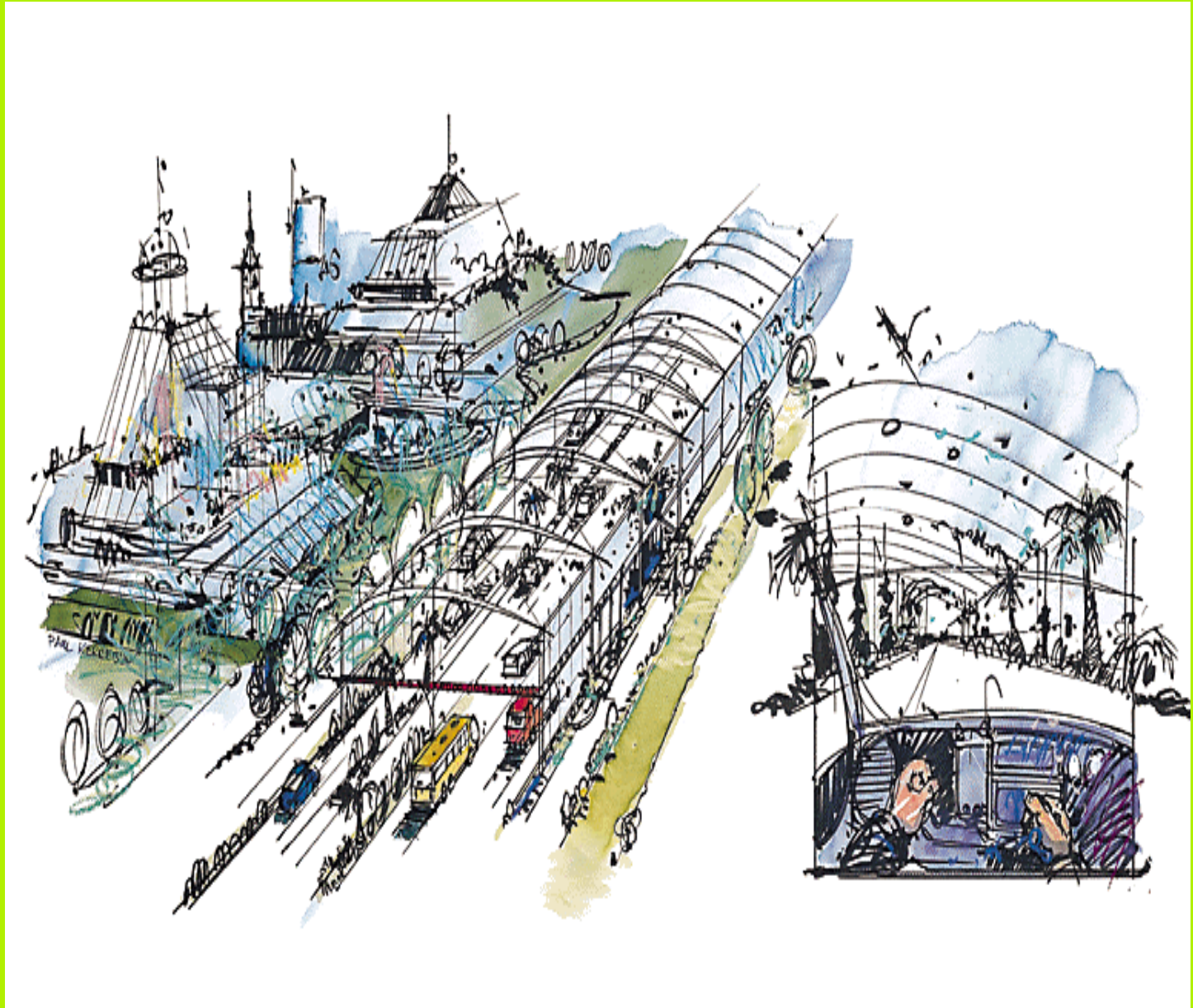



# 10

## Towards greener infrastructure

### REDUCTION OF NUISANCE DUE TO TRAFFIC

#### 10.1 Ecotechnic Road system

Marcello LUMINARI (Autostrade per l'Italia)

*"Nothing great was created in the world without passion" (1770 –1831) Wilhelm Georg Hegel)*

*The love of complexity without reductionism produces art; the love of complexity with reductionism gives rise to science (Edward O. Wilson, 1999)*

*The city is a system of differences. ( 384 a.C.– 322 a.C., Aristotele)*

##### Summary

The impact of the motorway environment, due to either the traffic of existing infrastructure or new construction work, is generally mitigated by the need to comply with statutory obligations and local regulations. Therefore, one of Autostrade per l'Italia's (Autostrade) Research and Developments priorities has been the conceptual definition and development of innovative technological solutions are mainly addressed to the control/abatement of acoustic pollution which are also synergic and consistent with continuously improvements in the Company's overall environmental performance. Some of these studies and researches were developed, implemented and tested on the motorway in urban and suburban traffic conditions, during the European project NR2C, for research on innovative noise mitigating road infrastructures designed to perform different acoustic pollution abatement functions according to different road morphologies such as free fields, embankments and U sections.

Ecotechnic Road Systems (E.R.S.) is a modular concept of nuisance mitigating solutions concerning mainly an appropriate combination and integration of low noise pavement and anti-noise barrier subsystems. These were chosen with a view to the monitoring existing innovative pavements over time and the carrying out studies on the capacities of innovative developed noise reduction devices while taking into account infrastructure type and operating road scenario. The main remedial measures of the acoustic control/abatement solution designed & implemented for the city of Genoa, refer to the implementation of innovative solutions whose development and assessment took place in the framework of the NR2C project.

Low noise pavement and anti-noise barrier subsystems were monitored over time while new ones were developed from feasibility studies, and preliminary and detailed designs for a holistic and full-scale control and abatement of road noise pollution. Others solutions dealing with air and water pollutants control/abatement were studied and developed through the definition of original assessment methodologies and calculation models in order to study the phenomenon scientifically and technically with the use of laboratory prototypes. Feasibility studies were conducted on innovative nuisance mitigating solutions, able to control/abate the road traffic pollutants, and reported in Deliverable D1.4 and some of them (i.e. those to reduce air & water pollution) were initially designed as described in Milestone M1.2 and later detailed in Deliverable D1.5 in terms of specific design & performances parameters updated in Milestone M1.3 including the Technical Data Sheet of the selected innovative solutions useful for the development of the ERS detailed design. The Deliverable D1.6 synthesised the main remedial measures referring to the acoustic control/abatement solutions designed & implemented and the advancements made for the other solutions.

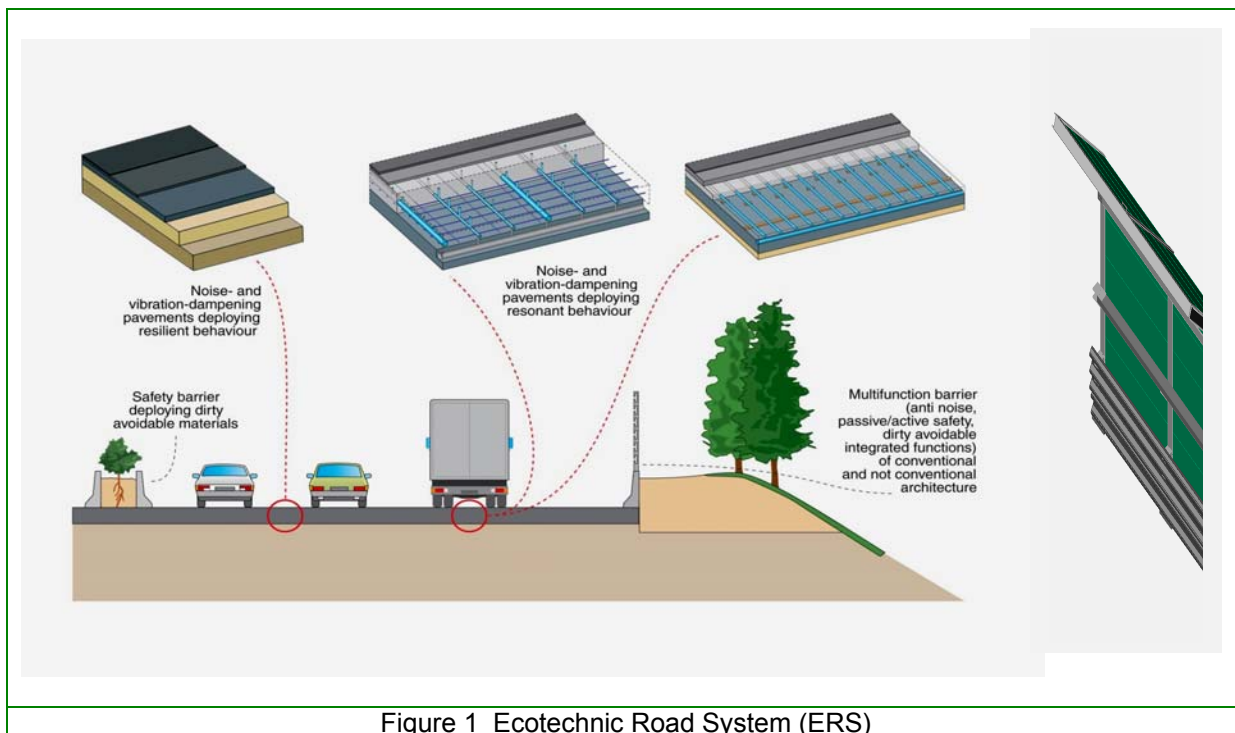

Figure 1 Ecotechnic Road System (ERS)

## 10.1.1 INTRODUCTION

### Sustainable road infrastructures

The road environment that plays a major role as an interface with the natural environment, is tightly conditioned by the resources of the latter. In fact the road environment's impact on the natural environment is considerable on account of the resources it consumes, the land it occupies and transforms, and the disturbances caused as a result of its present and operation.

Therefore the production of a sustainable road infrastructures is a vital need to protect the natural environment. The issue of both environmental or social sustainability has always been of considerable concern to Autostrade per l'Italia S.p.A. (Autostrade) which has developed technologies and practices to deal with them, especially environmental problems. The conceptual definition and set up of innovative solutions for controlling/abating the impact of the road environmental represents one of the goal pursued by Autostrade. which handles about 4 million travellers per day on its network, equivalent to 8% of the Italian population, which is tantamount to "moving a city".

According to NR2C vision 2040, the development of the Ecotechnic Road System by Autostrade represents the provision of sustainable road transport as its contribution towards greener infrastructure. Therefore, the results of NR2C project represent a real strategic contribution for the eco-sustainable development of road transportation infrastructures as concerns urban/suburban areas insofar as it minimises the environmental of the principal nuisances.

### Road Infrastructure and the environment

All projects involving motorway construction and widening are subject to Environmental Impact Assessment (EIA) procedure by Environment Ministry which requires to perform an environmental impact study. For the works underway, environmental monitoring procedures were activated to verify the efficiency of the systems adopted to protect the environment and mitigate impact. Autostrade is committed to evaluating the environmental impact assessment of road works by the careful collection of pertinent data. For example such procedures are in place on the A1 Milan-Naples motorway the new construction of the Apennine section between Bologna and Florence named "Variante di valico" Sasso Marconi - Barberino [www.osservatoriovantedivalico.it](http://www.osservatoriovantedivalico.it) and on widening work for the 3th lane on the urban section between Florence North and South [www.osservatorioterzacorsia.it](http://www.osservatorioterzacorsia.it). Such procedures call for coordination and control on the part of third-party bodies. The principal aims of environmental monitoring are to prevent changes to the environment and report developments in the

environment, based on the use of effective and appreciable indicators to describe phenomena and report risks. All investigative activities are defined and scheduled in terms of three phases: pre- work, work in progress and post- work (first 12 months in operation).

### **Noise legislation & regulation and countermeasure**

In order to avoid the harmful effects of noise exposure from all sources and preserve quiet areas in cities and suburban areas, acoustic mitigation planning and actions are regulated in Italy by legislation complying with the European Noise Directive 2002/49/CE and the Italian D.LGS. 19.8.2005 n. 194 (Implementation of EU Directive). Autostrade, after the completion of the aerial surveys needed to produce the acoustic maps of the bands (250 m in width) adjacent to the motorway network, which are to be protected from traffic noise, defined the critical areas to be protected from the traffic noise, which account for approximately 3 million inhabitants in such bands. The definition of these critical areas was determined by the need not to exceed the limits, measured in LEQ in dB (A). Their definition also led to the drawing up on June 2007 of the "Remedial Acoustic Plan to contain and reduce traffic noise". The Plan (in accordance to the Italian framework law on noise pollution 447/95 concerning acoustic pollution, that referred to road noise by D. M. Environment 29.11.2000 and D.P.R. 30.3.2004 n. 142) was submitted to the 706 Municipalities whose territory is affected by the motorway network. The Company prepared a 15 year programme for acoustic mitigation operations at an estimated cost of 1 billion of euro, which made provision for the installation of 1000 km of anti-noise barriers, with an absorbing surface of approximately 4 million m<sup>2</sup>, noises absorbers at tunnels entry and exit, special insulating windows, 16 km of acoustic covers & tunnels and anti-noise pavements. The acoustic remedial plan presents the countermeasures priorities including the Genoa city for which have been forecast 16 operation/project to be carried out to protect 133.000 involved inhabitants through 434.209 m<sup>2</sup> of porous asphalt pavement, 186.000 m<sup>2</sup> of noise barriers and acoustic tunnels, 154 m<sup>2</sup> noise protection windows and fan-coil system. The main remedial measures of acoustic control/abatement designed & implemented for the city of Genoa, refer to the implementation of innovative solutions which, including their assessment, were carried out in the context of the NR2C project.

### **Air quality control**

It should be pointed out that the responsibility for emissions to air produced by the vehicles on the road network does not lie directly with the road operators, as they are mainly responsible for infrastructure management including the traffic monitoring, but have no control over vehicle performance. Current legislation to reduce road traffic air pollution only addresses to vehicles and fuels. The Commission (EC, 2006b) has predicted that increases in the activities of heavy goods vehicles will continue to drive CO<sub>2</sub> emissions upwards, despite the expected improvements in efficiency within the sector due to more stringent limits on vehicle emissions. Moreover passenger transport continues to grow. Increased car usage and the limited number of passengers per car offset the improvements gained from improvements in vehicle efficiency. However, road transport-related emissions are not limited to CO<sub>2</sub> and NO<sub>x</sub> as particulates and vapours are also released directly into the atmosphere by, for example, to tyre/road/brake dust whose output is directly related to real-time traffic and ambient meteorological conditions. Despite our incomplete knowledge of PM<sub>10</sub> diffusion and the difficulties in their measurement, recent studies seem to show that the major areas responsible for the critical situation of PM<sub>10</sub> are urban and industrial zones and in order to control/abate them, but the countermeasures introduced by the local government authorities are more or less ineffective in controlling such emissions due to the transregional aspect of the phenomenon (pollutants dispersion and transport). The complexity of the PM<sub>10</sub> data analysis requires an integrated approach, which combines the monitoring results with an emissions database, dispersion patterns and data on weather and climate-related to the area under evaluation.

Autostrade is involved on this item analysing, through modelling, the air quality in tunnel and in U section optimising the design and the operating of existing air conditioning plant and increasing the traffic outflow conditions in order to avoid the slow and discontinuous outflow which generates more elevated productions of air polluting agents due to the fact that the air quality in proximity of the trafficked road is not only linked to the vehicle type daily passages but mainly to the traffic outflow conditions. Taking into account this approach, the emissions produced by vehicles travelling along its network are reduced also through road widening work and the automated toll collection stations (using a toll collecting system such as Telepass) as well as a system for average speed monitoring and automatic speeding fines (using a system such as Tutor). In addition, Autostrade is committed to cooperating with institutions (i.e agreement with the association of municipal authorities to promote the use of low environmental impact fuels) in order to improve air quality.

## Road water quality control

The flash flood washing of the road surfaces, other than the traffic accidents involving the spillage of dangerous substances, can influence the roadside environment as the ground water quality is impaired as a result of rainfall runoffs onto the exposed carriageway. Usually the stormwater that initially runs off a road carriageway is called the 'first flush'.

Italian law on pollution produced by motorway surface run-off (including first flush) waters is set forth in legislative decree 11 May 1999 n°. 152, as amended and supplemented by legislative decree of 18 August n° 258 and legislative decree of 3 April 2006 n° 152. In general terms, meteoric run-off waters are not considered "waste water" pursuant to article 1 letter bb of legislative decree 152/99. Article 39 of the foregoing legislative decree, moreover, lays down that "...the Regions shall regulate: b) the cases in which the intake of run-off waters can be .....required to undergo special types of treatment, art.39 subsection 1, and that "...the cases in which can be demanded... are conveyed and opportunely dealt", article 39, subsection 3. The legal framework operating at regional level is still incomplete. Emilia Romagna is, so far, the only region to pass legislation to implement article 39 of legislative decree 11 May, n° 152, with the resolution of the regional council dated 14 February 2005 n° 286. This regional law also regulates cases in which "the intake of meteoric run-off waters from other and separate outlet channels" must be subject to special regulative treatment. As concerns new projects, reference must be made to the specific regulatory requirements contained in the environmental impact analysis whereby for completed projects or those under construction the provinces are required to set up and maintain a works archive.

To optimise the countermeasure able to control interferences between road & water bodies were improved using infiltration and subdispersion systems included in the controlled points for the selective disposal of deposits installed in water-drainage closed systems. The relevant role of the pavement in surface water flow control (transportation & temporary storage) through lamination and first flush catchments were analysed, by monitoring of the flash flood washing, for the porous pavement in terms of peak flow reduction & discharge delay and water quality. Two approaches were considered to define an interception system. one was the reservoir pavement, approached through the achieved results analysis, and the other was a special multifunctional precast culvert.

### 10.1.2 SCIENTIFIC AND TECHNICAL APPROACH

Restating the introductory observations, the impact of the motorway environment due either to the traffic on existing infrastructures or new construction work, is usually mitigated as a result of the need to comply with statutory law or local regulations. Therefore, one of Autostrade Research and Developments priorities has been the conceptual definition and development of innovative technological solutions mainly addressed to the control and abatement of acoustic pollution, which are also synergic and consistent with improvements in the Company's overall performance. Some of these studies and researches were developed, implemented and tested on the motorway in urban and suburban traffic conditions, during the European project N.R.2C., for research on innovative noise mitigating road infrastructures designed to perform different acoustic pollution abatement functions according to different road morphologies such as free fields, embankments and cuttings.

In order to achieve the project's objectives, a research process implemented to investigate a nuisance mitigating infrastructure to control/abate road traffic noise & vibration pollution (and for the air and water pollution pertinent to road infrastructures) is based on the following steps: phenomena modelling, concept definition, small & full scale design, and construction & testing. In particular innovative and advanced new subsystems and system solutions were set up on the basis of models and laboratory tests, to verify the efficiency of the new concepts and orient the consequent detail design developments. Some of them such as the air cleaning system has been realised and characterised at full scale. The different tests made under simulated real-life traffic conditions on the mock-up and prototype made it possible to define the process and design parameters and the system performances and features to assess the technical and economical feasibility for a possible use on a real traffic condition site. The constraints regarding maintenance and energy savings, necessitates a reappraisal of the project in terms of sourcing requirement before its implementation can be achieved.

Over all in the holistic approach in terms of noise abatement regarding noise generation, propagation and reception, has been considered at nuisance mitigating infrastructure level combining and/or integrating performance of low noise pavement and anti-noise barriers.

Some existing innovative full scale low noise pavement solutions were monitored on real traffic conditions on long length road sections, together with their reference surfaces (traditional porous asphalt, traditional dense bitumen), in to test the different solutions

All through the process, measurements were performed in order to check and validate the models, compare the possible solutions, evaluate the full scale prototypes and finally control the definite solutions implemented in real conditions. The theoretical models, after development and improvement to increase knowledge of tyre/road noise generation, road absorption characteristics and overall vehicle emissions, enabled us to verify the acoustic efficiency of the new pavement concepts and guide future developments.

### **10.1.3 CONCEPT AND FUNCTIONAL SYSTEM DESCRIPTION**

Autostrade's innovative concept of the Ecotechnic Road System (ERS) is defined as an original and appropriate combination & integration of nuisance mitigating subsystem solutions developed at prototype level as road pavement (resilient and resonant and reservoir types), barriers (anti-noise, safety and dirty avoid type) and auxiliary subsystems (air cleaning and first flush water control type) based on innovative concepts, materials, technologies and processes in order to control/abate air, water, noise & vibration pollutions complying with driver safety requirements. To identify and combine different technical solutions selection & design criteria were set up that met environment needs and user requirements. The innovative nuisance mitigating solutions, initially conceived and designed to reduce air & water pollution, noise and vibrations in the infrastructure configuration (free field, viaduct/tunnel, embankment and U sections including a false cutting in urban and rural/suburban area), were implemented as a pilot case study for noise and vibrations on urban and suburban roads. The functional and operational requirements of the innovative Ecotechnic Road Systems (ERS) conceived by Autostrade as a combination of the nuisance mitigating subsystem solutions were derived from the performance of each subsystems and based on environment protection needs. To select these components and assess the performance of the foregoing solutions a methodology based on environmental indicators was proposed that take account of their capacity to abate pollutants while taking into account infrastructure typology and the operating road scenario.

The Ecotechnic Road System through the integration of different devices, structural elements and equipments permits to achieve a global cost optimisation and efficiency on the eco-compatibility. The technical data sheet of the selected innovative solutions (included in M1.3 with their design parameters which were useful for the development of the ERS detailed design described in the deliverable D1.6) refers to the following items: nuisance mitigating infrastructure, pavements (low noise and anti-vibration and water reservoir and filtering pavements), road barriers (various innovative multifunctional noise reduction devices), auxiliary systems (air cleaning system unit and multifunctional prefabricated concrete culvert as water polluted control systems). The assessment of the performances of these solutions from an acoustical, mechanical, chemical and physical point of view was conducted through the analysis of the results concerning laboratory and on site tests. These tests were performed on the following nuisance and mitigating solutions.

### **10.1.4 SOLUTIONS - PAVEMENTS (LOW NOISE AND ANTIVIBRATING TYPE)**

It is recognized that quiet pavement solutions develop effective noise-controlling pavements by concentrating on sound absorbing properties and texture characteristics. Under the N.R.2C. project performance was analysed by monitoring the experimental pavements using resilient and resonant technology to control low-frequency noise and implemented during the European SIRUUS (Silent Roads for Urban and Extra-Urban Use) project on Autostrade motorway network. The concepts were implemented on the A1 (Milan-Naples) in October 2001 (slow lane) and in June 2002 (fast & overtaking lanes) in the form of different solutions leading to a decrease in road noise levels of more than respectively 3dB(A) and 5dB(A) in comparison with a traditional porous asphalt and dense bituminous surface.

Bituminous double layers (resilient behaviour) by micro porous asphalt wearing course (20mm thickness, 0-5mm basaltic aggregate size) and porous asphalt base course (40mm, 0-25mm limestone) on bitumen modified membrane interlayer as vibration absorbing.

Bituminous multi-layers (resilient behaviour) which includes other than double layers also a bituminous semidense road base (150mm, 0-25mm limestone and lightweight) to reduce the mechanical impedance.

Euphonic composite multilayer (resonant behaviour) by double porous layer -including micro porous asphalt wearing course (20mm, 0-5mm basaltic) and porous asphalt base course (40mm, 0-25mm limestone)- connected by neck to a layer with a Helmholtz resonators system designed to absorb noise in the range from 100 to 250 Hz obtained from an embedded sound absorptive localised tube cavities included in a continuously reinforced concrete slab (350mm, 0-25mm limestone).

Ecotechnic composite multilayer (resonant behaviour) by double porous layer -including a micro porous asphalt wearing course (20mm, 0-5mm basaltic) and porous asphalt base course (80mm, 0-30mm limestone)- connected to a layer with an embedded Helmholtz resonators system as above indicated designed to absorb noise in the range from 100 to 250 Hz obtained from sound absorptive localised tube cavities included in a diffusive microporous cement mortar layer (100mm, 0-6mm lightweight) as a transition layer with the bottom on site cold recycled layer on the on site stabilised foam bitumen with cement mixture.

The noise mitigating pavement alternative solutions were useful also to define the concept of specialising pavement lanes in terms of low road-tyre noise through uniform superficial layer with different under-layers pavement. In fact the traffic composition in terms of light and heavy freight vehicle percentages plays an important role in defining the pavement type for purposes of optimising noise control/abatement efficacy and maintenance needs (heavy goods with limited speed on slow lane, cars with high speed on overtaking lane and mixed conditions on speed lane).

A porous asphalt mixture variant to reduce the noise emission (30mm, 0-12mm basaltic, i.e. 5-10mm & 7-12mm basaltic and limestone filler) were produced for echo-draining single layer suburban&urban pavement presenting an outflow rate value  $>20 \text{ dm}^3/\text{m}$  (cilinder  $H=154\text{mm}$  and  $\varnothing=250\text{mm}$ ) and a frequency dependence of sound absorption coefficient with two peak (at 650 and 2000 Hz, with  $\alpha>0.40$ ) increasing these values at low frequencies, texture (HS) and durability in comparison to the micro porous asphalt layer.

#### **Surface, structural and acoustic monitoring**

The surface (semester surveys of adherence, texture, evenness & superficial damages), structural performance (data & information collected during the operation) and acoustic (SPB tests) of these innovative noise mitigating solutions were monitored over time for near 6 years after his construction. The evaluation were performed to define the needs for further development regarding also the precasting approach in order to reduce the maintenance constraints installing these pavements.

Surface & structural – Evenness (IRI), skid resistance (SFC) and texture (HS) were always in Autostrade internal tender technical specifications range ( $\text{IRI}< 1,8 \text{ mm/m}$ ,  $\text{SFC}/100>53$ ).

The surface damages and cracking monitoring pointed out that for the euphonic pavement, the 2,5m resonant system module length (composed by steel pipes respectively 2 of  $\varnothing=80\text{mm}$  and 4 of  $\varnothing=40\text{mm}$ ) is almost equal to 2,4 m average cracking distance and the two peaks in the frequency distribution of the cracking correspond to a two interval between 1.5 and 2.0m or between 3.0 and 3.5m, which are the almost the multiple, 1,5 m and 3,0 m, of the distance between 2  $\varnothing= 80 \text{ mm}$  pipes..

Acoustic - Compared to the reference porous pavement, the euphonic pavement on 2002 gained 2-4 dB(A) in 80-250 Hz, 8-14 dB(A) in 315-800 Hz and 2-6 dB(A) in 800-5000 Hz. All solutions on 2006 acoustical monitoring, after 71x106 passages of with 22% heavy vehicles and 36000 passages as AADThf), show a gain of 7,0-2.2 dB(A) (from SPBI ranging from 76.5 to 80.3 dB(A) in comparison to the reference porous asphalt pavement ranging from 82.5 to 83.5 dB(A) (50 mm, 0/16 mm) laid contemporarily to the innovative solutions and performing a CAT equal to 0,51, texture as 1,01 and an IRI of 1,70 (values obtained from first semester 2006 survey) to all the motorway speeds (range 70-120 km/h) and for all the vehicles categories.

#### **Structural modelling**

Structural behaviour of the solutions were modelled by FEM to assess performances and possible evolutions. The 6 years euphonic monitoring at full scale confirms the simulation results from the original FEM model. For the ecotechnic type, the original FEM model of disconnection steel sheet innovative panel, pointed out the excessive deflection of shaped sheets which require higher values of their thickness, to avoid panel fatigue damaging and upper bituminous layer deformation, or changing geometry or materials.

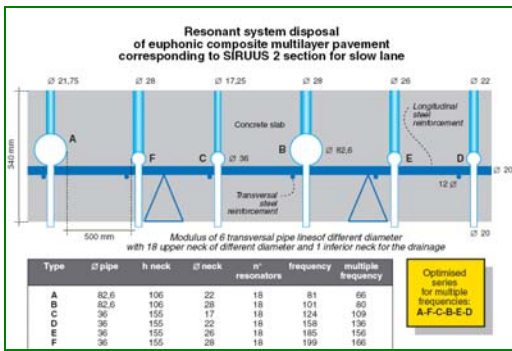

Figure 2 resonant system for euphonic pavement



Figure 3 concrete slab of euphonic pavement

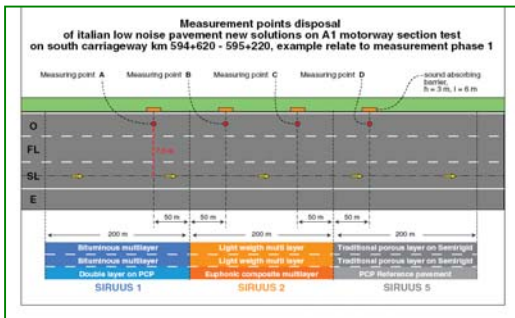

Figure 4 low noise solutions location and SPB

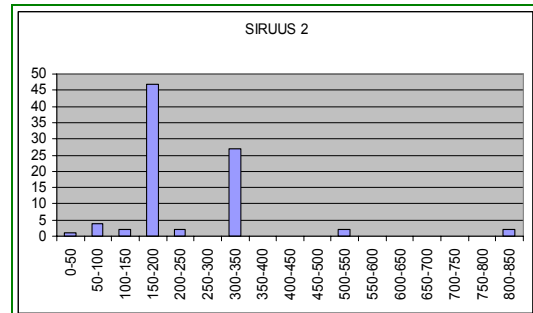

Figure 5 CRC slab transversal cracking monitoring

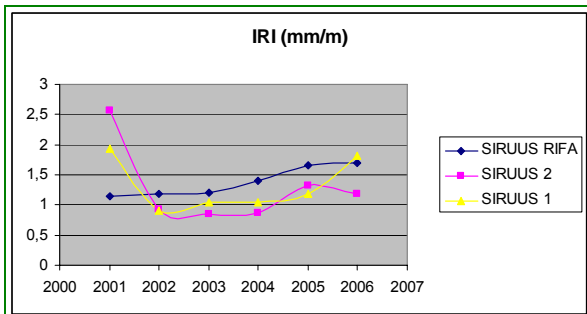

Figure 6 IRI monitoring (slow lane sol. 2 is euphonic)

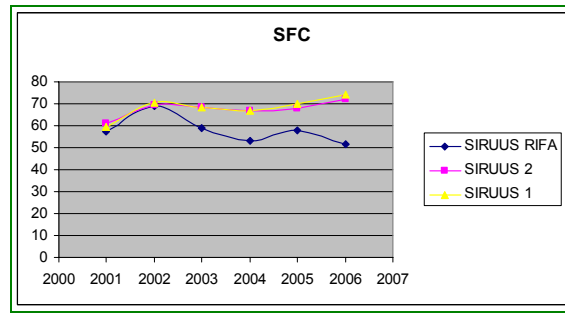

Figure 7 SFC monitoring (slow lane sol. 2 euphonic)

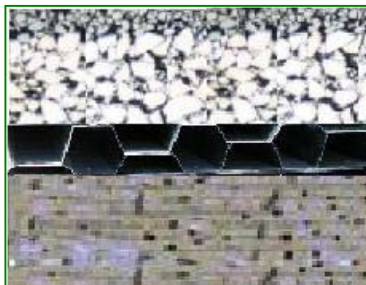

Figure 8 Cross section of eco-technic solution

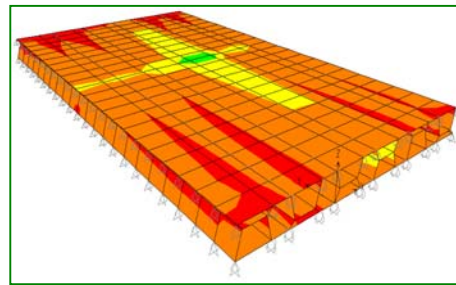

Figure 9 Structural modelling of eco-technic solution

## Possible developments

New design concepts to industrialise the infrastructure construction could be supported by modular manufacturing of multi-function structures and factory-constructed pavements elements. These last will be achieved developing new materials as self monitored permitting the layer function separation. Modularity for road infrastructure, based on ITS, is required to reduce the work impact on traffic for quickly installation during night time. The integration of prefabricated subsystems are needed to product efficient traffic noise and operation&management control functions. The pavement conditions will be continuously monitored through intelligent components&instruments facilitating the performances data&information processing and integrating into an expert maintenance and management system.

### 10.1.5 SOLUTIONS - PAVEMENTS (WATER RESERVOIR AND FILTERING PAVEMENT TYPE)

Due to his infiltration effect, the porous asphalt can substantially reduce the quantity of a large number of pollutants found in road runoff. The first flush road runoff water pollution were assess, updating a previous measurement campaign, after their collection at full scale on motorway sections on operation presenting two porous pavements, draining and eco-draining types, continuing a preceding study and focusing to define a more practical solution for water collection and processing subsystems. These solutions can be incorporated into the concept of a modular pavement or auxiliary systems for the roadside implemented in a simplified industrialised construction approach. The improvement of previous solution were pursued contributing to reduce the costs of the existing countermeasure to control interferences between road and water bodies for first flush road runoff water pollution and, possibly, traffic accidents involving dangerous liquid spillage (even if the statistical incidence of these last to produce an environmental damage is irrelevant due also to the preventive and management emergency procedure and actions of road operators).

For hydrologic and hydraulic characterization of the artificial basin contributor from recorded precipitation events data at two experimental monitoring sites,, will be defined the lag-times to the precipitations of the artificial reservoir and the total capacity of outflow impoundment-lamination (water overflow). On the basis on rainfall data (from pluviometer) and on flow rate (from a piezoresistant probe), the porous asphalt exhibit a delay time (lag) and the capacity to absorb small rainfall, from 5 to 15 mm of rain (outflow coefficient of the first phases of the event 0,4-0,5, reduced to 0,2-0,3 if the outflow volume is not enough to saturate the layer). While if the event exceeds a certain threshold or a certain series of successive events the reaction will be immediate in so far as the draining mixture will be saturated (0,7-0,85 as outflow coefficient of the remaining phases of the event). In the second case with a higher flow rate the pollutant loads will be more diluted. The pores are only cleaned when one medium-to-intense rainfall event takes place (roughly above 5 mm/h).

Concerning to the water sampling chemical analysis, the concentration data decrease comparing the first flush waters and the successive meteoric events samples. The metal concentrations deriving from the water samples collected on two monitoring sites are in compliance with the national regulation limits regarding the standard quality of the surface water (D.lgs. 03.04.06/152). Metal concentration growing on the section subjected to a snow precipitations. Lead values are still presents, notwithstanding the use of green gasoline, slightly greater in one of two site. Chromium and nickel are present in low concentrations on both sites monitored. Copper and zinc metals are present in greater concentrations, instead of Cadmium concentrations which were above the detection limit in water samples. PAHs were always less than of the instrumental detecting threshold as the metals rhodium, platinum and palladium, major components of industrial catalytic systems. Each sampling cycle presents a mineral oil concentration relatively constant. Among the various events were still observed differences in the concentration of one or even two orders of magnitude. The dynamics of transport and disposal of the oil on the roadway surfaces would seem therefore be characterized by a certain slowness regardless of the amount initially present. There was no differentiation between specific analysis on the fraction of solid samples of the first flush water and those taken later. For them also, because of limited quantities analysed, it was also necessary to make some analytical extrapolation to compute the final concentration. The data on particulates (suspended solids) based upon the filtration analysis did not return high values (i.e. in terms milligrams or generous extrapolations). The suspended solids analysis put in evidence the presence of different types of PAHs investigated. The mineral oil and heavy metals have been fairly relevant; the mineral oils present the concentrations in

the order of thousands of mg/kg. Similarly to the water analysis results, also on the particulates no rhodium, platinum and palladium were detected. Measured particulates concentrations are comparable with the results of the analysis carried out on the samples detected on the bottom of sewer ducts of some highly humanized and polluted area, while by average they are an order of magnitude higher comparing to the results of the analysis carried out on particulates of natural stream. Simplified solution were proposed constituted by lightweight porous asphalt/concrete mixtures of a residual void content that decreases from the upper surface, and also made from unbounded lightweight artificial aggregates treated for the selective absorption of oily substances and wide-gauge polyester geo-grids for load sharing. The hydraulic flow of this solution [x length=20m, y width=2m, z depth=0,25m] has been simulated by means of numerical model based on the code of calculation MODFLOW (U.S. Geological Survey). Were considered porous asphalt (z=0,04 m, K = 9,8\*10<sup>-4</sup> m/s, effective porosity ne= 0,15÷0,18) on lightweight porous asphalt (z=0.20m, 7-15mm, Rc> 45 kg/cm<sup>2</sup>, K = 2.2\*10<sup>-3</sup> m/s, ne = 0.15÷0.18). Three vertical draining septa of 0,15 m height are inserted to slow down the phase of reservoir pavement emptying to the end of the possible event of spill off and infiltration. The modelling has characterised the solution by a retention time which can vary from few hours to some days also depending upon the event type, precipitation intensity and type of dangerous discharged liquid type. The collection system characteristics studied for the reservoir pavement can guarantee the average pollutants abatement up to 50%.

During the structural revision of the reservoir pavement, it was also to identify an other approach to simplify the storage base and pavement by using a multifunctional prefabricated concrete culvert filled with material suitable for pollutant multipurpose treatments and recyclable (with prevalent polar surface activity hydro repellent and oil substance attracting) as water polluted control systems for standard protection.

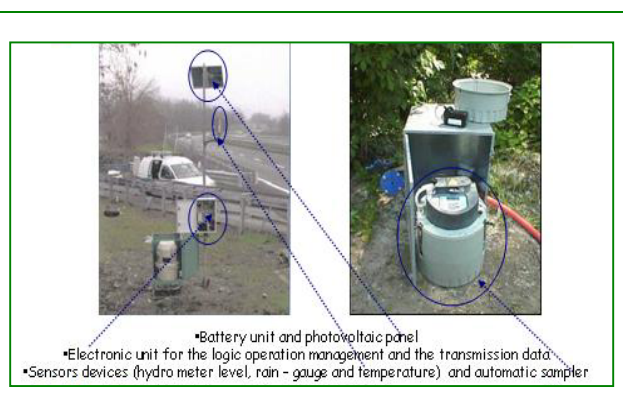

Figure 10 Water pollutant monitoring system instrumentation on motorway A7



Figure 11 Water pollutant monitoring system instrumentation details on motorway A7

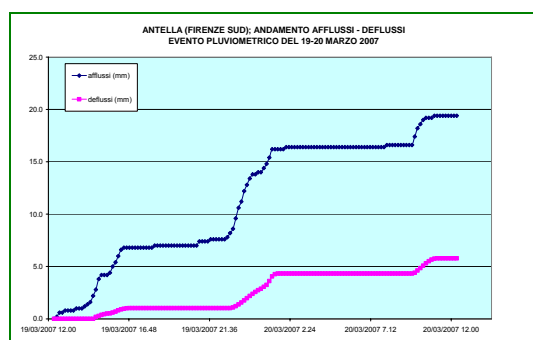
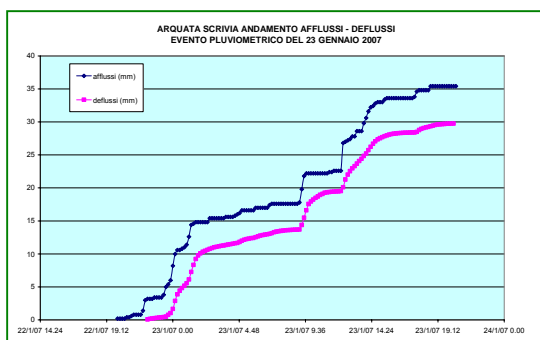

Fig. 12 and fig. 13 Comparison of the inflow & outflow volumes during a precipitation event (left A7, right A1)

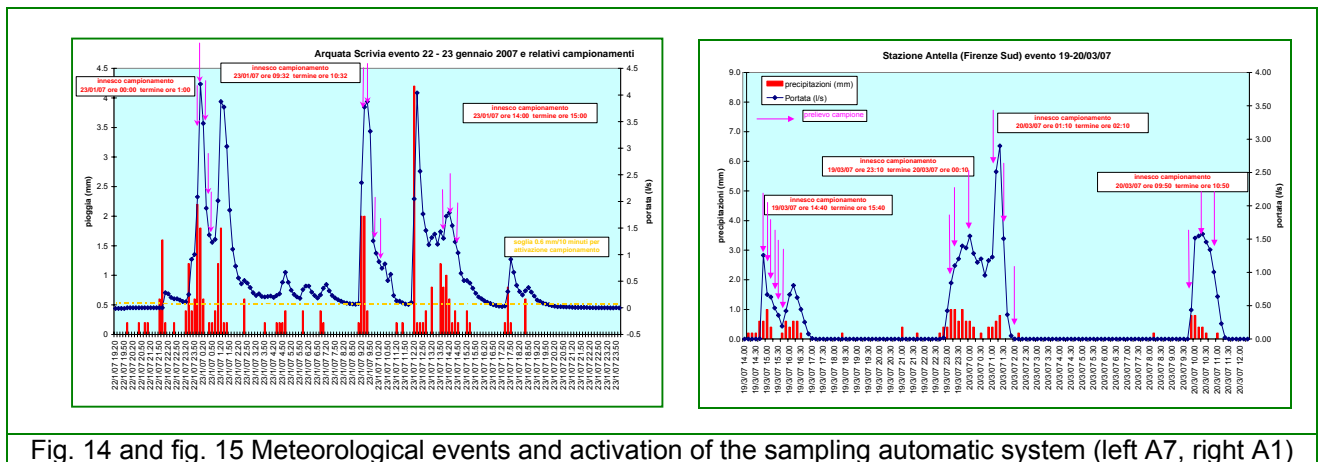

Fig. 14 and fig. 15 Meteorological events and activation of the sampling automatic system (left A7, right A1)

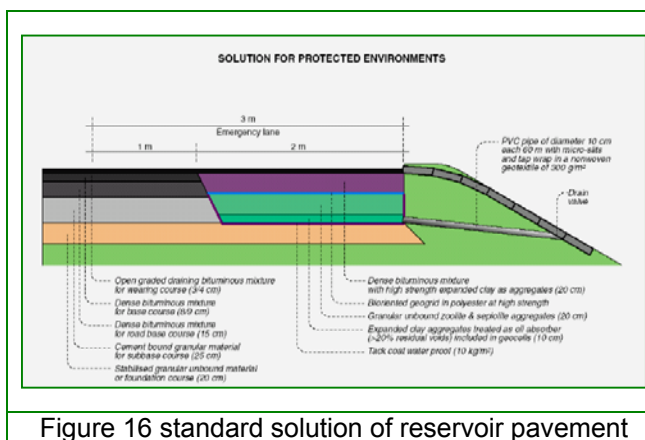

Figure 16 standard solution of reservoir pavement

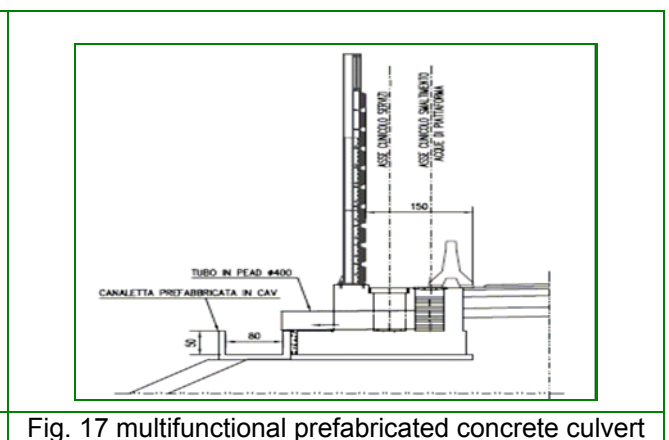

Fig. 17 multifunctional prefabricated concrete culvert

### 10.1.6 SOLUTIONS - ROAD BARRIERS

Traditionally, passive means as physical barriers to attenuate road traffic noise were employed. Due to their cost ineffective contribution to lower frequency noise abatement (to achieve significant reduction the barriers have to be rather bulky) were developed the low noise pavement solution above mentioned.

The research approach for the road barriers were concentrated to the U section configuration which is obtained when  $L \leq 2H$  and where  $L$  is the carriageway width and  $H$  is the height of buildings or obstacles, as dunes, walls, cuttings, in front of the infrastructure. The U shape determines high acoustic pollution levels in correspondence of all the receptors due to the semi-diffuse sound field (multiple reflections of sound rays), but also some acoustic pollution self-protection conditions as consequence of the diffraction increasing of the higher edges (sound absorbing coverings) or reducing (high reflecting lateral surfaces for multiple reflections).

On the basis of the U section acoustical definition and to solve existing infrastructure constraints in bridge and embankments, the development of innovative barrier solutions for U shaped road section were principally targeted at coupling the traditional barrier/cover types as antinoise, eventually coated with dirt-resistant products, and restrain integrated road safety system (deploying a New Jersey concrete profile road restraint system including if necessary resonator systems or a steel barrier). The advantages of the multifunctional barrier conceived by integrating horizontal noise-absorbing steel elements & concrete or steel safety supports are compatibility and integrability with existing anti-noise barriers, freeing valuable space by combining safety and anti-noise barriers, increasing the efficiency of the lateral carriageway/lane space, improving anti-noise performance and cost reduction.

New concepts were also proposed as the improvement of the structural and acoustical performance characteristics through new materials or structural types with the optimisation of noise absorbing properties.

In a U-profile segment, as stated, semi-diffuse conditions prevail in the acoustic field on account of multiple-reflections. Moreover, the noise absorption properties of the air and the most common "natural" materials in the road infrastructural environment and its appurtenances (asphalt, paint, earth, grass and vegetation) exhibit significant acoustic absorption coefficients for high frequencies (from 1000 to 4000 Hz). As a result in U-profile segments the typical noise spectrum for the receptors in the vicinity is modified, and generally frequencies between 400 and 1600 Hz prevail. In such conditions the characteristics of the sound-absorbing materials used must be adjusted to counter these lower frequency tones and, in general, this is obtained by increasing the width of the materials used, with a consequent increase in costs.

Innovative anti-noise panels can be made with the use of a) thinner layers of sound-absorbing materials ( 10 ÷ 15 mm) but constructed to a higher density (2000 ÷ 3000 gr/m<sup>3</sup>) and with the insertion of air spacing ( between the back ) panel, the sound-insulation material and the porous material) with a width amounting to ¼ of the wave-length of the lowest frequency to attenuate (in our case 400 ÷ 500 Hz), b) the use of waterproof film, plastics or glass fiber placed in front of the porous material but separate from it. This system may also represent a favorable element in atmospheric pollution control (see following paragraph) and c) the deployment of resonators, usually Helmholtz of ¼ the wavelength. These innovative techniques can be used not only for lining the walls of U-profile road segments but also for the production of anti-noise panels to be placed at the top of dunes or trenches.

New concepts were also proposed adding new functions as air protection and traffic management and info-mobility performances by smart sensors and a self-standing photovoltaic system, including tertiary safety of prevention and signalling and sanctions to deterrent behaviour, by the active integration into the road infrastructure of limited environmental impact and improved road traffic safety.

The innovative noise reduction devices/systems considered were

- Multifunction barrier called INTAUT (anti noise and passive safety integrated functions) of conventional architecture (horizontal elements noise absorbing and concrete safety support);
- Reclining multifunction barrier (anti noise, passive safety and maintenance active integrated functions) of conventional architecture (horizontal elements noise absorbing and steel safety support);
- Multifunction barrier (integrated anti-noise, passive safety, air filtering and dirt resistant functions) of unconventional architecture (noise absorbing lightweight concrete vertical elements and concrete support);
- Multifunction barrier (integrated anti-noise, passive safety, air filtering and dirt resistant functions) of unconventional architecture steel noise absorbing vertical elements filled with expanded clays or active carbons aggregates;
- Multifunction barrier (integrated anti-noise, passive safety, air filtering and dirt resistant functions) of unconventional architecture (integrated anti noise tunnel or baffles);
- Multifunction barrier (integrated anti-noise, passive safety, air filtering and dirt resistant functions) of unconventional architecture.

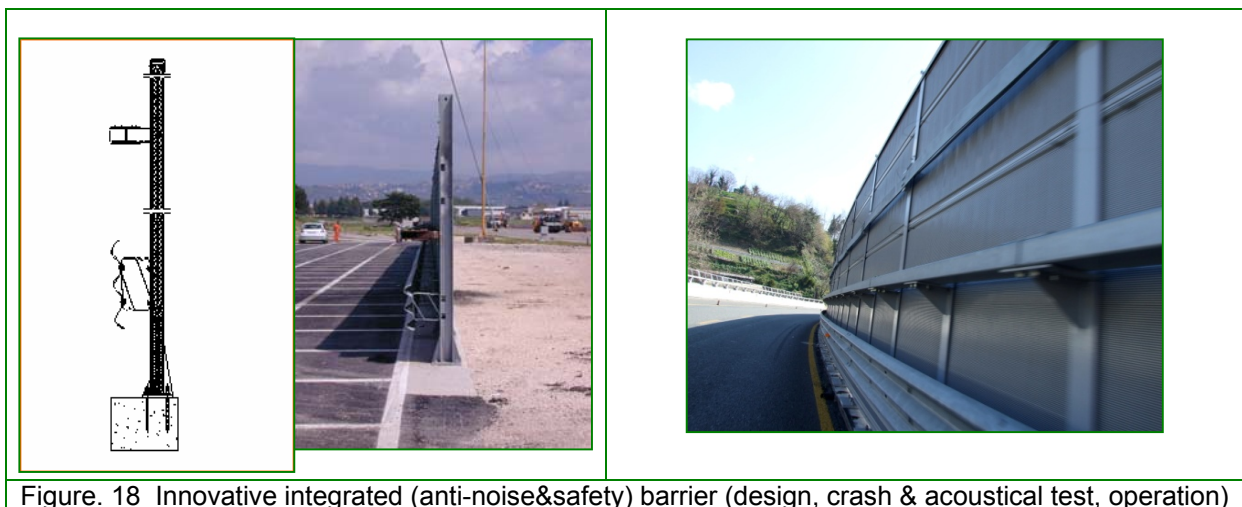

Figure. 18 Innovative integrated (anti-noise&safety) barrier (design, crash & acoustical test, operation)

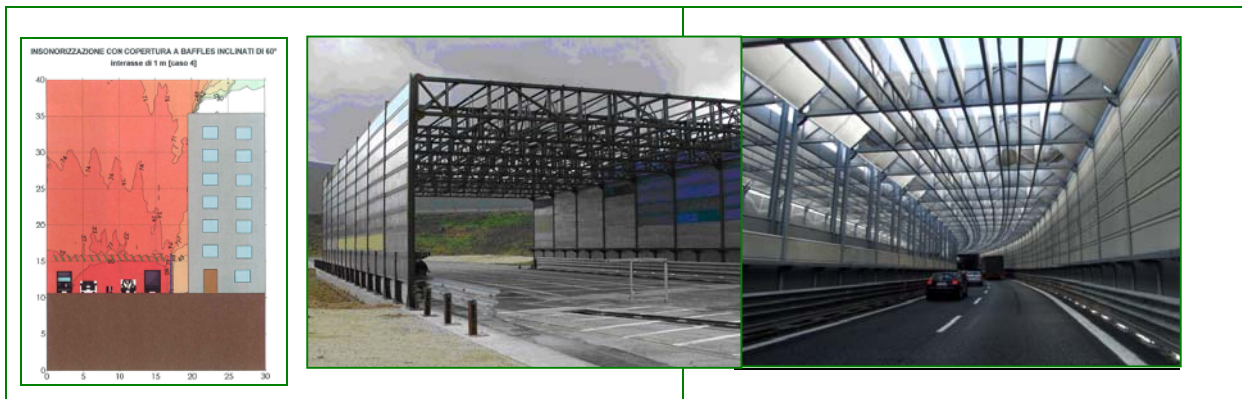

Figure 19 Innovative integrated covers (acoustical modeling, crash & acoustical, operation)

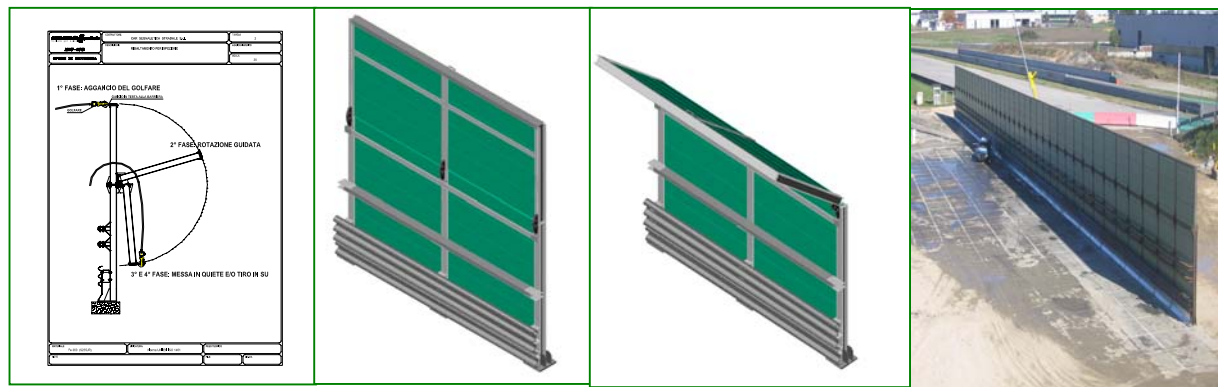

Figure 20 Innovative integrated reclining barrier (from design to crash & acoustic tests)

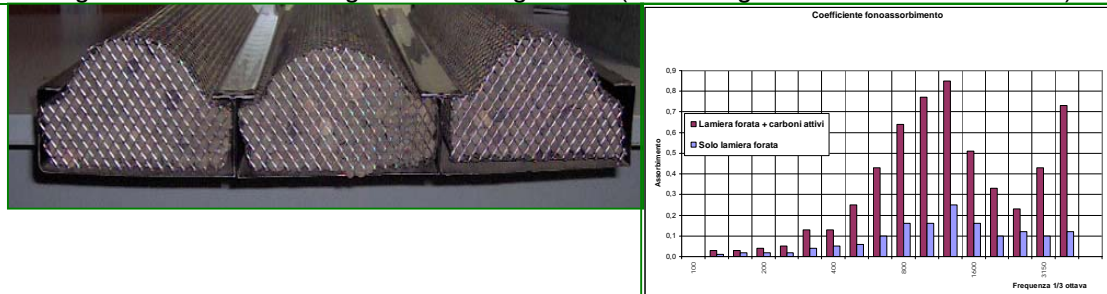

Fig. 21 Innovative barrier prototype and sound absorption test results on new material for anti noise barriers

Autostrade were experimenting the use of titanium dioxide (TiO<sub>2</sub>), a composite dirty resistant and able also to reduce some air pollutants, when incorporated in paints or mortar. Experimental full scale trial were carried out on the A1 motorway between Scandicci and the link with the A11 Florence-Pisa-Livorno, where a double row of Jersey barriers on the central reservation were treated with TiO<sub>2</sub> paint.

### 10.1.7 MODELLING CASE STUDIES - TRAFFIC NOISE POLLUTION

The acoustic performances of noise abatement solutions including innovative pavements & noise reduction devices were analysed & assessed from an acoustical global point of view with an existing ray tracing model for traffic noise propagation prediction, an overall noise reduction optimisation and prediction studies. The holistic noise approach that considers the entire vehicle & infrastructure system and addresses annoyance aspects was carried out through the simulations performed using Italian motorway noise database with the reference conditions as the road infrastructure embankment configuration in motorway, suburban & urban areas and U section configuration in urban areas in relation to the building positions, and also taking account traffic composition & conditions (as speed & flow rates). Different solutions are available in order to reduce noise nuisance by road pavement

design, between 3 dBA to 6 dBA, via noise reduction devices, up to 8 dBA, and via cumulative contribution or optimised solutions for up to 12 dBA.

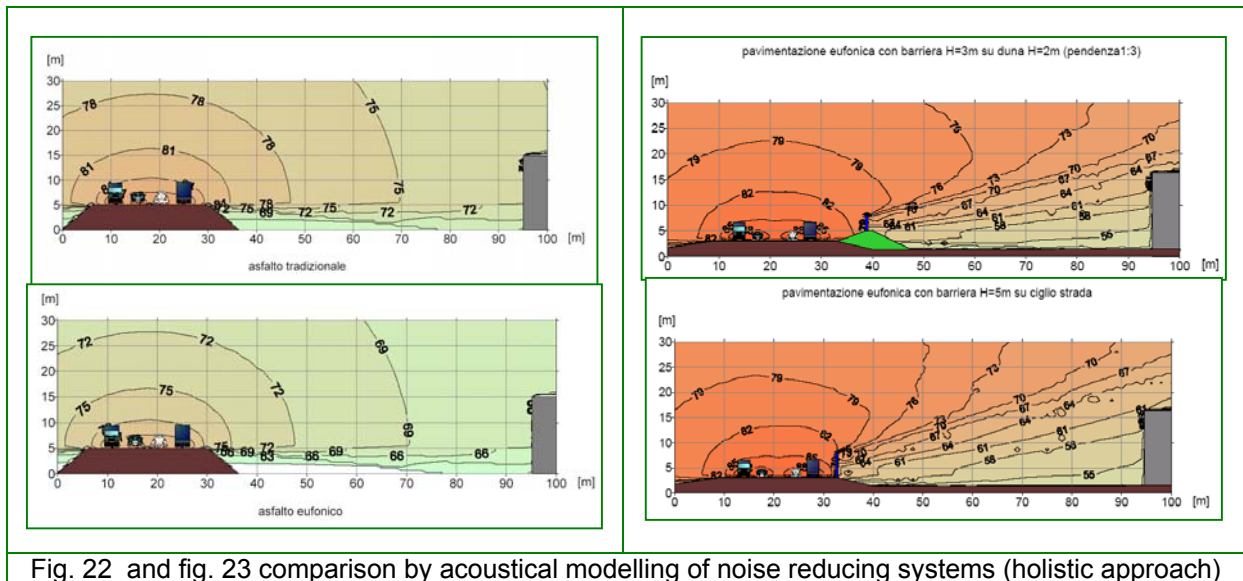

Fig. 22 and fig. 23 comparison by acoustical modelling of noise reducing systems (holistic approach)

### 10.1.8 MODELLING CASE STUDIES - AIR QUALITY

The air quality were approached analysing the volumes of a road tunnel (including the tunnel exits affected by the plume effect) and of a rural and urban road U shape sections, by an original numerical simulation model. This model was developed by taking into account the fluid-dynamic effect of road-vehicle motion in order to carry out the map of atmospheric pollutant concentrations within the foregoing volumes in near-to-real conditions. The analysis was extended to various types of U shape road sections (cuttings, false cuttings, canyons) and positions of the surrounding land and took account of the variation in meteoric ventilation. With the use of an innovative CFM method (Control Function Method) an objective measure of the environmental impact of road traffic for the foregoing volumes was obtained. The possible introduction of air-cleaning active systems in the tunnel and at the exits was considered. Considering the results presented in the form of a map of CO concentrations for the cases investigated, with and without the air cleaning subsystem unit, a significant reduction in environmental impact were estimated by the use of the Control Function varying from 4 % to 19 % with an average value of 9 % in the case of U section (embankments with false cutting and barriers) and from 6 % to 12 % with an average value of 8 % for a cutting section under all the analysed conditions (traffic, wind and presence/absence of barriers),

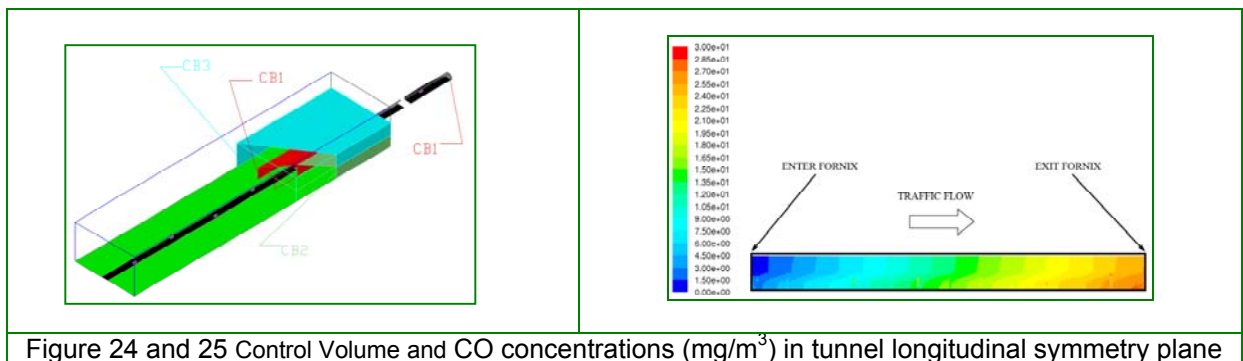

Figure 24 and 25 Control Volume and CO concentrations ( $\text{mg}/\text{m}^3$ ) in tunnel longitudinal symmetry plane

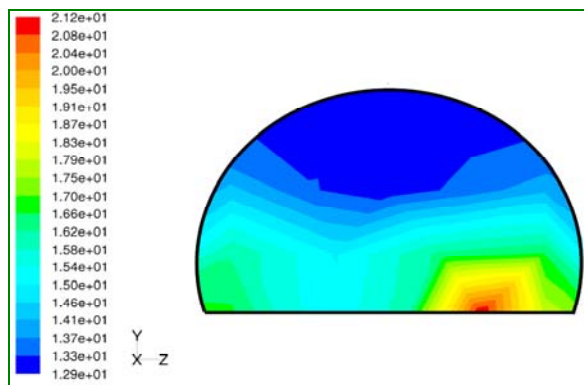

Figure 26 Map of CO concentrations (mg/m<sup>3</sup>) in a section located near the tunnel centre line

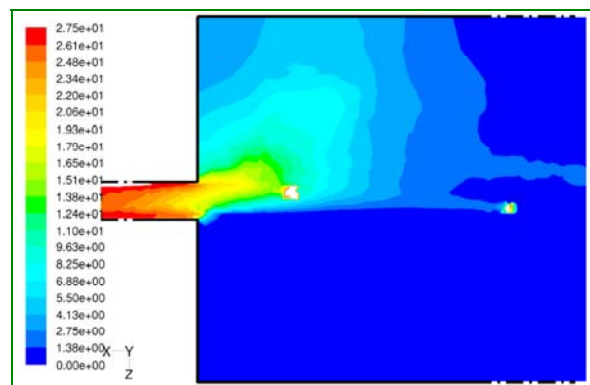

Figure 27 Map of CO concentrations (mg/m<sup>3</sup>) in transversal plane (height of 1.5 m) at tunnel outlet

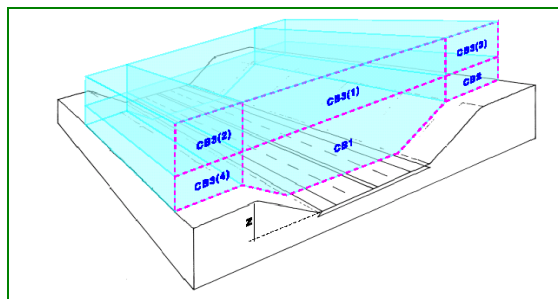

Figure 28 Control Volume – Case of cutting

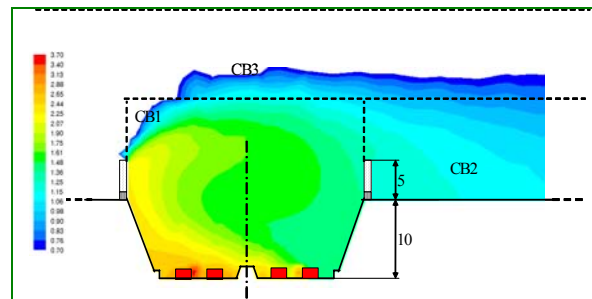

Figure 29 Map of CO concentrations (mg/m<sup>3</sup>) in a section located near the tunnel centre line

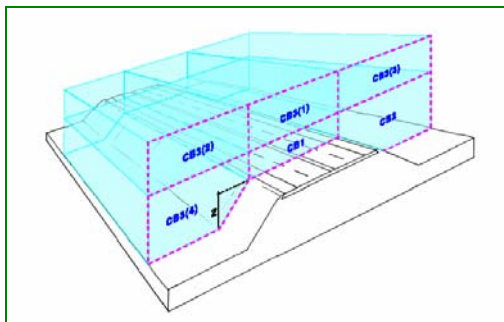

Figure 30 Control Volume – Case of embankment

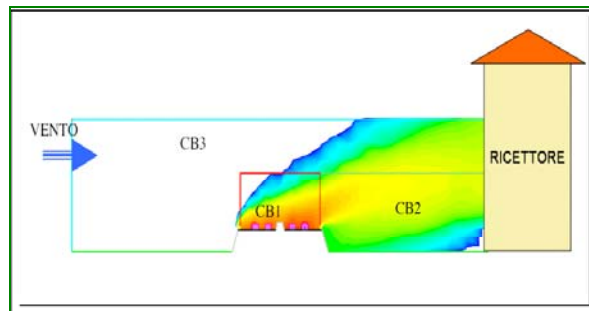

Figure 31 Map of CO concentrations (mg/m<sup>3</sup>) in the longitudinal symmetry plane

As already point out, air pollution is the result of the use of the infrastructure service, frequently registering an imbalance in terms of demand/supply and hence is factor in the generation of pollution in the form of congestion, and does not derive directly from road assets per se. In order to experiment the improvement the air conditioning in tunnel and at the exit an auxiliary subsystem for the air-cleaning active solution was developed. Firstly were defined by models the performance and design parameters and executed laboratory tests on mock-up to select process components. The solution feasibility were verified trough characterisation under simulated traffic conditions on a prototype at full scale. The technical and economical feasibility for a possible use on a real traffic condition site showing the constraints regarding maintenance and energy savings, necessitates a reappraisal of the project in terms of sourcing requirement before its implementation can be achieved.

Autostrade were experimenting the use of TiO<sub>2</sub>, a composite able to dirty avoid and to reduce some air pollutants, when incorporated in paints or mortar. Trial were carried out at Citerna tunnel, in the

Apennine section of the A1, where half of the northern tunnel vault was painted with TiO<sub>2</sub> paint, whilst the second half was left unpainted. Were installed of ultraviolet, or so-called “black” lights, so as to activate the photocatalytic process. The site were monitored in order to verify over time the performances.

### 10.1.9 GENOA PILOT CASE STUDY

The Genoa pilot case study is a plan coordinated by a working group, made up of Autostrade together with institutional offices like the Municipality of Genoa, the Prefecture of Genoa, the municipal environment office and the Autostrade Regional Department, involved in the acoustic protection of the city. It is a full-scale laboratory where different acoustic solutions and procedures are under experimentation. 8 operation/project have been completed in agreement with deadline agreed together with municipalities in 2007, considering that the entire program forecast 16 operations/projects to be carried out on the road noise sources to passively protect 133.000 involved inhabitants by the development of 434.209 m<sup>2</sup> of porous asphalt pavement (carrying out the sound absorption of the frequencies related with tyre-road noise) , 186.000 m<sup>2</sup> of noise barriers (carrying out the sound attenuation in the “acoustic shadow zone” according to source/receptor positions absolute and relative and to screen height/length) and acoustic tunnels (carrying out the sound attenuation values improvements respect to the barriers by means of special shape and various materials, partial or total covers by means of baffles), 154 m<sup>2</sup> noise protection windows & fan-coil system (to comply the legislation immission limits inside the receptor). The main remedial measures of the acoustic control/abatement solution designed & implemented for the city of Genoa, refer to the implementation of innovative solutions whose development and assessment took place in the framework of the NR2C project.

Genoa constitutes an important benchmark because it is characterised by a complex ground morphology (presence viaducts, viaducts, tunnels inputs/outputs), a close integration between residential and industrial buildings with high density of housing buildings, of various heights and conformation, presence of different sources of noise and, precisely separated carriageway motorways, town’s streets, railroad and urban fast highways and by high rates of noise pollution.

The global activities for Genoa pilot case study, including those defined as “public information” were also preparatory to set up the “acoustic remedial action plans” accordingly with the END (2002/49). Moreover, the measures proposed, with the involvement of the local authorities, permitting to exploit operating experiences to verify the scope and outcomes of action plans together with the prevention and remediation work costs verification. The noise countermeasures were carried out with the objective to comply the sound pressure values measured or computed at receptor into defined immission legislation limits.

The methodology provides a three-dimensional acoustic map to identify critical receptors, the prioritisation of measures and the acoustic sizing of the work, performed on the basis of predictive models used also to asses the performances of low noise pavements and anti-noise barriers integration. The simulation model adopted permits the evaluation of the insertion loss obtained with the countermeasure hypotised forecasting the equivalent day/night level obtained after the installation of the remedial measure. The use of material characteristics together with the EN standard permits to define the noise reduction devices minimal performance requirements in terms of sound insulation/reflection and absorption.

Some NR2C solutions were implemented and assessed in the following 3 projects forecasted in the Genoa pilot case study plan (which have identified 29 critical zones and 16 priority measures):

- Marassi (on A 12 Genoa-Roma at km 7+976.50-7+705.50 in suburban contest) completed,
- Villini Negrone (on A10 Genoa– Ventimiglia at km 8+700-10+000 in urban contest) completed,
- Sampierdarena (on A7 Genoa-Serravalle at km 132+200-133+400 in suburban contest),  
undergoing.

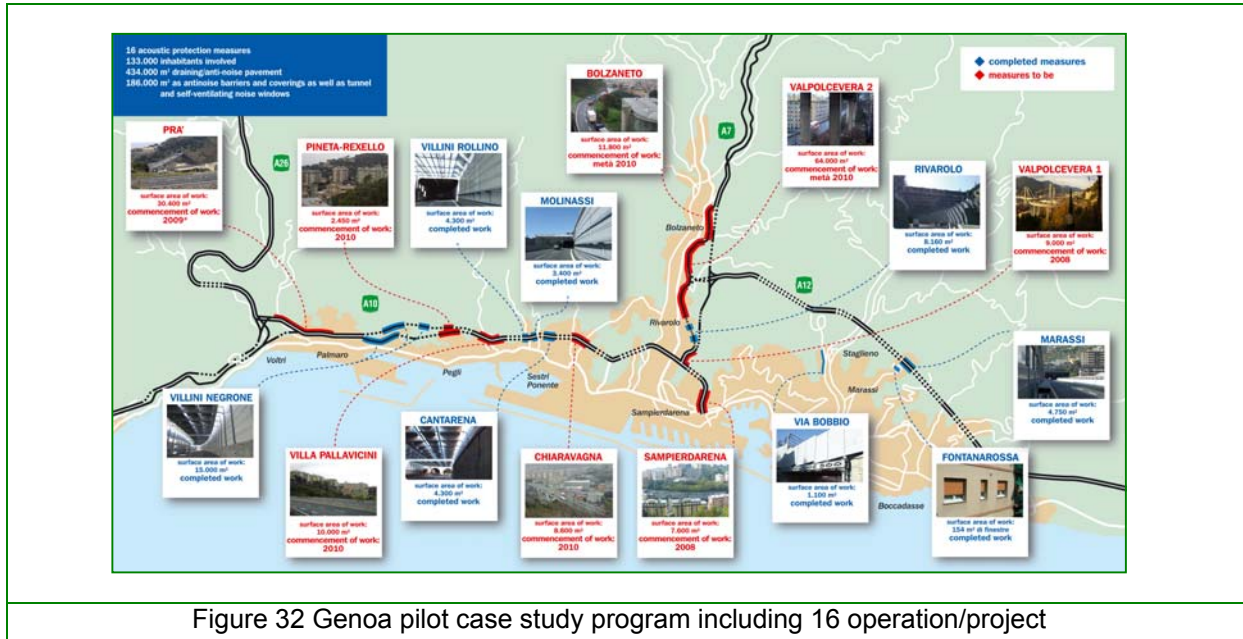

Marassi zone, is characterized by very high buildings (from 8 to 12 floors), each facing one another at about 25 meters from the motorway or very close to entry and exit of Monte Quezzi tunnel. The acoustical pollution at these receivers was complex, that it was originally decided to “stretch” the tunnel; this solution was subsequently shelved for safety reasons and a baffles solution was adopted in its place including bi-absorptive vertical panels, placed at an interval varying from 500 to 900 mm. This design was not sufficient to guarantee sufficient acoustical protection to all the receivers, because the acoustical field close to the tunnel was “a diffuse field”, leading therefore to a poor baffle efficiency in fact they act well when there is an “almost free field” between the source and the receivers. Therefore a special mixed solution was studied and then built through a semi-cover (sound insulating and sound absorbing/reflecting panels) with a central open space fitted with baffles acting as a “silencer” distance reduced to 500 mm.

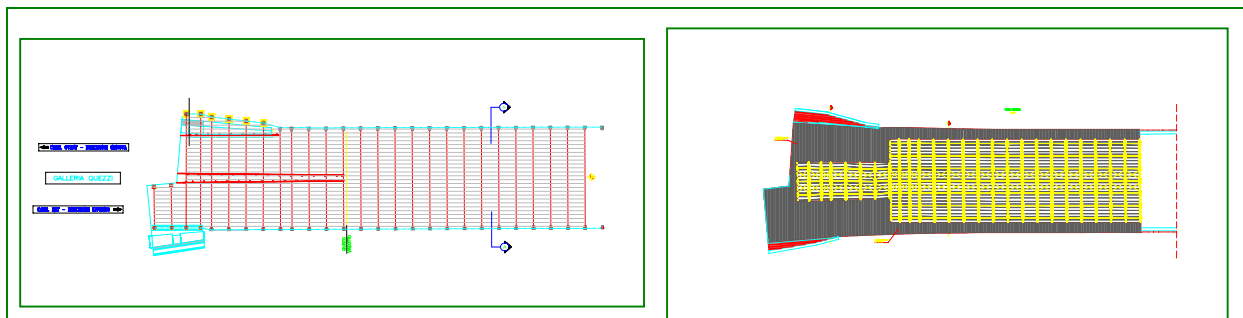

Figure 33 and fig. 34 Genoa pilot case study- Marassi zone project: antinoise tunnel cover design solutions

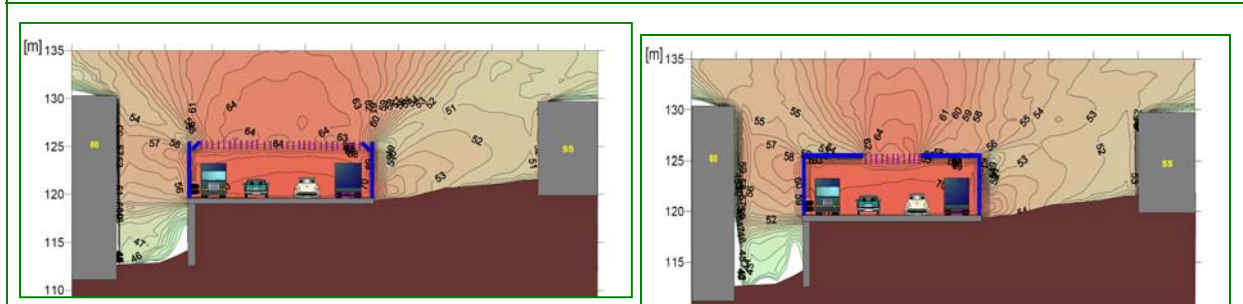

Figure 35 and fig. 36 Acoustical modeling for antinoise tunnel cover at Marassi zone project



Figure 37 and fig. 38 Genoa pilot case study - Marassi zone project post operam

The Villini Negrone zone remedial measures represents a good example of how an area strongly and adversely affected by acoustic pollution, given the close proximity of the buildings to the motorway (the 430 buildings in question were, on average, only 91 metres from the roadside) can be significantly improved thanks to the acoustic abatement infrastructures introduced: this situation represents what is commonly referred to as an acoustical U section.

In Sampierdarena zone were carried out interesting acoustical remedial at Genova West toll station and between the Belvedere and Promontorio tunnels. As the noise protections are placed close to toll station, special attention was paid to evaluate the spectral content of traffic noise, as the area is characterized by very strong conditions of stop and go, and to the road gradient (+- 5%). Therefore at the design stage the sound-absorbing properties of materials have been “tuned” to the most important frequency noise components. On account of the height of the buildings along the A7 motorway and, in some sections, the lowering of the roadbed, the only type of acoustic abatement possible in this zone was the anti-noise tunnel. As regards, in particular, the acoustical remedial downstream of the Genoa Ovest toll station, which is regarded as the continuation of an existing remedial, not only will some modifications to the existing structures be carried out-such as the replacement of the existing baffles with closed sky coverings, whose central part will be transparent - but a new tunnel for an overall length of 295 m will also be constructed.

The remedial project regarding this section has been carrying out by an approach calibrated on the installation phases taking into account that the assembly of the only central truss significantly reducing the closure total time due to the flexibility of trusses side, prepared to receive concrete trusses of variable length which have been permitted by the production trusses standardised for length classes obtaining a total times reduction. Instead the measure to join the Belvedere and Promontorio tunnels will have an overall length of 27 m and be characterised by open sky coverings and baffle tunnels. The acoustic remedial works in order to limit traffic inconveniences, is performed at night. in presence of medium-high traffic flow conditions.





Figure 39 and fig. 40 Genoa pilot case study - Sampierdarena zone project: Genova West toll station

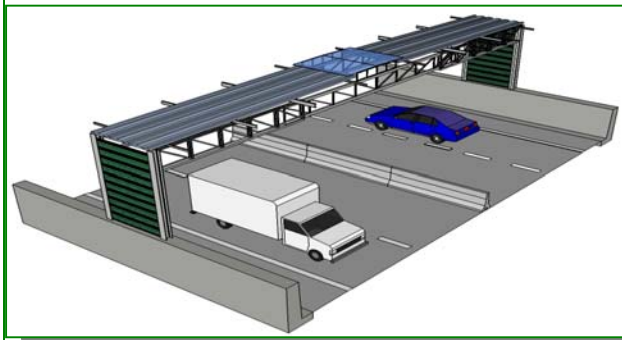
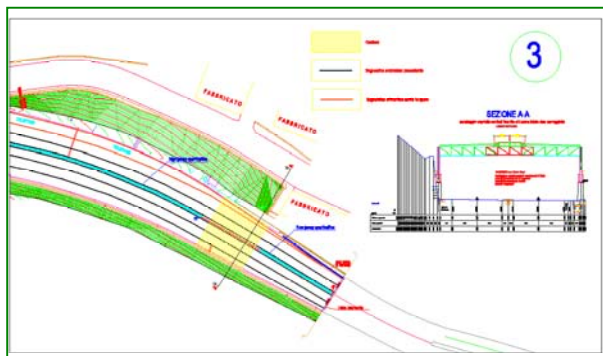
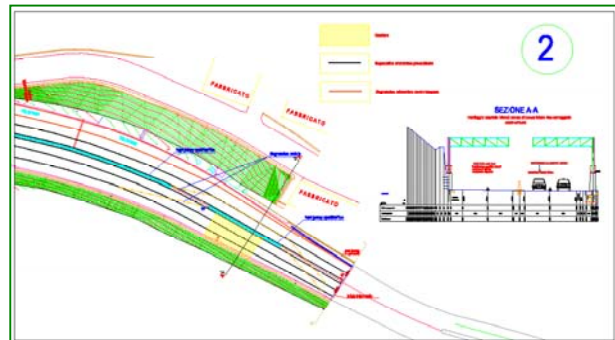
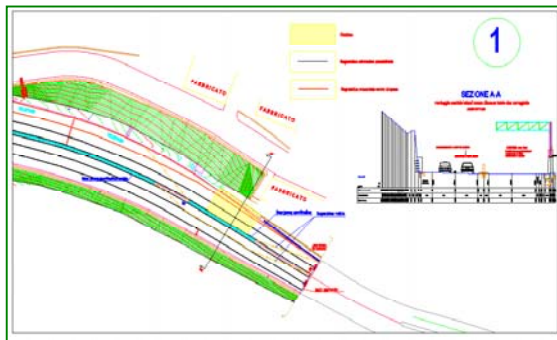

Figure 41, 42, 43 and 44 Genoa pilot case study - Genova West toll station design calibrated on installation

### 10.1.10 CONCLUSIONS

The road environment impacts (due in the existing infrastructure to the traffic and in the new constructions to the works) are in general mitigated following national law obligations & local existing regulations requirements. Innovative solutions to control/abate road noise pollution were developed, implemented and tested within motorway in urban and suburban traffic conditions to specialise innovative noise mitigating road infrastructures performing different functions in different road morphologies.

## 10.2 Air purification by pavement blocks: NO<sub>x</sub> reduction by pavement blocks

Ann BEELDENS (BRRC – Belgium)

### Abstract

The use of materials can influence to a large extent the environmental impact of traffic and of road infrastructure. Especially at urban areas, where the risk on smog formation during hot summer days is high, the use of photocatalytic pavement blocks can reduce the air pollution significantly.

### 10.2.1 GENERAL ASPECTS

Emission from the transport sector has a particular importance on the overall air quality because of their rapid rate of growth: goods transport by road in Europe has increased by 54 % since 1980, while in the past 10 years passenger transport by road in the EU has gone up by 46 % and passenger transport by air by 67 %. The main emissions caused by motor traffic are nitrogen oxides (NO<sub>x</sub>), hydrocarbons (HC) and carbon monoxide (CO), accounting for 58 %, 50 % and 75 % respectively of all such emissions.

These pollutants have an increasing impact on the urban air quality. In addition, photochemical reactions resulting from the action of sunlight on NO<sub>2</sub> and VOC's lead to the formation of 'photochemical smog' and ozone, a secondary long-range pollutant, which impacts in rural areas often far from the original emission site. Acid rain is another long-range pollutant influenced by vehicle NO<sub>x</sub> emissions and resulting from the transport of NO<sub>x</sub>, oxidation in the air into NO<sub>3</sub><sup>-</sup> and finally precipitation of nitrogen acid with harmful consequences for building materials (corrosion of the surface) and vegetation.

The European directives impose a limit to NO<sub>2</sub> concentration of max. 40 µg/m<sup>3</sup> NO<sub>2</sub> (33 ppbV) averaged over 1 year and 200 µg/m<sup>3</sup> (163 ppbV) averaged over 1 hour. These limits gradually decrease from 50 and 250 in 2005 to the final limit in 2010 [3].

Heterogeneous photocatalysis is a promising method for NO<sub>x</sub> abatement. As will be indicated in the last paragraph of this paper, different applications exist. Up till now, UV-light was necessary to activate the photocatalyst. However, recent research indicates a shift towards the visible light. This means that applications in tunnels and inside become more realistic. Especially the application in tunnels is worth looking at due to the concentration of air pollutants at these sites. Up till now, some applications of TiO<sub>2</sub> at the mouths of the tunnels are known, like the application of TiO<sub>2</sub> at the exits of the Göta tunnel in Göteborg, Sweden.

### 10.2.2 HETEROGENEOUS PHOTOCATALYSIS, A PROCESS FOR AIR PURIFICATION

A solution for the air pollution by traffic can be found in the treatment of the pollutants as close to the source as possible. Therefore, photocatalytic materials can be added to the surface of pavement and building materials. In combination with light, the pollutants are oxidized, due to the presence of the photocatalyst and precipitated on the surface of the material. Consequently, they are removed from the surface by the rain. In the deliverable D1.1 – section 4.3 the principle of photocatalytic materials is explained.

In the case of concrete pavement blocks, the anatase is placed in the wearing layer of the tile which is approximately 8 mm thick. The fact that the TiO<sub>2</sub> is present over the whole thickness of this layer means that even if some abrasion takes place by the traffic, new TiO<sub>2</sub> will be present at the surface to maintain the photocatalytic activity. The application of the TiO<sub>2</sub> in combination with cement leads to a transformation of the NO<sub>x</sub> into NO<sub>3</sub><sup>-</sup>, which is adsorbed at the surface due to the alkalinity of the concrete. It is consequently washed away by rain.

### 10.2.3 LABORATORY RESULTS: PARAMETER EVALUATION

Different test methods are developed to determine the efficiency of photocatalytic material towards air purification. A distinction can be made by the type of air flow. With the flow-through method (JIS TR Z 0018 / ISO TC 206/SC N), the air, with a concentration of 1 ppmV, passes over the sample, which is illuminated by a lamp with light intensity equal to 10 W/m<sup>2</sup> in the range between 300 and 460 nm. The NO<sub>x</sub> concentration is measured at the outlet. This test is used for this research. In the 'static'-method, the air is put into circulation into a closed circuit. The abatement of NO<sub>x</sub> is measured over time. This method simulates the 'canyon effect' which can take place in smaller streets in urban areas.

The preparation of the samples is of great importance. Due to the photocatalytic activity, NO<sub>3</sub><sup>-</sup> is deposit on the surface of the material and covers to a certain extend the TiO<sub>2</sub> from the light and from the pollutants. By this the efficiency is lowered over time. By rinsing the surface, the initial efficiency can be reached again. The pre-treatment of the samples in the laboratory is important to obtain reproducible results. This effect is visible in figure 1, where a typical test scheme is applied to the sample: 0,5 hour at 1ppmV NO-concentration, no light – 5 h exposure to an air flow with 1 ppmV NO-concentration and illumination – 0,5 hour with illumination and no exposure. A small increase in time of the NO<sub>x</sub> concentration is visible due to the deposit of the NO<sub>3</sub><sup>-</sup> at the surface.

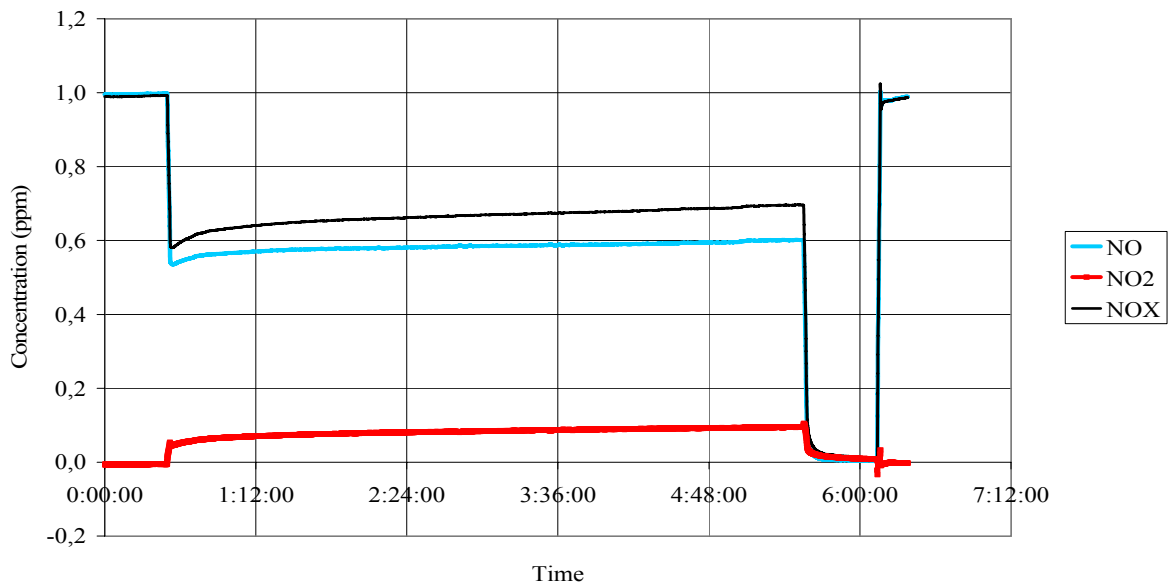

Figure 1 - Results obtained in laboratory according to the standard test procedure.

The laboratory research program consisted of the control of different parameters such as temperature, relative humidity, contact time (surface, flow velocity, height of the air flow over the sample,...). In general it can be stated that the efficiency towards the reduction of NO<sub>x</sub> increases with a longer contact time (larger surface, lower velocity, smaller height of air flow, higher turbulence at the surface) and a lower relative humidity.

Due to the activation of the electron at the surface of the TiO<sub>2</sub>, energy is stored in the material. This energy can be used to form radicals, which react with water or with pollutants. Water is therefore a competitor of the pollutant, by which it may explained that the efficiency is dropping with increasing relative humidity. On the other hand, once the nitrates are present on the surface water is needed to clean the surface again.

Figure 2 shows the influence of the relative humidity on the efficiency, measured on two pavement blocks taken from the pilot project in Antwerp.

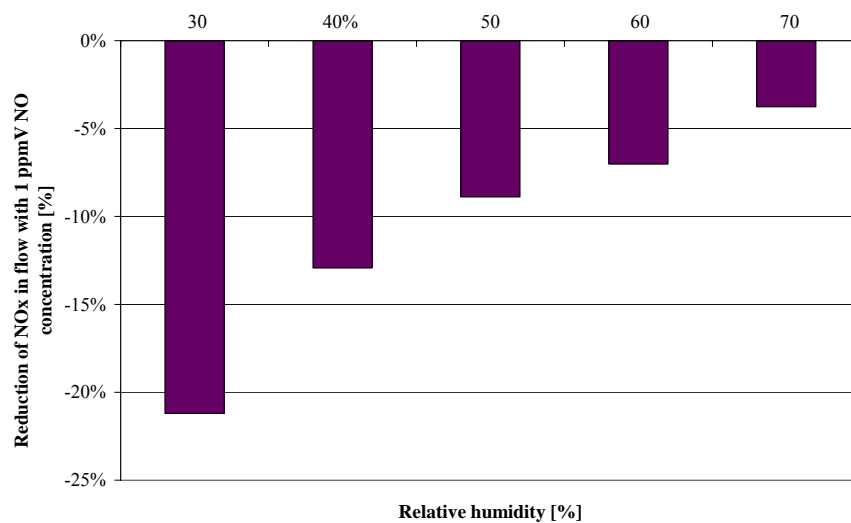

Figure 2 - Influence of the relative humidity on the efficiency

#### 10.2.4 PILOT PROJECT IN ANTWERP

An important issue is the conversion of the results, obtained in the laboratory to real applications. In order to see the influence of the photocatalytic pavement blocks in real conditions, a test section of 10 000 m<sup>2</sup> photocatalytic pavement blocks as pilot project on the parking lanes of a main axe in Antwerp is constructed in 2004-2005. Figure 3 gives a view of the parking lane, where the photocatalytic concrete pavement blocks are applied. Only the wearing layer of the blocks contain TiO<sub>2</sub>. In spite of the fact that the surface applied on the Leien of Antwerp is quite important, one has to notice the relative small width of the photocatalytic parking lain in comparison with the total street: 2\*4,5 m on a total width of 60 m.



Figure 3 - Separate parking lanes at the Leien of Antwerp with photocatalytic pavement blocks.

Two different types of tests were carried out. First of all pavement blocks were taken from the Leien after different periods of exposure. These blocks were measured in the laboratory without washing of the surface and with washing of the surface. The results are presented in figure 4. They indicate a good durability of the efficiency towards NO<sub>x</sub> abatement. The deposition of pollutants on the surface leads to a decrease in efficiency which can be regained after washing.

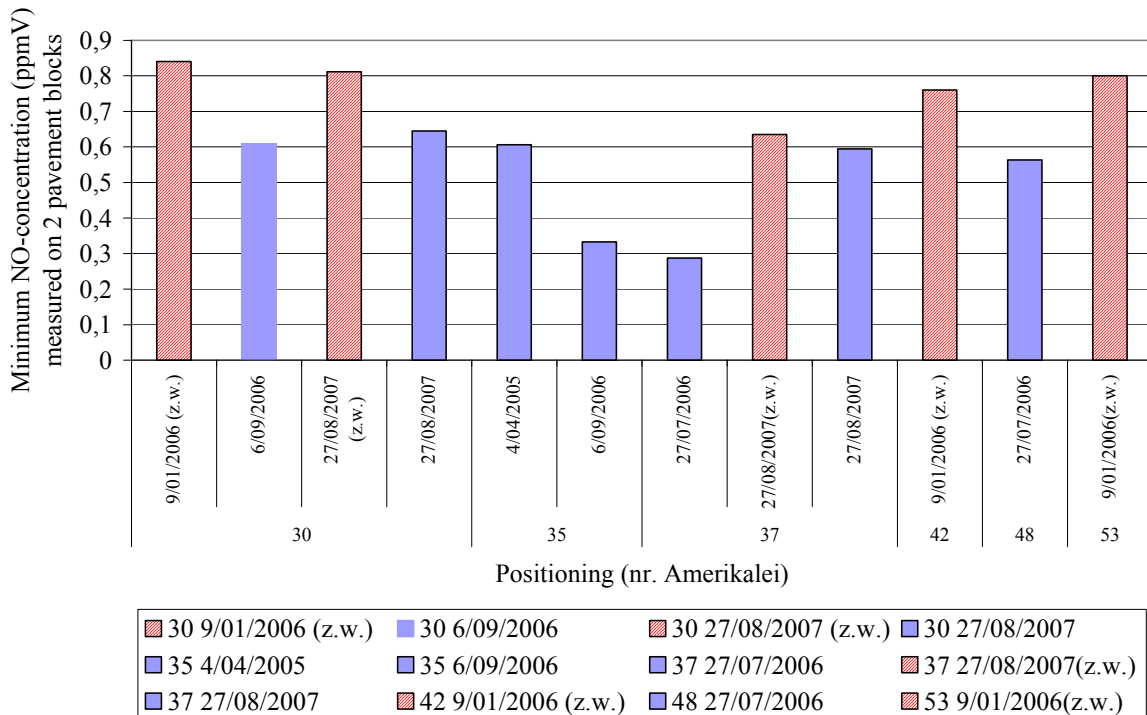

Figure 4 - NO<sub>x</sub> concentration at the outflow, measured on 2 pavement blocks, before (z.w.) and after washing the surface.

Besides the measurements in the laboratory, on site measurements are carried out. Since no reference measurements, without photocatalytic material, exist, the interpretation of these results is very difficult. Especially the influence of traffic, wind speed, light intensity and the relative humidity are playing an important role.

Figure 5 gives an overview of the measurements made on the 9th of June 2006 at 3 different places at the Leien of Antwerp. Consequently, measurements were made at house number 50, 108 and 38 of the Amerikalei. The parking lanes at number 50 and 38 contained photocatalytic pavement blocks, the parking lane at number 108 were placed with classic concrete pavement blocks. The measurements were carried out during 1 day. Parameters of the measurements are shown in table 1.

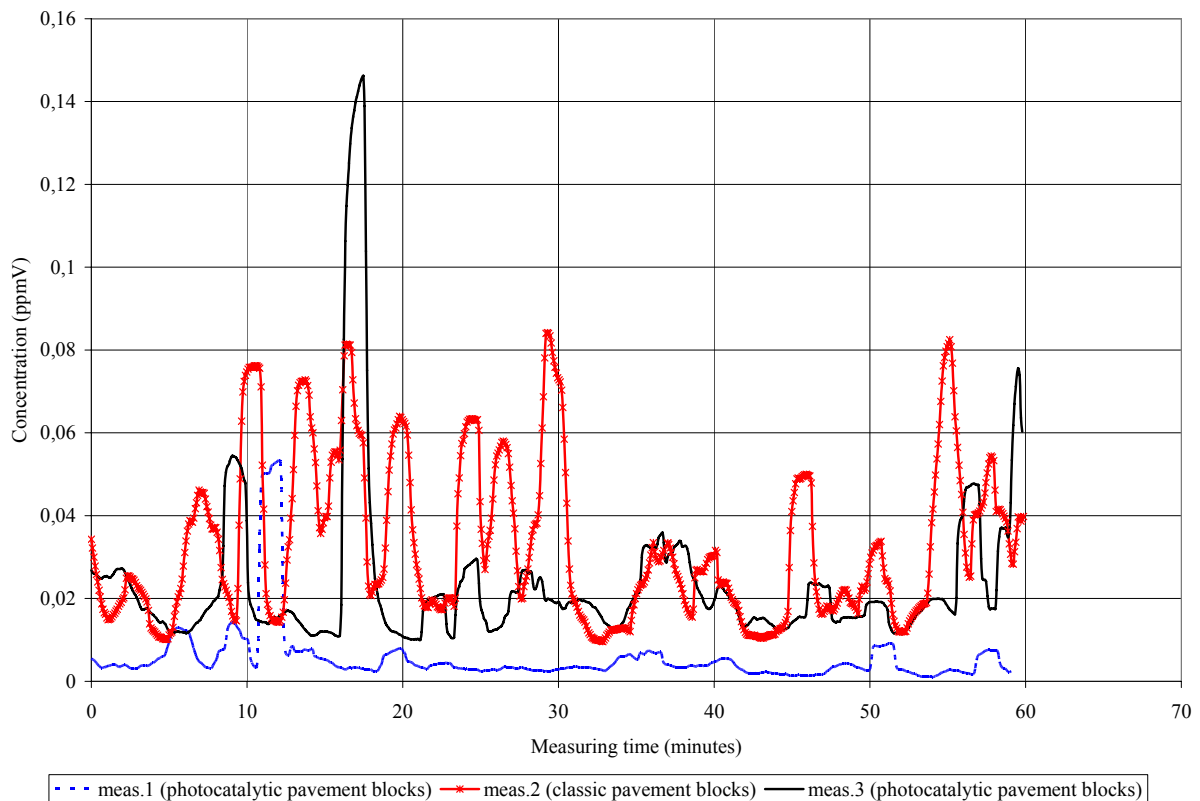

Figure 5 - NOx measurements at the Leien of Antwerp.

Table 1 - Parameters of the measurements at the park lanes of the Leien of Antwerp.

	Time	Vehicles/hour	R.H.	Temperature	Light intensity
1	10:32–11:32	1332	33 %	25°C	12 W/m <sup>2</sup>
2	11:41–12:41	1494	30 %	26,6°C	17 W/m <sup>2</sup>
3	14:10–15:10	1620	25 %	32,4°C	25 W/m <sup>2</sup>

The air was continuously taken at 5 cm above the surface at the side of the photocatalytic pavement blocks. The light intensity was measured parallel to the surface of the pavement blocks. The vehicles were counted manually on the main road of the Leien of Antwerp during the last 10 minutes of the measurement.

The results indicate a decrease in NOx-concentration at the sites with photocatalytic materials. A leveling out of the peaks is visible. The 3rd measurement is slightly higher than the 1st in spite of the lower relative humidity. Although the results presented in figure 4 give an indication of the efficiency of the photocatalytic material, precaution has to be taken since the results are momentary and limited over time.

### 10.2.5 OTHER FIELD TESTS

More and more in situ applications are made in which the relation between the efficiency in laboratory and on site is established. A short overview is given in this paragraph.

One of the first large on site investigation is made in the PICADA project. In May-September 2004, a field experimental campaign is conducted in an artificially constructed street canyon in Guervill, Paris, which had a scale of 1:5. Statistics showing the depollution activity of the rendering versus NOx were extracted from a three month measurement campaign. Important was the development of a numerical simulation tool to demonstrate and assess the depollution effect of the materials [8].

Towards horizontal applications different types may be distinguished: photocatalytic pavement blocks, as is applied in Antwerp, Belgium, in Bergamo, Italy [9] and in Japan; the combination of a hot mix asphalt and a cementitious mortar to which TiO<sub>2</sub> is added [10], applied in Italy and in France or a concrete overlay as is newly applied in Paris, Portes des Vanves, France.

Vertical applications may be found in the Netherlands (as part from the IPL project) [11], in France [12], where photocatalytic materials are applied on noise barriers to achieve noise reduction as well as air purification.

Recent applications are realized in London, UK [13], where a school wall is covered with a TiO<sub>2</sub> coating and extensive measurements are made. New applications can also be found in tunnels, where a combination of TiO<sub>2</sub> and appropriate lighting is applied. In tunnels, due to the concentration of the pollutants, the actual abatement of NO<sub>x</sub> can be much larger.

The translation from the laboratory results to the site efficiency is still a difficult factor. The best results can be achieved by modeling the environment, validating the model by measurements followed by an implementation of the different parameters. In the NR2C-project, the abatement of pollutants, by using photocatalytic materials in tunnels as well as on highways is investigated [14].

### 10.2.6 CONCLUSIONS

The use of photocatalytic materials to minimize the air pollution by traffic is applied more frequently on site in horizontal as well as in vertical applications. Laboratory results indicate a good efficiency towards the abatement of NO<sub>x</sub> in the air by using photocatalytic materials. However, the relative humidity is an important parameter, which may reduce the efficiency on site. If the RH is high, the water will be adsorbed at the surface and prevent the reaction with the pollutants.

Measurements on site indicate a decrease of the peaks due to the presence of the photocatalytic material. Repeated measurements in the laboratory on the photocatalytic concrete pavement blocks confirm the efficiency over time. Although a reduction in efficiency is noticed due to the deposition of the NO<sub>3</sub><sup>-</sup> on the surface, the original efficiency can be regained by washing the surface.

## REFERENCES

1. Beeldens A., 'An environmental friendly solution for air purification and self-cleaning effect: the application of TiO<sub>2</sub> as photocatalyst in concrete', Proceedings of Transport Research Arena Europe – TRA, Göteborg, Sweden, June 2006.
2. Goossens Y., Meneghini GP., European Parliament Fact Sheets – 4.9.6. Air Pollution – (internet) [http://www.europarl.europa.eu/facts/4\\_9\\_6\\_en.htm](http://www.europarl.europa.eu/facts/4_9_6_en.htm), 07/2006.
3. The council of the European Union, 'Council Directive 1999/30/EC (1999) – relating to limit values for sulphur dioxide, nitrogen dioxide and oxides of nitrogen, particulate matter and lead in ambient air', 1999.
4. Fujishima A., Hashimoto K., Watanabe T. (1999); TiO<sub>2</sub>, photocatalysis, fundamentals and applications', BKC, Inc., pp. 176.
5. Murata Y., Tawara H., Obata H., Murata K., 'NO<sub>x</sub>-cleaning paving block', EP-patent 0786283 A1, Mitsubishi Materials Corporation, Japan, 1997.
6. Cassar L., Cucitore R., Pepe C., 'Cement-based paving blocks for photocatalytic paving for the abatement of urban pollutants', EP-patent 1601626, Italcementi S.p.A., Italy, 2005.
7. Cassar L., Beeldens A., Pimpinelli N., Guerrini L., 'Photocatalysis of cementitious materials', Proceedings of the International RILEM symposium on Photocatalysis, Environment and Construction Materials, 8-9 October 2007, Florence, Italy, pp. 131-145.
8. Maggos T., Plassais A., Bartzis J., Vasilakos C., Moussiopoulos N., Bonafous L. (2005), 'Photocatalytic degradation of NO<sub>x</sub> in a pilot street canyon configuration using TiO<sub>2</sub>-mortar panels', 5th International conference on urban air quality in Valencia, Spain, 29-31 March 2005, Picada section.
9. Guerrini G., Peccati E., 'Photocatalytic cementitious roads for depollution', International RILEM symposium on Photocatalysis, Environment and Construction Materials, 8-9 October 2007, Florence, Italy, pp. 179-186.
10. Crispino M., Lambrugo S., 'An experimental characterization of a photocatalytic mortar for road bituminous pavements', International RILEM symposium on Photocatalysis, Environment and Construction Materials, 8-9 October 2007, Florence, Italy, pp. 211-218.
11. <http://www.ipl-airquality.nl/>.
12. [http://www.vinci.com/appli/vnc/vncprs.nsf/980FBF362B56CA43C1256E98003-21E6E/\\$File/eurovia140504us.pdf](http://www.vinci.com/appli/vnc/vncprs.nsf/980FBF362B56CA43C1256E98003-21E6E/$File/eurovia140504us.pdf).
13. Bygott C., Maltby J., Stratton J., McIntyre R., 'Photocatalytic coatings for the construction industry', International RILEM symposium on Photocatalysis, Environment and Construction Materials, 8-9 October 2007, Florence, Italy, pp. 251-266.
14. Luminari M., NR2C final workshop, Brussels, 16th November 2007.

### **10.3 Improving the mechanical properties of a low noise section - SOFTBLOC – Silent poroelastic overlay fixed on tailored cement block pavement**

B. KALMAN (VTI - Sweden)  
D. KOKOT (ZAG - Slovenia)

#### **10.3.1 JUSTIFICATION AND BACKGROUND TO THE INNOVATION**

The innovation consists of a poroelastic material fixed on paving blocks. A poroelastic road material, in the forms we currently know, consists of an aggregate of rubber granules or fibres, sometimes supplemented by sand, stones or other friction-enhancing additives. The rubber can be either from scrap tyres or "new" rubber. It further consists of a binder to hold the mix together. Currently, the binder which was tried is polyurethane, with a binder contents tried so far ranging between 5 and 17 % by weight. In combination with paving blocks this surface combines the excellent noise reducing qualities of the poroelastic material with the possibility to manufacture a large part of the road off site and thus avoiding problems with poor adhesion, which was a major obstacle in previous field tests with poroelastic road materials.

Previous experiences with poroelastic road material were summarized in a report, SILVIA Project Report SILVIA-VTI-005-02-WP4-141005. The report can be downloaded from the website: <http://www.trl.co.uk/silvia/>. To summarize: Early on it was proven that it is not too difficult to produce a poroelastic surface with excellent internal durability. Later test has also confirmed these results and have also demonstrated that the durability towards for example studded tyres is much better for poroelastic road surface (PERS) than conventional pavement materials. On the contrary, the problems encountered in some of the early trials with poor adhesion between PERS and the base layer were also the cause of failure in some later field trials. Laboratory trials on adhesion and some of the later field trials have shown that the adhesion could be made sufficiently strong, if enough binder is applied to the surface and proper attention is taken to cleaning of the base layer prior to adding the binder. The risk of having poor adhesion could probably be completely avoided if the binding is done in a controlled environment. Wet friction was and still is a major obstacle for poroelastic road material. The initial wet friction of the recently produced PERS was more than sufficient. However, the excellent wear resistance of rubber has the adverse effect, that the friction enhancing materials added to the mixes were worn away faster from the surface than the rubber.

#### **10.3.2 IDENTIFICATION OF KEY POINTS TO IMPROVE**

In many of the previous experiments the lack of adhesion between poroelastic and underlying layers was the reason for failures. This is also the reason for choosing a pavement structure where poroelastic layer is layed on concrete (paving) blocks. In this way the critical gluing can be made in more controlled and proper manner and environment.

Taking into account problems and reasons for failure of test fields in Japan, we have identified and selected some key point topics for improvement. The foundation for the blocks (bedding layer) has to be improved, intending to avoid the Japanese failure.

The previous experiments are showing that a friction characteristic of the poroelastic surface still needs to be improved. It is expected that this can be done by adding new friction-enhancing additives to the poroelastic mixture. The friction enhancing material that will be tested will be very hard and wear resistant material. The influence of the hardness of the poroelastic material on the friction properties will also be tested. Recently there have been indications that comparatively hard poroelastic material has better durability of the wet frictional properties compared to soft versions of the material.

The research in this innovation was focused on solving two major problems with this type of surface:

- the wet skid resistance must be maintained at an acceptable level for a reasonable operating time for a typical road condition
- the stability of the system of blocks and stabilizing (bedding) layer must be sufficient for a reasonable operating time and for a mix of light and heavy vehicles.

### 10.3.3 WET SKID RESISTANCE

A laboratory test scheme was set up to study means for having an interlocking block surface covered with a poroelastic material that (together with the blocks) is both resistant to rutting and has a durable wet friction. For improving the frictional properties, a test will be conducted to study the influence on the durability of friction of binder hardness, addition of silicon carbide to the mix and pre-treatment of the rubber crumb.

For simulation of the polishing effect of rolling tyres on a road surface, the VTI pavement testing machine will be used. The pavement testing machine is a circular track with a diameter of approximately 5 metres. Four or six wheels are rolling on this surface at a speed up to 70 km/h (see Fig. C.5.1). The power to the traction of the wheels is delivered by electrical engines attached on each of the wheel axles. The load on each wheel is adjustable but is usually fixed at 450 kg. The wheels do not follow a circular track; rather there is a lateral movement of the wheels to simulate a realistic distribution of wheel paths. The test can be made in dry or wet conditions. When wet conditions are used, fresh water is constantly sprinkled over the surface. The evolution of the friction will be tested with the British Pendulum method and by manually pushed equipment developed at VTI which measures the friction on a partially slipping wheel pushed at a speed of approximately 5 km/h.



Figure C.5.1: The Pavement Testing Machine at VTI.

### 10.3.4 RAW MATERIAL

#### Rubber granules

The maximum density of the rubber granules was determined with the method EN 12697-5. The density was 1.141 g/cm<sup>3</sup>.

Since the grading curve of the rubber granules proved to be very narrow a combination of a large number sieves with nominal sizes around 1-5 mm was used. The grading curve of the rubber granules is presented in figure C.5.2. The sizes of the granules ranged from 1.4 mm to 4.0 mm.

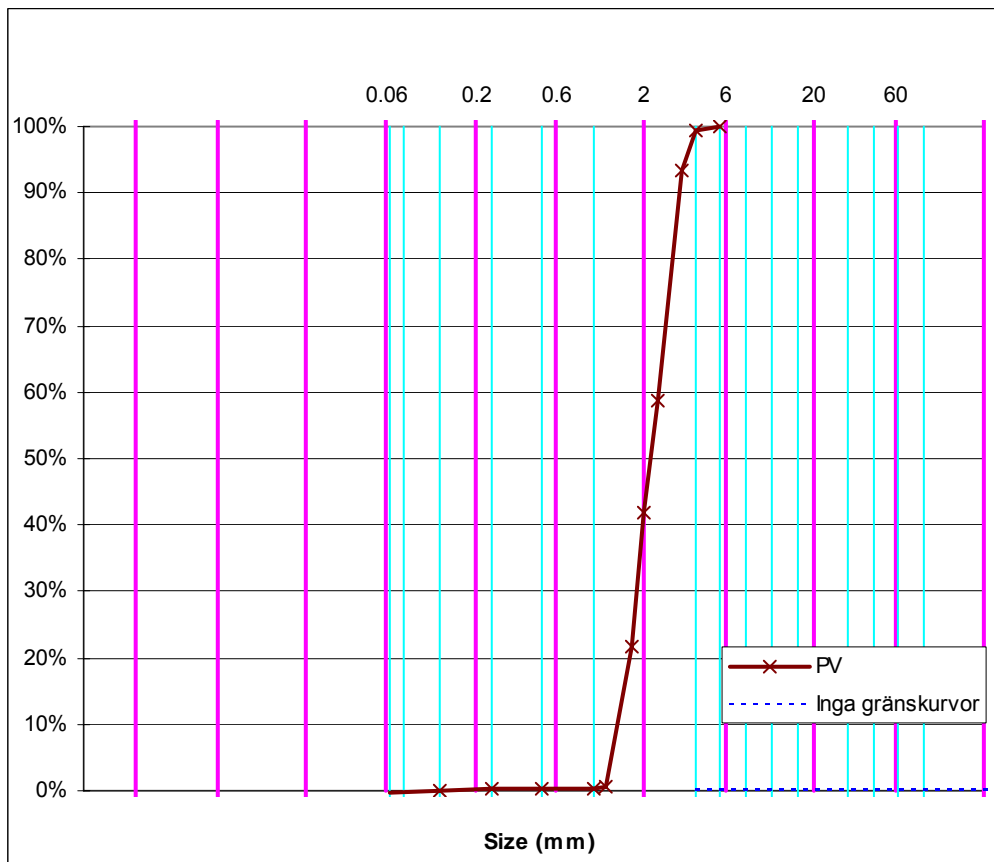

Figure C.5.2: Grading curve of the rubber granules (PV).

### Hardened rubber granules

The hardness of tire rubber is usually about 50-60 Shore A. The hardness of the rubber could to some extent be adjusted to higher values if the rubber is artificially aged. In order to check the influence of rubber hardness towards the durability to friction, a part of the rubber granules were artificially aged in a forcefully ventilated oven at 90°C for 12 hours. The granules were kept in 5 L buckets without lids. The granules were noticeable harder but the hardness could not be checked with a shore meter as the granules are too small to make any measurement with a conventional Shore meter meaningful.

### Polyurethane

Two types of polyurethane binders were tested.

The first one, Flexilon 1109, is a prepolymerized MDI polyurethane produced by Rosehill Ltd. UK. The density of this binder is 1.10g/cm<sup>3</sup> and the hardness of the cured product matches the hardness of rubber, e.g. approximately 60 Shore A. This binder is referred to as the soft binder in this report.

The other product tested, was specially produced for our tests. The Swedish representative for Lagomat/Elastogran/BASF. The product was a two component polyurethane binder with a design hardness of the cured product of approximately 90 Shore A. This specially formulated product didn't have any name and is referred to as the hard binder, in this paper.

### Catalyst

A substituted morpholine compound was used as catalyst to decrease the curing time.

### Friction enhancing material

Silicon carbide, or carborundum, was used to improve the wet friction of the poroelastic material. The material was delivered from Saint Gobain Abrasives. The product used was SIKA ABR IV F150 i.e. the carborundum granules passed a 0.104 mm sieve. The density of the material is 3.22 g/cm<sup>3</sup>.

### 10.3.5 PRODUCTION OF TEST MATERIAL

The production of the test materials were done mixing all compounds in a single mixing pot followed by curing in a mould with a fixed volume. Having precise control of the amount of the mixed material and their densities enabled us to tune the air void content to the design value of 21%. The design value for the air void content was chosen to be rather low to what is possible, but since the purpose of the experiment polishing and the durability of wet friction, a high air void content could give less wear resistance and thus jeopardize the aim of the experiment.

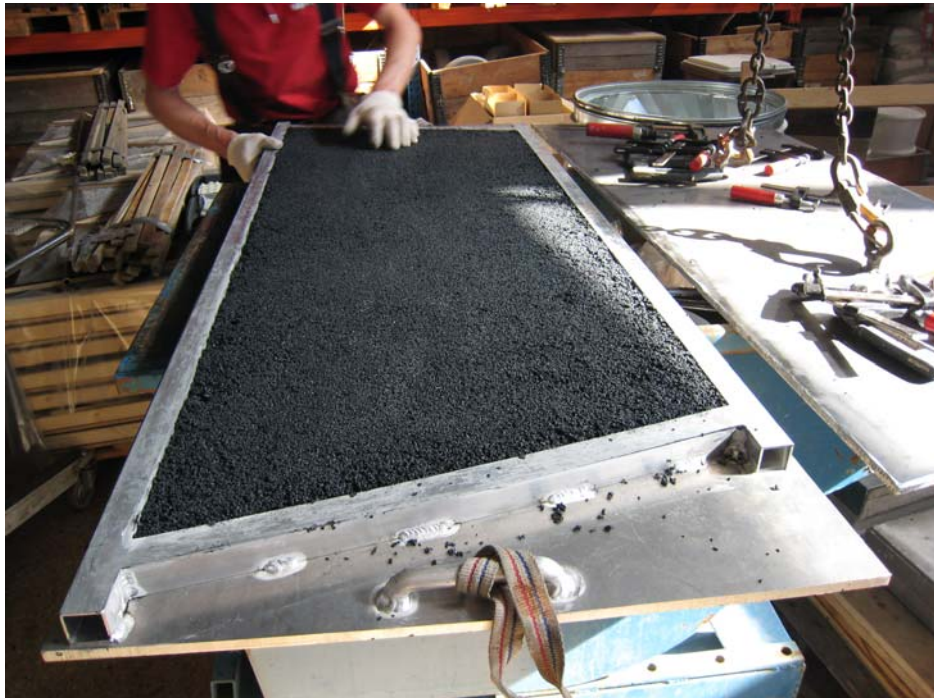

Figure C.5.3: Production of test material.



Figure C.5.4: Production of test material. Releasing the finished material from the mould.



Figure C.5.5: Production of test material. Mounting the material in the PVM.

The following mixes were produced:

Number & Name	Rubber	Binder	Rubber content % (w/w)	Binder content % (w/w)	Silicon carbide content % (w/w)
2 Hard, reference	Un-aged	Hard, two component	79	21	-
4 Hard, abrasive	Un-aged	Hard, two component	65	16	19
5 Hard abrasive and aged	Aged	Hard, two component	65	16	19
6 Soft, abrasive	Un-aged	Soft, one component	65	16	19
1 Rosehill abrasive	Not available	Not available	Not available	Not available	Not available

Two plates, A and B, were produced of each mix type and mounted in the PVM for polishing and wear tests.

### 10.3.6 TEST DESCRIPTION

#### Pavement testing machine PVM

The VTI Pavement testing machine (PVM) is a circular test track with a track diameter of 5.25 m. The machine can be used to do accelerated tests of tire road interactions. The machine has been used for accelerated road wear studies, accelerated traffic polishing studies and studies of emissions of particulate matters from tire road interaction etc. In this study the intention is to focus on traffic polishing, but wear will also be an issue. The wheels in the PVM are driven by electrical engines. Beside the circular movement of the wheels, there are also lateral movements of the wheel, to make the wheel tracks more realistic.

During the test water was sprinkled over the surface with a rate of 6-8 L/minute, see figure C.5.6.



Figure C.5.6: The surfaces were sprinkled with water @ 6-8 L/minute during the accelerated traffic polishing tests.

The air temperature in the test hall was kept at 10-12°C during the tests. The PVM was fitted with four wheels with the dimensions 185/65 R15. The tires were inflated to a pressure of 2.5 bar. Each tire was pushed against the road surface with a load equal to 450 kg. Two types of tires were used. For the first 102 000 revolutions Nokian Nrhi tires was used. These tires are of normal summer type. After the first 102 000 revolutions the tires were shifted to Nokian Hakkapelitta Q tires and the PVM run for another 50 700 revolutions. These tires are used in winter time in the Nordic countries but they are not fitted with studs, rather the grip is accomplished with softer rubber composition in the tread and more sipes in the tread pattern. Such tires are commonly referred to as “friction tires”. The purpose of shifting the tires was to see if the tire type had a decisive role for the traffic polishing effect.

The speed was kept at 60 km/h for the first 23 000 revolutions but was then increased to 70 km/h. Higher speed increase the traffic polishing effect and the wear of the tires per revolution.

### Friction tests

Friction coefficients was measured with a device developed at VTI called the Portable Friction Tester, PFT. The friction was measured on wet surfaces. The PFT is a small device, weighing 38 kg, which is pushed by the operator, see figure C.5.7, and measures the friction coefficient for a wheel at constant slip, i.e. the measuring wheel is rotating at a lower speed relative the road surface than the device traction wheels. The measuring wheel has a slip of 21%, i.e. the measuring wheel is rotating at 21% of the speed of the device traction wheels. The friction coefficient is measured at normal walking speed. In Sweden, the wet friction coefficient should be above 0.5, although the device for measuring the normative friction coefficient is not the same as the PFT, rather a full size car equipped with a fifth measuring wheel. Friction was measured on the poroelastic material in the rolling direction of the PVM.



Figure C.5.7: The Portable Friction Tester used for measuring the wet friction coefficient at walking speed on the poroelastic surfaces. In the figure the PFT is placed with the measuring wheel on a road marking.

### 10.3.7 RESULTS

The accelerated test was performed for in total 152 700 revolutions, i.e. the surfaces was run over by a tire for 610 800 times. The first 23 000 revolutions were done at 60 km/h and the rest at 70 km/h. Initially and at seven intervals the machine was stopped and the friction coefficient was measured in the rolling direction of the wheels, with the PFT. Already at the first stop at 23 000 revolutions both plates of one surface and one plate of another surface was broken down. There were tendencies on some of the other test plates that some of the material wasn't durable enough. At the second stop at 45 000 revolutions there was in total 2 sections that was broken down and one plate of another section that was broken, see figure C.5.8 for an example of a broken test plate. From there and onwards the remaining plates were intact except for some wearing. All broken plates had to be replaced with dummy plates not to prevent the wheels to jump up and down when they passed the broken part of the track. At the end of the experiment the rut depth was measured with a straight edge.

The rut depths are presented in table C.5.1.

Number & Name	Rut depth plate A (mm)	Rut depth plate B (mm)
2 Hard, reference	broken	broken
4 Hard, abrasive	broken	broken
5 Hard abrasive and aged	broken	4.1
6 Soft, abrasive	0.5	1.2
1 Rosehill abrasive	2.3	1.1

Table C.5.1 Rut depth at the end of the accelerated testing in the PVM.



Figure C.5.8 Broken plate at after 23 000 revolutions in the PVM.

The friction coefficients are presented in table C.5.2.

Revolutions		0	23000	45000	65000	102000	120000	152700	175650
Plate number									
2	A	0.65							
	B	0.58							
4	A	0.55	0.58						
	B	0.56							
5	A	0.97	0.73	0.97	0.73	0.97	0.73	0.97	0.73
	B	0.55	0.67	0.69	0.69	0.72	0.82	0.83	0.87
6	A	1.14	1.05	1.08	1.00	0.95	1.00	0.92	0.95
	B	1.04	1.00	1.06	1.03	0.95	1.03	0.99	1.05
1	A	0.72	0.95	0.96	0.91	0.88	0.92	0.94	0.94
	B	0.87	1.03	1.04	1.03	0.97	0.99	1.00	1.00

Table C.5.2: Evolution of wet friction coefficient in the accelerated polishing test. At 102 000 revolutions the tires were shifted from regular summer tires to friction tires.

The friction coefficients presented in table C.5.2 for the material with silicon carbide additions are very high. It is also obvious from the table that the silicon carbide addition did give the poroelastic material a lasting wet friction and the polishing action of the tires was weak for silicon carbide.

Some of the material had a very poor wear resistance and that the artificial ageing of the rubber only made poroelastic material perform worse. The best performing materials were the material produced by Rosehill with addition of abrasive material and the material produced with a soft one component binder with silicon carbide as friction enhancing material.

### Stability of block pavement

#### *Pavement structure and materials characteristics*

Four different setups were tested. First, tests were performed on a structure where cement concrete blocks with a glued poroelastic overlay were placed onto a sand bedding layer. The second test setup was the same only that it included watering of the pavement structure. The third and fourth setups were parallel cases, except that the cement concrete blocks were placed onto a cementitious screed bedding layer. The pavement structures were prepared in a special wooden mould.

In total there were four test cycles. One cycle consisted of a piston-induced dynamic loading of the test structure, as can be seen in Figure C.5.9. There were 100,000 vertical loadings applied through a heavy vehicle tire, each time of maximum load of 35 kN. The loading equals 100,000 passes of 140 kN axle load. The vertical displacement of the structure was monitored and followed by three LVDTs, mounted on a framework and placed along the tire.

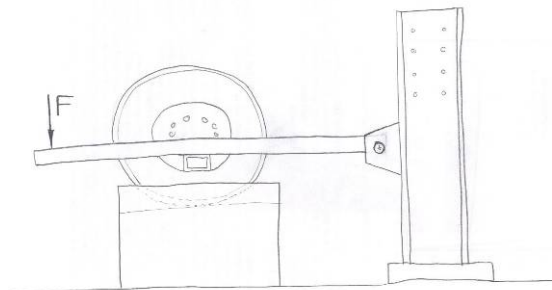

Figure C.5.9: Test assembly with a sketch showing the testing principle

The pavement structure can be seen from Figure C.5.10. Poroelastic material was cut in the shape of the cement concrete blocks and glued to them. Blocks were placed into a bedding layer (sand or cementitious screed, 5 – 6 cm), that was laid onto two asphalt layers (6 + 3 cm). At the bottom of the structure there was laid the unbound material layer (30 cm). When the concrete blocks with poroelastic cover were laid into the bedding layer, dry siliceous sand 0/2 mm was used to fill the spacing between each block and spacing between block assembly and the wooden mould.

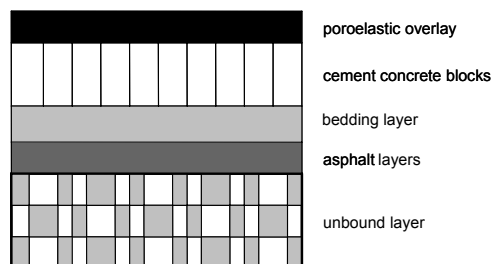

Figure C.5.10: Structure of the tested pavement

### Poroelastic cover on cement concrete blocks

The poroelastic material that was used is named “Tokai” and is in more detail described in the EU-project SILVIA report no. SILVIA-VTI-005-02-WP4-141005 [3]. Originally it was prefabricated in rubber panels 1×1m<sup>2</sup> and imported from Japan. The same material was used for testing at the test site in a residential area in Stockholm. The panel thickness is of 30 mm and it is made of the rubber fibres. A polyurethane type binder was used as a binder for the mix. On the underside the panels have a square mesh (200×200 mm) of drainage channels. From panels there were pieces of the poroelastic material cut in the wavy shape of the standard commercial cement concrete blocks (see Figure C.5.11).

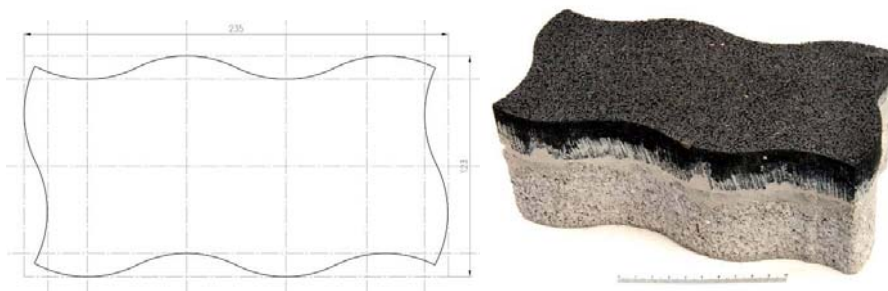

Figure C.5.11: Concrete block with poroelastic cover

The critical gluing was done in a controlled and proper manner and environment – in a laboratory. The poroelastic material was glued to concrete blocks using a mixture of the two epoxy based adhesives. The mechanical properties - tensile strength and shear strength - of the new adhesive were tested before gluing the pieces together. For determining the shear strength, the joint between a piece of poroelastic material and concrete block was loaded in longitudinal direction. For determining the tensile strength, the samples were torn apart using the steel caps that were additionally glued to pieces of poroelastic material.

The test samples were cured for 72 hours in laboratory conditions (23°C, 50 % r.h.). A testing machine ZWICK Z100 was used for loading specimens, with a rate of loading of 10 mm/min. The determined shear and tensile strengths of 12 multiple specimens are shown in Table C.5.3

Specimen	Joint shear strength (MPa)	Break point deformation (mm)	Joint tensile strength (MPa)	Break point deformation (mm)
1	0.45	6.22	0.63	4.53
2	0.53	6.30	0.69	5.47
3	0.47	7.42	0.75	6.60
4	0.40	5.22	0.60	5.57
5	0.43	5.68	0.70	7.04
6	0.46	4.49	0.75	6.27
7	0.61	4.43	0.59	4.27
8	0.49	6.22	0.58	4.32
9	0.43	5.77	0.60	4.98
10	0.59	5.72	0.53	4.56
11	0.62	4.84	0.54	5.20
12	0.61	6.36	0.63	5.00
average	0.51	5.72	0.63	5.32
st. deviation	0.08	0.87	0.07	0.91

Table C.5.3: The results of the shear and tensile strength tests

At both tests and with all the specimens, the weakest point was the poroelastic material. In all cases the breakdown happened in the poroelastic piece, whereas the joints between poroelastic material and concrete block remained in good conditions. The failure was in poroelastic material and not in the adhesive.

### Bedding layer

As a bedding layer there were two options chosen. First option was to lay the concrete blocks in the sand 0/4 mm layer, the second one was to lay them in the cementitious screed layer.

The grading of the sand aggregate that was used for the bedding layer can be seen from Table C.5.4. The moisture content of five samples varied between 6.73 % and 7.72 %.

% passing										
Sieve size (mm)	8	4	2	1	0.71	0.50	0.25	0.125	0.090	0.063
Sand 0/4	100	99	76	45	33	29	18	12	10	9.3

Table C.5.4: Grading of the sand bedding layer

For the cementitious screed bedding layer we have chosen a PflasterDrainmörtel GK 4 (porous mortar) product from Baunit company. The product was prepared and laid into the pavement according to the manufacturer's directions. The moisture content of five samples varied between 4.36 % and 5.95 %.

### Asphalt layers

There were two layers placed into the pavement structure: AC 8 of 3 cm layer over bituminous well graded crushed stone BD 22s layer (asphalt concrete base layer; 6 cm). The characteristics of the binder that was used in different mixes can be seen from Table C.5.5.

Binder type	bitumen B50/70	bitumen B70/100
Layer	Bituminous crushed stone BD 22s	Asphalt concrete BB 8
Ball and ring test (°C)	51.2	46.2
Penetration (mm/10)	53.0	86.0
Index of penetration	-0.8	-0.9

Table C.5.5: Characteristics of binder in the asphalt mixes

Soluble binder content, particle size distribution of mineral aggregates and other measured characteristics of both mixes are detailed in NR2C – Deliverable D22.

### Unbound layer

For the unbound layer the crushed stone aggregate 0/32 mm was used. The grading of mineral aggregate and other characteristics can be seen from tables C.5.6 and C.5.7. The fines content of the aggregate is 4 %.

% passing													
Sieve (mm)	63	45	31.5	22.4	16	11.2	8	4	2	0.71	0.25	0.090	0.063
Sand 0/4	100	94	92	78	65	53	43	29	19	10	6	4	4.0

Table C.5.6: Particle size distribution of the mineral aggregate for unbound layer

<i>Geometrical properties</i>		
Flakiness index	%	17
Shape index	%	18
<i>Fines content</i>		
	%	4
<i>Assessment of fines</i>		
Sand equivalent test	%	45
Methylene blue test	g/kg	1.4
<i>Resistance to fragmentation</i>		
(Los Angeles coef)	%	24
<i>Resistance to wear</i>		
(micro Deval)	%	9
<i>Particle density and water absorption</i>		
$\rho$	Mg/m <sup>3</sup>	2.71
WA <sub>24</sub>	%	0.4

Table C.5.7: Characteristics of the mineral aggregate for unbound layer

### Test setup

In total there were four test cycles. One test cycle consisted of a hydraulic piston-induced dynamic loading of the test structure. In total, 200,000 loading cycles (100,000 cycles without watering and another 100,000 cycles with watering the pavement) were applied to each of two pavement structures. When preparing the second pavement, the same concrete blocks were used. The blocks were rearranged in a way that the blocks on which the load was applied (central blocks) were moved to outer position and vice versa. The frequency of applying the load to the pavement surface was of 0.25 Hz. One loading cycle was performed in about 4 seconds, with minimal loading of 5 kN and maximal loading of 35 kN. The vertical displacement of the structure was monitored and followed by three LVDT sensors, mounted on a framework and placed along the test tire.

In the second and fourth test setup, water was poured into the pavement, to simulate a light rain and two heavy rainfalls. For the first, 8 litres of water per 1 m<sup>2</sup>, were poured into the pavement in 8 hours. The heavy rain equals to 45 litres of water poured into the pavement (1 m<sup>2</sup> area) in 30 minutes.

Water was let to freely run out the pavement (and the wooden mould) and it was captured into containers and utensils. When performing the tests it was supposed that the “real” pavement, made on site, would have good drainage system helping water run off and away of the pavement.

### Results

Figures C.5.12 and C.5.13 show the results for each of the four test setups: the pavement with sand bedding layer (pavement 1), the same pavement into which the water was poured into during the testing, the pavement with screed bedding layer (pavement 2), and again the same pavement that was watered. On each figure there are three lines, representing the result of deflection measurements of each of the three LVDT sensors.

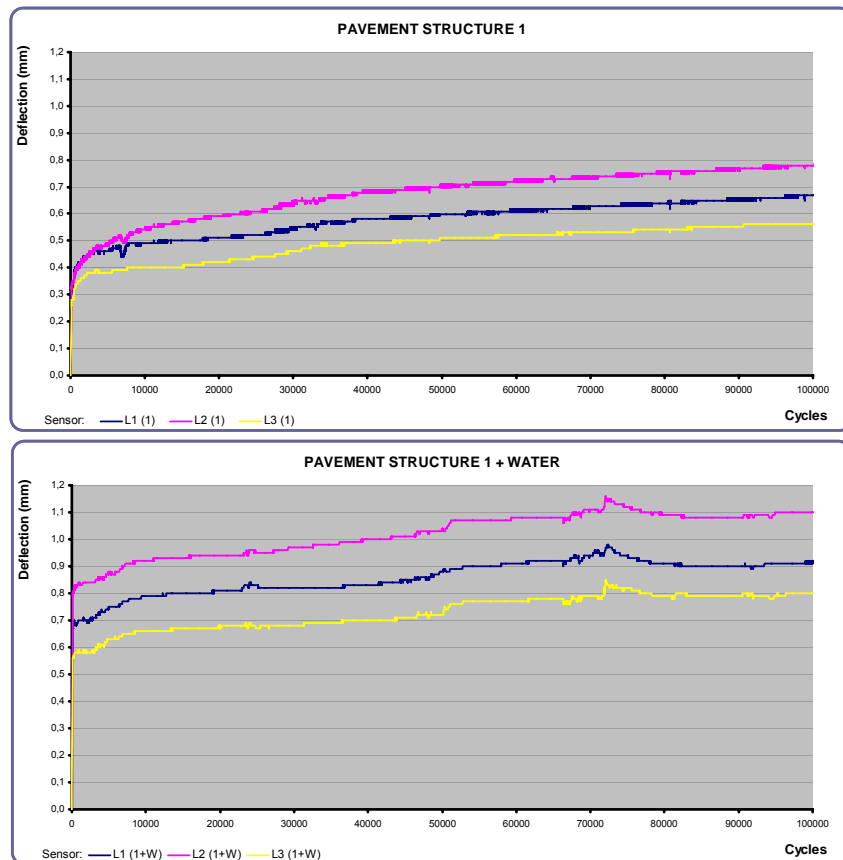

Figure C.5.12: Results for tests on pavement with sand bedding layer

It can be seen that the levels of deflections measured by sensors are considerably closer each other by the pavement with screed bedding layer (porous mortar) than by the sand bedding layer pavement. This is attributed to higher stiffness and compactness of the screed layer, compared to the sand layer. Although the concrete blocks were laid into the sand layer and compacted as much as possible, it seems that the load applied to the pavement was distributed much more uniformly to lower layers through the screed bedding layer than through the sand layer.

When looking at the results for sand bedding layer pavement and comparing the deflections registered by sensor L1 to deflections by sensors L2 and L3, it can be seen that the first sensor values vary between the values of the remaining two. Since these two sensors were located to the opposite ends of the same block, we can assume different local deformations in the sand bedding layer. Deflections of the concrete blocks on screed bedding layer were relatively very uniform.

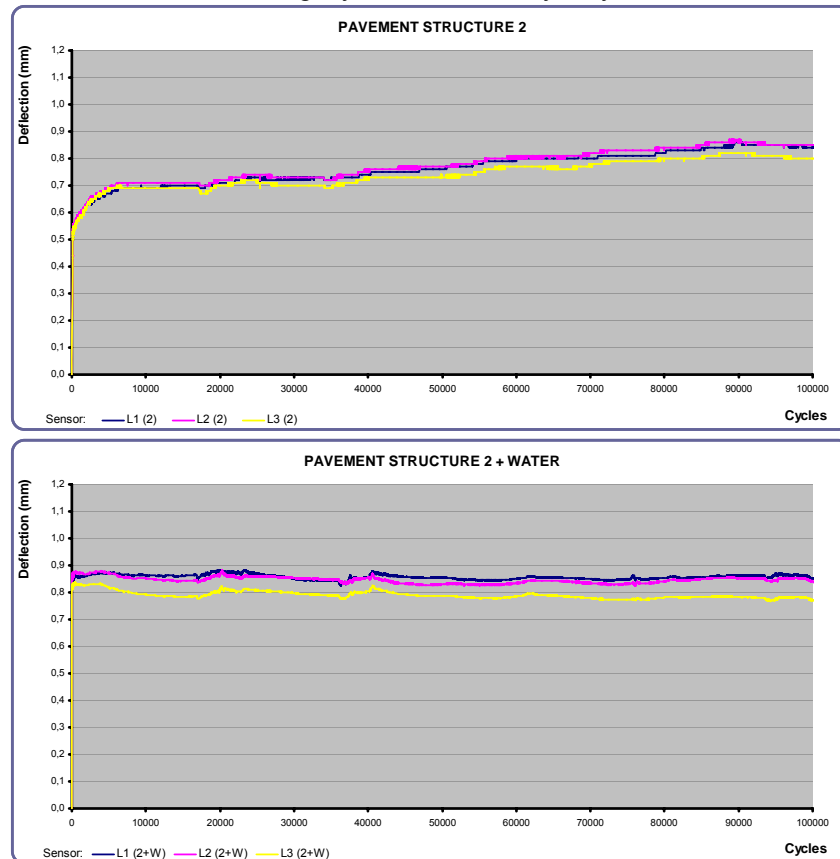

Figure C.5.13: Results for tests on pavement with screed bedding layer  
 Figure C.5.14 shows the test results for each of the three LVDT sensors.

The results from all three sensors show that the pavement with screed bedding layer was deformed under load applied more than the pavement with sand bedding layer for first 100,000 cycles. From that point on, the trend changed radically and deflections of the screed bedding layer pavement stayed almost at the same level throughout next 100,000 loading cycles, like the screed has hardened and the layer was compacted to its maximal state. Contrary, the deflections of sand bedding layer pavement increased for all the loading time ending with the deflections (much) higher than by the other pavement.

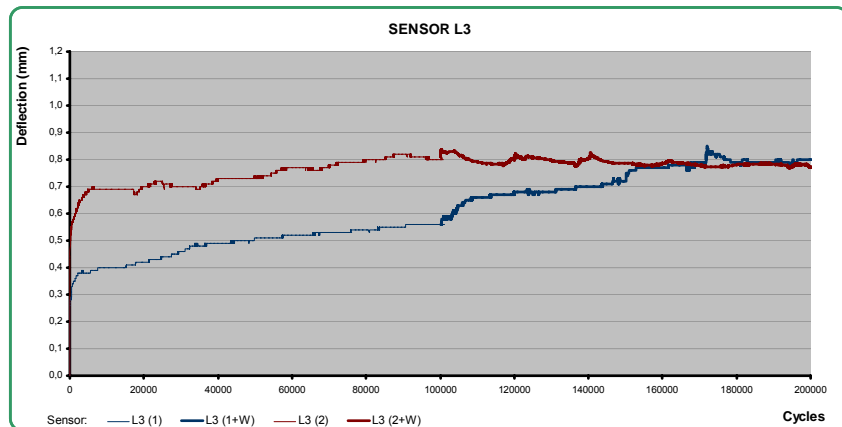
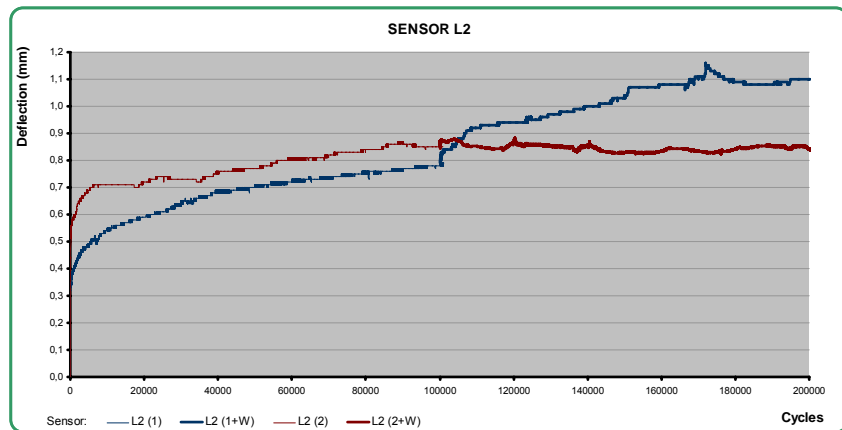
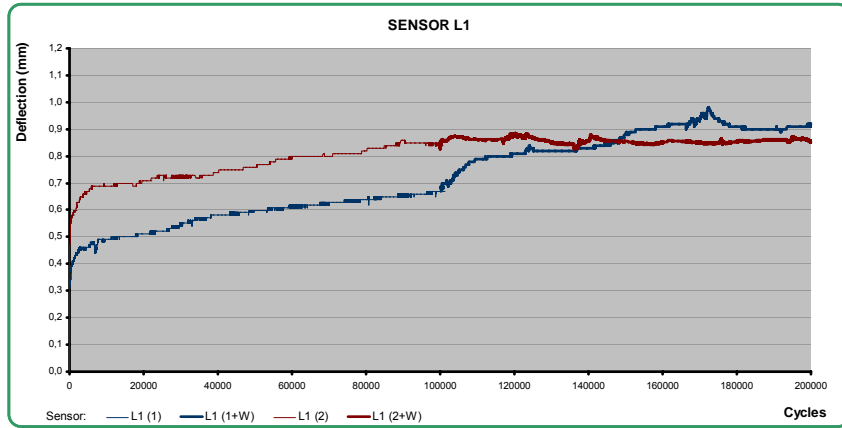

Figure C.5.14: Cumulative results for LVDT sensors

Table C.5.8 shows the deflections at the beginning of loading and at the end of loading the pavement, minimal, maximal and the range of different pairs of deflections.

Bedding layer: sand; deflections in mm						
LVDT	L1	range	L2	range	L3	range
start	0.30	0.37	0.31	0.48	0.26	0.30
end	0.67		0.79		0.56	
min	0.30	0.37	0.31	0.48	0.26	0.30
max	0.67		0.79		0.56	
Bedding layer: sand; watering; deflections in mm						
LVDT	L1	range	L2	range	L3	range
start	0.67	0.25	0.80	0.30	0.56	0.34
end	0.92		1.10		0.90	
min	0.67	0.31	0.79	0.37	0.56	0.39
max	0.98		1.16		0.95	
Bedding layer: screed; deflections in mm						
LVDT	L1	range	L2	range	L3	range
start	0.42	0.42	0.44	0.41	0.43	0.37
end	0.84		0.85		0.80	
min	0.42	0.44	0.44	0.43	0.43	0.39
max	0.86		0.87		0.82	
Bedding layer: screed; watering; deflections in mm						
LVDT	L1	range	L2	range	L3	range
start	0.83	0.03	0.85	0.03	0.81	-0.03
end	0.86		0.88		0.78	
min	0.82	0.06	0.85	0.06	0.77	0.07
max	0.89		0.91		0.84	

Table C.5.8: Deflections and their ranges

The effects of water poured into the pavements were three-fold. There was no effect observed for simulating the light rain. When simulating the extreme rain for the first time, there was a short-term effect on the pavement deflections increase. The result of the second extreme rain was in a considerable prolongation of duration of the effect or/and in the increase of deflection values. As can be seen from Table C.5.9, there was almost no difference in the effect of the two “heavy rains” on the pavement with screed bedding layer. Also, there was a limited effect of watering this pavement. Pavement with the sand bedding layer was affected in much different way. Increase in deflections caused by the first “heavy rain” was the same as for the other pavement, only that the duration was shorter. On the other hand, the second “heavy rain” affected the pavement for much longer time and with considerable increase in deflections compared to the first “heavy rain” and to the other pavement.

bed layer	watering	range (cycles)		peak (cycles)	duration (hours)	effect (mm)
sand	first	23000	25300	24000	2.5	0.02
	second	66400	82300	72000	17.7	0.05
screed	first	16900	23600	20400	7.5	0.02
	second	37700	44600	40600	7.7	0.02

Table C.5.9: Effects of simulating rain

There was an imprint of the test wheel that was observed after finishing the tests on the pavements. The profile of the imprint was measured in five lines with results presented in Table C.5.10. It was found out that about a week time after finishing the tests on the pavement the poroelastic layer returned into its initial position making the wheel imprint not any more visible.

Max deflections (mm)	Line 1	Line 2	Line 3	Line 4	Line 5
without water	1.66	1.77	2.65	3.96	2.30
pavement watering	2.92	2.14	2.84	4.33	2.63

Table C.5.10: Wheel imprint profile lines

### 10.3.8 CONCLUSIONS AND RECOMMENDATIONS

The aim of tests was to solve some problems of a pavement with poroelastic surface that were encountered during previous experiments. ZAG focused on the bedding layer onto which the cement concrete blocks were placed. A decision was also to choose a pavement structure where poroelastic layer is put on concrete (paving) blocks. In this way the critical gluing was made in more controlled and proper manner and environment, in laboratory. The entire pavement structure was designed to be as “strong” as possible to avoid bearing capacity failures, but the intention was also to have it as traditional as possible.

Although the concrete blocks were laid into the sand layer and compacted as much as possible, it seems that the load applied to the pavement was distributed much more uniformly to lower layers through the screed bedding layer than through the sand layer. This is attributed to higher stiffness and compactness of the screed layer, compared to the sand layer. Registered deflections of the pavement with concrete blocks on screed bedding layer were relatively very uniform, what was not the case with the sand bedding layer pavement. Even if the pavement with screed bedding layer has been deforming under load applied more than the pavement with sand bedding layer for the first part of experiment, the trend changed radically and deflections of this pavement stayed almost at the same level throughout the next part (when water was poured into the pavement). Contrary, deflections of the sand bedding layer pavement increased for all the loading time ending with the deflections (much) higher than the other pavement. There was a limited effect of watering the pavement with screed bedding layer and almost no difference in the effect of the two successive “heavy rains”. On the other hand, the second “heavy rain” affected the pavement with the sand bedding layer for much longer time and with considerable increase in deflections compared to the first one and to the other pavement.

All together the pavement where concrete blocks with poroelastic cover were placed into a cementitious screed layer has shown considerably better performance under applied conditions, compared to the sand bedding layer pavement. Considering these results it is advisable to continue with further experiments on this pavement. The research should be oriented to the field tests focusing on stability and suction forces under the typical traffic conditions.

### REFERENCES

- [1] Meiarashi, Seishi (2005): "Noise Reduction Effect of Porous Elastic Road Surface and Drainage Asphalt Pavement". Presentation by Dr Meiarashi (PWRI) at the Japan-Sweden workshop in Osaka, May 2005, organized by NILIM & PWRI, Tsukuba, Japan.
- [2] Sandberg, Ulf; Kalman, Björn; Nilsson, Roger (2006): “Design Guidelines for Construction and Maintenance of Poroelastic Road Surfaces”. Report No. SILVIA-VTI-005-03-WP4-300306 for the EU-project SILVIA. Available from the SILVIA website or from Swedish National Road and Transport Research Institute (VTI), Linköping, Sweden.
- [3] Sandberg, Ulf; Kalman, Björn; Nilsson, Roger (2006): “Design Guidelines for Construction and Maintenance of Poroelastic Road Surfaces”. Report No. SILVIA-VTI-005-02-WP4-141005 for the EU-project SILVIA. Available from the SILVIA website or from Swedish National Road and Transport Research Institute (VTI), Linköping, Sweden.

### **10.4 Development of high performance underlayers with low cost materials and high percentage of re-use**

Nicolas BUECHE (EPFL – LAVOC - Switzerland)  
Ann VANELSTRAETE (BRRC -Belgium)

One of the ideas in the framework of sustainable road construction worked out in NR2C concerned the development of high stiffness base layers with high percentages of re-use materials. Although high stiffness base layers are already extensively used in some European countries, the experience with re-use in such mixtures is still very limited. There is indeed a fear for a limited durability of these mixtures because of the combination of a hard binder (which is typical for these mixtures) and re-use material.

#### **10.4.1 MATERIAL CHARACTERISATION AND MIX DESIGN**

High stiffness modulus mixes were prepared with Belgian as well as with Swiss materials. One and the same hard binder 10/20 was used through the whole study. Its characteristics are given in table C.1.1 [2]. The mixes with the Belgian materials were used for extensive laboratory testing. These tests provided information for the designs to be made with the Swiss materials, which were applied on the LAVOC ALT (accelerated loading testing) facility.

Type	Pen [1/10mm]	R & B [°C]	Binder content [%]
Belgian RA	17	67.3	5.5
Swiss RA	32	59.4	4.8

**Table C.1.1:** Characteristics of the hard binder 10/20.

The BRRC software PradoWin was used for the mix designs and optimization. PradoWin is a user-friendly program, adapted for the volumetric mix design of bituminous mixtures, and with a special feature to facilitate the mix design of mixtures with re-use materials. The required input data (the characteristics of the constituent materials) were determined by BRRC [3]:

High stiffness mixtures for base layers can be achieved by using a high percentage of stones and a hard binder. Together with an increased binder content compared to a conventional dense asphalt composition suitable for base layers, this allows to design, despite of the high percentage of stones, relatively dense mixtures with a good coating of the aggregates and hence, a good performance in durability.

Two basic mix designs were made:

- one mix design with Belgian materials,
- one mix design with the Swiss materials to be used in the ALT study.

Different variants (with different percentages of RA) were designed, based on approximately the same grading curve:

- Variant 1: Design without RA (reference).
- Variant 2: Design with 25 % RA.
- Variant 3: Design with 40 % RA.

The analytical mix design was combined with subsequent gyratory compaction tests according to EN12697-31 to verify the compactability and the air void content. Depending on the results of the gyratory tests, the analytical mix design was adapted.

Table C.1.2 shows the final mix gradings for the various variants. The percentage of RA given in table C.1.2 stands for the percentage of old binder (from RA) on the total binder content.

	Mixes with Belgian materials			Mixes with Swiss materials		
% RA	<b>0</b>	<b>25</b>	<b>40</b>	<b>0</b>	<b>25</b>	<b>40</b>
% total binder	5.5	5.5	5.5	5.8	5.8	5.8
% RA aggregates	0	24.3	39.4	0	29.5	47.4
% passing on sieve						
20 mm	100	100	100	100	100	100
14 mm	97.3	96.8	96.4	97.7	97.0	96.7
10 mm	75.4	75.5	74.9	76.4	76.2	79.2
6.3 mm	52.1	53.9	54.1	57.5	55.3	59.5
4 mm	37.9	40.3	41.1	43.8	41.5	45.1
2 mm	30.5	32.0	32.3	33.0	30.3	32.1
1 mm	21.9	24.6	25.8	25.6	22.7	23.2
0.5 mm	16.0	18.9	20.5	21.2	17.9	17.5
0.25 mm	11.1	13.1	14.2	17.5	14.1	13.0
0.063 mm	5.9	6.0	6.1	6.3	6.3	6.4

**Table C.1.2:** Grading of the different mixtures

#### 10.4.2 LABORATORY PERFORMANCE OF THE MIXES

An extensive laboratory study was then performed on all mixtures to check the laboratory performances:

- Stiffness modulus was determined according to EN12697-26 annex A (two-point bending test on trapezoidal samples) for temperatures between -20 °C and 30 °C and for frequencies between 1 and 30 Hz.
- Resistance to fatigue of the different mixes was determined according to the BRRC-method [4] (two point bending test on trapezoidal samples) at 15 °C and 10 Hz. This test method is close to EN12697-24 annex A, but is stress controlled and performed on large samples.
- Resistance to permanent deformation is determined according to EN12697-22 (large device in air) at a temperature of 50 °C.
- Water sensitivity is determined as the indirect tensile strength according to EN12697-23 before and after conditioning in water according to EN12697-12.

The results are given in table C.1.3. We note that for the Swiss mixtures with RA, some of the tests were performed with a lower binder content (5.7 and 5.6 % for 25 % and 40 % of RA respectively, instead of 5.8 %). The reason for this is that in an asphalt plant, the variations on binder content of RA are usually larger than in the laboratory. With a high percentage of re-use, the impact of this parameter on the total binder content is important. A way to deal with this uncertainty in the phase of mechanical performance testing is to make the tests with the most unfavourable estimation of the binder content. For the mix with 40 % of RA, a variation of 0.5 % on the binder content of the RA would lead to a variation of 0.2 % on the total binder content. By doing some tests with a total binder content of 5.6 % instead of 5.8 %, the laboratory tests will be on the safe side.

	Mixes with Belgian materials			Mixes with Swiss materials		
% RA	0	25	40	0	25	40
% total binder	5.5	5.5	5.5	5.8	5.8	5.8
% voids gyratory (100 gyr.)	3.3	3.8	2.7	3.3	3.2	1.8
Rut depth [%] at 30'000 cycles, 50 °C	2.7	-	-	3.0	2.5	2.8
ITS-testing Voids [%] (hydrostatic)	3.3	2.8	2.4	3.7	5.0 (*)	6.0 (**)
Strength before [MPa]	2.5	2.3	2.4	2.3	1.5 (*)	1.3 (**)
ITS-ratio	98 %	95 %	101%	92 %	104% (*)	94 % (**)
Stiffness modulus [MPa] at 15 °C - 10 Hz	12740	-	12830	13900	12460 (*)	12050
Fatigue [15 °C, 10 Hz]						
Slope a	0.156		0.146	0.097	-	0.131
ε6 (μstrain)	123.4	-	120.1	143.2	-	123.7
N for ε = 120 μstrain	1.2 X 10 <sup>6</sup>	-	1.0 X 10 <sup>6</sup>	6.2 X 10 <sup>6</sup>	-	1.3 X 10 <sup>6</sup>

(\*) determined for 5.7 % binder content instead of 5.8 % to investigate the risk of durability loss

(\*\*) determined for 5.6 % binder content instead of 5.8 % to investigate the risk of durability loss

Table C.1.3: Laboratory performance of the different variants

It was concluded that a high laboratory performance was reached on all aspects:

- All mixes have a very high stiffness around 12'000 – 13'000 MPa at 15 °C and 10 Hz.
- The resistance to permanent deformation is very high: always below 5 %. Note that this is the lowest value (best performance) according to the European specifications in EN1308-1.
- The resistance to the action of water is very high: for all mixes above 90 %, which shows that durability problems are not to be expected.
- The resistance to fatigue is very high: above 1.0 x 10<sup>6</sup> cycles at 120 microstrain. This is at least a factor seven better than a conventional Belgian mix for underlayers.
- The void content (measured hydrostatically) of the Swiss mixes with 25 % (binder content 5.7 %) and 40 % RA (binder content 5.6 %) is rather high: 5 % respectively 6 %.
- Mixes with reclaimed asphalt have equivalent performance as mixes without RA.

### 10.4.3 ACCELERATED LOADING TESTS

The accelerated loading tests have been performed in LAVOC's facility. Using this facility, the different mixtures have been tested in an accelerated way by controlling different parameters. In addition to the ALT, some other tests on in situ mixes have been performed with the aim of providing additional information for a better performance analysis.

#### Accelerated loading tests setup

The selected solutions were tested in full-scale accelerated loading testing (ALT) facility of LAVOC. They have been applied in a test section which dimensions are 13.1 m x 5.4 m (circulation direction). The pavement design has been carried out using two specific pavement design softwares based on

the multilayer theory of Burmister: the Belgian software DimMET (developed by BRRC and Febelcem for the Walloon Ministry of Equipment and Transport) and a French design method with the help of the NOAH software. For this pavement design, the aim was to have a structure which is expected to reach the end of its design life after 2/3 of the planned passages. More details can be found in [5].

The tested structure, represented in figure C.1.1, is as follows:

- Layer 1: AC MR8 (3 cm),
- Layer 2: High Modulus Asphalt (8 cm),
- Layer 3: Soil foundation composed by gravel 0/60 (40 cm), fine sand (145 cm) and concrete.

Four different sections have been studied, with various HMA contents: a reference without RA (field 0), a section with 25 % of RA (field 1) and two sections with 40 % of RA of which one doesn't include a wearing course (field 3).

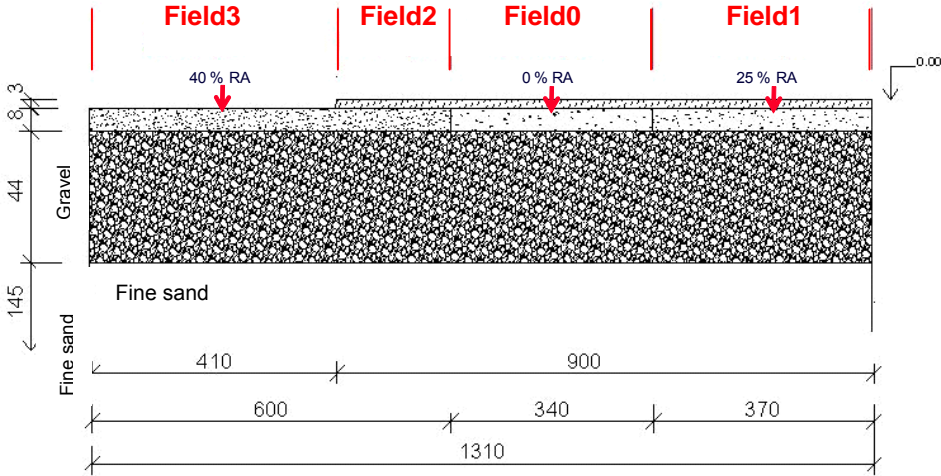

Figure C.1.1: Cross section view of the tested pavement

The sections have then been loaded with a heavy traffic simulator (axle load of 12 tons, tyre pressure of 0.8 MPa and super-single tyre), which simulates traffic close to in situ conditions. In order to tests the different pavement types, three positions of circulation have been defined (figure C.1.2):

- Position A: Two wheels on field 3 with 40 % RA, no top layer (axles A1 and A2)
- Position B: One wheel on field 2 with 40 % RA (axle B1) and one wheel on reference field 0 (axle C1)
- Position C: One wheel on the reference field (axle C2) and one wheel on the field 1 with 25 % RA (axle D1)

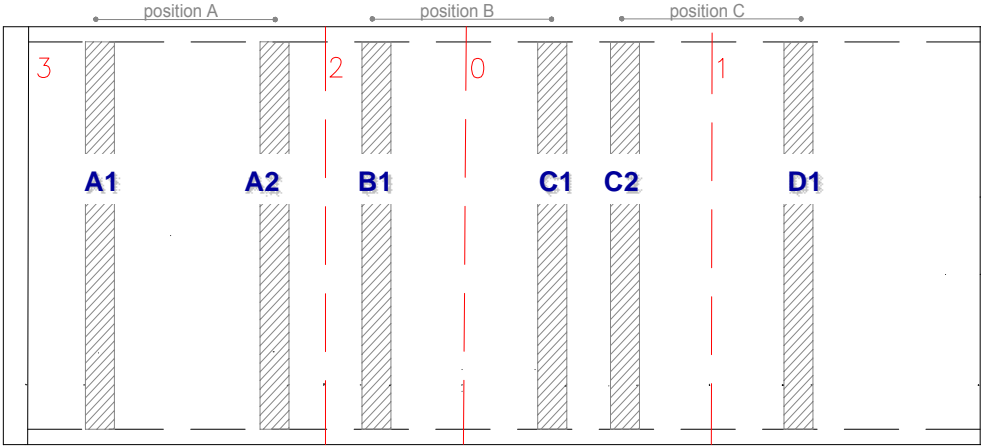

Figure C.1.2: Positions of circulation for ALT testing

In order to measure horizontal stress and strain as well as temperature, different sensors have been installed at the bottom of the HMA and also at the interface between HMA and top layer. For temperature measurements, classical Pt100 have been used. Deformation measurements have been achieved using KYOWA strain gauges. A total number of 57 sensors have been installed in the pavement.

In addition to these sensors, surface deflection has been measured using a specific deflection beam instrumented with LVDT sensors (Figure C.1.3). Using this device, measurements close to the wheel passage have been performed.



Figure C.1.3: Specific deflection beam used in the ALT facility

The behaviour of the different sections has been assessed through two following test phases:

- In a first part, fatigue tests have been performed at a constant air temperature of 15 °C. During these fatigue tests, about 100'000 wheel passages have been performed on each position except position A that has got a total of 190'000 fatigue passages.

- The fatigue tests have then been followed by low temperature tests (LT). The aim of the second test phase was to simulate temperature cycles with circulation as well. Hence, air temperature variations between 2 °C and -7 °C were applied during 12 day for each position of circulation. In order to have a good temperature control, an isolated cabin with a cooling system using ventilators has been applied.

### **Results and analysis of the ALT**

A total of more than 370 measurements have been performed during the whole test duration. For an assessment of the fatigue resistance of the different mixtures, special emphasis has been put on the deformations at the bottom of the asphalt layer. Traction is effectively most important at the bottom of the HMA and fatigue cracking will most likely occur at this interface [6].

Different comparisons between the mixtures have been carried out with the aim to assess if there is any negative effect using mixes with a high percentage of reclaimed asphalt instead of a mixture without RA. Parts of the results and the conclusions are presented hereafter, more details can be found in [7].

#### *Comparison between 25 % RA and 0 % RA*

In following figure C.1.4, each gauge is represented by a line while the code indicates the measurement axle C2 (0 % RA) or D1 (25 % RA). The first 100.000 passages correspond to the fatigue tests at 15 °C while the passages performed between 100.000 and 210.000 correspond to the low temperature tests (LT).

It is obvious that the general trend is the same for both axles i.e. both mixes. The small differences observed are not significant enough for concluding to a much better behaviour of the section with 25 % RA, but show that its resistance is at least the same as that of the reference mix. Moreover, the general order of magnitude for the deformation decreases during the low temperature tests. This was

expected because by reducing the temperature, the pavement becomes stiffer and consequently the deformation decreases.

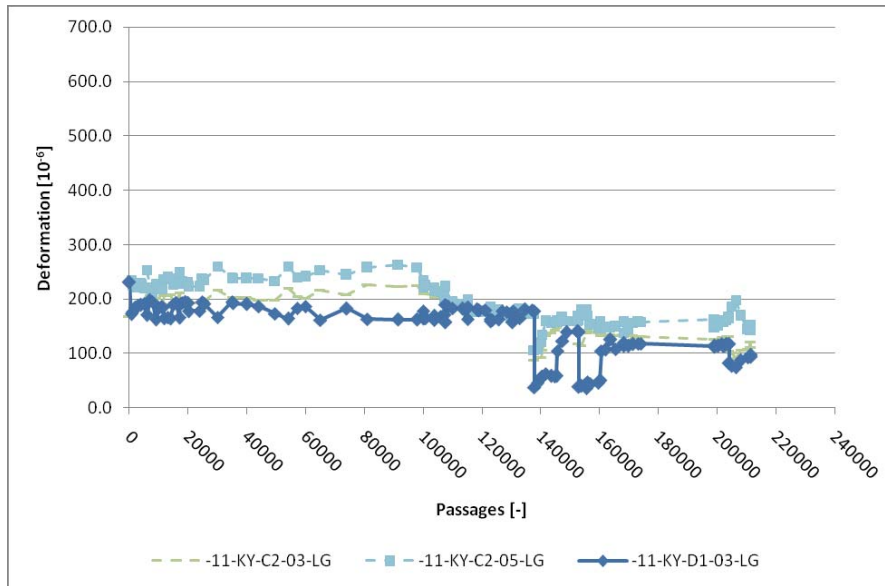

Figure C.1.4: Comparison between the performance of axle C2 (0 % RA) and D1 (25 % RA)

*Comparison between 40 % RA and 0 % RA*

The same comparison has been carried out for the mixtures with 40 % RA (axle B1) and the reference mix without recycling material (axle C1).

In figure C.1.5 below, the general trend shows a decreasing of the deformation during low temperature tests (between 100.000 and 190.000 passages) that was expected, but the order of magnitude is slightly bigger than for previous comparison with deformation up to 300 µε. Comparing both mixes, the measurements on the section with the reference mix are a bit lower than with the mix containing 40 % recycling material. However, the differences measured are very small and they cannot be considered as a conclusion about a major behaviour difference between the mixes.

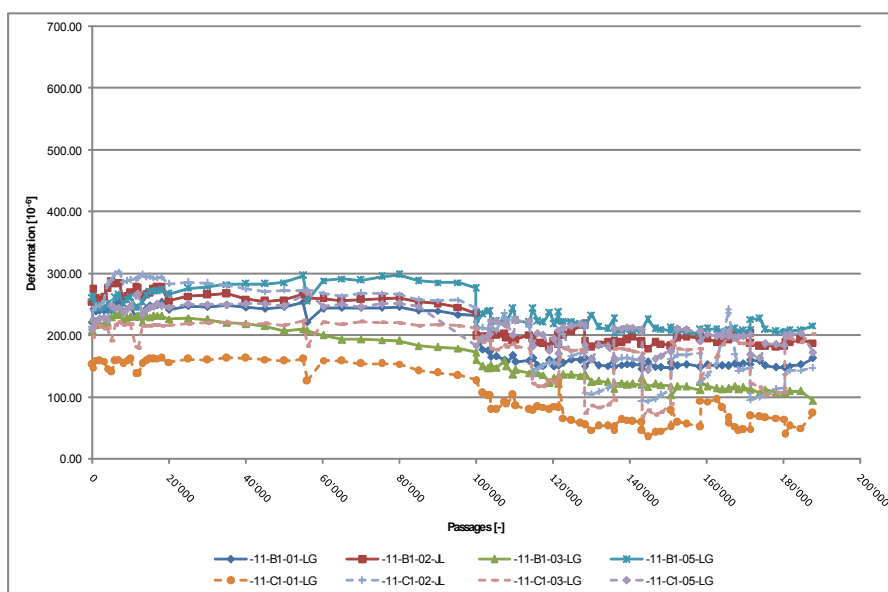

Figure C.1.5: Comparison between the performance of axle C1 (0 % RA) and B1 (40 % RA)

Considering both comparisons above between the different mixes, we can conclude that the same order of magnitude has been measured for the deformation in the mixes without and with RA. The general trend of slightly lower deformation in the section with 25 % RA is not sufficient enough in order to deduce a difference in fatigue resistance.

In addition to the different measurements, some calculations have been performed using the NOAH software. These calculations have been carried out at the end of the tests with the aim of providing some additional information about the different material behaviour and an assessment of the difference between calculations and measurements. Moreover, this has been used in order to assess the quality of the measurements in comparison with theoretical values.

For this part of the study, updated values obtained through laboratory tests have been considered in order to have accurate material characteristics. In fact, a few points with stabilized temperature have been chosen and the calculation compared with the measurements for these selected points, considering the elastic modulus in function of the layer's temperature registered.

The outputs of these calculations were very interesting and quite good correlations with measurements have been found. In some cases, less than 15 % difference has been calculated. Considering all the input parameters that influence the calculation (in situ material not necessary the same as laboratory samples, consideration of fatigue effect, Burmister theory, ..) the results obtained are in good agreement with the measurements. Moreover, the additional calculation permitted to make a sensitivity analysis on the bonding conditions and the effect of the top layer, as well.

Figure C.1.6 gives an example of the calculation results. In this figure, the calculated points are represented with red dots.

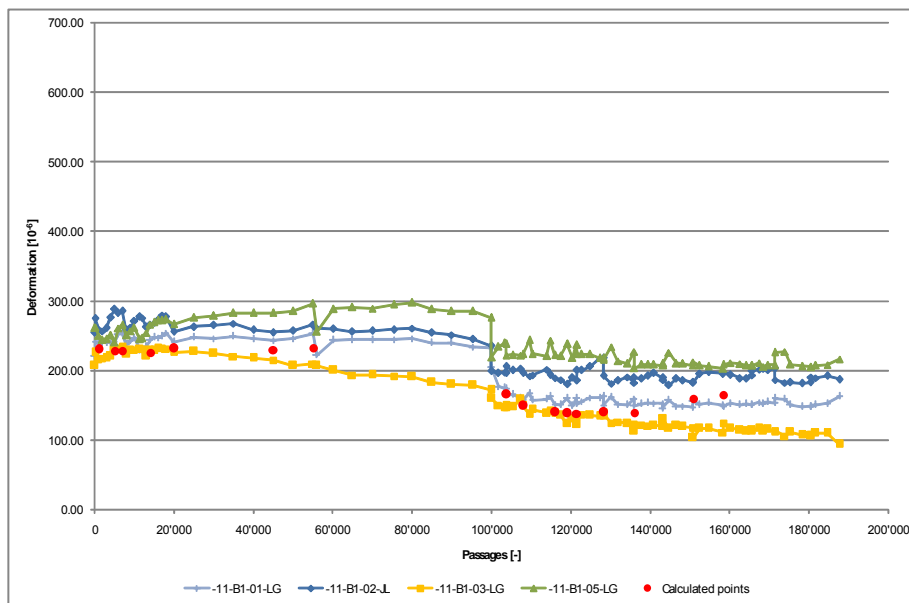

Figure C.1.6: Comparison between calculated and measured deformations for axle B1 (40 % RA)

We can conclude from the ALT study and additional calculations that no negative effect of a high percentage of RA has been observed. Indeed, the mixes with RA showed at least equal performance as the mix without recycling material. Moreover, the tests conducted reached a performance rate and load repetition that is high enough for concluding that the behaviour of the mixes is very good.

#### 10.4.4 OTHER TESTS RELATED TO ALT

In addition to the ALT, additional tests and analysis have been performed on in situ mixes. They are discussed hereafter. More details can be found in [7].

### Wheel tracking tests

Wheel tracking tests have been conducted on laboratory mixes during the mix design. In order to assess the resistance to rutting of the in situ mixes that have been tested through ALT, different slabs have been constructed during the laying phase. These slabs have then been tested at 50 °C according to the EN 12697-22. Moreover, the rutting resistance under severe conditions have also been assessed through a test at 60 °C. Indeed a test with extreme temperature has been found relevant as it would be possible to have HMA base layers that could reach very high temperature in some southern European countries, for instance.

The tests results showed very good performance regarding rutting for all mixes. Indeed, the proportional rut depth at 30'000 cycles was always under the limit of 5 % which corresponds to the best category for the future European method at 50 °C (EN 1208-1).

The tests at 60 °C permitted to confirm the very good resistance of the different materials regarding rutting, even with severe conditions. Indeed proportional rut depths close to 5 % have been measured.

### Tests on cores

Different coring campaigns were carried out during the tests at the ALT facility: before the beginning of the tests, after the fatigue tests and at the end of the low temperature tests, as well. On these cores, following tests have been performed and compared with the laboratory tests performed during the mix design:

- Bulk density (EN12697-6, procedure B)
- Maximum density (EN 12697-5, procedure B)
- Water sensitivity (EN 12697-12)
- Stiffness according (EN 12697-26, method IT-CY at different temperatures)

These tests on cores came to the same conclusion as obtained during the mix design i.e. no negative effect of a high percentage of recycled material [7]

### Binder analysis

Making a study with reclaimed asphalt, the behaviour of the binder and especially the mix of old and new binder are also important. In order to assess these parameters, a specific study of the binders was carried out and different conditions selected:

- Raw binder with and without ageing
- Binder recovered from RA
- Binder laboratory mixes and ageing using RTFOT
- Binder recovered from in situ mixes
- Binder recovered from laboratory mixes.

Classical tests (pen, R&B) have been performed for each binder condition but also rheological tests like DSR. This analysis showed that the different laboratory and in situ mixes are consistent as rather comparable values have been found. This study also demonstrated that RTFOT ageing corresponds rather well with laboratory production ageing whereas field ageing seemed to be more severe. This can be linked with the high production temperatures.

### Tests on big slabs

A specific test in controlled conditions has been performed on big slabs taken in the ALT facility. While the tests in the ALT facility focused on fatigue testing at 15 °C and low temperature tests, it has been decided to investigate the mix behaviour at elevated temperatures. Hence, three large slabs were extracted from undisturbed areas and sent to DRI for testing in the Danish Asphalt Rut Tester (DART). These devices permitted to simulate a rolling load with side wander random normally distributed [7].

For the tests in DART on big slabs, a standard testing has been conducted with 50 kN wheel load and 110.000 load applications. The results have then been compared with the results obtained on Danish motorway pavements. After first tests according to the standard procedure, a further 44.000 loads were applied at an elevated temperature of 50 °C surface temperature / 40 °C bottom temperature, this in order to be sure to reach rutting and analyze the limits of the material, as well. The permanent deformation evolutions for the three slabs are illustrated in figure C.1.7:

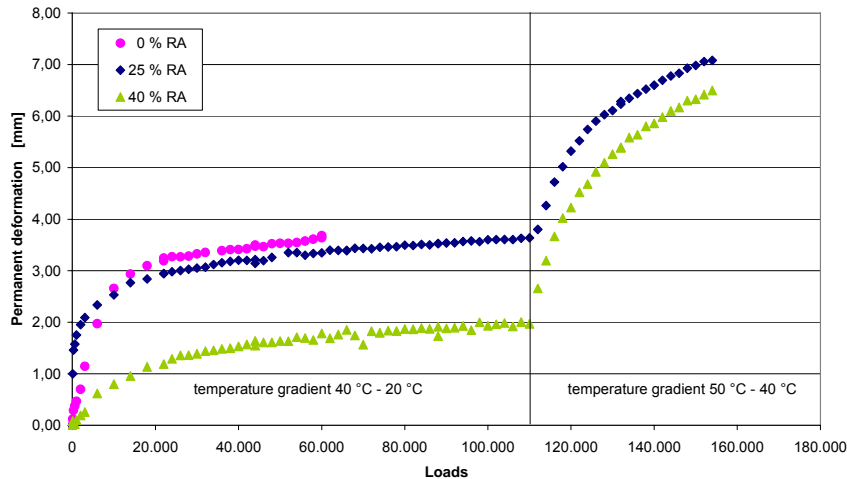

Figure C.1.7: Rutting behaviour for the three tested slabs

As the deformation obtained during the first 20'000 loads will to some extent mainly depend on initial compaction under the wheel load, it cannot be concluded from these data that rutting of the slab with 40 % RA is much less pronounced than for the other two slabs. For a comparison of rutting behaviour of different slabs without this initial disturbance, the increase of rutting from 20'000 to 40'000 loads is calculated. For the different slabs, we obtained a rutting increasing between 0.25 mm (25 % RA) and 0.32 mm (0 % RA). Comparing these results with the Danish standards on highways (between 0.5 and 5 mm), we conclude that rutting susceptibility is much better than for standard motorway pavements. Moreover, no significant difference between the different slabs can be determined. Concerning elevated temperature tests, the slab with 40 % RA had a slightly but not significantly faster rutting development than the slab with 25 % RA.

#### 10.4.5 CONCLUSIONS AND RECOMMENDATIONS

In this innovation, a sophisticated methodology has been used, based on a mix design software, different laboratory performance tests and also ALT testing. Hence, a lot of performance characteristics under several circumstances have been investigated through these tests, to obtain as much as possible information about the performances of the different mixes.

High performance mixtures were obtained with equivalent performance for mixes with RA than mixes without RA, provided that an optimization of the mix design was performed based on the analytical mix design study and on the results of the performance tests. Three designed mixtures were further tested in the ALT-testing facility of LAVOC. No failure was observed in these experiments, and mixes with RA showed equivalent performance as mixes without RA. It was shown that the use of high percentage of reclaimed asphalt in base layers has no negative effect on the laboratory mix performance. ALT, wheel tracking tests, tests in DART and also laboratory tests on cores and binders samples came to the same conclusion that no negative effect of a high percentage of RA could be identified so far.

However, it is important to keep in mind that such a conclusion cannot be extended to all the HMA mixes. Some parameters like the grading curve, recycling material and binder type play a key role in the final properties. Considering these elements, it is recommended to put special attention on the characterisation of the reclaimed asphalt, on the mix design and on the laboratory tests, in order to fully guarantee performance.

According to the results obtained and the good results with the different mixes, it is advisable to make some in situ tests that would permit to validate the results of this research. Another important question is where to put the efficient limit concerning the RA content. Obviously, the encouraging results obtained allow us to think about 50 % or 60 % recycling material. However, further increase of RA content will necessitate a very good control of some parameters such as viscosity may require the use of new techniques as well.

## REFERENCE

- [1] A Junod and P Bauweraerts, NR2C-report "Deliverable 2.1: State of the art of interurban infrastructure design, construction and maintenance", May, 2005
- [2] A. Vanelstraete and P. Peureaux, NR2C-report "Summary of results of the new binder", February, 2006
- [3] A. Vanelstraete et al., NR2C-report "Phase 1: Mix design and performance assessment with Belgian materials", June, 2006
- [4] BRRC, Test method OCW/CRR-IX-02 "Determination of the resistance to cracking by fatigue"
- [5] J. Maeck and N. Bueche, NR2C-report "Innovation 2.1A: Structural design", July, 2007
- [6] J. Perret, Thèse LAVOC "Déformations des couches bitumineuses au passage d'une charge de trafic", 2003
- [7] N. Bueche et al., NR2C-report "Deliverable 2.2 Technical report Innovation 2.1A "Development, assessment and application of innovations for interurban infrastructures", September, 2007

## 10.5 Crack-free semi-rigid pavement incorporating two industrials by-products

Thierry SEDRAN (LCPC - Nantes)

### 10.5.1 GENERAL SCOPE OF THE INNOVATION

In semi-rigid pavement structures, the well graded treated aggregate used as a base course always present transversal cracks because:

- it is submitted to different shrinkages: desiccation in the first months and thermal shrinkage during its all life;
- its shrinkage is restrained by the sub-base
- it's a rigid material, with an elastic modulus generally higher than 20 GPa.

Due to the traffic and the weathering, the longitudinal cracks inevitably reflect themselves in the wearing course. When the cracks are wide-opened, the interlocking of the pavement blocks on the both sides of the cracks is limited and then the structural efficiency of the pavement is lessened. Moreover, these cracks damage the aesthetic, the evenness and the comfort of the wearing course. They finally facilitate the penetration of water, which accelerates the ageing of the structure.

That is why regular maintenance (cracks silting up) is generally needed, approximately each 3 years. Yet, although it is efficient on the structural point of view, it does not solve the aesthetic and evenness matters. Moreover, maintenance works disturb the road users and represent an important cost.

So cracking appears less and less acceptable by the construction financing authorities and different strategies were developed to avoid its appearance:

- pre-cracking system in the construction phase. Thanks these techniques, it is possible to control the position of the cracks, then to limit the space between two cracks (around 2 meters) and consequently the thickness of the cracks;
- interface anti-cracking systems which try to block the cracks under the wearing course;

Unfortunately, the efficiency at long term of these techniques is not completely demonstrated and generate extra-cost at construction.

In conclusion, well graded aggregate is a durable material but its cracking tendency limits the life duration of semi-rigid pavement structure. So it would be interesting to develop crack free well-graded treated aggregate to obtain long life semi rigid pavement with low maintenance cost. The scope of this innovation is to evaluate the feasibility of such a material thanks the use of two by-products.

The idea is the following:

- some by-products like steel slag display spontaneous swelling behaviour and release lime;
- pozzolans like fly ashes react with lime to give hydrates (CSH) and mechanical properties;
- optimized mixtures of such swelling by-products with inert materials and pozzolans could present structural properties in combination with a controlled swelling, which could overcome the thermal shrinkage.

If such mixtures could be realized, they would allow:

- construction cost savings (as a part of the components are by-products);
- maintenance cost savings (no cracks means thinner structure and no joint maintenance);
- high quality materials savings (by the use of by-products).

These goals are in perfect accordance with the main objectives of the Innovation task which are low cost pavement construction and maintenance techniques.

## 10.5.2 C.2.2 BIBLIOGRAPHICAL SEARCH

During the production of iron and steel, the iron oxides and some of the metal oxides are reduced forming the metal melt. The remaining oxides will be bound into an oxide melt: the slag. The production of iron and steel is normally carried out as a series of discrete operations with essentially: the reduction in the blast furnace, the steel process using the Basic Oxygen Furnace (BOF) and Electric Arc Furnace (EAF) process following by the finishing of liquid steel in the secondary metallurgical treatment.

The pig iron production in the blast furnace leads to the blast furnace slag, which properties can be influenced by the cooling conditions: air cooling generates the crystalline air cooled blast furnace slag (ABFS) and rapid cooling with water or even with air generates the glassy granulated blast furnace slag (GBS). Both produce about 250-300 kg per ton of pig iron made (the European pig iron production are more than 60 million tons in 2005), they are fully used respectively as aggregate in road construction or concrete, and as cement compound or as addition to concrete.

Steel slag is produced from the further refining of iron in a Basic Oxygen Furnace (BOF Slag) or from melting recycled scrap in an Electric Arc Furnace (EAF slag). Both produce about 100 kg per ton of steel made and in Europe every year nearly 12 million tons of steel slags are produced. Owing to the intensive research work during the last 30 years, about 65% of the produced steel slags are used on qualified fields of application, today. But the remaining 35% of these slags are still dumped. In France, the dumping rate of steel slags is close to 25 %, for an annual production close to 1.7 million tons (in 2005).

Owing to their physical, chemical and mineralogical properties, the steelmaking slags are suitable for various kinds of applications in industrial areas. EAF slag is basically used in road construction (as layer with or without binder) and earthworks (road cover, road base, way's consolidation) and their high resistance to wear successfully promoted their use as mineral aggregates for wearing course in road surfaces. BOF slag has been previously used in the blast furnace to recover the iron in the slag and as lime carrier. Due to the extent requirements on the phosphorous content of steel, BOF slag recycling became more and more restricted and new applications had to be found. BOF slags are used in road construction, as aggregate for concrete or for hydraulic engineering, as fertilizer in agriculture, as pollutant removing filter or soil stabilization.

The BOF- and EAF-slags from different sources within Europe, are generally comparable and independent of their producers. Differences arise from the use of dolomite rather than lime as fluxes with the effect of a higher MgO-content in the slag. BOF- and EAF-slags are calciumsilicatic with a range of CaO between 42 and 55%, and a range of SiO<sub>2</sub> between 12 and 18%. EAF-slags comprise CaO between 25 and 40% and 12 to 17% SiO<sub>2</sub>. Their MgO-content may be higher due to the reactions with the refractory lining. The main mineral phases of BOF- and EAF-slags are dicalciumsilicate, dicalciumferrite and wustite. The content of free lime and free MgO is the most important component for the utilisation of steel slags for civil engineering purposes, with regard to their volume stability. In contact with water, these mineral phases will react to hydroxides. Depending on the rate of free lime and/or free MgO hydration, it causes a volume increase of the slag mostly combined with a disintegration of the slag pieces and a loss of strength. So, the volume stability is a key criterion for using steel slags as a construction material.

Then, for many steelworks, a significant proportion of this slag will be landfilled, and of the materials dumped, it will often form the largest proportion. With increasing pressure in many countries for greater use of secondary aggregates to preserve the natural resources, steel slags offer a promising and relative abundant alternative. During the last twenty years, the problem of volume stability was the main objective of the research work on steel slag in Europe. Today, this problem can be avoided with a suitable weathering of the slag in order to favour the free lime hydration. Such slag can then be safely treated with bituminous binder for road wearing course notably. Moreover, steelmaking slags can be used at all levels (unbound in the lower layers, bituminous-bound in the upper courses, and as a surface dressing) (Piret et al., 1982). Yet the slag maturation still remains problematic because of the associated handling or the pressure imposed by the environmental policies. This is why, it is today necessary to promote a new approach for the valorisation of steel slag in civil engineering, considering slags of lower quality and trying to convert slag disadvantages into positive aspects.

The combination of BOF slag (with or without weathering) with other materials is another way to limit the volume instability. Numerous studies dealing with the composition of mixes of BOF slag aggregates with other materials, such as granulated blastfurnace slag, municipal solid waste incinerator bottom ash, fly ash, used for road construction can be found in the literature. For example, by mixing 70-85 % of weathered BOF slag with 15-30 % of granulated blastfurnace slag, a road base was produced without significant expansion damage. Moreover, a slowly setting composition is obtained which provides, at low cost, a quality road base which can be considered as semi-rigid in comparison with concrete bases (Piret et al., 1982). Best (1987) developed a well graded composite similar to the French 'graves-laitier', but containing both air-cooled blast furnace slag (5-20 mm, 57 vol.%), LD slag (0-5 mm, 28 vol.%) and quenched blast furnace slag (15 vol.%). The cementitious action of the quenched blast furnace slag, activated by the free lime embedded in the BOF slag binds the mix. Such a pozzolanic reaction consumes the free lime non-expansively, lowering the tendency of the aggregate for expansion. This new material referred to as "self-binding slag composites" presents the advantage to minimise the need of chemical activators owing to the free lime present in the slag. Juckes (1991) confirmed that the dilution of the BOF slag and the associated cementitious reaction lead to a limited expansion of such mixes, arguing in favour of an absorption of the expansion attributed to the BOF slag aggregate by the semi-rigid environment. This was recently shown again in a recent study made by Tikkaoski et al., (2005).

In these previous studies, the mix optimization was carried out in the laboratory by seeking the best geotechnical performances. It was assessed by classical techniques used in road engineering such as measurement of compressive strength, Proctor optimum, CBR, freeze-and-thaw and rutting resistance or volumetric stability. However, from a practical point of view, the use of BOF slag aggregates in road construction remains unusual because of the uncertainties about volume stability. In fact, this volume stability depends on numerous factors such as proportions of the different components, free lime content of BOF slag, residual potential volume increase after weathering. So, whereas such a technique of combination with other granular materials offers a promising way of valorisation for BOF slags in road, it requires more technical specifications and needs development of tools to be able to predict and ensure the volume stability of the obtained mixes.

In that context, Deneele et al. (2005) have proposed a new method to predict the swelling of any combination of swelling aggregate and inert aggregate fractions. This method is based upon the Compressible Packing Model developed at LCPC which was implemented in the software René-LCPC (Sedran and de Larrard 1995, Sedran and de Larrard 1996, Sedran 1999, de Larrard 1999). This software was first developed for the optimization of concrete, but the framework of the model is much more general and can be used for other types of granular packing or granular suspensions. The software needs three types of data for each granular component: the dimensions of the particles (as given by the grading curve), the specific gravity and the packing density. It then predicts, for any combination of the fractions, either the compaction index from the packing density, or the packing density from the compaction index. This latter parameter is a characteristic of the placing method tabulated thanks calibrations (for example, 9 for packing under vibration and 20 kPa pressure). The software was widely validated in the field of the packing density of dry granular mixtures and gives an error lower than 1% in absolute value, in comparison with the experiments.

The authors have verified that the weathering of compacted BOF slag samples in an accelerated test with a steam apparatus (see below) induces swelling and grading changes of the material. The grading change can be directly evaluated by sieving, and swelling can be interpreted as a difference in packing density of the mix before and after weathering. In fact, swelling S% can be expressed as following:

$$S = 100 \frac{V_f - V_i}{V_i} = 100 \left( \frac{C_i \rho_i}{C_f \rho_f} - 1 \right)$$

Where:

- $V_i$  and  $V_f$  are respectively the volume of the sample before and after weathering
- $C_i$  and  $C_f$  are respectively the packing density of the sample before and after weathering
- $\rho_i$  and  $\rho_f$  are respectively the specific gravity of the BOF before and after weathering

Deneele et al. (2005) have then introduced the properties of the different classes of grains of BOF slag into Rene-LCPC for two cases: before and after weathering. From these data, they were able to calculate the packing density before and after weathering of several mixes made of BOF slag and Air-cooled Blastfurnace slag on one hand and BOF slag aggregates and limestone on the other hand. They were then able to calculate a theoretical swelling according to the previous equation. These results confirmed to be in good agreement with the experimental data for mixes containing less than 50% of BOF slag. For higher content of BOF slag, the theoretical swelling was overestimated. According to the authors, this is due to the fact that for high volume of BOF slag, the mixes were less porous so that, during the accelerated swelling test, the steam could not penetrate into the packing and then the experimental swelling was lower than could be expected.

Using the approach proposed in that study, it is then possible to optimize the mix composition of BOF slag with inert aggregate, in order to have an acceptable and limited swelling.

Finally, combining a BOF slag with a fly ash and an inert aggregate could be a good way to obtain a well-graded aggregate with noticeable mechanical properties and a controlled swelling. In fact the fly ash may react as a pozzolan with the lime released from the BOF-slag and the swelling could be controlled by the introduction of an inert aggregate thanks the use of Rene-LCPC.

### 10.5.3 PRELIMINARY FEASIBLY TESTS

Materials selected for this study were:

- a 0-10 mm fresh Basic Oxygen Furnace slag (the same as presented in Deneele et al. (2005)) representative of French production
- a 0/6 mm and a 10/20mm "Le Boulonnais" limestone
- coal fly ashes from Surchiste company
- a quicklime (activator)

A first step is to rapidly identify promising well graded aggregate mixtures producing at the same time some swelling to counteract the effect of the different shrinkages, and noticeable mechanical performances. Both are needed to produce a road layer with bearing capacity and no cracks.

In case of success, the selected mixtures should be tested in the same way but at 20°C and at longer term. In fact, 20°C is more representative of the temperature during the road life, moreover the temperature has a great influence on the chemical reactions involved: expansion of free lime, pozzolanic reaction between lime and fly ash. So the evolution of swelling compared to that of the elastic modulus and tensile strength may change in great proportions compared to tests at 90°C.

In a first approximation we will aim at a splitting tensile strength between 0,5 to 1 MPa which corresponds to GC1 or GC2 class of cement treated well graded aggregate in EN 14227. A rough calculation of swelling to be aimed at, can be made with the following assumptions:

- the well-graded aggregate have a long term splitting strength of 1 MPa and an elastic modulus of 20 000 MPa;
- the well-graded aggregate has a thermal expansion coefficient around  $10 \cdot 10^{-6}/^{\circ}\text{C}$ , and the layer may be submitted to a maximum temperature variation in a range of 30°C (between night and day and summer and winter). This lead to a maximum  $300 \cdot 10^{-6}$  shrinkage between hot period and cold one;
- autogeneous shrinkage of the well graded aggregate is negligible and its drying shrinkage is around  $300 \cdot 10^{-6}$ .

The well graded aggregate is then submitted to a maximum  $600 \cdot 10^{-6}$  strain, yet the acceptable strain at long term before cracking is  $1/20000 = 50 \cdot 10^{-6}$ . So the swelling should be at least  $250 \cdot 10^{-6}$ . In fact this value is probably strongly underestimated because swelling may occur at young age while the well graded aggregate has a low value of elastic modulus. In that case strains generate few compressive strength to counteract the effect of thermal shrinkage which occurs during the all life of the road when the elastic modulus is higher. Moreover part of the benefit of the swelling may be lost with time due to relaxation in the material.

As explained before, the theoretical estimation of the mixes swelling is based on the difference in packing density between a fresh mix and the same mix after weathering, calculated with René-LCPC

software. The calculation of these packing densities requires the preliminary following data for the different components:

- the grading curve;
- the specific gravity;
- the packing density.

For the BOF slag, these properties were determined before and after weathering. As the other components were assumed to be inert, their characterization was made only without weathering. The effect of weathering on the slag particles is assumed to be dependant on their size. So, for a better characterization of the slag before and after weathering, it was first separated by sieving it in five fractions. Each fraction was then characterized individually. For particles coarser than 80 $\mu$ m, the weathering procedure was carried out according to the procedure in EN 1744-1, paragraph 19.3, but a modification was brought to the classical procedure since samples were subjected to a very slight compaction with the vibrating table. The steam test equipment available at LCPC is described in figure C.2.1. Another weathering procedure was applied to the finest aggregate class. In fact, when submitting the 0/0.08 mm fraction to the steam test, we observed a sudden raising of the slag sample and covering surcharge, which exceeded the height of the cylinder. Consequently, we have chosen to weather this finest fraction by immersion in water at 110°C (chamber temperature) during five days.

The results are shown below.

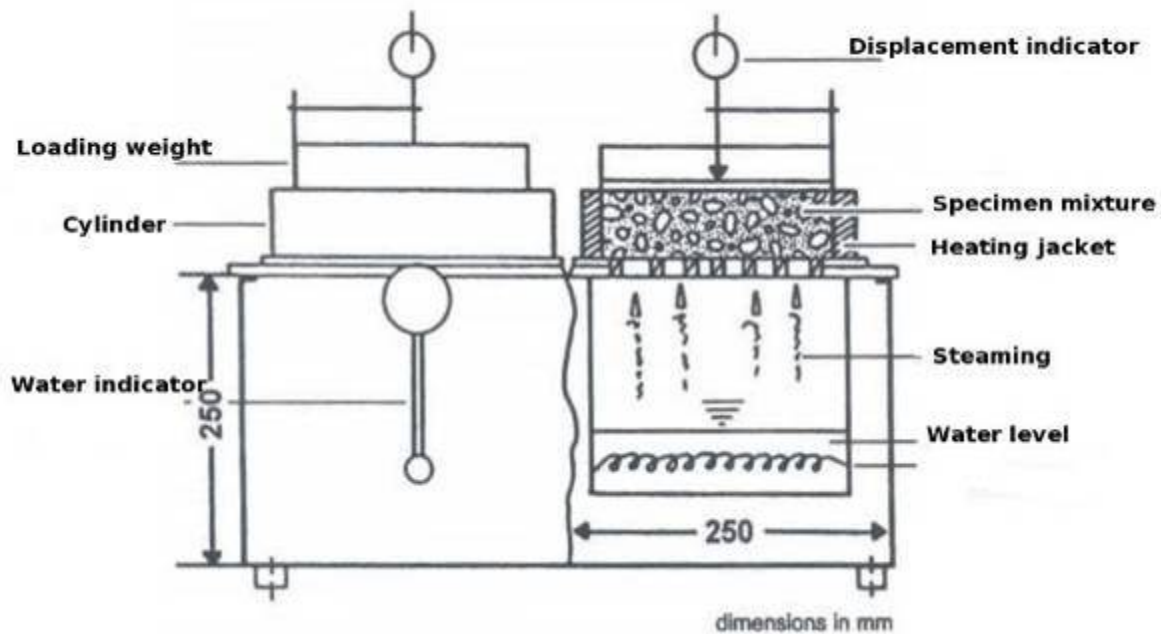

Figure C.2.1: Principle of the steam apparatus: the sample is submitted to a steam flow while its height is monitored versus time

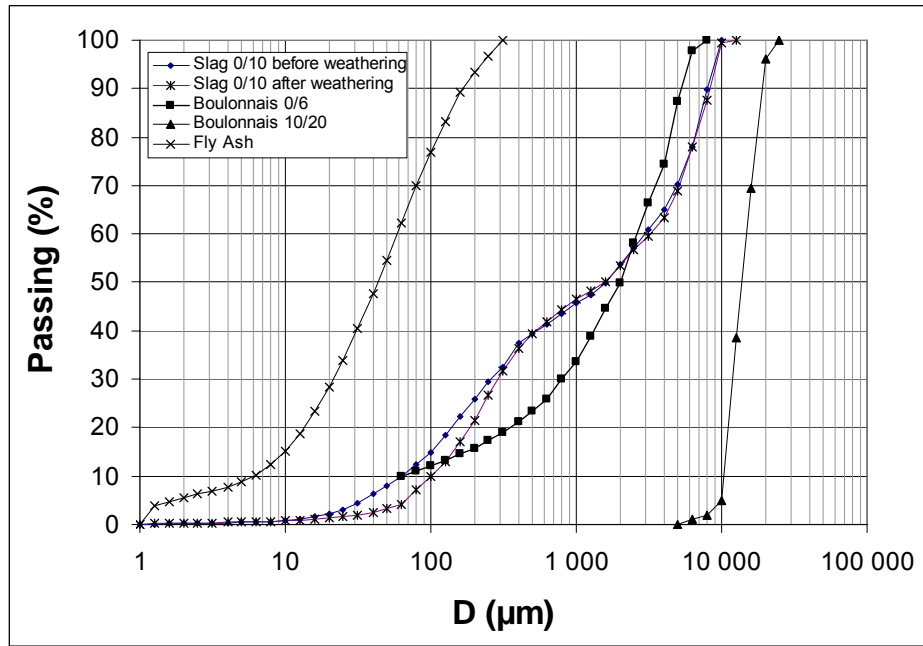

Figure C.2.2: Grading curves of the components

Material	Specific gravity (kg/l)		Packing densities	
	Without weathering	After weathering	Without weathering	After weathering
Slag fraction 0/80 $\mu$	2.75	2.88	0.46	0.43
Slag fraction 80 $\mu$ /315 $\mu$	2.76	2.88	0.444	0.392
Slag fraction 315 $\mu$ /2mm	2.96	2.99	0.482	0.446
Slag fraction 2mm/6.3mm	3.06	3.11	0.551	0.533
Slag fraction 6.3mm/10mm	3.09	3.14	0.568	0.548
Limestone 0/6.3 mm	2.64		0.628	
Limestone 10/20 mm	2.67		0.574	
Fly Ash	2.16		0.601	

Table C.2.1: Packing densities and specific gravity of the components

In conclusion, it can be observed that the weathering of slag mainly leads to:

- a decrease of the packing density (mean value -7%);
- almost no change in the specific gravity (mean value +2,5%);
- aggregation of small particles and splitting of coarse particles.

The measurements made on the BOF-slag have shown that they contain approximately a total of 10% of free lime and that only 50% of this lime can be hydrated. Moreover the European norm EN 14227-3 and the French one NF 98118 suggest for classical fly ash/lime well graded aggregate the following mean dosages:

- 10% of fly ash (between 8 to 12%)
- 1,7% of CaO (1,4 to 2,1) or 2,5% of Ca(OH)<sub>2</sub> (2 to 3%)

These data lead to select a ratio of CaO/FA=0.17 in our mixes. When possible the CaO will be brought by the BO-slag. Which means a ratio BOF slag/ FA= 3.4.

René-LCPC software was used to generate different preliminary recipes (see Table C.2.2) with different theoretical swelling. Note that these swelling are probably overestimated here as the model

was developed for packing without any hydraulic or pozzolanic reaction. In the present case, strength and so elastic modulus of the different mixes are expected to increase, thus restraining the swelling.

The assumptions of the calculations were the following:

- the packing index corresponding to the moulding of the sample is fixed 12. This value was fitted from the one obtained for packing at optimum proctor by Pouliot et al (2001).
- the calculations are made with no wall effect to be representative of free swelling of a huge sample of material.

In the first series (F1, F2, F3) we have:

- fixed the BOF-Slag/FA ratio to 3.4. By this way we have made the assumption that all the quick lime necessary for the fly ash was furnished by the slag;
- varied the BOF-Slag /limestone ratio to generate different swelling values. In a first time we have only selected the 10/20 limestone in order lessen the granular interaction with the slag particles. This theoretically allows moderate values of swelling even with high volume of slag ("the slag particles expand between the coarse inert particles with few effect on their packing arrangement).

In the second series (F1, F4, F5) we have:

- the same BOF-Slag /limestone as in the first series to keep almost the same swelling level;
- imposed a content of 10% of fly ash to aim at higher theoretical mechanical properties (before swelling). In that case the quick lime furnished by the slag is not sufficient and we have to add directly a pat of it to maintain the CaO/FA ratio constant.

Mix	Fly Ash (%)	Lime stone 10/20 (%)	Lime stone 0/6 (%)	Steel slag 0-10 (%)	Cao (%)	Ca0/CV	LD 0-10 (% except CV and Cao)	Initial theoretical porosity	Initial dry apparent density (kg/m <sup>3</sup> )	Theoretical swelling (%)
<b>F1</b>	10	56	0	34	0	0.17	37.8	0.1959	2162	2.63
<b>F2</b>	7	69.2	0	23.8	0	0.17	25.6	0.2455	2025	1.29
<b>F3</b>	4	82.4	0	13.6	0	0.17	14.2	0.3105	1846	0.60
<b>F1</b>	10	56	0	34	0	0.17	37.8	0.1959	2162	2.63
<b>F4</b>	10	66.4	0	23.1	0.5	0.17	25.8	0.2226	2070	1.30
<b>F5</b>	10	76.3	0	12.6	1.1	0.17	14.2	0.2634	1943	0.60

Table C.2.2: Theoretical swelling of different well graded aggregate calculated with Rene-LCPC software

Table C.2.3 shows the mechanical performance obtained. After casting the cylinders were slowly heated to 80°C during one day, then cured at 80°C for 5 days and finally slowly refresh to 20°C during one day. The cylinders were preserved from desiccation during curing.

Mix	Fly Ash (%)	Lime stone 10/20 (%)	Lime stone 0/6 (%)	Steel slag 0-10 (%)	CaO (%)	$\rho_{dopm}$ (t/m <sup>3</sup> )	$W_{opm}$ (%)	Packing density	Splitting tensile strength (Mpa)
F1	10	56	0	34	0	2.23	7.5	0.829	0.16
F2	7	69.2	0	23.8	0	2.13	5.5	0.792	0.16
F3	4	82.4	0	13.6	0	2.02	3.5	0.754	0.19
F4	10	66.4	0	23.1	0.5	2.2	6.8	0.824	0.35
F5	10	76.3	0	12.6	1.1	2.16	6.2	0.819	0.49

Table C.2.3: Mechanical properties of the mixes at the optimum proctor

The results show that only limited performances in splitting tensile strength are reached with the mixes in the first series, where no quick lime is added. This can be explained in F1 by important swelling. The graphic C.2.3 shows that at the end of curing, cracks have appeared in the cylinders as well as brown zones which are typical of CaO hydration in the slag aggregates. In F3, the low performance is probably due to the low content of fly ash. Moreover, in that series, it is possible that even if pozzolanic reactivity is accelerated by the increase of curing temperature on one hand, the diffusion of the quick lime liberated from the slag aggregate is not accelerated on the other hand. The consequence may then be that the fly ash particles are not in contact with lime and that pozzolanic reaction does not occur much in the first week.

In the second series, F5 reach 0,5 MPa in tensile strength. This result is encouraging as theoretical swelling is around  $6000 \cdot 10^{-6}$ . As it can be seen in figure C.2.4, no cracks was visible on the sample after curing.



Figure C.2.3: Pictures of the F1 mix after curing. Segregation is due to the gap graded skeleton. Cracks are visible as well as brown scaling due to quicklime hydration in slag particles



Figure C.2.4: Pictures of the F5 mix after curing. Segregation is due to the gap graded skeleton. No cracks are visible.

In a first approach, we intended to use the steam machine presented in figure C.2.1 to make the swelling measurements in accelerated conditions. This apparatus allows a steam curing at 100°C and was already equipped with a displacement indicator. Yet after several trials it appears that the steam was not able to go through the sample because of the low porosity of the samples and that the displacement observed were due to a piston effect and not to swelling. Then a new way of measuring the swelling was tested

Using the procedure classically used for concrete samples, the idea is to include two steel inserts on in the two faces of a Ø16x 32 cm. The distance between these two inserts will then be measured at different ages with the measurement device presented in the figure C.2.5



Figure C.2.5: Tool realized for length measurement of Ø16x 32 cm of well graded aggregate. The zero is made thanks an invar bar. The contact with the inserts of the sample or the bar are ensured by two steel balls.

Compared to concrete we have here two main difficulties:

- samples are compacted and not cast. A new device must be design to be included in the mould of the VCEC compacting machine, to be able to put the insert in the samples;
- measurements have to be started at a young age, when the well grade aggregate has almost no tensile strength. So the anchorage of the insert has to be well studied.

The graphic C.2.6 describes the system developed to include the inserts during compaction:

- a steel plate (9) is included in and empty millboard mould to which an insert (8) is screwed;
- the well-graded aggregate is included in the mould;
- another steel plate (7) with an insert is put on the material;
- the material is compacted with the piston (4).

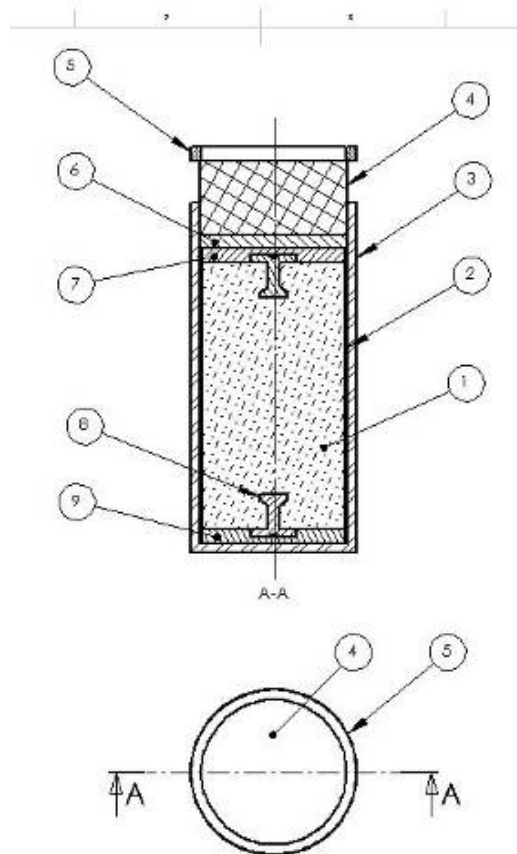

Figure C.2.6: Principle adopted to include the insert while compacting

After several tests, the insert shown in figure C.2.7 was selected. It is made of stainless steel with a conic form with flat parts. This geometry allows a good filling of granular material near the insert, avoids movement and rotation of the insert at early age. A preliminary test has shown this new version of inserts is well anchored and allows a stable evaluation of the sample length.



Figure C.2.7: Selected version of insert, with flat plates on the conic part, is well anchored

#### 10.5.4 CONCLUSIONS

On the basis of the bibliographical analysis we have selected a set of constituents which could be relevant to produce well-graded aggregates with a swelling behaviour and mechanical performances similar to that of cement treated well-graded aggregates. We also have described a method potentially useful to make the design of such mixes.

Preliminary tests were done in hot conditions (higher than 80°C) in order to accelerate the mechanical performance increase as well as swelling in order to verify the feasibility of the innovation proposed. Unfortunately we met technical difficulties to develop a reliable free swelling test adapted to such well graded aggregate mixes. A promising prototype has been designed and tested but it still needs improvements.

Promising results were obtained as far as mechanical performance were concerned but we were not able to quantify the swelling of the mixes though swelling of some samples was obvious (crack due to lime hydration were visible).

The feasibility of the proposed concept could then not be verified during this project and need more research.

#### REFERENCE

- [1] D. Deneele, F. de Larrard, E. Rayssac and J. Reynard, "Control of basic oxygen steel slag swelling by mixing with inert material", 4th European Slag Conference Oulu (Finland), 20-21 June, 2005, p 187-198
- [2] J. Piret, A. Lesgardeur and A. Delmarcelle, "Utilisation de la scorie LD en construction Routière", Rapport Final C.R.M., Commission des Communautés Européennes, Recherche Technique Acier, Rapport Final EUR 7631 FR, 30 pp, 1982.
- [3] N.F. Best, "Volumetric stability of weathered LD slags containing both free lime and periclase.", Commission of the European Communities, Technical Steel Research, Final Report EUR 10753, EN, 93 pp, 1987.
- [4] L.M. Juckes, "Investigation of the connection between test results found in the laboratory on volume stability and the values found in practice for LD slags." Commission of the European Communities, Technical Steel Research, Final Report EUR 13430 EN, 1991, 57 pp
- [5] A. Tikkaoski, K Kujla and M. Mäkikyro, "Geotechnical properties of Blast Furnace Slag and LD-Steel Slag Mixtures for road construction", 4th European Slag Conference Oulu (Finland), 20-21 June, 2005, p 83-98
- [6] T. Sedran and F. De Larrard, "RENÉ-LCPC", freeware (in French) to be download on [www.lcpc.fr](http://www.lcpc.fr), 1995
- [7] F. De Larrard, "Concrete Mixture-Proportioning: a scientific approach", Modern Concrete Technology series No. 9, A. Bentur and S. Mindness editors, E & FN SPON, 1999
- [8] T. Sedran and F. De Larrard, "RENÉ-LCPC: a software to optimize the mix-design of High-Performance Concrete", BHP 96, 4th International Symposium on the Utilization of High-Strength/High-Performance Concrete, edited by F. de Larrard and R. Lacroix, Paris, May, 1996, pp. 169-178
- [9] T. Sedran, "Rhéologie et rhéométrie des bétons. Application aux bétons autonivelants", Thèse de l'ENPC, in french, March, 1999, 220 p
- [10] F. de Larrard, V. Ledee, T. Sedran, F. Brochu and J-B. Ducassou, "Nouvel essai de mesure de compacité des fractions granulaires à la table à chocs", Bulletin des Ponts et Chaussées, n° 246-247, sept-décembre, 2003, pp 101-115
- [11] V. Ledee, F. De Larrard, T. Sedran, F. Brochu, "Essai de compacité des fractions granulaires à la table à secousses : Mode opératoire", Méthode d'essai LPC N° 61 (laboratoire central des ponts et chaussées), Juillet, 2004.
- [12] N. Pouliot., T. Sedran, F. De Larrard, J. Marchand, "Formulation des bétons compactés au rouleau à l'aide d'un modèle d'empilement granulaire", Bulletin des laboratoires des Ponts et Chaussées, N° 233, Juillet-Août, 2001, pp. 23-36

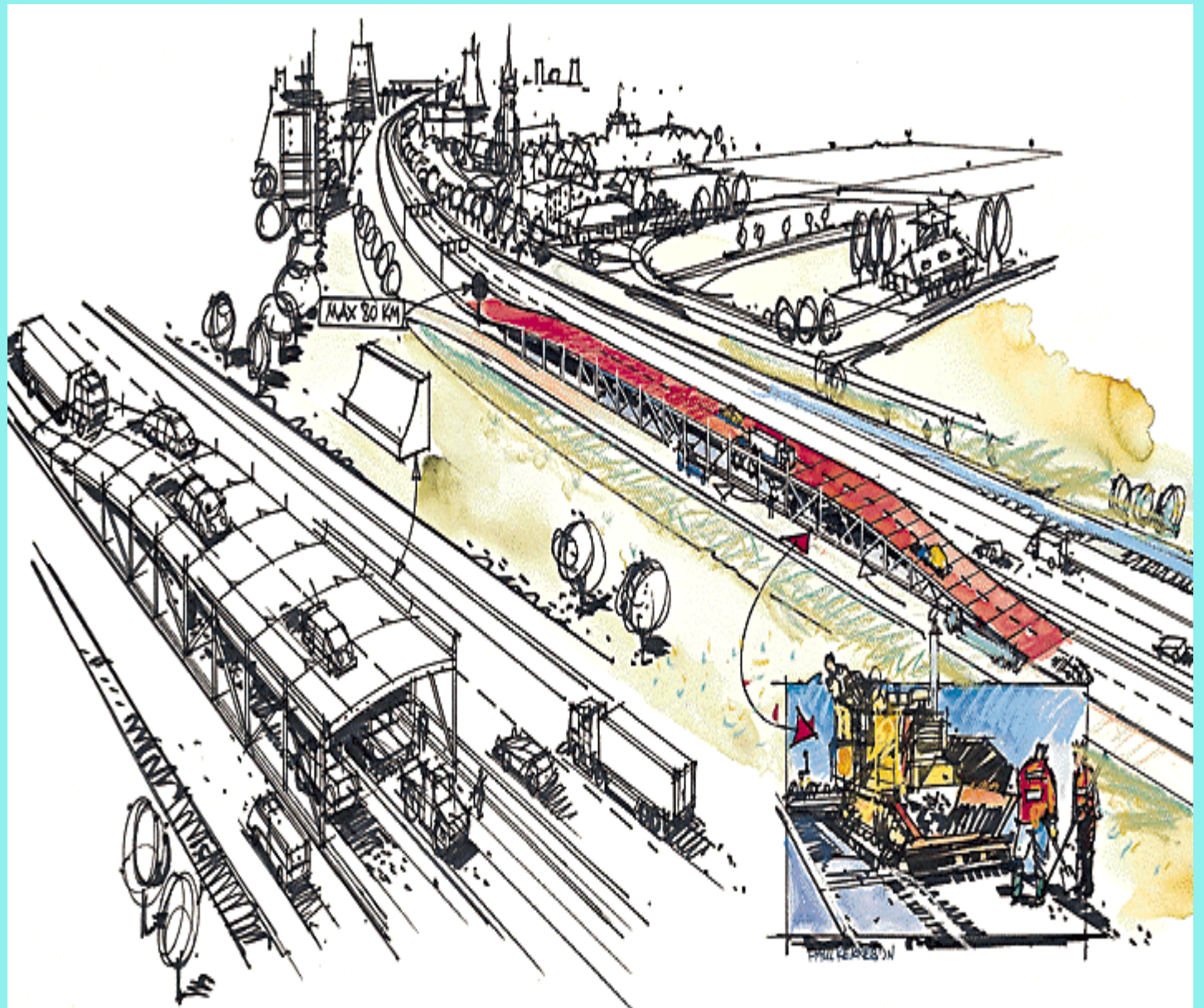



# 11 | Towards reliable infrastructure

## ROAD MAINTENANCE

### ***11.1 New pavement maintenance technique aiming at enlarging the overall conditions of application***

Jean-Pierre MARCHAND (EUROVIA – France)

#### **Summary**

This innovation consists in the development of new maintenance techniques and procedures aiming at expanding the overall conditions of application of mixtures for pavements. The benefit of such an innovation is to reduce the impact of the weather conditions on the quality of placing of pavement mixtures, and consequently on the mechanical properties and behaviour of the road structure. Another benefit is the reduction of the impact of road closure due to maintenance on the road users, as it would be more likely to carry out pavement maintenance at more opportune times or periods throughout the year.

#### **11.1.1 ORGANISATION AND TASKS**

The first step in this research is to identify the climatic parameters which have an incidence on the pavement maintenance works, on the quality of the mixtures that are placed and finally on the behaviour of pavement. Some of these climatic parameters lead to a reduction of the mechanical properties of the material and consequently on the pavement performance. So it will be necessary to identify the linkage between the climatic factors and the mechanical properties of the layers after placing. In terms of product it will be necessary to distinguish the components (bitumen, hydraulic binder...) and the final product (layer).

The main goal is to formulate some “realistic” proposals considering the requirements and the specifications of the innovation and the foreseen advantages and to produce a guide providing information aiming at reducing the effects of the weather conditions on the maintenance works, and consequently the risk of having poor pavement mechanical properties leading to a poor behaviour of the road structure.

#### **11.1.2 RATING TREE**

##### **Climatic factors and materials**

In order to implement this rating tree it has been necessary to identify the climatic parameters, which do not allow the continuation of the job sites. For this task we have used the specifications in the contracts.

These parameters are the following:

**Wind Cold rain Snow Storm Night**

It has been necessary to add **Heat and Heat and Loading**. These factors are not yet considered as negative parameters on job sites, but the high temperatures in 2006 summer oblige us to integrate them.

Note: During the bibliography research it has not been easy to find some information about the weather conditions (or weather restrictions) in official guidelines for the road industry.

After this identification, due to **different processes of manufacturing** it was necessary to **distinguish bituminous** (it is necessary to heat and dry the aggregates in order to get the same temperature as thus of the bitumen which is added) and **hydraulic** (aggregates are used at ambient temperature and water is added for the setting of the binder and sometimes in order to improve the workability during the mix phases) **bounded materials**. The manufacturing of these materials are different.

### 11.1.3 INFLUENCES OF CLIMATIC PARAMETERS

The most original part of this work is the identification of the relationship between the climatic parameters and the properties of the materials.

The properties of the materials can be shared in two classes:

#### **Mechanical properties**

- They are linked with the behaviour of the materials and the life duration of the pavement. The most well-known criteria are the stiffness (characterized by the elastic modulus) and the fatigue behaviour (characterized by the allowed strain at  $10^6$  cycles ).
- One of the two most important criteria are the increasing voids content due to a lack of workability of the mix and the presence of cracks (longitudinal or transversal).

#### **Safety properties**

- They are linked with surface characteristics of the road. We find evenness, lack of skid resistance, risk of rutting.
- And the risk of accident when there are fumes due to the contact of moisture (or rain) with hot asphalt mixes.

### 11.1.4 RATING TREE FOR BITUMINOUS MATERIALS

During this phases different rating trees have been elaborated taking into account the different climatic parameters mentioned in § 1.2.1.

For example only three of them : cold, rain and heat are described in this summary because they are the most important and frequent on the job site

## Cold

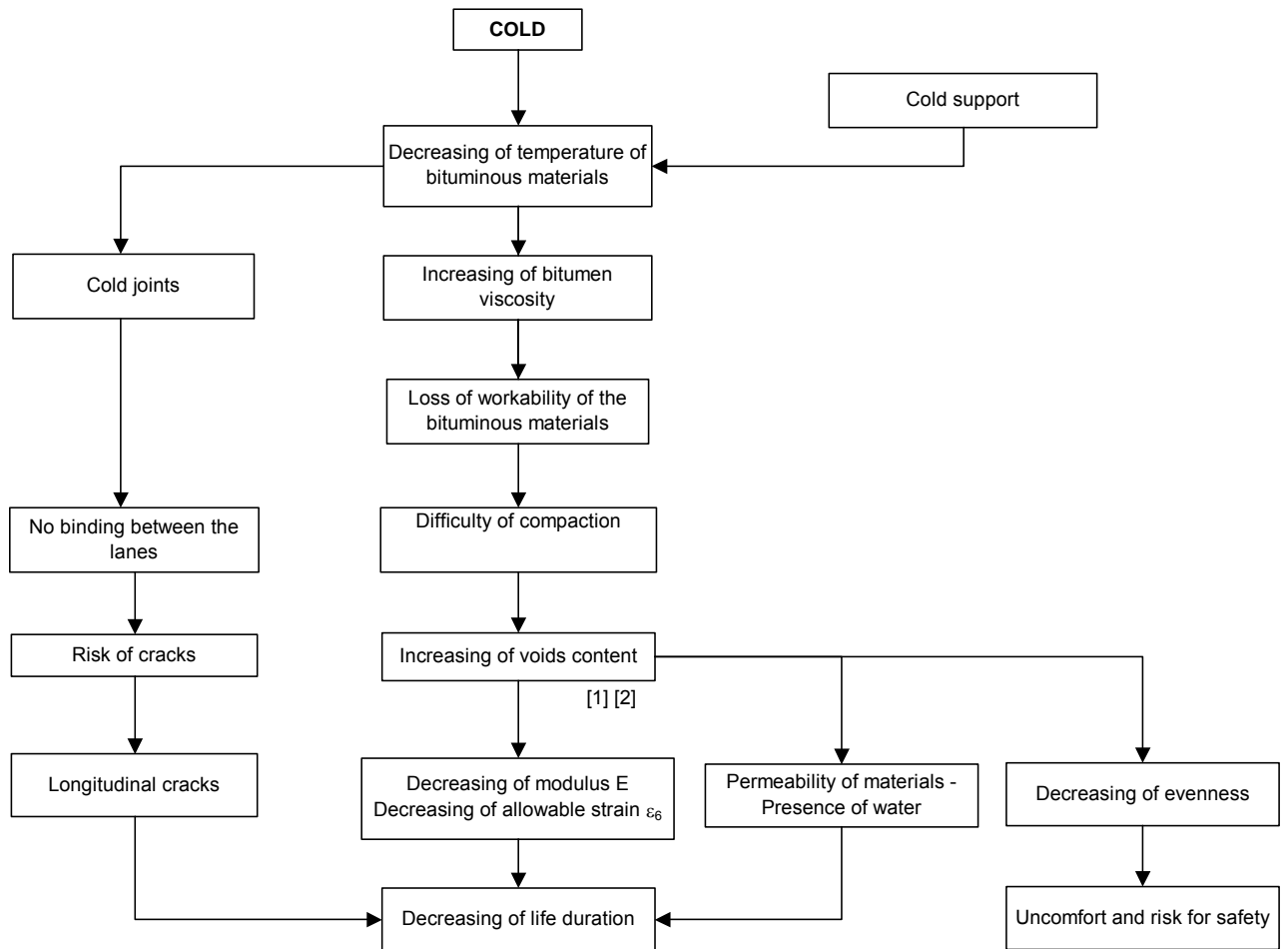

## Rain

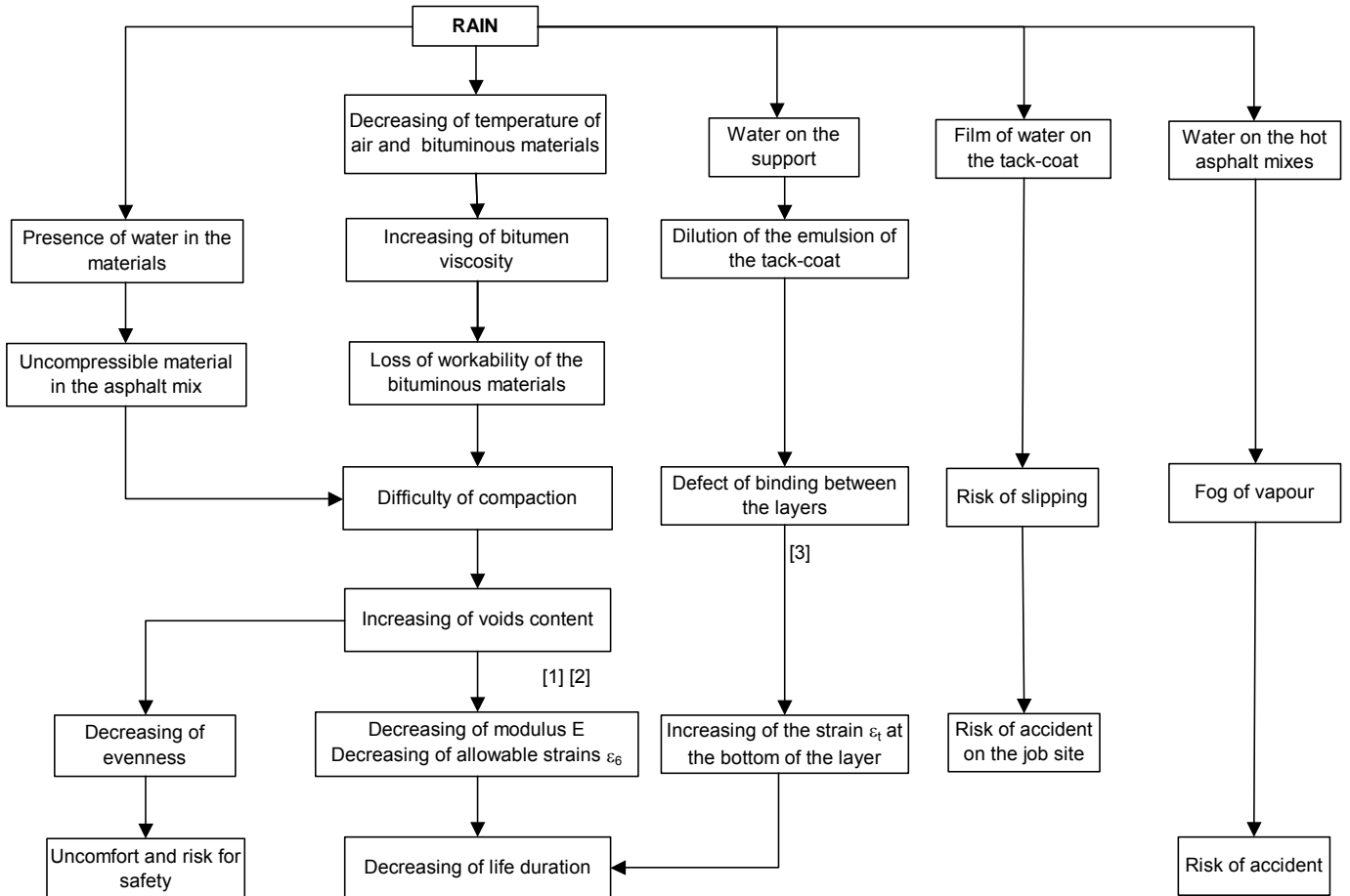

## heat before loading

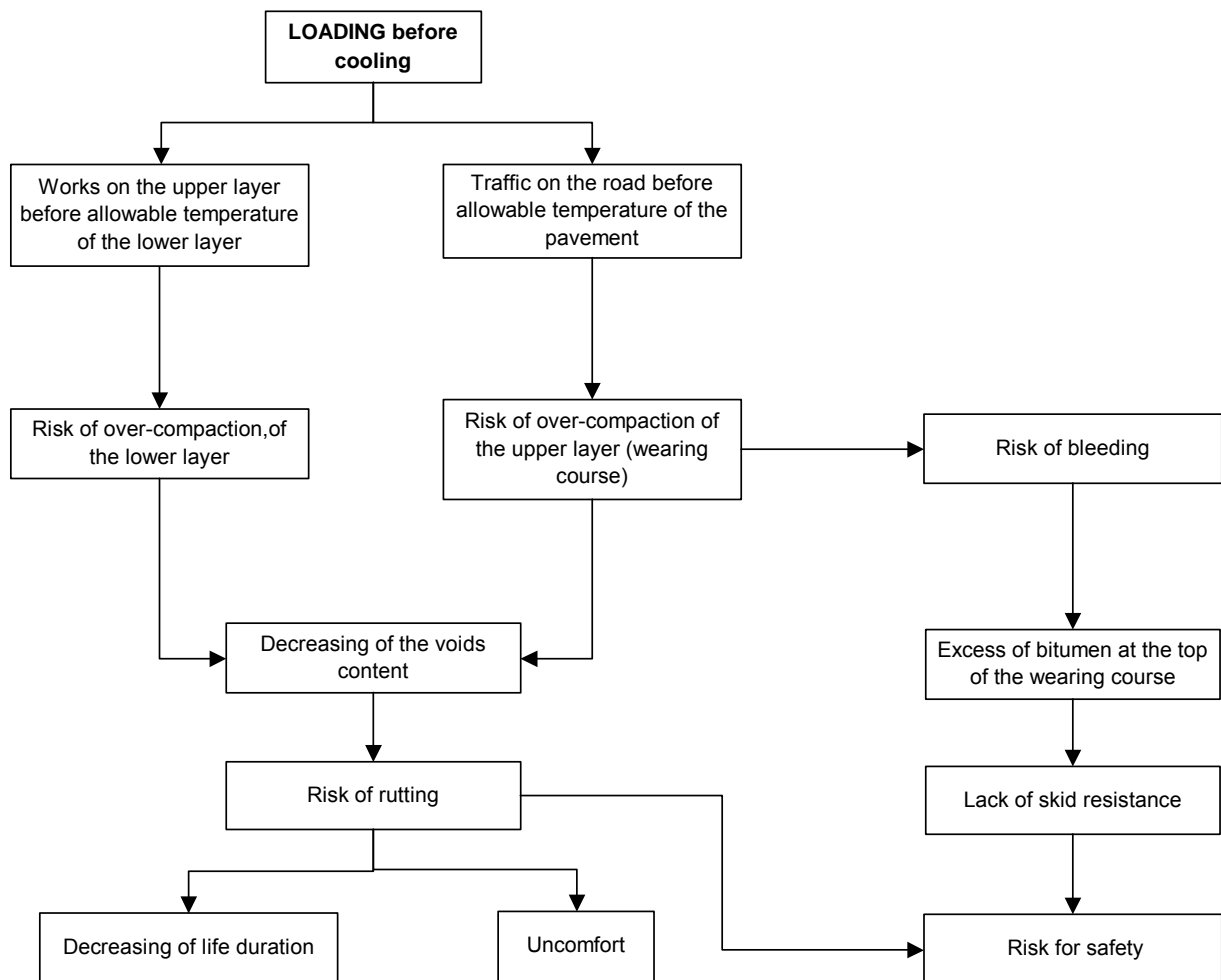

### 11.1.5 RATING TREE FOR HYDRAULIC BOUNDED MATERIALS

For this type of materials it was easy summarize on a single rating tree the influence of climatic parameters.

#### Cold, rain and heat

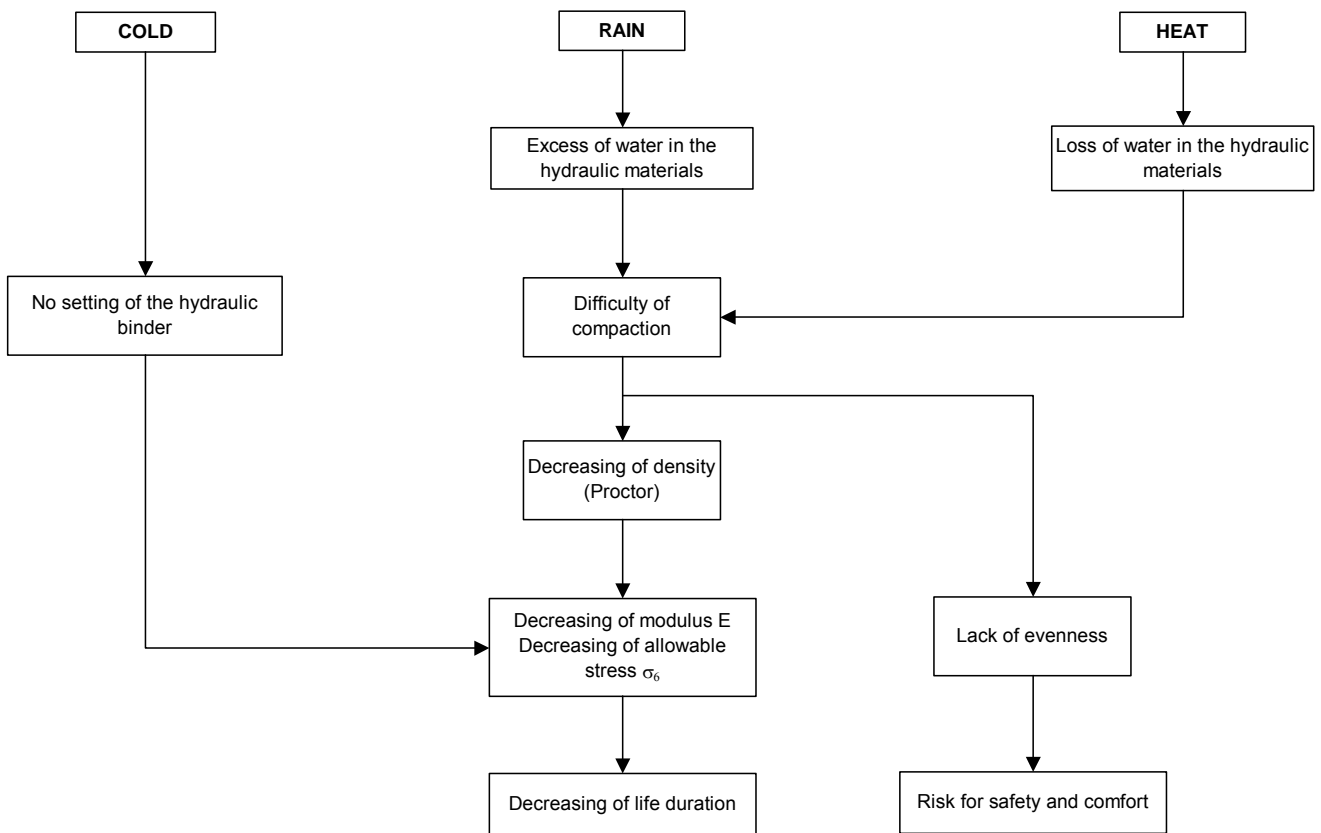

### 11.1.6 SOLUTIONS FOR BITUMINOUS MATERIALS

#### Cold

When the outside temperature is lower than these allowed in the specification (or know by the state of the art) the bitumen viscosity increase. To solve this problem one way is to maintain the workability of asphalt mix by adding wax or zeolite.

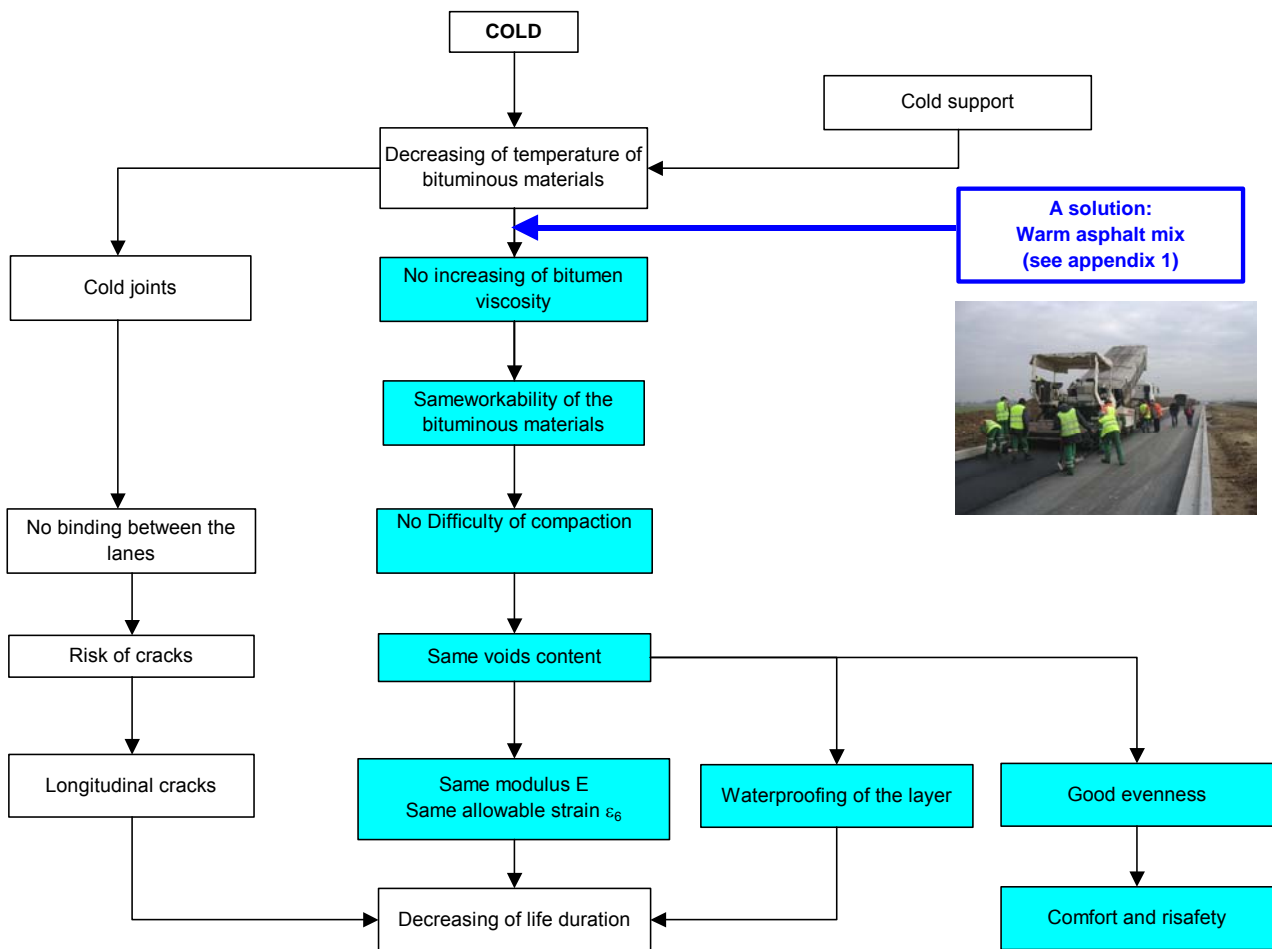

An other consequence of the cold is the lack of binding between two widths of mix. A solution can be found with a preformed adhesive strip used on a job site in 2005..

## Rain

When it is raining, the rain cools the asphalt mix (see above) and there is a production of foam or vapour. This is due to the large range of temperature between the asphalt mix (160 to 170°C) and thus of the rain (10 to 15°C). To solve this problem one way is to reduce the temperature of the asphalt mix by adding wax or zeolite

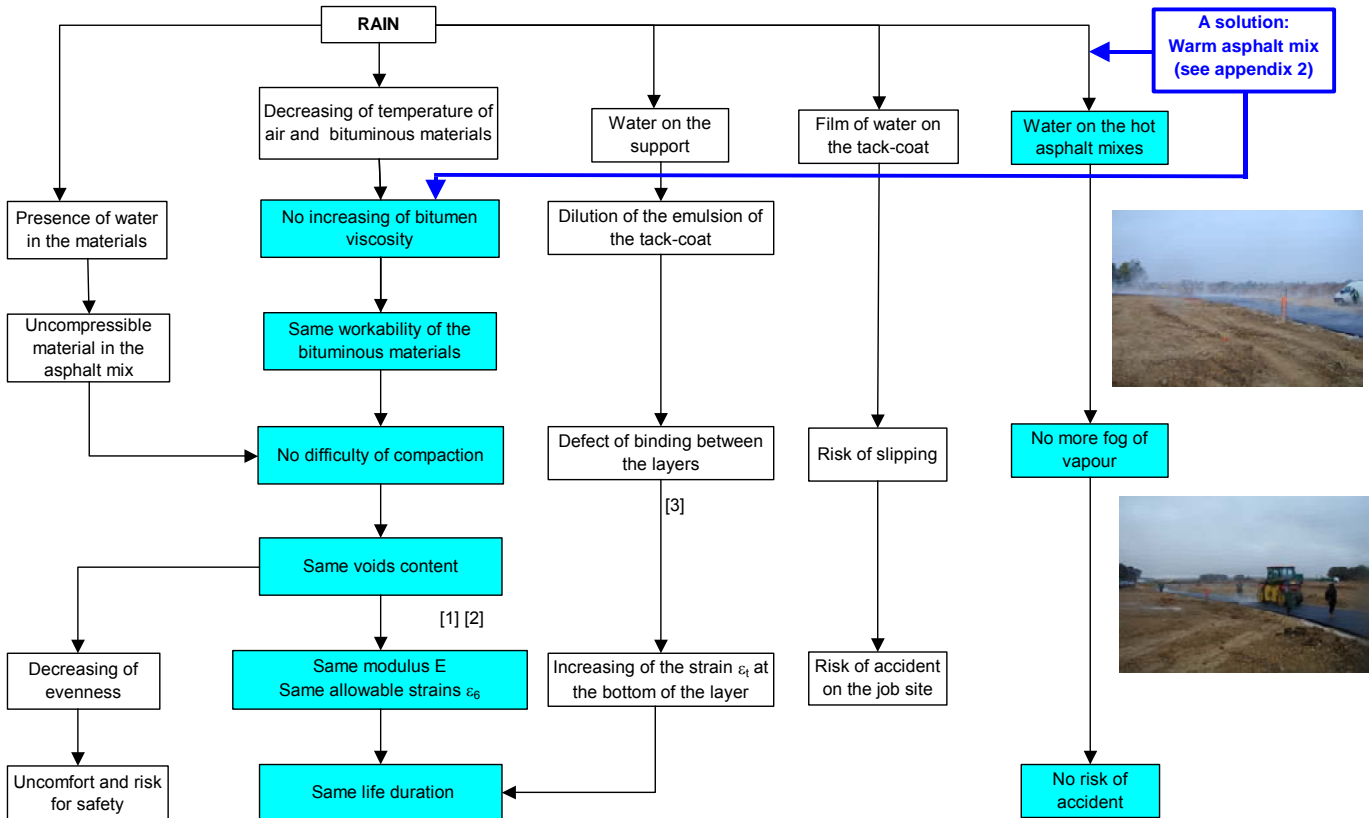

## Loading before cooling

When asphalt mix is always hot, its mechanical performances are low. Its modulus (depending of temperature) is decreasing.

The time necessary to reach the optimal temperature (60°C) may be long. By reducing the asphalt temperature during the manufacturing, it is possible to gain faster the optimal characteristics and avoid early rutting.

Reference documents are documents which fall in the following two categories:  
 either they are explicitly mentioned in the text of the Project Quality Plan;  
 or they do not contain binding requirements.

## 11.1.7 CONCLUSIONS

### Bituminous bounding materials

The solutions provided for enlarging the overall conditions of application have been founded only for the following climatic parameters:

#### **Cold, Rain, Wind Heat and loading**

Some consequences of climatic parameters such as water on support, film of water on tack-coat have not been solved with original solutions.

In the case of storm or snow the best way is to wait... better weather conditions.

### Hydraulic bounding materials

No original solutions have been provided for enlarging the overall conditions of application due to the fact that there is no means to smooth influence of cold, rain or wind.

### Trends

The opportunity of enlarging the overall condition of pavement materials application is not an authorization for working when the risk of failure or damage is too high. It is only a controlled opportunity.

## REFERENCES

- [1] Soliman et Doan - Influence des paramètres de formulation sur le module et la résistance à la fatigue des graves-bitume – Bull. liaison des P. et Ch. Spécial V, décembre 1977, PP 229-245
- [2] Setra - Lcpc - Conception et dimensionnement des structures de chaussée, Guide technique, décembre 1994, p. V 5.3.1
- [3] B. Eckmann « Un logiciel de calcul pour la mécanique des chaussées » - RGRA n°639, 1987, p 50
- [4] Setra - Lcpc - Conception et dimensionnement des structures de chaussée, Guide technique, décembre 1994, p. V 5.3.1
- [5] Pavcool program : Minnessota Department of Transportation  
[http://www.mrr.dot.state.mn.us/research/MnROAD\\_Project/restools/cooltool.asp](http://www.mrr.dot.state.mn.us/research/MnROAD_Project/restools/cooltool.asp)
- [6] NCAT : Evaluation of aspha-min<sup>®</sup> zeolite for use in warm mix asphalt, NCAT, Report 05-04, June 2005
- [7] NCAT : Evaluation of aspha-min Sasobit<sup>®</sup> for use in warm mix asphalt, NCAT, Report 05-06, June 2005
- [8] Eurovia : Treating mix joints with a preformed adhesive strip, Technoroute 286, September 2005

## 11.2 Hybrid FRP-concrete sandwich structure with lightweight concrete core for bridge decks

Erika SCHAUMANN (Ecole Polytechnique Fédérale de Lausanne (EPFL) – Composite Construction Laboratory (CCLab) – Switzerland)  
 Thomas KELLER (EPFL –CCLab – Switzerland)

### Summary

This report presents a new concept for a lightweight hybrid-FRP bridge deck. The sandwich construction consists of three layers: a glass fiber-reinforced polymer composite (GFRP) sheet with T-upstands for the tensile skin, lightweight concrete (LC) for the core and a thin layer of ultra-high performance fiber-reinforced concrete (UHPFRC) as a compression skin. Mechanical tests on long- and short-span hybrid beams were performed using two types of LC with different fracture mechanics properties and two types of FRP-LC interface: unbonded (only mechanical interlocking of LC between T-upstands) and bonded with an epoxy adhesive. The experiments showed that ultimate load is determined by the shear strength of the LC core. A fracture mechanics-based shear strength prediction method was therefore developed. The experimental results and modeling highlighted the importance of considering not only static strength, but also fracture mechanics properties such as the LC characteristic length. Moreover, a design concept was developed demonstrating the feasibility of the suggested hybrid bridge deck and allowing the definition of the required LC material properties according to the transverse bridge span.

### 11.2.1 INTRODUCTION

Within the framework of the NR2C WP3 working group, a novel concept for a lightweight hybrid sandwich bridge deck system, combining fiber-reinforced polymer (FRP) composites with concrete, was proposed. The system comprises three layers of different materials: FRP composites for the tension skin, lightweight concrete (LC) as a core material and ultra-high performance fiber-reinforced concrete (UHPFRC) for the compression skin (see Figs. 1-3). The use of LC should enable a total deck weight of less than 50% of that of a normal concrete deck to be achieved. The FRP sheet with T-upstands serves as formwork, while the T-upstands should provide composite action through a mechanical interlocking between the basic FRP sheet and the LC core. The fibers in the UHPFRC layer are required to bear any local bending moments caused by concentrated wheel loads. The shear forces in the deck are transferred by the LC and not by the FRP webs, which are sensitive to buckling. No additional shear reinforcements are used in order to provide a simple and cost-effective manufacturing process for the slab.

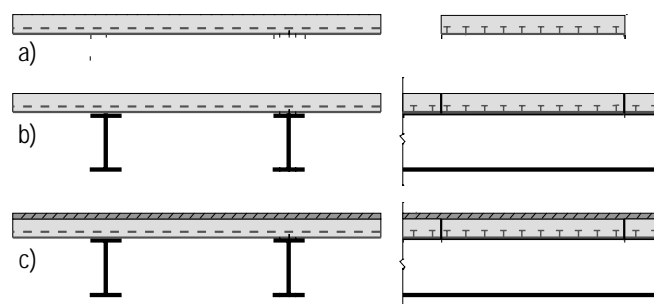

Figure 1 - Composition, manufacturing and installation of hybrid bridge deck, a) prefabricated FRP-LC panels, b) FRP-LC panels bonded together and onto girders, c) jointless UHPFRC casting

The FRP layer combined with the LC core is easily prefabricated in large elements that are transported to the site and rapidly installed on the main girders. The joints between the deck elements and between deck and main girders are adhesively bonded. Subsequently, the thin UHPFRC layer is jointlessly cast onto the LC core on site. In regions of negative bending moments, FRP reinforcement grids are incorporated into the UHPFRC layer. Since the deck is steel-free and the UHPFRC layer watertight, no waterproofing layer is required and the surfacing is directly applied onto the UHPFRC.

To examine the feasibility of the proposed slab concept, the shear load-bearing behavior of hybrid FRP-concrete sandwich beams with exhibiting different FRP-LC interfaces and shear span-to-depth ratios of  $a/d = 8.0$  and  $1.6$  was experimentally investigated. Two different types of LC materials were used for the core: sand-lightweight aggregate concrete (SLWAC) and all lightweight aggregate concrete (ALWAC). A fracture mechanics-based shear strength prediction method was developed and validated through the experiments. Moreover, a design concept for the hybrid bridge deck was presented and discussed in function of different transverse bridge spans. This paper summarizes the main results and conclusions drawn from the experiments, modeling and design examples.

## 11.2.2 EXPERIMENTS

### Beam description

The experimental program consisted of twelve 3600-mm long-span and eight 1200-mm short-span beam specimens, 400-mm wide and 200-mm deep and is described in detail in D3.4. A structural system less complex than a plate was chosen to better separate and understand the basic load-bearing mechanisms. The top skin was a 30-mm normal concrete (NC) layer, since beam design showed that it was not necessary to use UHPFRC for the experiments. For the bottom FRP skin, standard GFRP pultruded Plank 40HDx500 elements from Fiberline were used. For the sandwich core, three different LCs were used: two SLWAC mixtures and one ALWAC mixture. Furthermore, two types of FRP-LC interfaces were investigated: pure mechanical interlocking between FRP T-upstands and the LC core, and bonding of the FRP-LC interface using an epoxy adhesive. In the case of the two long-span ALWAC beams, the total beam depth over the supports was cast with NC (anchor blocks with epoxy-bonded FRP-NC interface) to prevent FRP-LC slippage over the supports. Table 1 gives an overview of all investigated specimen configurations and their labeling, while Figs. 2 – 3 illustrate the beam dimensions.

Beam labeling	LC Type	LC density [kg/m <sup>3</sup> ]*	FRP-LC interface	NC anchor blocks	a/d ratio
900-1/2	SLWAC	900	unbonded	no	8.0
900E-1/2	SLWAC	900	bonded	no	8.0
1300-1/2	SLWAC	1300	unbonded	no	8.0
1300E-1/2	SLWAC	1300	bonded	no	8.0
1000	ALWAC	1000	unbonded	no	8.0
1000E	ALWAC	1000	bonded	no	8.0
1000A	ALWAC	1000	unbonded	yes	8.0
1000EA	ALWAC	1000	bonded	yes	8.0
900Es-1/2	SLWAC	900	bonded	no	1.6
1300s-1/2	SLWAC	1300	unbonded	no	1.6
1300Es-1/2	SLWAC	1300	bonded	no	1.6
1000s	ALWAC	1000	unbonded	no	1.6
1000Es	ALWAC	1000	bonded	no	1.6

Table 1 Experimental configurations (\*rounded values)

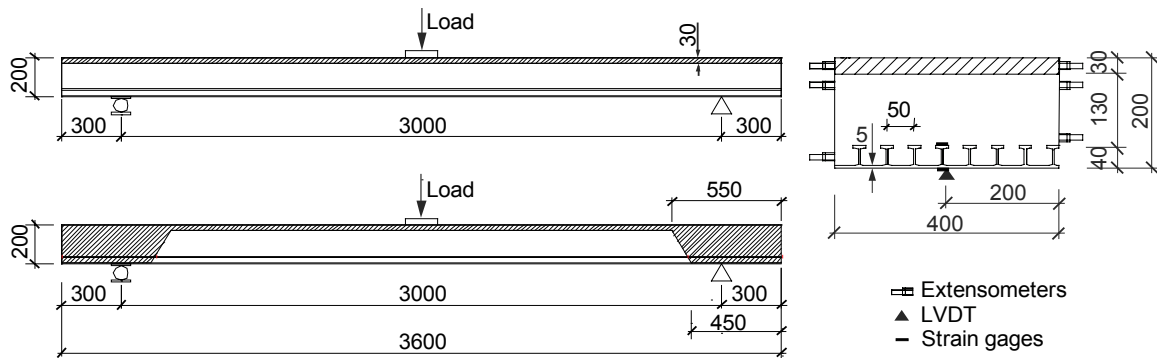

Figure 2 Experimental setup and configurations of long-span beams without (above) and with (below) NC anchor blocks over supports

### Material properties

The GFRP Plank elements exhibited a tensile strength of 240 MPa and a Young's Modulus of 23 GPa (Fiberline 2006). The epoxy adhesive used for the FRP-LC interface was SikaDur 330 from Sika, with an axial tensile strength of 38 MPa. For the NC-layer, a standard mixture of self-compacting concrete was used, with an average compressive strength of 51.2 MPa and a Young's Modulus of 29.7 GPa.

The SLWAC mixtures LC900 and LC1300 consisted of expanded clay aggregates (Liapor F3), normal sand, cement and water. The ALWAC LC1000 was composed of the same expanded clay aggregates (Liapor F3) and expanded glass aggregates (Liaver), both supplied by Liapor (Switzerland), cement, filler, adjuvants, and water. Mean compressive strengths,  $f_{lc,m}$ , and Young's Moduli,  $E_{lc,m}$ , as well as mean splitting tensile strengths,  $f_{lctsp,m}$ , were determined on cylinders. The LC densities were also measured using the cylinders, after storage in a climate room at 20°C and 95% humidity for 28 days. According to Faust (2002), the characteristic lengths,  $l_{ch}$ , can be estimated as being approximately 150 mm for the SLWAC compositions, while 40 mm can be assumed for the ALWAC mixture. The characteristic length is an indicator of concrete brittleness and represents the length of a tie in which the required elastic energy to create a transverse fracture surface is stored. The LC material properties are summarized in Table 2 (average values and standard deviations).

Lightweight concrete	Density $\rho$ [kg/m <sup>3</sup> ]	Compr. strength $f_{lc,m}$ [MPa]	Young's modulus $E_{lc,m}$ [GPa]	Splitting tensile strength, $f_{lctsp,m}$ [MPa]
LC900 (SLWAC)	882 ± 10	2.1 ± 0.7	3.5 ± 0.2	0.65 ± 0.1
LC1000 (ALWAC)	997 ± 7	9.7 ± 1.4	6.4 ± 0.4	1.34 ± 0.14
LC1300 (SLWAC)	1294 ± 70	5.6 ± 1.2	8.7 ± 1.0	1.30 ± 0.2

Table 2 Material properties of lightweight concretes

### Experimental setup and instrumentation

The experimental setup for the long-span and short-span beams is shown in Figs 2–3. All beams were simply supported on rollers with a span length of 3000 mm (long-span) and 600 mm (short-span) and subjected to three-point bending. For all beams, linear voltage displacement transducers (LVDTs) were used to measure beam deflection along the span and the slippage of the LC and NC from the FRP element at the beam ends. For the long-span beams, strain gages were placed on the top and bottom faces of the FRP to measure FRP elongation, while omega-shaped extensometers enabled LC and NC deformations at mid-span through the beam depth to be measured as indicated in Figure 2. In the case of the short-span beams, omega-shaped extensometers enabled deformations on the concrete surface and on the bottom FRP profile to be measured as indicated in Figure 3.

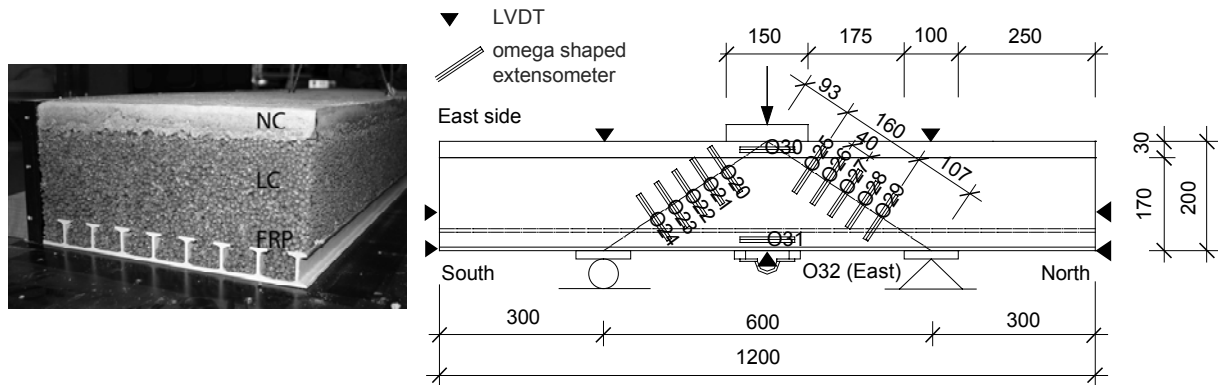

Figure 3 Beam cross section and beam dimensions, experimental setup and instrumentation for short-span beams

### Experimental investigations of long-span beams

#### Results

##### Unbonded beams

The load-deflection curves at mid-span measured for the unbonded beams without anchor blocks (900-1/2, 1300-1/2, 1000) are shown in Figure 4 (left). The ultimate loads,  $F_u$ , of the five unbonded beams and corresponding mid-span deflections are listed in Table 3. All beams showed an almost linear-elastic response up to 6.8-11 kN when the first small vertical cracks appeared in the tension zone of the LC below the loading plate (cracking load  $F_{cr}$ , see Table 3). The cracks always propagated through the LC aggregates. The 900-1/2 beams then totally lost their stiffness, whereas the load of beams 1300-1/2 could be increased up to an ultimate load of 32.1/23.3 kN. However, the stiffness decreased steadily and the LC started to debond from the FRP sheet at the beam ends (at 19 kN on average), as shown in Figure 4 (right) for beam 1300-2. In the case of the unbonded ALWAC beam 1000 only a slight loss of stiffness occurred, which then remained almost constant until the ultimate load of 35.0 kN. Only from this load on could slippage in the FRP-LC interface be measured. A typical failure pattern of the unbonded beams is illustrated in Figure 5 for beam 1300-1.

Beam	$F_u$ [kN]	$F_{cr}$ [kN]	Mid-span deflection [mm]
900-1/2	9.3 / 11.3	6.5 / 7.5	11.5 / 9.4
900E-1/2	31.2 / 30.4	10.5 / 11.5	8.7 / 8.1
1000/1000E	35.0 / 39.2	9.0 / 8.0	11.5 / 9.9
1000A/1000EA	37.8 / 37.2	5.0 / 5.0	11.4 / 10.6
1300-1/-2	32.1 / 23.3	9.5 / 10.0	47.8 / 40.4
1300E-1/-2	42.8 / 50.5	13.0 / 12.5	12.3 / 14.1

Table 3 Summary of main results, LC properties and ultimate loads of all investigated beams

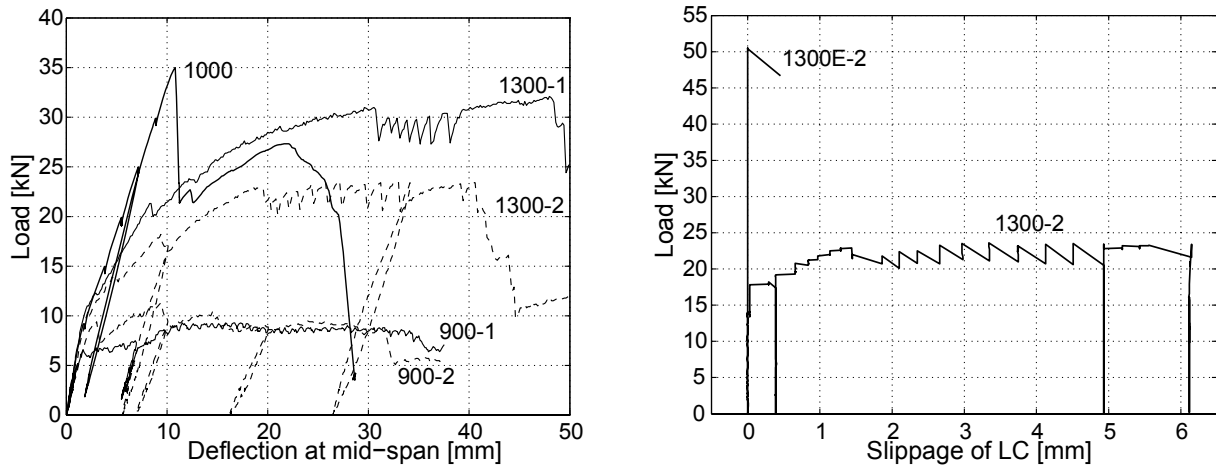

Figure 4 Load-deflection response of unbonded beams and slippage of LC from FRP sheet at beam ends (SLWAC beams 1300-2 and 1300E-2)



Figure 5 Failure pattern of unbonded SLWAC beam 1300-1 and slippage of LC from FRP sheet

#### Bonded beams and beams with anchor blocks

The representative load-deflection curves at mid-span measured for the bonded beams are shown in Figure 6 (left) while the cracking and ultimate loads of the anchored and bonded beams and mid-span deflections at failure are listed in Table 3. The responses of all beams showed a steady but slight decrease in stiffness up to ultimate failure. Both anchored beams exhibited a similar response to that of 1000E. A linear axial strain distribution through the depth of the beam at 25%, 50%, 75% and 100% of the ultimate load is shown in Figure 6 (right) and indicates full composite action between the FRP and concrete until the ultimate load. For all beams at ultimate load, one flexural crack suddenly propagated through the depth of the beam and along the LC-NC interface to the loading plate and along the top of the FRP T-upstands, just above the FRP-LC interface, over the support up to the end of the beam, as shown in Figure 7. The epoxy-bonded interfaces remained undamaged and no slippage was measured at the beam end, see Figure 4 (right) for 1300E-2.

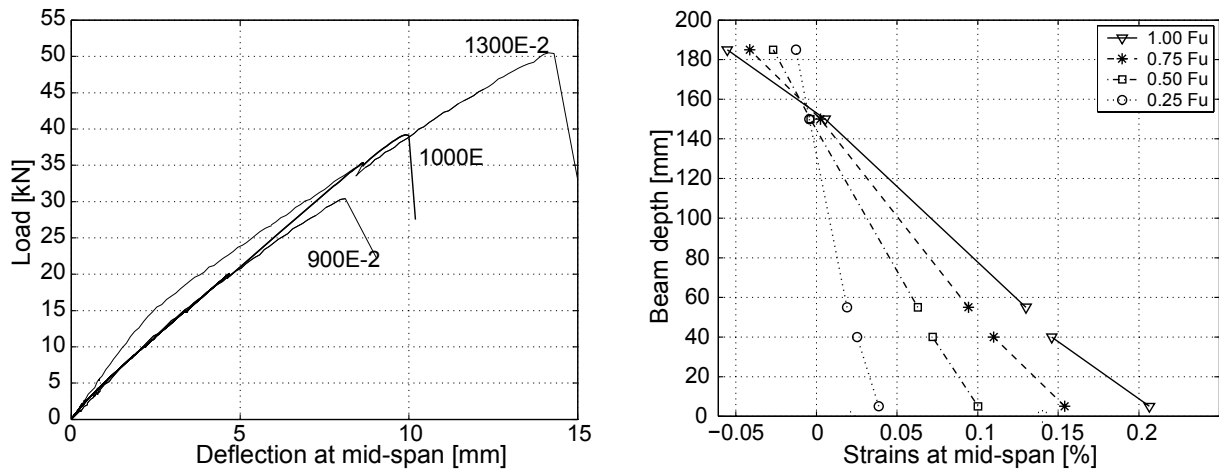

Figure 6 Load-deflection response of selected bonded beams and mid-span strain distributions through depth of bonded SLWAC beam 1300E-2

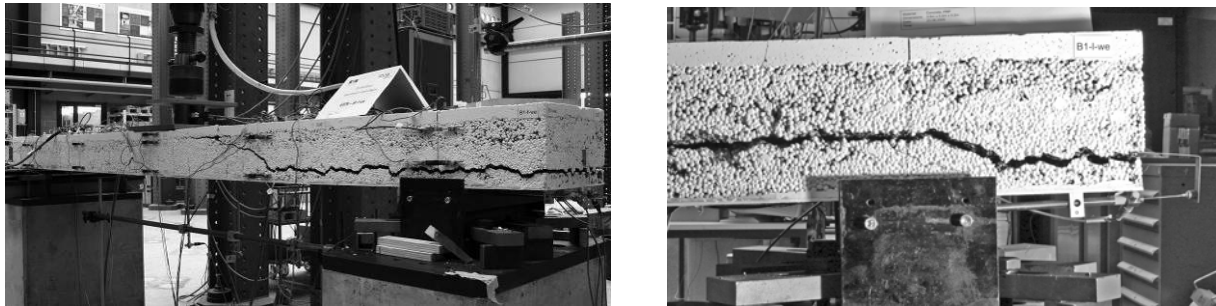

Figure 7 Failure pattern of whole bonded SLWAC beam 1300E-2 (left) and of beam 1300E-1 at support (right)

#### Discussion

In all investigated beams, shear failure occurred in the LC in one part of the beam. Failure in the unbonded ALWAC occurred suddenly followed by debonding of the FRP-LC interface, while a slow and ductile failure occurred in the unbonded SLWAC beams. The LC was thereby constantly pushed out at the beam end, while the main crack progressed slowly along the FRP-LC interface and stopped at the support. The main crack in the bonded beams, however, progressed rapidly over the support to the beam end, always propagating through the LC aggregates. The LC shear strength was therefore smaller than the bonded interface shear strength. The crack stopped at the LC-NC interface of the anchor blocks in these beams.

All bonded SLWAC and all ALWAC beams exhibited full composite action up to brittle shear failure in the LC core. In the case of the unbonded ALWAC beam 1000, the mechanical interlocking between the LC and FRP sheet was strong enough to provide full composite action up to a sudden shear failure in the LC core. For the unbonded SLWAC beams in contrast, debonding in the interface occurred at lower loads and accordingly, the deflections increased considerably up to ultimate failure. The improvement for the unbonded ALWAC beams was ascribed to the superior mechanical behavior of LC1000 compared to the SLWAC LCs. The much higher compressive strength of the former (see Table 2) increased the friction resistance at the interface. The ratio of ultimate loads of bonded to unbonded beams was correlated to the compressive strength of the LC. The ultimate loads of the beams exhibiting full composite action (bonded SLWAC and all ALWAC beams) were ranked according to the LC density (see Table 3), with highest values for beams with highest density. This trend was neither correlated to the distribution of the LC compressive strength nor the LC splitting tensile strength. The beams with anchor blocks reached similar ultimate loads to those of beam 1000E, indicating that the additional bonding of the FRP-LC interface was not necessary.

## Experimental investigations of short-span beams

### Results

The load-deflection responses of representative specimens are shown in Figure 8, while Table 4 summarizes the ultimate loads and the loads at the first visual crack. For both unbonded SLWAC specimens (1300s-1/2), the load-deflection response was almost linear up to a load of 40 kN, where a vertical crack appeared next to the mid-span. Subsequently, the LC started to be pushed out of the FRP sheet at the specimen end and stiffness decreased significantly. However, the load could be slightly increased up to the ultimate load of 145 kN on average. At this load, the outer T-webs of the FRP sheet exhibited a shear failure at the support. Figure 9 illustrates the crack pattern of specimen 1300s-1 at ultimate load.

Beam	Ultimate load [kN]	Cracking load at first visual crack [kN] * diagonal crack ** vertical at mid-span
1300s-1/2	143 / 146	40** / 40**
900Es-1/2	98 / 83	75* / 80*
1300Es-1/2	204 / 185	85* / 85*
1000s/1000Es	164 / 201	44* / 35*

Table 4 Ultimate loads and LC cracking loads based on visual observation

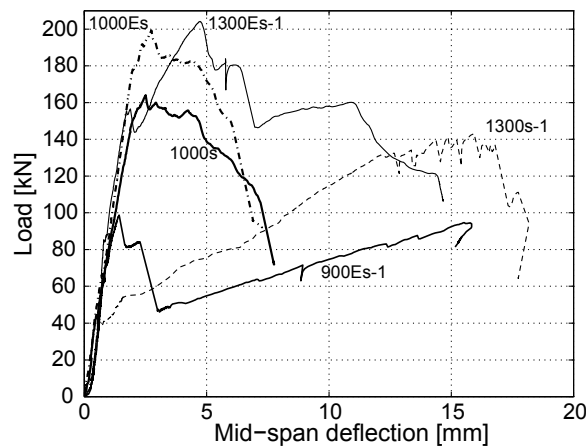

Figure 8 Load-deflection responses of beams

For the bonded SLWAC specimens 900Es-1/2, a first diagonal crack appeared at 77.5 kN on average. With increasing load, this crack propagated steadily through the whole LC layer, and the average ultimate load was reached at 90.5 kN. Subsequently, a horizontal crack propagated along the FRP-LC interface towards the end of the specimen, when the experiment was stopped. In the case of specimen 1300Es-1, the first visible diagonal crack in the LC occurred at approximately 85 kN. Subsequently, the load could be increased up to the ultimate load of 204 kN, where failure occurred just above the FRP-LC and in the LC-NC interface. Specimen 1300Es-2 behaved similarly to 1300Es-1. The first diagonal crack in specimen 1000s was visible at 44 kN. At 150 kN, the stiffness decreased and slippage was measured. However, the load could be increased until the ultimate load was reached at 164 kN. Specimen 1000Es showed an almost linear response up to a load of 180 kN although the first diagonal crack was already observed at 35 kN. Subsequent to this first crack, a pattern of diagonal cracks developed progressively on both sides until the ultimate load was reached at 201 kN. The failed bonded 1000Es specimen is shown in Figure 9.

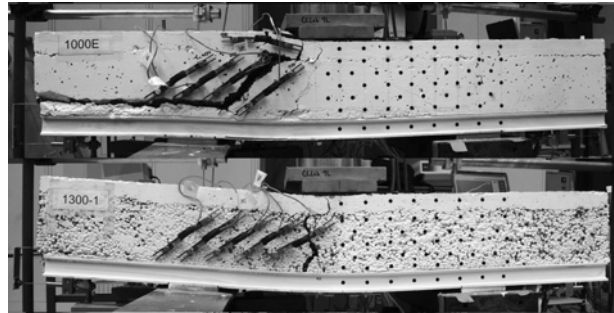

Figure 9 Typical failure patterns of bonded beams (ALWAC 1000Es above) and unbonded SLWAC beams (1300s-1 below)

### Discussion

The unbonded beams 1300s-1/2 lost composite action in the FRP-LC interface just after LC cracking. Slippage between FRP and LC was measured from this load on indicating that the interface was too weak to provide a support for the compression diagonals, which led to the single crack at mid-span. The unbonded beam 1000s exhibited different behavior: composite action was maintained after cracking up to approximately 91% of the ultimate load. This improvement was attributed to the much higher compressive strength of the ALWAC mixture, which increased the friction resistance at the interface. The bonded beams exhibited full composite action up to ultimate load which was significantly higher than the corresponding load for the unbonded specimens.

The cracking loads of the SLWAC specimens were significantly higher than those of the ALWAC specimens, see Table 4. However, no correlation between cracking load and LC splitting tensile strength was found. This was already observed in the beam experiments and was attributed to the more brittle behavior of the ALWAC concrete compared with that of the SLWAC mixture. Cracking always started approximately in the middle of the compression diagonal, where maximum transverse deformations due to tension were measured.

With the exception of the unbonded specimens 1300s-1/2, direct load transmission occurred through the compression diagonal. However, no correlation between LC compressive strength and ultimate failure load was found. The comparison of ultimate loads with LC splitting tensile strength resulted in a much better correlation

The direct load transmission and beam experiments showed similar results concerning the effects of interface type (composite action) and LC brittleness. Figure 10 compares the ultimate loads of the corresponding specimens and beams of both experimental series. The former were significantly higher (4.3 times on average) than the latter, as could be expected.

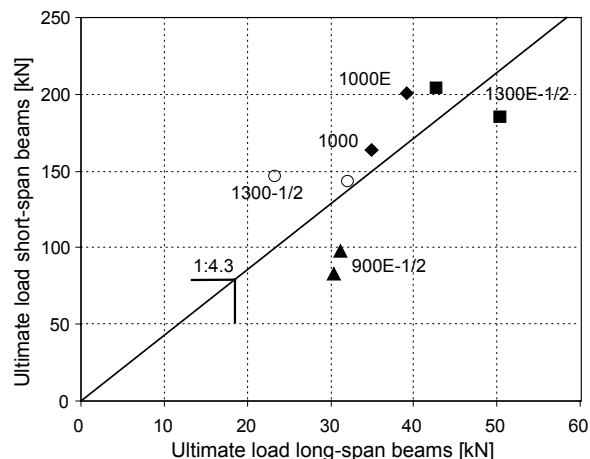

Figure 10 Ultimate load short-span beams vs. ultimate load long-span beams

### 11.2.3 MODELING OF BEAM SHEAR STRENGTH

A shear strength prediction for the long-span beams was firstly performed according to the shear resistance equation provided in Eurocode2, see also to D3.4. Only beams exhibiting full composite action up to failure were considered. The ultimate beam loads,  $F_{u,pred,EC}$ , and their accordance with the experimental results are summarized in Table 5, while Figure 11 illustrates the results versus the LC compressive strength. The experimental ultimate loads of the SLWAC beams were overestimated by 19 % on average, and those of the ALWAC beams by up to 67 %. This result, together with the poor correlation between ultimate beam load and LC splitting tensile strength, led to the conclusion that the shear behavior of the hybrid beams could not be predicted solely on the basis of LC mechanical strength properties such as compressive or tensile strength.

Hence a refined shear model originally developed by Zink for normal and high-performance concrete and including fracture mechanics properties was used to calculate the shear resistance of the hybrid sandwich beam,  $V_{lc,Rm}$ , and thus the ultimate beam load,  $F_{u,pred,Zink}$ .

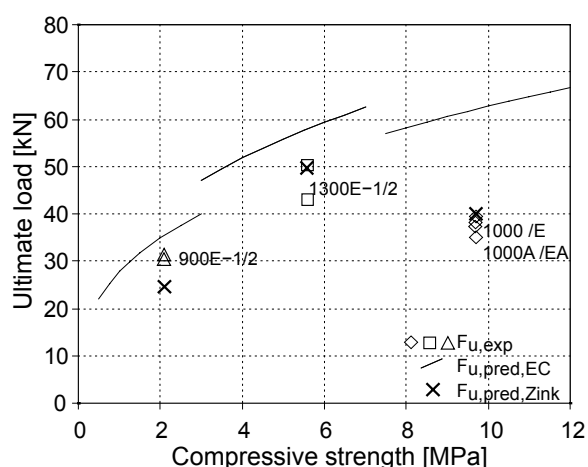

Figure 11 Ultimate beam loads: experimental ( $F_{u,exp}$ ), predictions according to EC2 ( $F_{u,pred,EC}$ ), and refined shear model based on original by from Zink ( $F_{u,pred,Zink}$ )

Beam	$F_{u,exp}$ [kN]	$F_{u,pred,EC}$ [kN]	$F_{u,pred,EC}/F_{u,exp}$ [-]	$F_{u,pred,Zink}$ [kN]	$F_{u,pred,Zink}/F_{u,exp}$ [-]
900E-1/2	31.2 / 30.4	35.4	1.14 / 1.17	24.6	0.79 / 0.81
1300E-1/-2	42.8 / 50.5	57.8	1.35 / 1.15	48.8	1.14 / 0.97
1000/1000E	35.0 / 39.2	62.0	1.77 / 1.58	28.6	1.10 / 0.98
1000A/1000EA	37.8 / 37.2	62.0	1.64 / 1.67	28.6	1.02 / 1.04

Table 5 Ultimate load prediction according to EC2 and shear prediction method based on a refined version of Zink's model

Figure 12 shows the components that contribute to the shear resistance of the beam, obtained through interpretation of Zink's model and expressed in the following equation:

$$V_{lc,Rm} = V_{nc} + V_{lc} + V_{FPZ} = \left[ \frac{2}{3} \cdot d_{nc} + (x_n - d_{nc}) + \frac{2}{5} \cdot \cos 45^\circ \cdot 0.4 \cdot l_{ch} \right] \cdot b_w \cdot f_{lct,m} \quad (1)$$

where  $b_w$  = beam width,  $V_{nc}$  = shear portion transferred in NC layer (thickness  $d_{nc}$ ),  $V_{lc}$  = shear portion transferred in LC core (above the neutral axis, at depth  $x_n$ ),  $V_{FPZ}$  = shear portion transferred in the fracture process zone (FPZ) where the concrete can bridge the cracks and transmit tensile forces. The length of the FPZ, defined as being 0.4 times the LC characteristic length, is hence much longer for the SLWAC than for ALWAC compositions. The shear strength of the LC at the neutral axis,  $t_{xy,u}$ , can be defined as being equal to the tensile strength  $f_{lct,m}$ , which is approximately 90% of the splitting tensile strength.  $V_{nc}$  and  $V_{lc}$  can then be calculated according to Eq. (1).

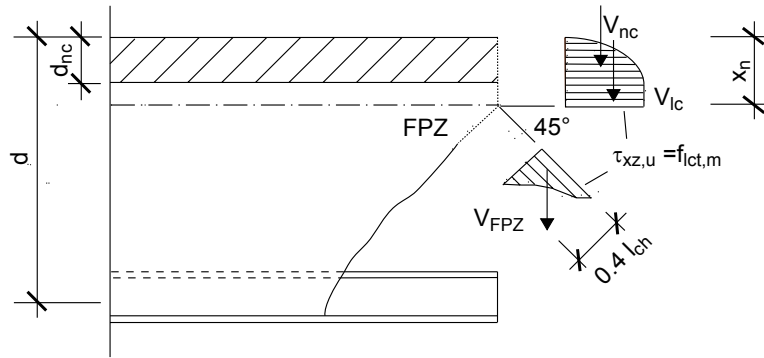

Figure 12 Shear resistance components in hybrid sandwich beams

The refined shear model provides good agreements between predicted and ultimate loads due to the consideration of both LC splitting tensile strength and LC characteristic length (98% on average see Table 5 and Figure 11). Furthermore, the shear strength prediction method offers a basis for optimizing LC material characteristics for any load condition by adapting splitting tensile strength and characteristic length to specific requirements.

#### 11.2.4 DESIGN CONCEPT

A design concept for the proposed hybrid FRP-concrete sandwich bridge deck was developed based on the previously described experimental and analytical investigations and presented in detail in D3.5. Here, the serviceability of the deck is verified in regions of maximum deflection, while structural safety is verified on the basis of the design moments and shear forces. First, the bridge deck flexural capacity is verified by comparing the maximum compressive and tensile stresses in the face layers (due to the design moments) with the respective material design strengths. Second, shear resistance is assessed in three critical sections: in the field, under concentrated loads (punching) and adjacent to the support.

The shear resistance of the slab in the field is determined using the fracture mechanics approach refined from Zink. As previously described, this prediction method was experimentally validated on 20-cm-deep hybrid beams consisting of three layers: FRP-LC-NC. It is assumed that the prediction method can be applied to predict the shear strength of hybrid slabs by slightly changing layer thicknesses and material properties.

To verify resistance to punching, the shear strength prediction method for the field is modified so that shear resistance is no longer calculated for one plane fracture surface but for a simplified punching pyramid of four fracture planes. However, based on experimental studies of hybrid slabs from Wuest (2007), an improvement of the ultimate load is expected due to the positively acting membrane forces of the UHPFRC layer. Therefore, the presented method for calculation of punching resistance is seen as a lower limit value and further investigation is required to quantify the increased punching resistance of the slab due to the additional contribution of the membrane forces of the FRP profile.

The proposed shear strength prediction method is no longer applicable for verification next to the support, where loads are directly transmitted through the compressive diagonals to the support. Therefore, verification of the shear design values next to the support is carried out in a first approach empirically based on the experimental results obtained from 20-cm-deep short-span beams. As shown in the experimental investigation, the average ratio between ultimate beam loads vs. the ultimate loads of direct load transmission is 1:4.3. In this first approach, it is hence assumed that the 1:4.3 ratio is also valid for other slab thicknesses. However, further investigation is required to prove this first approach assumption for higher slab thicknesses.

Detailed design examples of FRP-concrete hybrid bridge decks, presented in D3.5, showed that the controlling verification is the LC shear resistance verification in the field. It was shown that the experimentally investigated LCs could not be used for 40-cm-deep bridge slabs with a girder spacing

greater than 2 m. For other applications, appropriate LC types were therefore defined to fulfill the design requirements for a 12-m-wide bridge with 6-m girder spacing and bridge loads according to EC1 load model 1. Hence, the required LC characteristic length and LC splitting tensile strength were determined for slab thicknesses of 20, 30, 40 and 50 cm. The resulting values are shown in Figure 13. For the same slab thickness, the required LC splitting tensile strength decreases for increasing characteristic length. Furthermore, it is noticed that for different slab thicknesses and short characteristic lengths, the LC splitting tensile strength varies more significantly than for longer characteristic lengths. Reducing the thickness from 40 to 20 cm for example almost doubles the required splitting tensile strength for  $l_{ch} = 20$  mm, while it increases by only 57% for  $l_{ch} = 200$  mm. This is because the characteristic length is a constant value that is independent of slab thickness. The lower the characteristic length/slab thickness ratio, the higher the required splitting tensile strength. Consequently, shear resistance does not grow increase proportionally to the slab thickness.

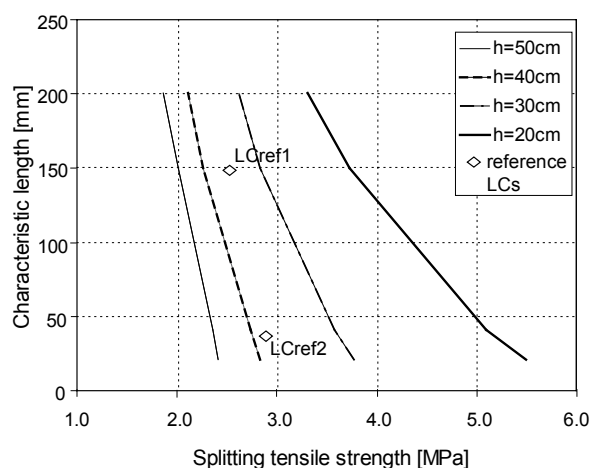

Figure 13 Characteristic length vs LC splitting tensile strength for 12-m-wide bridge slab with 6-m girder spacing to fulfill design requirements for different slab thicknesses and experimentally investigated LCref1 and LCref2 from Wille (2005) and Faust (2002)

Furthermore, D3.5 presented LC compositions investigated by Wille (2005) and Faust (2002), which fulfilled the required LC characteristics. In Figure 13 two of these LCs are marked as diamonds: LCref1 with  $f_{lctsp} = 2.5$  MPa,  $l_{ch} = 150$  mm and LCref2 with  $f_{lctsp} = 2.9$  MPa,  $l_{ch} = 37$  mm. Both LCs would provide sufficient shear resistance for a 40-cm-thick slab. However, the specified LC densities reached values of up to 1600 kg/m<sup>3</sup> and the bridge deck would therefore not attain the target total weight of 50% of that of a normal concrete deck. For a 40-cm-thick slab, an LC density of approximately 1100 kg/m<sup>3</sup> would be required.

## 11.2.5 CONCLUSIONS

Experimental and analytical investigations on the proposed hybrid bridge deck demonstrated the feasibility of the concept. The sandwich structure consists of three layers of different materials: a fiber-reinforced polymer (FRP) composite sheet with T-upstands for the tension skin, lightweight concrete (LC) as a core material and ultra-high performance fiber-reinforced concrete (UHPFRC) for the compression skin. Due to the steel-free LC core, the deck exhibits advantageous properties such as low self-weight and substantial resistance to corrosion. In particular, the prefabrication and low self-weight offer the possibility of rapid deck replacement with minimum traffic interference or simplicity of installation for new constructions.

An experimental study on short-span and long-span hybrid sandwich beams was performed. The top skin was a 30-mm normal concrete (NC) layer, while for the bottom GFRP skin, standard pultruded Plank 40HDx500 elements from Fiberline were used. The sandwich core consisted of two different types of lightweight concretes (LC): an SLWAC mixture with expanded clay and sand aggregates and an ALWAC mixture with expanded clay and expanded glass aggregates. Furthermore, two types of FRP-LC interfaces were investigated: pure mechanical interlocking between FRP T-upstands and LC

and adhesive bonding of the FRP-LC interface using an epoxy adhesive. In the case of the two long-span ALWAC beams, the total beam depth over the supports was cast with NC (anchor blocks with epoxy-bonded FRP-NC interface) in order to prevent FRP-LC slippage at the beam ends. The following conclusions were drawn from the experimental observations:

- All beams exhibited shear failure in the LC core. The ultimate loads of all long-span beams were not correlated to LC compressive strength or splitting tensile strength. For the same LC type, beam stiffness and ultimate loads depended on the type of FRP-LC interface, the highest values being obtained for the adhesively-bonded interface and the lowest for the unbonded mechanical interlocking between LC and FRP T-upstands. The unbonded SLWAC beams showed a ductile failure behavior, while all the other investigated beams exhibited a brittle shear failure. The shift from ductile to brittle failure mechanism appears to depend on LC compressive strength. The use of normal concrete anchor blocks with bonded NC-FRP interface can be considered an alternative to the adhesive bonding of the whole FRP-LC interface.
- A correlation between the short-span ultimate loads and LC splitting tensile strengths was found. The cracking load, however, did not exhibit a similar correlation; the cracking loads of the more ductile SLWAC compositions were significantly higher than those of the more brittle ALWAC mixtures, although splitting tensile strengths were similar.
- Long-span and short-span beam experiments showed similar results concerning the effects of interface type (composite action) and LC brittleness. The ultimate loads or shear resistances of the former were significantly higher (4.3 times on average) than those of the latter, since loads were transmitted by a compression diagonal directly to the support. The compression diagonals of the beam experiments interfered with crossing tension diagonals, which lowered the ultimate loads (or shear resistances).

A refined fracture mechanics-based shear strength prediction model originally developed for normal and high-performance concrete that considers the shear resistance of the fracture process zone (FPZ) was developed to predict the shear resistance of hybrid beams exhibiting composite action until failure. Good agreement between predicted and ultimate loads was achieved underlining the importance of considering both LC splitting tensile strength and LC characteristic length.

Moreover, a design concept for a hybrid FRP-concrete sandwich bridge deck was proposed incorporating the shear strength prediction model. In addition to demonstrating the feasibility of the system, the concept also provides a basis for optimizing LC material characteristics for any load condition. Thus, the same range of bridge spans is possible as for conventional steel-reinforced concrete bridge slabs by adapting LC properties (splitting tensile strength and characteristic length) to the required strength. With regard to bridge design examples in particular, it was demonstrated that the shear strength prediction in the field was the controlling verification. Furthermore it was shown that different LC compositions investigated by Wille (2005) and Faust (2002) would be applicable for a typical 12-m-wide bridge with 6-m girder spacing and slab thicknesses of 40 cm. However, the relatively high densities of these LCs would not allow the target total weight of 50% of a normal concrete deck to be attained. The experimentally used LCs however - offering the target LC density - did not provide sufficient resistance for a transverse girder spacing of more than 2 m. An optimization of the experimentally used LC1000 composition should thus be conducted. The addition of fibers could possibly increase the LC characteristic length and splitting tensile strength by maintaining the LC density of approximately 1000 kg/m<sup>3</sup>. Furthermore, an optimization of the LC-FRP mechanical interlocking behavior should be investigated in order to provide a ductile failure mechanism, as observed for the unbonded SLWAC beams. Since the shift from ductile to brittle failure mechanism in the unbonded beams is seen to depend on LC compressive strength, an optimization study of the FRP T-upstand geometry and configuration together with the LC compressive strength should be performed.

## Acknowledgements

The authors wish to acknowledge the support of Fiberline Composites A/S, Denmark, supplier of the GFRP Plank elements; Sika AG, Zurich, Switzerland, supplier of the epoxy adhesive; Liapor, Switzerland, supplier of the LC concrete; and Prebeton SA, Avenches, Switzerland, for the fabrication of the beams.

## REFERENCES

- Eurocode 1, Actions on Structures – Part 2: traffic loads on bridges, EN 1991-2, September, 2003.
- Eurocode 2, Design of concrete structures - Part 1.1: General rules and rules for buildings, EN 1992-1-1, 2004.
- Faust, T.: Leichtbeton im konstruktiven Ingenieurbau, Ernst & Sohn, Berlin, 2002, 307pp. (In German)
- Fiberline Composites A/S, <<http://www.fiberline.com>>, (2006)
- Keller T, Schaumann E, Vallée T.: Flexural behavior of a hybrid FRP and lightweight concrete sandwich bridge deck. In: Composites Part A 2007; 38; 879–889.
- NR2C WP3 Report D3.4
- NR2C WP3 Report D3.5
- Schaumann E, Vallée T, Keller T.: Shear Resistance of lightweight concrete core of FRP-concrete sandwich structure. In: ACI Materials Journal, submitted.
- Schaumann E, Vallée T, Keller T.: Direct load transmission in hybrid FRP and lightweight concrete sandwich bridge deck. Composites Part A. doi:10.1016/j.compositesa.2007.12.004.
- Wille, K.; Dehn, F.M., Tue, N.V.: Bruchmechanische Kenngrößen hochfester Leichtbetone. In: Bauingenieur, V. 80, No. 6, pp. 327-333, 2005. (In German)
- Wuest, J., “Comportement structural des bétons de fibres ultra performants en traction dans des éléments composites,” PhD Thesis no. 3987, Ecole Polytechnique Fédérale de Lausanne (EPFL), 2007.
- Zink M.: Forschung für die Praxis - Zum Biegeschubversagen schlanker Bauteile aus Hochleistungsbeton mit und ohne Vorspannung. B.G. Teubner Stuttgart Leipzig 2000, ISBN 3-519-00322;. (In German)

### 11.3 Study of solutions for bridge decks made of Ultra-High Performance Fibre-Reinforced Concrete (UHPFRC) and composite materials (glassfibre)

Jacques RESPLENDINO, S. BOUTEILLE (CETE de Lyon - France)

#### Abstract

This article presents the results of research conducted within the scope of European Project NR2C (New Road Conception Concept). The aim of the study was to develop future-oriented solutions for the construction of bridges using new materials to their best advantage in terms of durability and sustainable development.

The studies described in this article focus on bridge deck solutions using Ultra-High Performance Fibre-Reinforced Concrete, composites (glassfibre) and steel.

After presenting the assumptions made for the material properties and the geometrical and functional data for the bridges studied, the main computational models developed for transfer of the general loads, and the transverse and local functioning of the bridges are described.

For each solution studied (10 and 25 metre span), the article presents the approach selected to optimise the properties of the novel solutions proposed, the construction and assembly methods envisaged, and the cost of building the bridges in the current economic context.

In conclusion, it determines the research areas which need to be pursued in relation to the work already carried out.

#### 11.3.1 GENERAL FRAMEWORK OF STUDY

The research was conducted within the scope of European project NR2C (New Road Conception Concepts). The aim of the study was to find future-oriented solutions for the construction of bridges using new materials to their best advantage in terms of durability and sustainable development.

The studies described in this article focus on bridge deck solutions using Ultra-High Performance Fibre-Reinforced Concrete, composites (glassfibre) and active and/or passive steel reinforcements.

The study concerns two types of bridges: those with a 10-metre span for small crossings, and those with a 25-metre span which corresponds to half the length of a motorway overpass.

The bridges studied are designed for dual carriageways and respect the traffic loads set out in the Eurocode (EN 1991-2).

#### 11.3.2 GENERAL ASSUMPTIONS

##### Cross-section and components of structure

The bridges studied have a 7.5 m wide road surface and a pedestrian pavement on either side with an effective width of 1 m. The cross-section has a single slope (Fig 1).

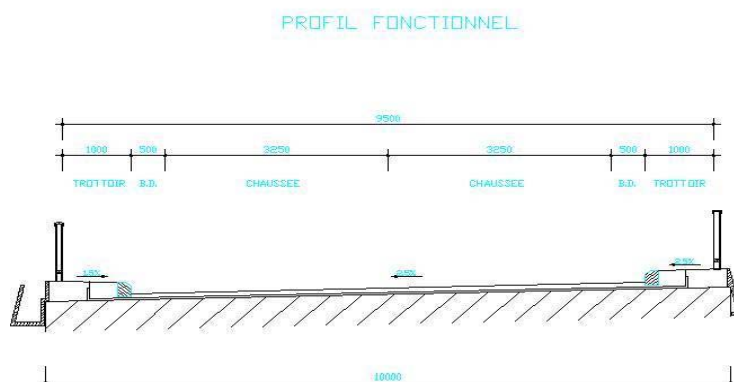

Fig 1 – Functional cross-section of the bridges studied

To calculate the weight of the permanent loads, the road slab is assumed to be covered with a waterproofing layer and an 11-centimetre road surface.

The pedestrian pavements have a thickness of about 30 cm. The bridge has a hand rail and a gutter to evacuate muddy water.

### Load assumptions

#### *Dead loads*

The nominal weight of the superstructures is about 4.53 t/m for minimum and maximum values of 5.69 t/m and 3.98 t/m respectively.

#### *Operating loads*

The bridge is assumed to be subject to EN 1991-2 traffic class 2.

The LM1 and LM2 load systems are applied to the bridge.

#### *Thermal loads*

A thermal gradient of 15°C is assumed in the case of entirely UHPFRC solutions. In mixed UHPFRC-composite or steel solutions, a differential expansion of +/-10°C between the two materials is assumed.

### Combined actions

These correspond to the Eurocode provisions.

If  $G_{min}$  and  $G_{max}$  are the favourable and unfavourable permanent actions, if  $gr_1$  is the combined operating load i.e. TS plus UDL, and  $T$  is the temperature action, the load combinations will be as follows:

$$\begin{aligned} \text{ULS:} & \quad 1.35 G_{max} + G_{min} + \text{MAX}\{(1.35gr_1) \text{ and } (1.5T+1.35(0.75TS+0.4UDL))\} \\ \text{Characteristic SLS:} & \quad G_{max} + G_{min} + \text{MAX}\{(gr_1+0.6T) \text{ et } (T+0.75TS+0.4UDL)\} \\ \text{Frequent SLS:} & \quad G_{max} + G_{min} + \text{MAX}\{(0.6T) \text{ and } (0.5T+0.75TS+0.4UDL)\} \\ \text{Quasi-permanent ELS:} & \quad G_{max} + G_{min} + 0.5T \end{aligned}$$

### Assumptions in relation to materials

#### *UHPFRC*

The mechanical property assumptions made for UHPFRC, in accordance with the provisions of the AFGC SETRA recommendations [1], are as follows:

Characteristic compressive strength at day 28	150 Mpa
Characteristic direct tensile strength of the cement matrix at day 28: $f_{t28}$	8 Mpa
Characteristic direct tensile strength after cracking at day 28: $\sigma_{bt}$	8 Mpa
Young's modulus $E$	50 000 MPa
Poisson's ratio	0.2
Thermal expansion coefficient	$1.1 \cdot 10^{-5} \text{ m/m/}^\circ\text{c}$
Endogenous shrinkage Not taken into account in the case of post-tension prefabricated solutions	3 to $4 \cdot 10^{-4} \text{ m/m}$

Drying shrinkage	1.1.10 <sup>-4</sup> m/m without HT 0m/m if HT
Creep	Φ=0.8 without HT Φ =0.2 if HT

HT: Heat Treatment

#### *Composite material*

The mechanical property assumptions made for multilayer glassfibre + resin composite materials are as follows:

Density	1.15 t/m <sup>3</sup>
Young's modulus	25 000 Mpa
Breaking stress	500 Mpa
Elongation at break	2.1%

#### *Prestressing*

Tendons consisting of T15S class 1860 strands are used for the external prestressing.

### **Main calculation models produced**

All the structural calculations were carried out using SETRA's ST1 software. The stresses in the UHPFRC sections were verified against the provisions of the AFGC-SETRA recommendations using the INCA software package.

For fully prestressed structures, two successive models were developed for the design calculations in order to optimise the design:

- A first 2D model was used to dimension the main inertia of the slab and the tendons. This model includes the transverse strength based on the transverse increase factors proposed in the Guyon Massonnet method.
- A 3D model was then used to check the transverse behaviour, dimension the transverse ribs and check the transverse increase factors used initially.

For solutions using Vierendel trusses and lattice girders, three successive calculations models were developed:

- an STI 2D model with a uniform cross-section. This model was used to validate the overall characteristics of the cross-section and deflection under variable loads,
- an STI 2D model with Vierendeel trusses and lattice girders was used to dimension the verticals and validate the design of the notched sections of the slab,
- a 3D model was used to dimension the transverse components and validate the general design proposed.

### **11.3.3 DECK SOLUTIONS FOR A 10-METRE SPAN BRIDGE**

#### **Prestressed UHPFRC slab solution**

##### *Geometrical characteristics*

The structure studied is an Ultra-High Performance Fibre-Reinforced Concrete (UHPFRC) waffle slab, consisting of longitudinal and transverse ribs in a 60 cm x 60 cm square grid.

The road slab is 5 cm thick. The longitudinal ribs have an average thickness of 8 cm and a total height of 47.5 cm. The transverse ribs have an average thickness of 8.5 cm and a total height of 38 cm.

The cross-section of the structure was dimensioned to obtain a main deflection ratio of 1/350th of the span at a characteristic SLS.

The deck is prestressed longitudinally using external tendons consisting of 12T15S tendons between the longitudinal ribs.

Since the dead loads on the bridge are very low, the tendons are positioned approximately at the lower limit of the central node of the cross-section, which limits the prestressing force required to

transfer the stress at the ultimate load strength, while avoiding excessive prestressing in the bridge when not loaded. The tendons are rectilinear, or slightly deviated, in order to facilitate end anchoring and improve the shear force transfer.

*Deck assembly methods*

Two methods of assembly were studied.

**Transversal joints**

The deck is made of four prefabricated panels laid across the width of the bridge (fig. 2). Since UHPFRC does not transfer any tensile stress at the transversal joints, longitudinal prestressing guarantees total compression between the panels.

With this design, there are 12 x 12T15S prestressing tendons.

However, because the prefabricated panels are laid across the entire width of the deck, the transverse deflection forces are transferred by the UHPFRC fibres, which means that no passive or active transverse reinforcements are needed in the transverse ribs.

From a construction viewpoint, the drawback of this solution is that it requires:

- either the use of centres to support the prefabricated panels before assembly by external prestressing,
- or assembly of the prefabricated panels in an area next to the bridge with lifting of the completed deck into position by crane, which is possible because the bridge weighs less than 50 tonnes.

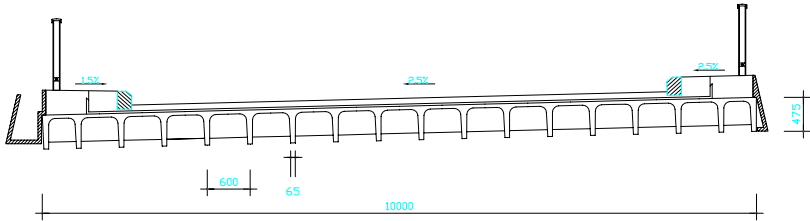

Fig 2 – Cross-section – 10-m solution – prestressed UHPFRC with transversal joints

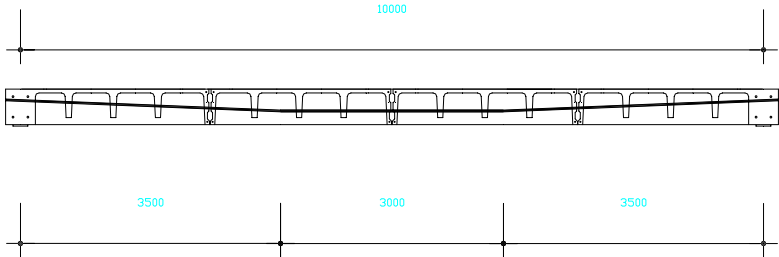

Fig 3 - 10 m solution – prestressed UHPFRC with transversal joints longitudinal section and elevation of tendons



## Longitudinal joints

This solution comprises the prefabrication of 10 m long girders with a width of 1 m 80 or 2 m 30. The girders are connected longitudinally at specific longitudinal ribs equipped with keys (fig 4). This means that the tensile strength of the UHPFRC is used to transfer the longitudinal deflection forces and that the number of longitudinal tendons is reduced to 8 x 12T15S tendons.

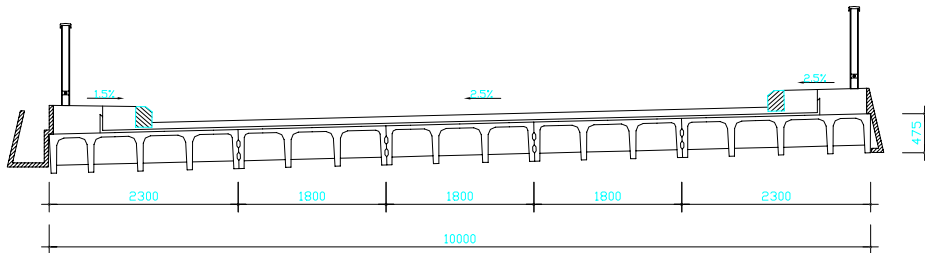

Fig 4 - Cross-section – 10 m solution – prestressed UHPFRC with longitudinal joints

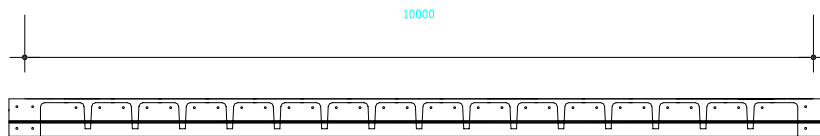

Fig 5 - 10 m solution – prestressed UHPFRC with longitudinal joints – longitudinal section with elevation of tendons and view of transverse prestressing

However, this solution requires the use of prestressing or transverse reinforcements to transfer the deflection forces in the transverse ribs at the longitudinal joints equipped with keys.

To transfer the transverse deflection forces, it is therefore necessary:

- either to use external transverse prestressing consisting of 2 x 3T15S tendons per rib approximately (centred full prestressing – fig 5),
- or to use passive reinforcement joints consisting of 4  $\Phi$  8 in the overslab and 2  $\Phi$  16 in the web for each transverse rib (fig 6)

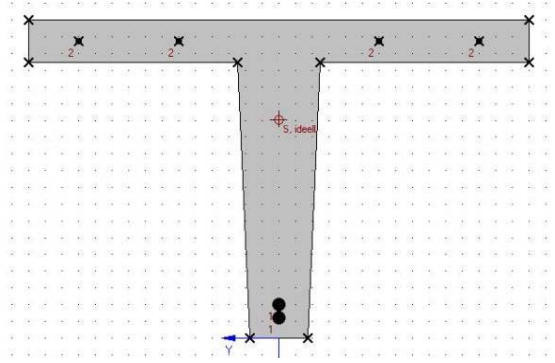

fig 6 : Cross-section of a passive reinforcement joint for a transverse rib.

From a construction viewpoint, the advantage of this solution is to that the girders can be placed directly on their final supports, before the transversal joints are made.

This eliminates the need for centres and enables the bridge to be erected on-site in a very short time.

For the fully prestressed solution (longitudinal and transverse prestressing), the gain in terms of longitudinal prestressing resulting from participation of the UHPFRC in the longitudinal deflection is largely compensated for by the transverse prestressing which leads to a higher level of prestressing in the long term.

#### *Overall savings obtained by these solutions*

These solutions lead to considerable savings in terms of materials.

The equivalent slab thickness is about 16.4 cm, which corresponds to a UHPFRC volume of 17 m<sup>3</sup>, for about 1700 kg of prestressing.

Under current economic conditions, the cost of the deck only is € 510 incl. VAT per m<sup>2</sup>.

### **UHPFRC and composite notched waffle slab**

#### *Geometrical characteristics*

The structure studied is a UHPFRC waffle slab combined with glassfibre (in the form of 0.03 m thick sheets) which transfers the tensile stress to the bottom fibre.

The road slab is 5 cm thick. The longitudinal and transverse ribs form a 60 cm x 60 cm grid. The longitudinal ribs are notched, with an average thickness of 15 cm and a total height of 53.5 cm. The transverse ribs have an average thickness of 8.5 cm and a total height of 38 cm.

Since the slab is not prestressed, the longitudinal ribs are notched to limit tensile stress in the UHPFRC of the ribs, and the glassfibre is connected to the longitudinal ribs by verticals which turn it into a Vierendeel girder system.

Since the Young's modulus of the glassfibre is relatively low, the height of the longitudinal ribs must be increased to respect the deflection conditions at SLS. If the sections are to be kept at a reasonable height, in order to respect the height of the verticals, the composite cannot be loaded satisfactorily and is mainly dimensioned to meet the stiffness requirements. The tensile stress in the glassfibre remains low (40 MPa at SLS, 54 MPa at ULS).

Initially, the notches were designed so that in the notched section, the concrete in the ribs is placed directly above the centre of gravity of the composite section. But in reality, the structure is complex and several parameters must be taken into account to obtain satisfactory dimensioning.

In the “verticals”, the shear force is very high, causing deflection and parasitic forces in the longitudinal ribs. Because of these parasitic forces, the following must be taken into account when dimensioning the longitudinal ribs:

- below a certain rib height, the local deflection between the verticals, combined with the parasitic forces from the verticals, causes unacceptable forces in the ribs,
- above a certain height, the presence of concrete below the centre of gravity of the composite section causes unacceptable forces in relation to the general bending stress of the slab.

Furthermore, if an adhesive connection is chosen between the two materials, the surface must be sufficient to reduce the shear stress to about 2 MPa.

Optimisation of all the above parameters results in a length of 0.40 m for the verticals, which have the same width as the ribs i.e. 0.150 m. The total height of the longitudinal ribs varies from 0.535 to 0.20 m in the notched areas.

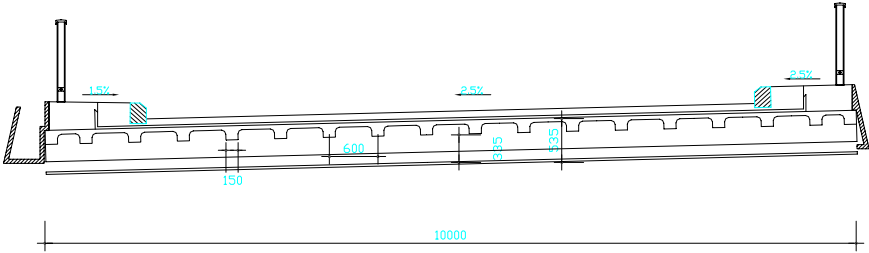

Fig. 7 – Cross-section – 10 m solution – notched waffle slab made of UHPFRC and a composite

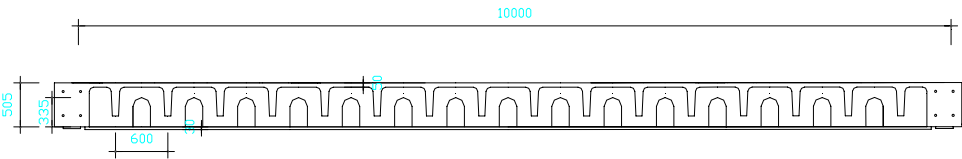

Fig. 8 – Longitudinal section – 10 m solution – notched waffle slab made of UHPFRC and a composite

### Deck assembly methods

Due to the presence of tensile stress in all the cross-sections of the UHPFRC longitudinal ribs, transversal joints are difficult to put into practice in this solution which rules out the possibility of constructing the bridge deck by placing several prefabricated panels across the width of the bridge. The solution proposed is to precast four or five 10-metre long girders and assemble them at the longitudinal joints formed between the longitudinal ribs (fig 9).

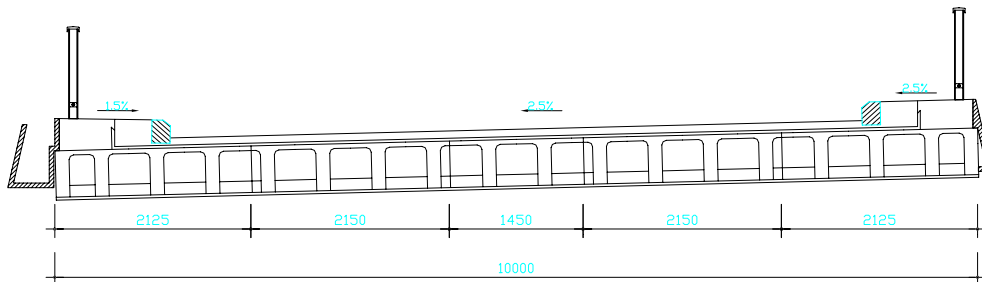

Fig 9 – 10 m solution – Notched waffle slab made of UHPFRC and a composite – suggested locations for the longitudinal joints

However, this solution requires the use of prestressing or transverse reinforcements to transfer the deflection forces in the transverse ribs at the longitudinal joints. The requirements are similar to those described for longitudinal assembly in the prestressing solutions, i.e.

- either external transverse prestressing consisting of 2 x 3T15S tendons per rib approximately (centred full prestressing),
- or passive reinforcement joints consisting of 4  $\Phi$  8 in the overslab and 2  $\Phi$  16 in the web for each transverse rib (fig 6).

*Overall savings obtained by these solutions*

These solutions are much less attractive than the above in terms of materials savings.

The increase in the height of the sections and reinforcement of the longitudinal ribs due to the Vierendeel girder configuration considerably increases the amount of UHPFRC required. The equivalent thickness is increased from 14.6 cm to 19.3 cm.

The amount of glassfibre used is also high (3450 kg) and under current economic conditions results in a cost of € 750 incl. VAT per square metre. for the deck only, i.e. an additional cost of 50% with respect to the fully prestressed UHPFRC solution.

### UHPFRC notched waffle slab with steel bottom flanges

#### *Geometrical characteristics*

The bridge studied is of the same type as that of the previous solution but steel plates are used as bottom flanges on the longitudinal girders instead of the composite material. Steel has a much higher

Young's modulus than a glass-fibre based composite (210 GPa against 25 GPa), which means that the geometry of the UHPFRC slab can be substantially modified and small quantities of materials used. The connection between the two materials is also different from that of the previous solution.

It is provided by dowels and a concrete penetration in the steel, which enables the geometry of the verticals to be optimised in order to obtain a constant tensile bending stress of about 15 MPa (fig 11) over their entire height.

Optimisation of these solutions results in the following characteristics. The steel plates are 0.03 m thick and 0.30 m wide. The total height of the slab is 0.41 m (fig 11). The longitudinal ribs have a total height of 38 cm and a thickness of 0.10 m. The verticals are 0.135 m high while their length varies from 0.12 m to 0.33 m (fig 12).

For architectural reasons and to protect the structure from environmental factors, the slab can be closed with a plate under the steel bottom flanges.

Just as for glassfibre solutions, the section of the bottom flanges is dimensioned to meet the stiffness requirements, and loading of the steel is not optimal. The stress in the steel is 115 MPa at SLS and 85 MPa at ULS.

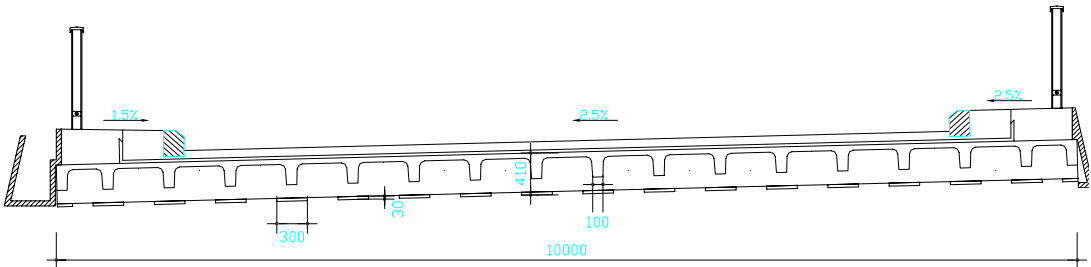
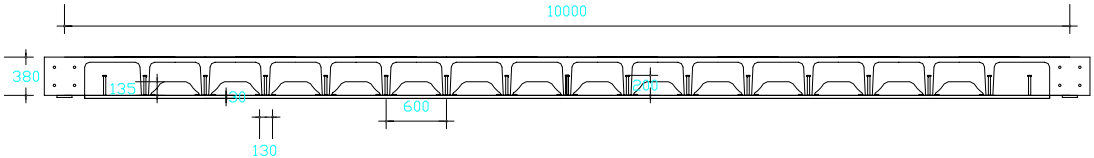

Fig. 10 - Cross-section – 10 m solution



notched waffle slab made of UHPFRC and steel bottom flanges

Fig. 11 - Cross-section – 10 m solution  
notched waffle slab made of UHPFRC and steel bottom flanges

### *Deck assembly methods*

The assembly method used for these solutions is similar to that of the notched UHPFRC waffle slab and composite solution.

The deck is made of four or five 10-metre long prefabricated girders, assembled at the longitudinal joints between the longitudinal ribs (fig 9).

### *Overall savings obtained by these solutions*

These solutions are halfway between the fully prestressed solutions and the composite material solutions. The equivalent thickness of UHPFRC is about 15.7 cm. The amount of structural steel required is about 12,000 kg.

Under present economic conditions, these solutions correspond to a cost of about € 670 incl. VAT per square metre, for the deck only.

## **11.3.4 DECK SOLUTIONS FOR A 25-METRE SPAN BRIDGE**

### **Prestressed UHPFRC slab solution**

#### *Geometrical characteristics*

The structure studied is an Ultra-High Performance Fibre-Reinforced Concrete (UHPFRC) ribbed slab. It has a 0.08 m thick overslab which rests on longitudinal ribs placed 1 metre apart, with a web thickness of 0.1 m and web height of 0.97 m, and on transverse ribs 1 metre apart, with a web thickness of 0.1 m and a web height of 0.5 m.

This geometry is designed to ensure that the deflection under a variable load does not go below 1/350th of the span, thus reducing the amount of longitudinal prestressing required.

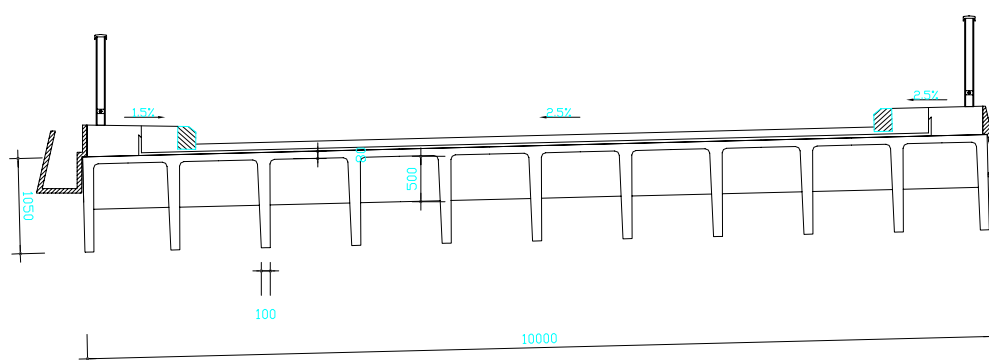

Fig 12 – Theoretical cross-section – 25 m solution – prestressed UHPFRC slab

The external prestressing consists of 18 x 12T15S tendons off-centre with respect to the centre of gravity of the 0.38 m cross-section at mid-span (fig 13).

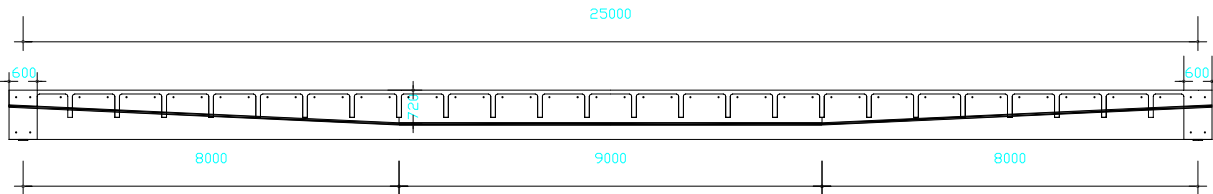

Fig 13 - 25 m solution – prestressed UHPFRC with longitudinal joints  
 - longitudinal section with elevation of tendons and view of transverse prestressing

*Structure assembly methods*

To assemble the structure, 2-metre wide full-span girders with joints near the longitudinal ribs (fig 14), compressed by centred prestressing consisting of 2 x 4T15S tendons per transverse rib, are used.

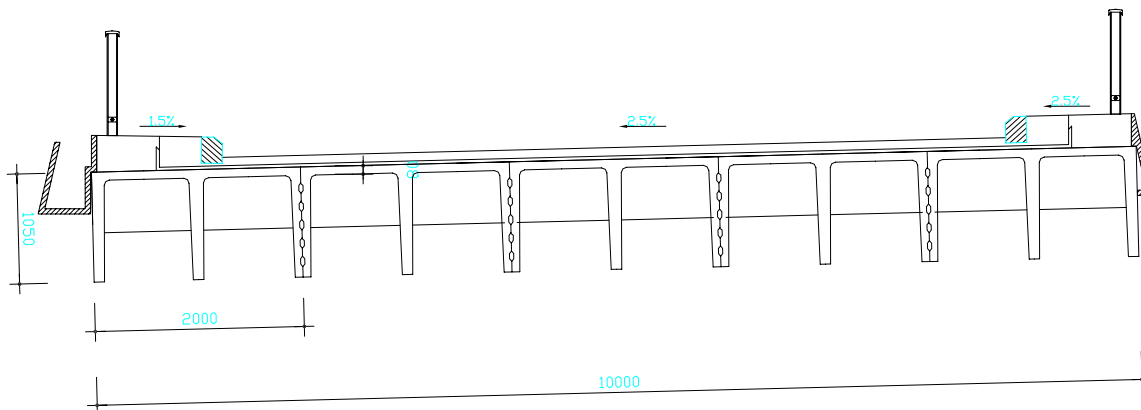

Fig 14 - 25 m solution – prestressed UHPFRC slab – transverse assembly solution

*Overall savings obtained by these solutions*

These solutions lead to relatively high savings in terms of materials.

The equivalent slab thickness is 23.3 cm, for about 6400 kg of prestressing. These quantities are consistent with the results obtained for the Bourg Lès Valence structures [2][3][4][5]. Under current economic conditions, the deck only costs € 670 incl. VAT per m<sup>2</sup>.

## Notched UHPFRC and composite waffle slab

### *Geometrical characteristics*

The structure studied here is a waffle slab made of UHPFRC combined with glassfibre. The design is based on the same approach as that described for the 10-metre span.

A total cross-section height of 1.30 m is obtained, i.e. a slenderness ratio of 1/20th of the span. The UHPFRC slab has a 0.08 m thick overslab, 0.25 m thick longitudinal girders and verticals (connection between the slab and composite) with a height of 0.91 m and a length of 0.70 m. The thickness of the transverse ribs is 0.1 m and their height is 0.50 m. The slab is coupled with a glassfibre-based multilayer composite with a total thickness of 0.05 m.

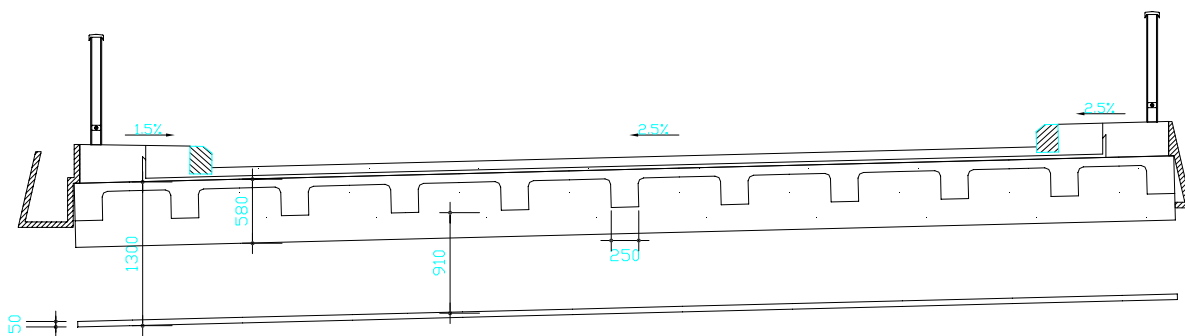

Fig. 15 - Cross-section – 25m solution – notched waffle slab made of UHPFRC and a composite

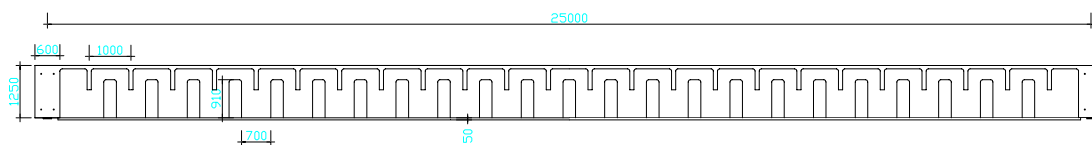

Fig. 16 - Longitudinal section – 25m solution – notched waffle slab made of UHPFRC and a composite

### *Structure assembly methods*

As for the 10-m span structures, longitudinal keying is recommended. The joints are made between the longitudinal ribs, because of the notches, and the components are connected either by steel bars (4  $\Phi$  10 in the overslab and 2  $\Phi$ 20 in the web), or by external transverse prestressing consisting of 2 x 5T15S.

### *Overall savings obtained by these solutions*

Like the 10-metre span structures, these solutions are much less advantageous than the prestressed solutions in terms of materials savings.

The equivalent thickness of UHPFRC increases from 23.3 cm to 36.4 cm.

The amount of glassfibre used is also high (14 375 kg) and under current economic conditions results in a high cost of € 1190 incl. VAT per square metre. for the deck only.

## **Notched UHPFRC and composite waffle slab with longitudinal prestressing**

### *Geometrical characteristics*

The geometry is the same as that of the previous solution, but external longitudinal deflected prestressing is added in order to save on materials.

The prestressing transfers the stresses caused by the dead weight. It is added before the glassfibre which transfers the stresses produced by the superstructures and operating loads.

This chronology prevents the composite from being compressed during the provisional phase and means that the prestressing reduces the stresses in the UHPFRC more effectively.

This design reduces the length of each vertical by 0.150 m. About 9.40 m<sup>3</sup> less UHPFRC is required. The thickness of the composite is reduced to three centimetres.

The prestressing consists of 8 x 12T15S tendons. The tendons are off-centre by 0.20 m in relation to the extruders at the anchoring point and 0.50 m at mid-span.

The principle of transverse assembly of the girders is identical to that described for the solution without prestressing.

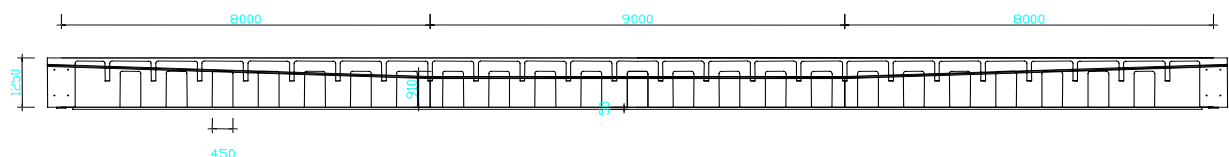

Fig. 17 - Longitudinal section – 25m solution – notched waffle slab made of UHPFRC and a composite

### *Overall savings obtained by this solution*

Although prestressing improves the economics of this solution, its performance remains low.

The equivalent thickness of UHPFRC is reduced from 36.4 cm to 32.7 cm.

The amount of glassfibre is reduced from 14 375 kg to 8620 kg while 2830 kg of prestressing is required.

The result is a notable decrease in the cost of the deck only, but the figure is still high at € 984 Including VAT per square metre. under current economic conditions.

### **UHPFRC and composite lattice slab**

#### *Geometrical characteristics*

Due to the difficulties encountered in reducing the amount of material required for structures with notched longitudinal ribs which form Vierendeel girders and are thus the site of parasitic forces which penalise the use of UHPFRC, the solution proposed here consists in improving the design of the connections between the slab and the composite.

UHPFRC offers more possibilities in terms of shape than traditional reinforced concrete which is penalised by the constraints relating to the forming of passive steel reinforcements.

UHPFRC can easily be used to produce a lattice structure consisting of 0.325 x 0.25 m diagonals (fig 18). The main beams have a total height of 1.30 m and 0.519 m in the notched areas. They are connected by transverse ribs every 1.30 metres.

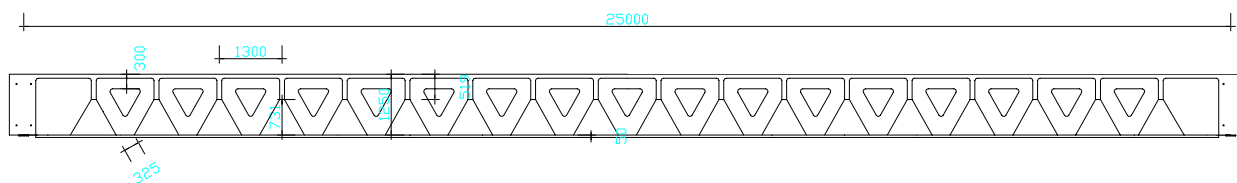

Fig. 18 - Longitudinal section – 25m solution – lattice slab made of UHPFRC and a composite

### Overall savings obtained by this solution

The lattice arrangement of the girder webs leads to a significant material gain compared with the Vierendeel system.

The equivalent thickness of UHPFRC is reduced from 36.4 to 29.8 cm.

The amount of glassfibre used is identical to that required for the notched ribbed solution.

However, using lattice girders is slightly less efficient than prestressing. Under current economic conditions, the cost of the deck only remains relatively high at € 1073 including VAT per square metre.

### UHPFRC lattice slab with steel footing

#### Geometrical characteristics

In order to save materials in relation to the previous solution, we examined a solution aimed at replacing the lower glassfibre tie with steel footing.

The thickness of the longitudinal ribs is reduced from 0.25 m to 0.20 m while the thickness of the longitudinal verticals remains the same at 0.325 m, since the ribs are subjected to normal stress and it is important to limit the resulting tensile stress. The slenderness ratio, the length of the verticals and the dimensions of the transverse ribs are the same.

The steel footing under the longitudinal ribs has a thickness of 0.03 m and a width of 0.50 m.

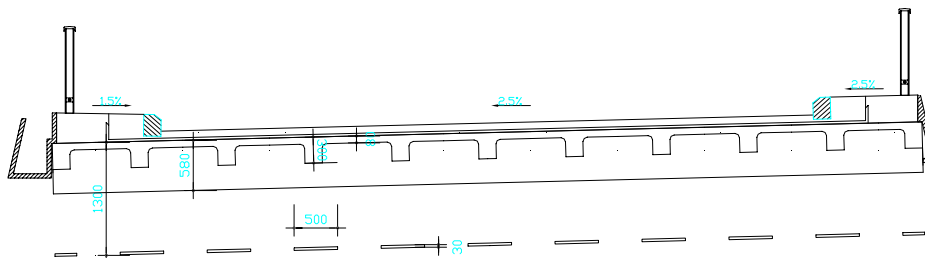

Fig. 19 - Cross-section – 25 m solution – lattice slab made of UHPFRC and steel footing

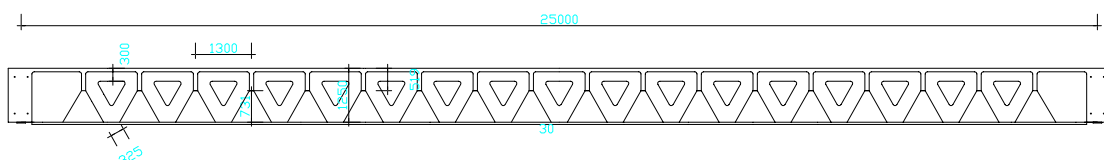

Fig. 20 - Longitudinal-section – 25 m solution – lattice slab made of UHPFRC and steel footing

### *Overall savings obtained by this solution*

The presence of a lattice web and steel ties confers a certain degree of economic interest on these solutions.

At 0.262 m, the equivalent thickness of UHPFRC becomes economically viable.

The amount of structural steel required is 32.4 tonnes.

The overall cost of this deck solution under current economic conditions is about € 814 incl. VAT per square metre, which is similar to the cost of the fully prestressed solution.

### **11.3.5 CONCLUSION**

This study has enabled us to explore solutions for 10 m and 25 m span bridge decks consisting of prestressed UHPFRC girders or mixed UHPFRC/composite and UHPFRC/steel girders.

It shows that the most advantageous solutions in terms of materials savings are fully prestressed UHPFRC decks. For 10-metre span structures, these solutions lead to financially viable structures under current economic conditions.

Mixed UHPFRC/glassfibre solutions are penalised by the poor ratio of the Young's modulus to the connection strength of the two materials which means that they have to be overdimensioned in order to respect the deflection requirements of the decks. If bridges are to be built that respect the strain conditions while loading both materials sufficiently, slender structures will have to be eliminated; the section height will be unattractive and cause problems in terms of the web design and the shear force transfer areas.

For 10-metre span bridges, notched web girders and steel footings are interesting alternatives to fully prestressed solutions.

Similarly, for 25-metre span bridges, the combination of UHPFRC and a composite can become advantageous in the case of partially prestressed UHPFRC prefabricated lattice beams.

As a follow-up to this study, reflection can be pursued on the design of assemblies that will optimise the general design and building of the bridges.

This reflection could include:

- the design of UHPFRC slab component assemblies in order to guarantee local stress transfer and water tightness of the slab,
- the design of UHPFRC and composite assemblies which could develop the adhesive bonding of systems that ensure the dispersion of concentrated stresses.

### REFERENCES

- [1] Bétons Fibrés à Ultra-Hautes Performances', Recommandations provisoires, Association Française de Genie Civil, Service d'Etudes Techniques des Routes et Autoroutes, January, 2002.
- [2] Resplendino J., Roy J.M., Petitjean J., Blondeau P., Hajar Z., Simon A., Thibaux T., "Ouvrages innovants de Bourg-lès-Valence", Revue Travaux, No.783, pp. 42-47
- [3] Thibaux T., Tanner J.A., "Construction des premiers ponts français en béton fibré à ultra hautes performances/construction of the first French road bridges in ultra high performance concrete", in La technique française du Béton, AFGC, The First FIB congress 2002, Osaka 2002
- [4] Hajar Z., Simon A., Lecointre D., Petitjean J., "Construction of the first road bridges made of UHPC", 3rd International Symposium on HPC, Orlando, 2003
- [5] J.Resplendino, S. Bouteille, "Les derniers développements dans l'utilisation des Bétons Fibrés Ultra Performants en France", AFGC Congress GC2005, Paris, 2005.

## **11.4 Detailed design and experimental validation of innovative aspects of a 10m - span composite UHPFRC – carbon fibres – timber bridge**

François TOUTLEMONDE (Univ. Paris Est / Labo. Central des Ponts et Chaussées LCPC – France)  
Othman BEN MEKKI (Univ. Paris Est / Labo. Central des Ponts et Chaussées LCPC – France)  
Presently at Ecole Nationale d'Ingénieurs de Tunis – ENIT - Tunisia  
Jean-François CARON (Univ. Paris Est / Institut Navier LCPC-ENPC / LAMI – France)  
Frédéric GENS (Bureau d'études Greisch SA – Belgium)

### **Summary**

The innovative bridge structure designed by Greisch SA according to the concepts developed within NR2C-WP3 was tested at LCPC. The 10 m-span element uses new materials (UHPFRC and FRP) combined with wood, a traditional environmental-friendly material. The issue of connecting materials of high but possibly mismatching performance is addressed, following an increasing trend for composite structures where materials savings and optimal performance are searched in every component. The test program was aimed to identifying major critical aspects of feasibility, and giving a first estimate of safety margins and validity of the design process and assumptions. Under the first loading configuration, deriving from live traffic loads, transverse and local bending of the UHPFRC slab were emphasized. The second loading configuration corresponded to pure global longitudinal bending, the bearing capacity was checked up to the theoretical ULS loading and then up to experimental failure. Critical mechanisms and safety factors were identified. Feasibility of the concept is ensured, but some aspects should be further optimised for obtaining higher ductility and safer failure process.

### **11.4.1 THE INNOVATIVE BRIDGE DESIGN**

The present research fits within a program focused on short span bridges and in particular small industrial light structures easy to assemble on site, and likely to be used alone for smallest spans (typically 10 m-spans over a 2 lane-road) or themselves supported by structural elements, when used transversally, for most important spans. This comes from the prospective vision developed in NR2C project, concerning trends and wishes relative to bridge construction in the next decades. The main idea of the designs studied within the Work Package 3 of NR2C is to combine new attractive materials, using the best performances of each one, including the possible use of a traditional material such as wood, due to its attractive properties regarding lightness and environment.

#### **The composite UHPFRC – carbon fibres – timber concept**

The element of bridge deck considered here (Fig. 1) is formed by wooden beams, a top slab made of ultra-high performance fibre-reinforced concrete (UHPFRC), and fibre-reinforced polymer (FRP) at the bottom of the timber beams. This concept derives from preliminary design considerations developed by (Delfino, 2006). The objective was to study a very innovative structure, taking into account possibilities offered by new materials and also wood, for which advantages in terms of sustainability give a renewed interest. Among considered cross-section solutions, multi-girder type turned out as attractive in terms of global stiffness and materials savings. The multi-composite concept raises the problem of assemblies: assemblies of FRP with wood, assemblies of wooden beams with concrete slabs, and above all, the problem of the choice of the assemblies type and execution mode. The behaviour of assemblies is critically related to the transfer of forces from a material to the other one. It has a direct influence on the global behaviour of the structure composed by these materials, and on the way it shall be modelled.

Important preliminary researches were carried out for assessing the respective advantages and drawbacks of different types of connection, especially between wooden members and concrete, and their influence on the design issues of composite structures (Son Phan & Le Roy, 2006 – Son Phan *et al.*, 2007). These advances were used in the present project for giving confidence in the feasibility of mainly adhesive connections. However, due to the lack of quantified evidence on real-sized structures,

the innovative design needed an experimental validation using a laboratory test on a realistic-size structural element. This 10 m-span structural element, 2.5 m-wide for the sake of convenience, has been studied and designed by JMI, Greisch, LCPC and LCPC-LAMI and has been constructed and tested by the LCPC. Noticeably, it has been chosen to cast the top UHPFRC slab in 4 pre-cast elements, and realize the assemblies at large-scale for confirming the feasibility of the solution and detect possible difficulties.

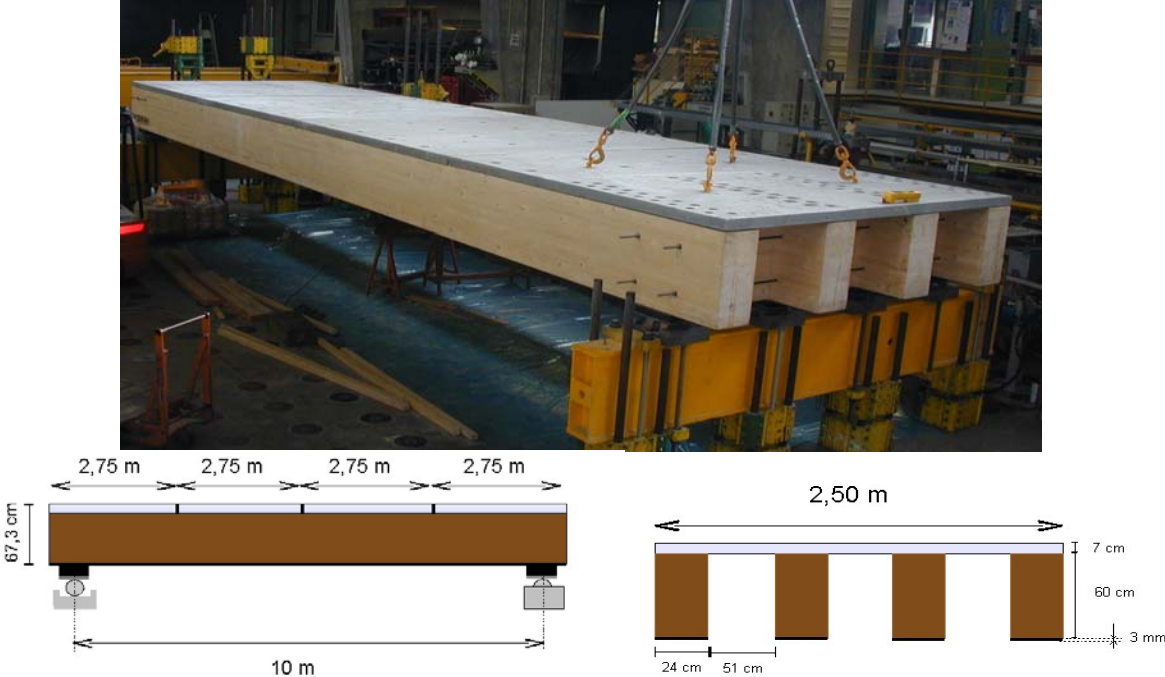

Figure 1 : The 10 m-span bridge model

**Design situations**

Design hypotheses mainly relied on existing codes (NF EN 1991-2, EN 1995-1-1) complemented by recommendations for UHPFRC (AFGC, 2002) and FRP (AFGC, 2003). Material properties used for the design are summarized in Table 1.

Property	Unit	UHPFRC	Timber (Glulam 28)	FRP
Long. Young’s modulus	MPa	50,000	12,500	110,000
Design comp. Strength	MPa	150	28	
Other design strengths	MPa	20 (bending tensile strength)	2,9 (shear)	1,500
Specific gravity	kg/m <sup>3</sup>	2,700	460	(negl.)
Safety factor (ULS)		1.3	1.3	1.4

Table 1 – Material properties used for the design

A first design situation considers local and transverse bending. This loading case appears as critical for the UHPFRC slab. Four localized loads applied in-between the beams represent two axes of a heavy weight vehicle. According to EN 1991-2 the traffic load to be considered for serviceability limit state (SLS) verification corresponds to 150 kN on each 0.4 m x 0.4 m spot, the load is assumed as equally distributed which is represented by rigid repartition plates. In Fig. 2 this situation is represented applied on the model. The loads are applied 0.75 m apart from the mid-span section, and their transverse distance is 1.5 m, which corresponds to the most severe situation relatively to the timber beams position. The simplified computation uses plate elements for representing the UHPFRC slab, simply supported on the timber beams assumed as rigid. Under the characteristic load (150 kN) the estimated transverse bending tensile stress within UHPFRC reaches 11.8 MPa.



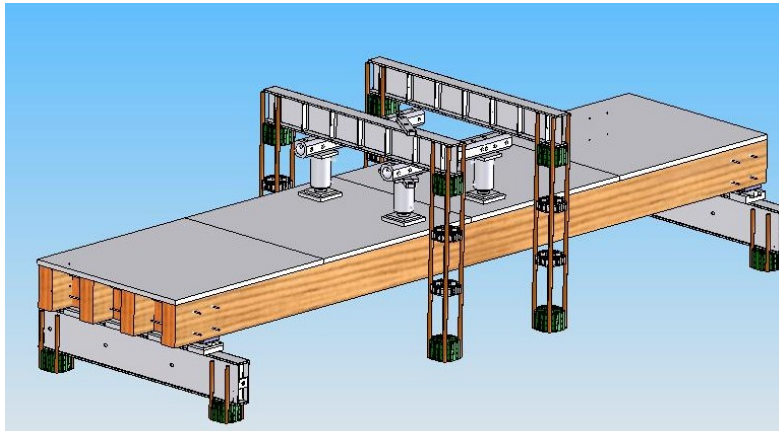

Figure 2 : Loading configuration for local and transverse design verified at SLS

A second critical design situation considers the global longitudinal bending of the model under a combination of dead and live loads. The transverse load location is no more considered. The design loads relative to ULS correspond to two times 500 kN applied at 0.75 m from the mid-span cross-section, longitudinally. By applying progressively the loads in the actuators according to this configuration, the global bending behaviour of the model can be characterized, and the satisfactory connection of the components is to be verified. This loading scheme is represented on Fig. 3. For verification of the critical design mechanisms and safety of the design procedure, the experiment shall make it possible to reach the failure of the model in a progressive increase of the loads. Assuming perfect bond between the materials, failure of the composite section is first reached by excessive tensile strength within the timber lower chord. The GL 28 timber 28 MPa design strength (ultimate strain close to 2.2 ‰) is reached for a 144 kN-global load.

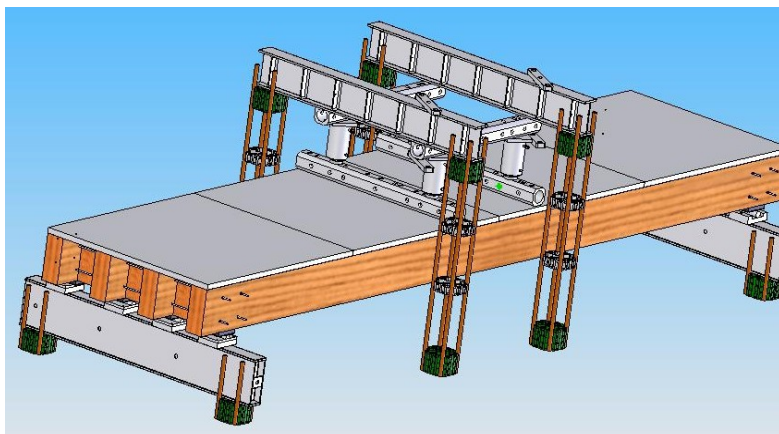

Figure 3 : Load configuration for global longitudinal design verification at ULS

#### 11.4.2 DETAILING AND MANUFACTURING OF THE MODEL

The model to be tested is made of four braced timber girders, the crossbeams being at the ends upon supports ; these wooden girders are reinforced at bottom by layers of carbon fibre-reinforced polymer, and connected to a UHPFRC top deck made of four pre-cast slabs.

##### Timber beams

Wood of the beams employed for realization of the model has been treated and stabilized with respect to moisture. It is composed of reconstituted elements. This combines wood with polymers which is a drawback for easy recycling of the elements, however the mechanical stability of the properties is better controlled. The 4 beams, 11 m-long and elements for the crossbeams are made of Glulam

GL28, with a rectangular cross-section 24 cm-wide, 60 cm-high. The height is determined by flexural and shear capacity, and the width is related to dimensions available on the market. The beams were prefabricated in a French factory, transported to another factory for application of the FRP layers, then brought to the laboratory, in a relatively dry atmosphere (40 % RH on average). Companion tests have led to longitudinal Young's modulus values comprised between 10.2 and 11.2 GPa (10.8 GPa on average), and shear modulus values about 560 MPa, significantly lower than conventionally used design values. The wooden beams were assembled including fixation of crossbeam elements on the supports. This step turned out very easy and rapidly realized (Fig. 4).



Figure 4 : Assembling the wooden beams

#### CFRP reinforcement

For reinforcement of the wooden beams, among the numerous material possibilities, carbon fibre-reinforced polymer with epoxy as polymer resin was chosen. Epoxy was selected for its assumed higher durability in outside environment. The fibres choice is due to the higher mechanical properties of carbon with respect to glass. Yet due to the price difference (factor of 10) the fibres mechanical properties should be applied worthily in the design. According to the model design, the FRP layer should bring a longitudinal stiffness equal to 330 MN/m (3 mm thickness with an equivalent Young's modulus of 110 GPa). The stiffness is mainly brought by the fibres layers, however the glue in-between the layers and between FRP and the timber may modify their efficiency, which made an experimental determination useful. After preliminary tests the number of required carbon fibre sheets was fixed to 10. The average Young's modulus is about 90 GPa and observed thickness 3.6 mm.

Among other possibilities, vacuum moulding technology was chosen for the scale:1 realisation. This solution consists of a contact impregnation of carbon fibres, available in wide 1D-sheets, directly on the intrados. When the vacuum is applied (# 1 bar), the air entrapped between the fibres and the different layers of fabrics is able to escape. The assembly is then heated up to the polymerisation temperature of the epoxy resin. The vacuum exerts a pressure which allows the matrix to impregnate the carbon fibres. After cooling, the composite part obtained is perfectly impregnated, with a controlled volume fibre content. This method (sequence illustrated Fig. 5) appeared as the most versatile, cheapest and effective to implement here.



Figure 5 : Application of the CFRP reinforcement

### UHPFRC slabs

The top of the deck consists in 4 pre-cast UHPFRC slabs, 7cm-thick, each one 2.5 m x 2.75 m, even if the tested model could have been cast in one phase only, since the real-site realization would be limited to 2.5-wide elements for truck delivery constraints. The UHPFRC mix-proportions were derived from LCPC experience, so that the UHPFRC used can be considered as close to what could be realized industrially in present conditions. Requirements consist in 150 MPa characteristic compressive strength, 15 MPa minimum bending tensile strength usable at SLS for a 7 cm-thickness.



Figure 6 : UHPFRC casting.

Slabs 1 and 2 were cast first, using two 250 l-batches for each slab with particular care for avoiding joints. Self levelling character of the concrete was confirmed (Fig. 6), only light trowelling was necessary for ensuring a correct surface. Due to low temperature during setting, inserts removal could only be done the fourth day after casting, and formwork removal only the 5<sup>th</sup> day. A significant part of autogenous and possibly early age desiccation shrinkage had already taken place. Cracks were visible especially around the inserts (slab 1), and in-between the reservation lines (slab 2). Moreover, it was observed that fibres may have fallen within the matrix, due to the much longer as expected fresh concrete state. Fortunately the second casting phase took place under more favourable conditions. Setting was observed between 24 and 36 hours. Inserts in the reservations could be released the second day after casting. No cracks were observed on the surface, no segregation of fibres was visible at the edge of reservation holes. Mechanical control of the UHPFRC properties just meets the requirements, with an average equivalent tensile strength under 4 point bending, at 5 months of age, equal to 19 to 26 MPa depending on the batches.

### Beams-slabs connection

Adhesive mode of connection between timber and UHPFRC was chosen after preliminary tests. Mechanical performance and easy application turned out preferable with a two-component epoxy resin without solvent. Unexpected from the small-scale tests was the geometrical distance (up to 19 mm) to be filled between the slabs and the timber beams, due both to geometrical imperfections of the beams and to the effect of differential shrinkage. The reservations, imperfections of curing, and possibly the segregation may have favoured increased shrinkage of the top side of the slabs, leading to corners uplift. This forced to previously apply an additional intermediate filling, also with an epoxy resin basis to favour gluing compatibility, including fine sand as a filler material. This (2-days long) gluing sequence is illustrated Fig. 7. Safety considerations for avoiding brittle delamination at the ends where maximum shear is to be feared led to an important number of long screws, especially at the ends of the slab, so that relative slipping of the slab with respect to the beams is prevented up to the design ultimate load, taking into account the limitations of the force taken by each screw. The screws heads are supposed to sustain on the UHPFRC slab itself, which gives a complicated two-steps cylindrical shape for each hole and requires a time-consuming UHPFRC filling of the holes. Detail of the joint in-between the slab elements (also filled with the epoxy resin) also deserved important design efforts, so that it can be assumed to transmit compressive and shear forces (Fig. 8).



Figure 7 : Glue application on the beams and the slabs after surface preparation (rubbing down)



Figure 8 : Details. Left : filled reservations over the long screws.  
Right : joint between slabs (after sawing of the model)

### Lessons concerning the practical feasibility

At this step, the detailed design of a 10 m-span bridge has been completed and faced to practical application, realization of a model at a realistic scale has raised some important issues. These conclusions may be temporary only, relatively to the – still partial - industrial development of the materials used. They may also indicate optimization directions for the future, for taking a better benefit of the solution.

- UHPFRC may be rather sensitive during the mixing and casting phases, due to temperature influence on the admixtures efficiency. Mix-proportioning extrapolations must be done very carefully, and checked on the real-size mixing devices, so that the consistency of the fresh concrete can be controlled and possible segregation avoided. This optimization will normally be done for an industrial process, which still enforces the desirable application of such materials in a high-quality controlled mixing, casting and curing environment. The important early age shrinkage also has to be addressed for form removal appropriate definition.
- The theoretically optimized gluing of concrete (possibly HPC or UHPFRC) on the timber beams, with a single epoxy product, requires perfect geometrical compatibility (less than 3 mm relative roughness). This seems hardly achievable at the scale of a bridge deck even using industrial timber products and pre-cast concrete elements. Thus the applied procedure (levelling using an epoxy mortar, than gluing) appears as mandatory. Provided skilled teams are employed and operations are done carefully, which both appear necessary, the total time may not be prohibitive.
- Control of the horizontal thickness of the joint between slab segments is hardly feasible. This resulted in 3 to 8 mm-thick joints and difficult control of the possibly unfilled zones. This problem could be partly solved with a simpler shape of the slab ends, so that the continuity between segments can be better ensured and entrapped voids eliminated.
- Drying cracks have been observed on the timber surface, probably related to the dry storage atmosphere. Wood sensitivity to moisture variations must be carefully addressed in real industrial processes, especially during the transient fabrication – storage – assembly phases. Beside this drawback, one must underline the easy assembly of timber elements.
- During the CFRP application to the timber surface, controlling the resin quantity and the pump pressure in order to ensure a high vacuum level must be carefully carried out. Even with the

thorough procedures applied here, delamination has been observed (see below) between carbon fibre layers due to insufficient impregnation. With this respect, some preventive advice should be enforced. A rigorous visual inspection has first to be conducted, during the polymerisation and after the curing ; then, additional control shall be carried out : for instance, infrared sensors, acoustic emission permit to detect macro defects and internal flaws between layers. It could lead to a serious improvement of the method.

- Reservation holes for the long screws caused a lot of drawbacks : complicated formwork, expensive inserts to be provided, increased UHPFRC shrinkage, time-sensitive insert removal, difficult filling with the same material as the slabs... They can be at the origin of a lot of defects and expenses. However they undoubtedly add a safety margin to the adhesive connection. Further optimization of this problem is certainly to be searched.

### 11.4.3 TESTING THE STRUCTURAL BEHAVIOUR

The critical structural tests accounted for in the design were realized on the model at an age of about 5 months for the UHPFRC slabs. Instrumentation, including load and displacement sensors, strain gauges and extensometers, plus a vibration-based monitoring, was determined in order to quantify the experimental structural response and validate the estimations of the design justification.

#### Transverse and local bending

During a first loading phase denoted as “SLS” transverse and local bending were studied, yet the domain of irreversible strains should not be reached, in order not to modify further analysis of the global bending. The deck was loaded in its central part by four concentrated loads at a square’s corner, applied on 0.4 m x 0.4 plates, 1.5 m-distant from each other in both directions, Fig. 9. Four similar 1100 kN-capacity actuators with a common hydraulic control were used therefore. For repartition purpose due to the UHPFRC slab roughness, the steel plates were laying on rubber plates.



Figure 9 : First loading phase configuration

The load was slowly applied and monotonically increased up to 4 x 130 kN after three unloading-reloading cycles. Even though the characteristic SLS loading should have been 150 kN, this maximum value of 130 kN per actuator (i.e. a total load of 520 kN) was kept in order to avoid excessive irreversible strains in critical UHPFRC zones below the loaded plates. The curves in Fig. 10 show the evolution of the maximum vertical displacements, measured at mid span of the UHPFRC slab. Deflection of the slab at transverse mid-span is also about 3 % lower than just below the loaded zones which corresponds to the slab counterflexure. The difference between the central beams deflection and the vertical deflection under loaded zones corresponds to the UHPFRC slab local bending, which is rather limited (less than 1 mm for about 500 mm clear span between beam edges). Local compliance evaluations indicate that the global structural behaviour of the model has been kept reversible during this testing phase. The maximal deflection (18.5 mm / 10,000 mm) is about 1/540 which is generally admissible for serviceability limit states.

Analysing extensions in the critical transverse cross-sections, slight irreversibility is noticed and some local crack openings at inserts edges are suspected. In upper side locations the maximum tensile stress (9.9 MPa) estimated from measured strains has slightly overcome the limit of elasticity. The average extension below the loaded zones of UHPFRC slab corresponds to an elastic strain equal to 22.8 MPa. Even if lower than the average bending tensile strength in 3-point loading identified on companion prisms, it clearly goes beyond the limit of elasticity. This stress value is significantly higher than the one estimated in the design computation, relying on simplified hypotheses. However, it is consistent with the results of an elastic 3D computation, Fig. 11. It is thus important to take into account the proper beams flexibility in the estimation of the slabs bending. Due to the desire to remain in the serviceability domain during the first phase of the test, the maximal load was limited below the theoretical limit of 4 x 150 kN. Even within this limitation, vibration-based monitoring of the model carried out after this phase, was able to detect a 1 % decrease of the first three modal frequencies, which is consistent with the probable local slabs damage.

One of the main design assumptions consists in the strains compatibility between CRFP, wood and UHPFRC. This hypothesis has been checked by plotting the strains measured at different heights of the cross-sections. It has been confirmed that the strains distribution is linear vs. the height within the cross-section (Navier's assumption). Gluing has thus ensured a perfect connection between the three materials, without any initial slippage. This result is confirmed by the absence of (statistically significant) slippage measured at the end of the beams between wood and UHPFRC.

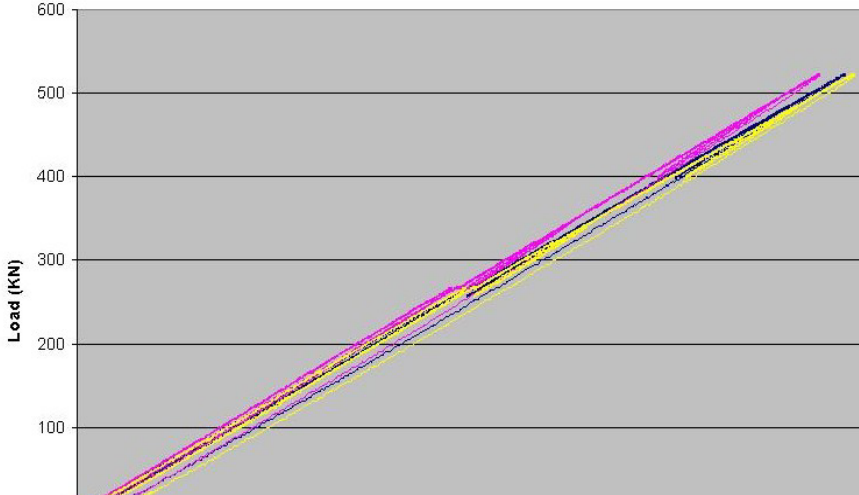

Figure 10 : Vertical displacement of the UHPFRC slab

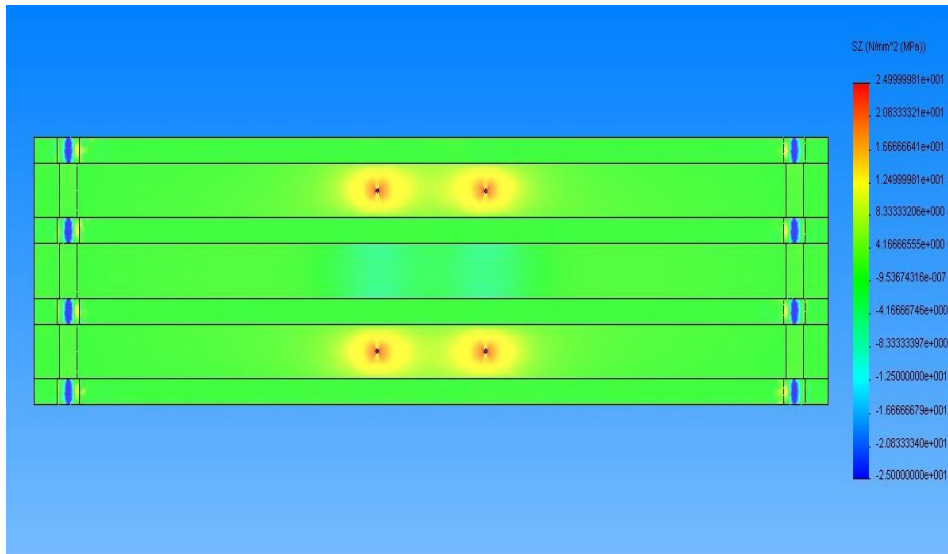

Figure 11 : 3D FE computation – lower side view.

### Longitudinal bending

The global longitudinal bending response is considered as the most representative critical situation of the innovative concept to be validated in this program. Therefore the test up to ultimate limit states (both theoretical ULS using design load values, and experimental one corresponding to structural failure of the model) were to be reached in the similar mechanical scheme of pure longitudinal bending. This scheme was realized in distributing the loads of the four actuators, previously used in the “SLS” configuration, with two 2.50 m-long very rigid transverse beams (Fig. 12), 0.71 m-apart from the mid-span. The loaded spots at about  $\frac{1}{4}$  and  $\frac{3}{4}$  of the transverse span should help realizing a uniformly distributed loading. Widespread contact was also favoured using a 10 mm-thick layer of neoprene under the beams. In this configuration, the design ULS load value corresponds to  $2 \times 500$  kN (200 kN/m over each loaded strip), that is a global load of 1,000 kN or a global longitudinal bending moment of 2,125 kN.m or 850 kN.m/m. The test consisted in applying increasing pressure through the 4 parallel-fed actuators. A first cycle was carried out up to  $4 \times 130$  kN i.e. 520 kN, the maximum load reached under the previous “SLS axle loading” configuration. Then the load was increased stepwise up to the design ULS value, namely  $4 \times 250$  kN. The model was then fully unloaded in order to make vibration-based monitoring possible, then it was loaded up to failure.



Figure 12 : Second loading phase configuration

The global structural behaviour of the model appears as quasi-linear up to 4 x 250 kN. The residual displacement after unloading reaches 0.8 mm (2 % of the 39 mm maximum displacement). It mainly derives from irreversible neoprene settlement on support. Even if some slight residual compressive strains are observed on UHPFRC at mid-span, the model behaviour appears as quasi-reversible up to the design ULS load. Experimental critical results under the 1000 kN-loading are compared with theoretically-expected values according to the initial design, and values deriving from a 3D elastic computation (Table 2). In this table, experimental stress values derive from strain measurements. Within the timber beam, the strain value at lower chord is extrapolated given the strain diagram vs. the vertical position within the cross-section (Fig. 13). According to these measures, Navier's assumption is not far from valid, even if the CFRP seems slightly overstressed.

	Experimental measures	3D FE computation	Theoretical design
Structural deflection	34.4 mm	32 mm	30.9 mm
Height of the neutral axis	425 mm	-	475 mm
Compressive stress, UHPFRC slab	38.9 MPa	32 MPa	32.2 MPa
Tensile stress, lower chord of timber beams	- 16 MPa	-16.4MPa	- 19.5 MPa
Tensile stress, CFRP	- 156.2 MPa	-158 MPa	- 173 MPa
Strain (upper side of UHPFRC slab)	708 $\mu\text{m/m}$	581.81 $\mu\text{m/m}$	644 $\mu\text{m/m}$
Strain (lower chord of timber beams)	1300 $\mu\text{m/m}$	1366.6 $\mu\text{m/m}$	1560 $\mu\text{m/m}$
Strain (CFRP)	1420 $\mu\text{m/m}$	1436.4 $\mu\text{m/m}$	1572.7 $\mu\text{m/m}$

Table 2 – Model deformation at mid-span : measures, design values and 3D elastic FE computations

The average 10 % discrepancy between measures and predictions may have several reasons. First, the average longitudinal Young's modulus of timber turned out as only 10.8 GPa instead of 12.5 GPa in the design. Secondly, the UHPFRC stress experimental estimation derives from the measure of a strain gauge glued over the joint between slabs 2 and 3, with a 20 % artefact due to the significant glue compliance. Moreover, the difference between experimental and theoretical estimates of tensile strains in CFRP and timber chords is consistent with a difference in the level of the neutral axis within the mid-span cross-section (Fig. 13). In fact, the difference of the neutral axis position may be explained by a local effect of the glue joint between the slabs, since a 20 % reduction in (apparent) compressive strains is compensated by a 20 % increase in internal level arm within the cross-section. Conversely, the level of the neutral axis is similar in design and in the experiment for the cross-section located at 1.5 m from the support (Fig. 14). Given the quasi-linear strain distribution with respect to the height within the cross-section, it is noticeable that the adhesive connection between timber beams and UHPFRC slabs is still fully satisfactory at this stage.

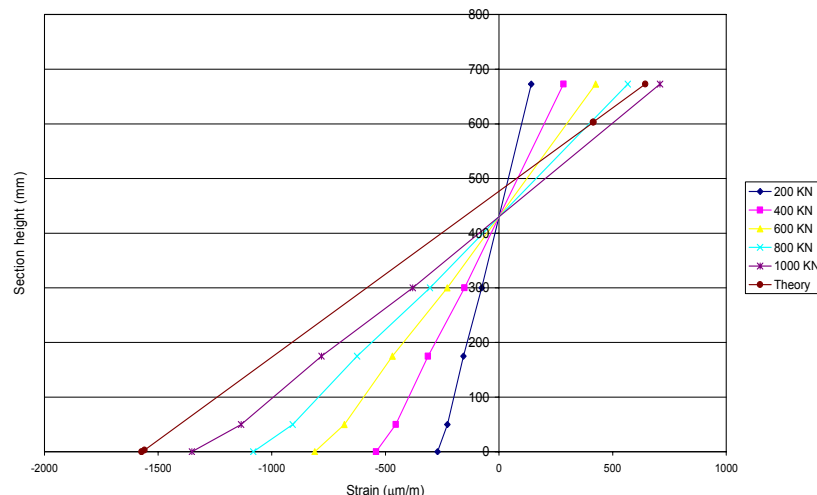

Figure 13 : Strains at mid-span along the cross-section height. Verification of Navier's assumption

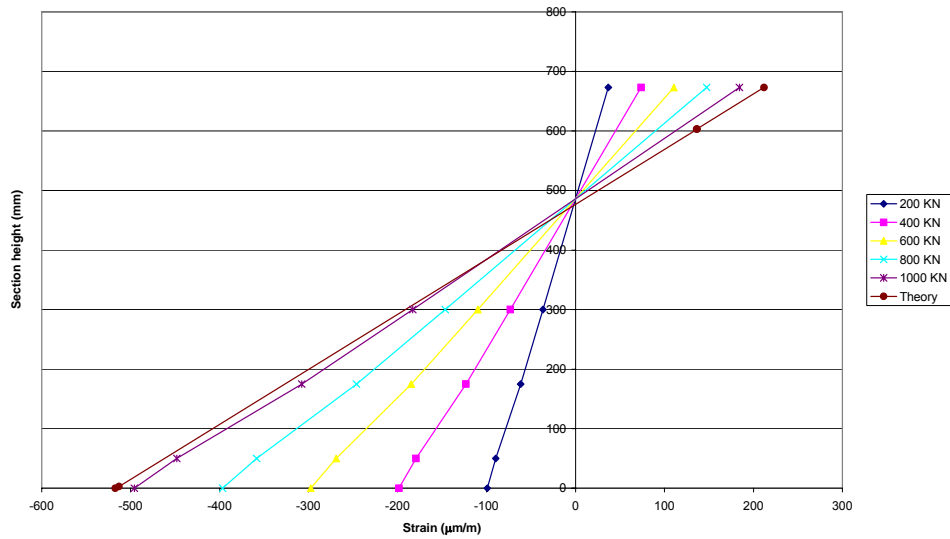

Figure 14 : Strains and position of the neutral axis, 1.5 m apart from the support.

Since no irreversible phenomenon was observed in the “pure longitudinal bending” configuration up to the theoretical ULS level, it turned out necessary to increase the applied load, in order to identify the critical non-linear and failure mechanism(s) and quantify the design safety margin with respect to them. The first irreversible phenomenon was observed along the joint between slabs 2 and 3. Non-linearity (see UHPFRC longitudinal strain on Fig. 15) occurs beyond 1200 kN and failure of the joint at 1328 kN. Failure first occurred on the side of P4 beam, since the joint width on this side was higher. Then cracking propagated along the joint. Visually, crushing of the joint was accompanied by scabbing of the UHPFRC material on the upper side of the slab, limited to about 5 to 10 cm apart from the joint. During this process, load could keep on increasing, since the compressive limit of UHPFRC was not reached and compressive forces still could be transmitted in an upper UHPFRC hinge at mid-span. At the onset of the observed failure, the observed strain  $\Delta L/L$  equals 1300  $\mu\text{m/m}$ , which corresponds to local strains of  $\varepsilon_c = 5400 \mu\text{m/m}$ , that is about 60 MPa-stress, within the glue joint. This stress value, especially for the thicker part of the joint where confinement effects might be insufficient, appears as close to the nominal crushing strength of the epoxy resin. These orders of magnitude have been confirmed by a 3D F.E. computation, taking explicitly the joint reduced stiffness into account. *Post mortem* analysis of the model, including longitudinal sawing between P2 and P3 beams, helped confirming the limited extent of the joint failure, with UHPFRC scabbing on top side (Fig. 16). The joint geometrical detailing and the principle of gluing the slabs yet requires further optimisation.

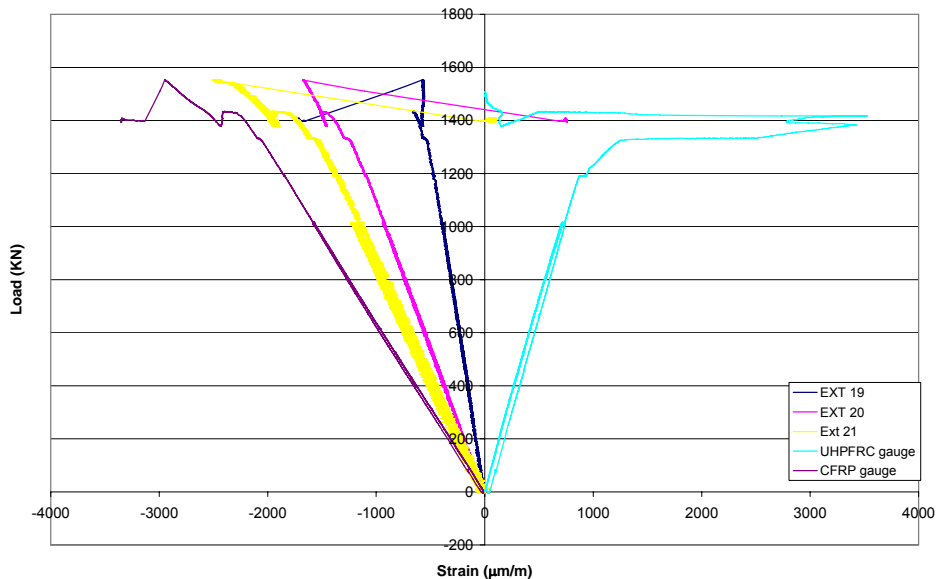

Figure 15 : Strains within the mid-span cross-section (verification of Navier’s assumption)



Figure 16 : Failure of the cold joint (*post mortem* sawn cross-section)

The local joint failure at 1328 kN appears as the first sign of non linear global behaviour, considering the global load – mid-span deflection curve measured below the 4 beams of the model (Fig. 17). The visible sudden increase in deflection (point “A”) is mostly noticeable for beam P4, as explained by the larger joint width on this side. On this same figure a second major event can be noticed, namely at 1550 kN which corresponds to the maximum global load sustained by the model. At this load level, an intense acoustic emission was noticed, related to tensile cracking of beam P2 within the timber part. Vertical cracks were visible in the central constant-bending moment zone (Fig. 18), over about 30 to 40 cm (namely the whole zone supposed to be under tension as indicated Fig. 13). This failure mode corresponding to excessive tensile stresses within timber, correspond to the most probably occurring failure according to the design. Complementary analysis of the longitudinal strains within P2 cross-section at mid-span indicate an ultimate extension at failure equal to about 2600  $\mu\text{m}/\text{m}$  in the bottom wooden chord, and about 2800  $\mu\text{m}/\text{m}$  in the outer CFRP layer. While the carbon resistance is far from being reached, the observed ultimate wood extension is consistent with the Glulam design strength (28 MPa), yet without any safety factor, given the experimental Young’s modulus equal to 10.9 GPa.

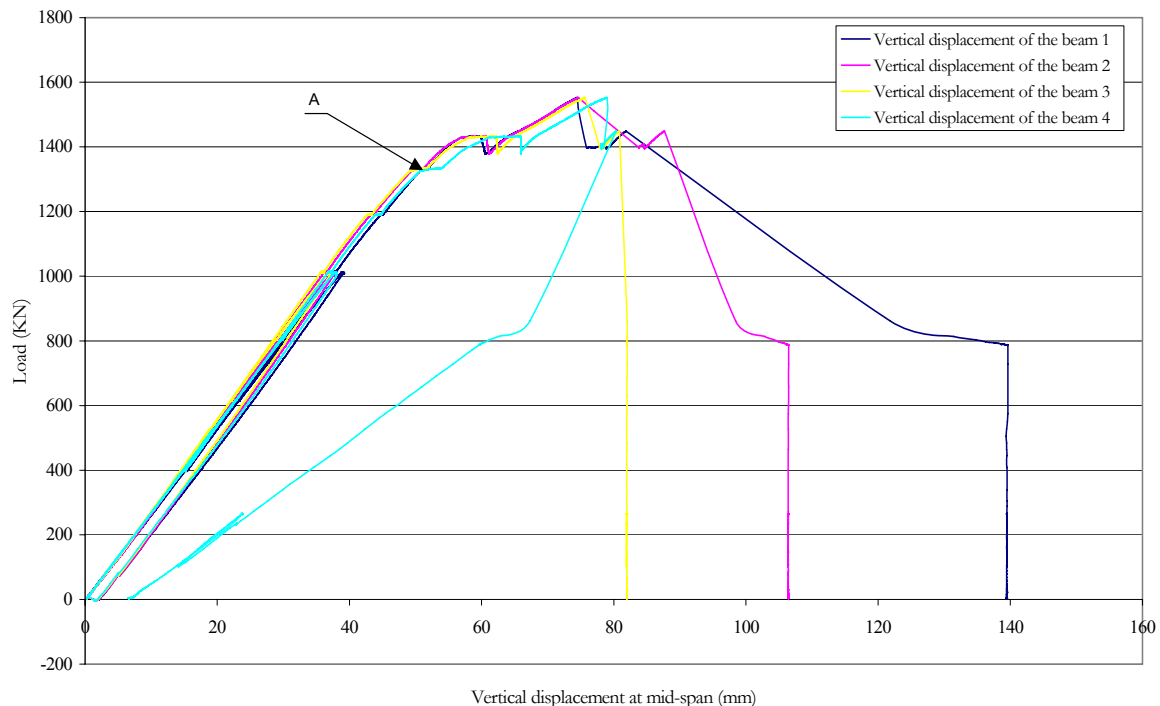

Figure 17 : Vertical displacement at mid-span for the four beams.



Figure 18 : Tensile (vertical) cracking in the mid-span zone for beam P2



Figure 19 : Delamination between CFRP layers below beam P2 mid-span.

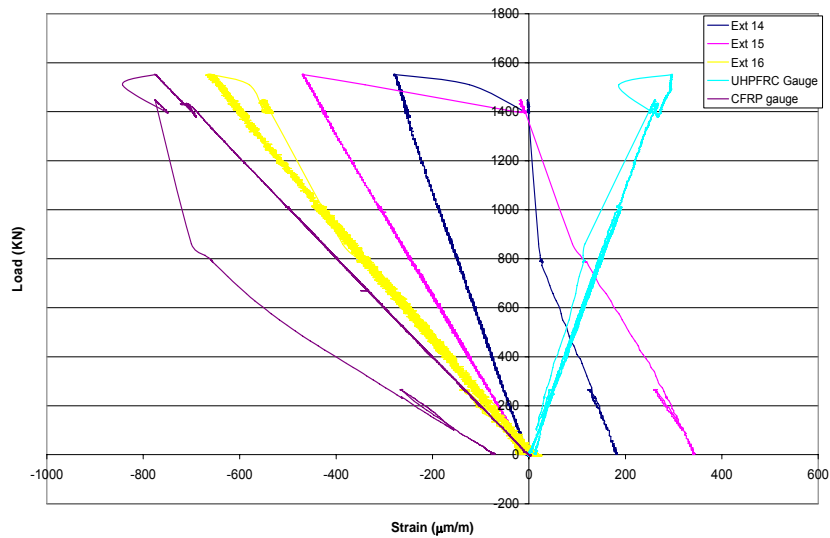

Figure 20: Strains within the cross-section 2 m-apart from the support (Navier's diagram)



Figure 21 : Tensile cracking and propagation within timber, P2 beam (after *post-mortem* sawing)

In the central zone the vertical cracks did not reach the beam lower chord, which can be interpreted as a sign of CFRP efficiency. However, the cracks initiated vertically have propagated horizontally parallel to the wood fibres, down to the CFRP-timber interface. *Post mortem* analysis, as well as thorough consideration of Fig. 15, has brought important additional information. During sawing of the central part, CFRP below beam P2 was found as no more efficiently glued. It appeared clearly that an internal delamination was created between the last layer (the one bonded on the wood) and the set of the others (Fig. 19). This process may have occurred from 1430 kN, where the CFRP strain increased more rapidly with respect to the load in the P2 mid-span section, while CFRP anchoring remains active (validity of Navier's assumption) closer to the ends (Fig. 20). In fact, even though CFRP tends to re-anchor wide apart from mid-span, the mismatch of longitudinal strains between cracking wood fibres and elastic remaining CFRP concentrates shear along the interfaces parallel to timber fibres, leading to uncontrolled and brittle horizontal crack propagation (Fig. 21). For a possible ductility improvement, CFRP should have been positioned vertically in order to withstand horizontal crack propagation.

Failure of the beam P2 resulted in a sudden increase of its deflection and load release. The vertical displacement at mid-span reached about 10 mm more than at the onset of failure at 1550 kN, while the load had decreased down to about 1400 kN (Fig. 17). Redundancy of the model limited a too sudden increase in deflection, and decrease of the applied loading : since the actuators control parameter was related to a common upstream jack displacement, and not to force or pressure, a further equilibrium could be reached successfully after beam P2 failure. However symmetry of the forces taken by each beam was no more ensured. This situation has led to the third and last irreversible event, consisting in tensile cracking of the timber within P1 beam, followed by sudden and unstable horizontal crack propagation until the supports (Fig. 22). This last failure was reached for a total load of 1450 kN. Further loading of the model was no more possible. Contrarily to beam P2, this failure seems not to have been favoured by CFRP insufficient bond. However, due to the intense energy release (and CFRP elastic trend to recover initial state) arrest of horizontal crack propagation within the weak direction of timber turned out impossible, either even on support or on mechanical timber nodes. Failure thus again occurred within timber and propagated in-between fibres (weak direction) even with adhesive and unbroken CFRP reinforcement. Glue efficiency in fact did not fail. However horizontal longitudinal strains mismatch is patent especially at the end (slippage, Fig. 22). During this last event, the applied load suddenly decreased from 1450 kN to about 800 kN, and P1 vertical displacement at centre suddenly increased from about 70 to 140 mm. After failure of the second beam, which even took place for a reduced global load, redundancy of the structure has turned out as fully consumed. Given such a brittle event, the safety margin relative to ultimate load (1450 to 1550 kN as compared to 1000 kN design ULS load) appears as hardly sufficient.



Figure 22 : Final failure, tensile cracking and propagation within timber, P1 beam.

#### 11.4.4 CONCLUSIONS

The detailed design and large scale validation of a prototype 10 m-span composite UHPFRC – carbon fibres - timber bridge helps drawing conclusions concerning the feasibility of the sandwich concept developed, the critical issues to be considered in practical realization, and also the validity of the preliminary design hypotheses and detailing assumptions. These conclusions are listed hereafter.

- Material properties and design rules of UHPFRC and composites tend to get satisfactory mature understanding for design. On the contrary, the behaviour of the lightweight material (wood in the present sandwich concept) used for shear transmission, even though critical in the design, seems to be less controlled. Possible defects may significantly change the safety margin. In the present case the characteristic design values of GL28 have just been reached. Timber properties should thus deserve increased research and control efforts.
- Connection of UHPFRC pre-cast elements one against the other should deserve special attention, especially for thin elements. Stress concentrations and premature cracking may be caused by geometrical uncertainties and imperfect joint (or gluing) execution. Robustness should be searched which implies efforts on UHPFRC mix-design (control of shrinkage), geometrical details, control of tolerances, anticipation of field conditions of application, etc.
- Adhesive connection seems promising and ensures composite behaviour in the serviceability domain, which provides easily understandable linear behaviour and helps sound calculations. Effective application either in the factory for the wood-composite gluing or on-site for the wood-UHPFRC connection, shall take geometrical tolerances into account, which may require additional gluing layers and technically sensitive, time-consuming and specialized workmanship-requiring procedures to be developed. Possible flaws should be limited, and when remaining, detected and corrected, which relies on validated control procedures. Moreover, failure of this connection, which may be controlled by hardly detectable execution flaws, may result in very brittle structural failure. This implies an additional connecting system only for safety purpose, which may result in significant additional expense.
- Due to the orthotropic behaviour of wood, parallel reinforcement using (also orthotropic) composites does not prevent brittleness versus cracks propagating in-between the fibres. A kind of shear reinforcement (transversely to wood fibres) might be of interest for ensuring the desired non-brittleness.
- Simplified execution and material savings were searched in the tested multi-beam solution. However the beams redundancy did not result in high enough ductility, in the sense that the bearing capacity at first failure was hardly recovered when further loading the remaining beams. Possible advantage of cross-beams towards this end might be questioned.

- Due to the deformability of wood and thin UHPFRC plates, appropriate prediction of stresses for design verifications of the considered innovative bridge deck shall be carried out without oversimplified assumptions concerning the relative deformability of the different components of the structure, and accounting for the 3D modes of deformation.

### Acknowledgements

The writers are pleased to thank the LCPC technicians, especially from the Structures Laboratory, who helped in the whole experiment ; they gratefully acknowledge the help of ENPC-LAMI partners for the preliminary tests concerning adhesive connections between wooden and concrete parts, for their contribution regarding the choice of wood and CFRP components, characterization, selection and control of the adhesive connection.

The project is indebted to Y. Gicquel and colleagues from Sika Corporation for their participation in realizing the glued connections between wooden beams and the UHPFRC slabs. Finally, the design of the model derives from a collective engineering process within WP3 team, especially including participations of LCPC (T. Kretz, B. Godart, F. Toutlemonde, B. Mahut), JMI (J.-M. Tanis), ENPC-LAMI (R. Le Roy, J.-F. Caron) and Greisch (F. Gens), yet this project would not have been realized without the contribution of F. Gens from bureau d'études Greisch, who carried out the design justifications and took in charge drawings of the model.

### REFERENCES

- EN 1995-1-1, (2002) Eurocode 5, Conception et calcul des structures en bois.
- AFGC (2002) "Bétons fibres à ultra-hautes performances", recommandations provisoires, documents scientifiques et techniques, Association Française de Génie Civil.
- AFGC (2003) "Réparation et renforcement des structures en béton au moyen des matériaux composites", recommandations provisoires, documents scientifiques et techniques, Association Française de Génie Civil.
- NF EN 1991-2, (2004) Eurocode 1 – Partie 2, Actions sur les ponts, dues au trafic.
- Delfino R. (2006) "Conception d'un pont en matériaux composites de faible portée", Projet de fin d'études à l'Ecole Nationale des Ponts et Chaussées.
- Son Phan H. et al. (2007) « Nouveaux tabliers composites Bois-BHP- Carbone pour les ouvrages d'art », GC'2007, AFGC, Paris, 21-22 Mars.
- Son Phan H. and Le Roy R. (2006) « Ponts mixtes Bois-Bétons–Etude des systèmes de connexion », Journées des Sciences de l'Ingénieur, Marne-la-Vallée, 5-6 Décembre.

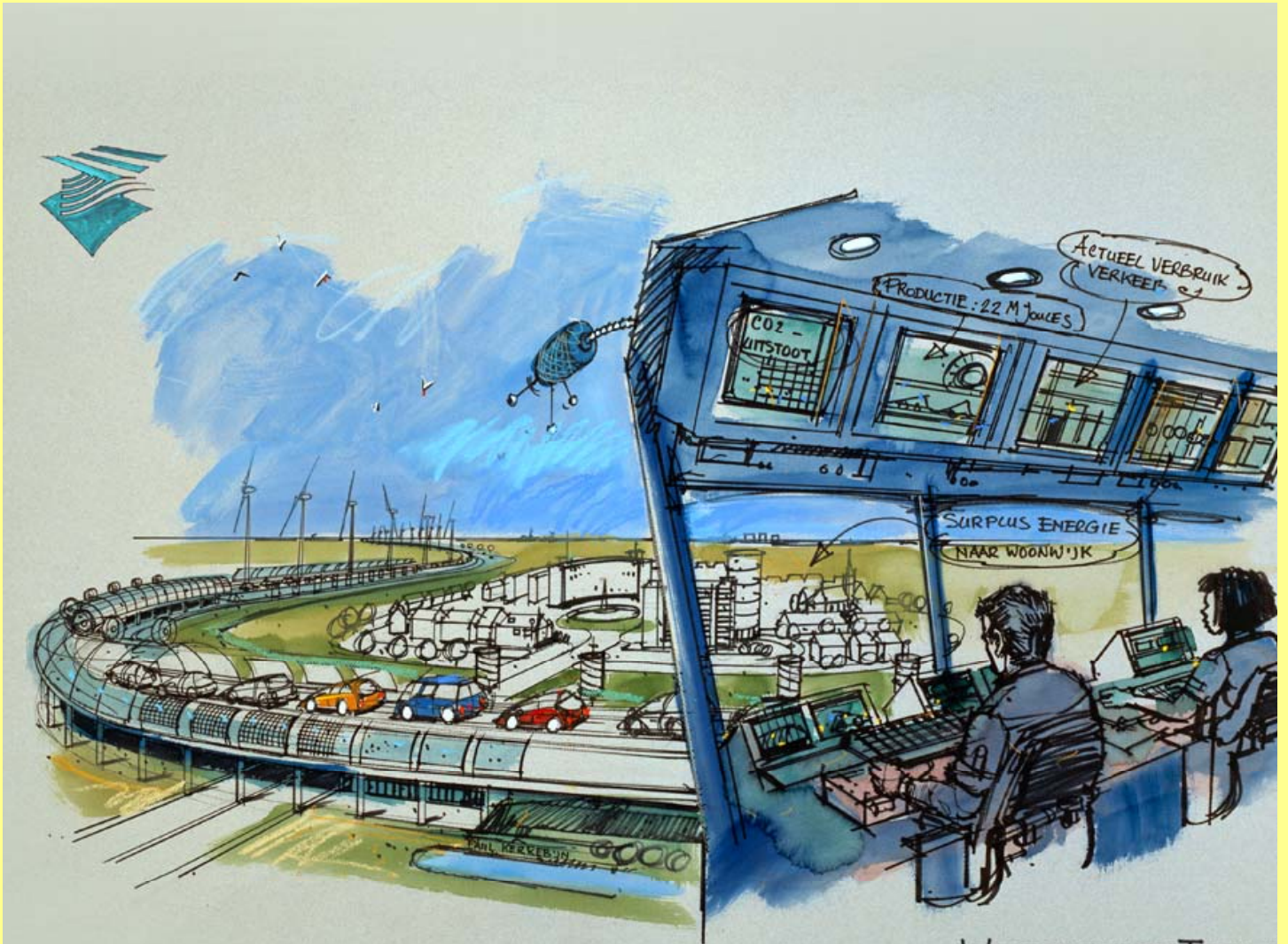



# 12 | Towards safer infrastructure

## 12.1 Roadway perception technology using the infrared know-how

Jean DUMOULIN (Laboratoire Central des Ponts et Chaussées LCPC – France)  
Mario MARCHETTI (Laboratoire Régional des Ponts et Chaussées LRPC de Nancy – France)  
Vincent BOUCHER (Laboratoire Régional des Ponts et Chaussées LRPC d’Angers – France)  
Louisette WENDLING (Laboratoire Régional des Ponts et Chaussées LRPC d’Autun – France)  
Michèle COLOMB (Laboratoire Régional des Ponts et Chaussées LRPC de Clermont-Ferrand – France)

### Summary

This project aims to address elements of interurban roads that can be modified to turn them more cooperative for on board automotive infrared vision systems. It mixes an experimental approach on real sites and in fog tunnel, infrared emissivity measurements with a dedicated apparatus developed for pavement surface characterization and simplified numerical simulation of road scene and attenuation by fog according to the size of water droplets distribution. Comparisons between experiments and simulations are done. Experiments on road site and in fog tunnel allowed us to validate numerical simulations. Numerical simulation tools developed permit to evaluate the size of cooperative elements of infrastructure required to be perceptible on infrared images by taking account the characteristics of on-board infrared vision system used. Nevertheless, experiments have also permitted to verify that improving contrast on infrared images by generating a thermal excitation on infrastructure typical elements had to be favour in front of reducing their emissivity in foggy night conditions. Finally, recovering energy from road could be a sustainable solution to generate active thermal elements for on board infrared vision system.

### 12.1.1 INTRODUCTION

Nowadays, the progress made out in the field of on board electronics and sensors (computer, camera, etc...) favours the emergence of assistance systems for driving road perception. Research works undergone in the field of image processing applied to stereoscopic image acquired on board of a vehicle allow obstacle detection. Furthermore, recent research works lead to the possibility of computing a visibility distance under foggy conditions, by using a simplified extinction light model coupled to a specific image processing algorithm. Nonetheless, the efficiency of these works depends on the information available inside the image and they are all based on the use of imaging system in the visible spectrum. As an example, to spread out in night conditions distance visibility computing and obstacle detection, you’d have to take into account how the vehicle can light up the roadway assuming that no bad weather conditions will be encountered. Traffic condition at night (lighting interference) and weather forecast at night or in daylight (rain, fog, snow, sunny nightfall on wet pavement) do not favour part of these methods based on the use of the visible spectrum.

So, even if overhang in research are observed as well in the field of on board sensors as on the road vision perception models under more or less favourable weather conditions, there remains an investigation field, which to our knowledge was poorly examined, to increase the efficiency of the roadway perception device. It’s the potential of the infrared spectrum. In this field, one will note the appearance of vehicles (top-of-the-range) marketed with infrared vision device. But, in situ performances of such systems remain dependent on the intrinsic and extrinsic properties of the road. Results available in literature are frequently presented with a qualitative analysis made on infrared images after treatment. First results are available with active infrared systems (infrared system

coupled with vehicle headlights), but results analysis still remain a qualitative analysis of the image produced. To our knowledge, no investigation on the properties of the road infrastructure in the infrared spectrum has been published. So this aspect in the infrared vision for automotive application has to be investigated to see if the performance of such vision system could be enhance by acting on the infrastructure.

The innovation developed in the present work package focuses on the study of the pavement and road sign thermo-optics properties in the infrared spectrum applied to road perception under various weather conditions (restricted to fog). To reach this aim, measurement methods to characterise, in the infrared spectrum, used materials or new participative ones (spectral and directional thermo optics properties) were examined, taking into account the fact that road perception will be made by on board infrared vision device. A simplified transmission model was developed and used to evaluate the enhancement of performance that could be reached with on board infrared vision by acting on the infrastructure. Few tests were done to compare simulation with experimental results on real test site and in laboratory. These works leaned on the experience of LCPC and its partners (LRPC of Angers, Autun, Clermont-Ferrand and Nancy) in simulation and measurement experimentation available in the visible spectrum and the know-how in infrared system applied to winter time experimental pavement monitoring of some test site in France.

We can summarise the overall objectives of our research investigation in this innovation task by the following sentences:

- Enhance safety for drivers
- Acting on road infrastructure material's to turn them cooperative for on board infrared vision system
- Reducing on road trials
- Enhance knowledge in roadway perception through on board infrared vision systems in bad weather conditions and/or during night time

### 12.1.2 STATE OF THE ART

Looking at recent completed European projects on infrared vision in automotive<sup>1,2</sup>, it could be said that its use had mainly focused on the detection of animals, pedestrians and obstacles at night or under poor weather conditions with degraded visibility. For instance, published works<sup>3</sup> used fusion algorithm and image processing applied to data acquired with different on-board sensors including infrared system. To our knowledge, for standard infrared on-board detector available on the market for automotive application, pedestrian detection and shape recognition research works were developed for a set of distance to detectors ranging from 5 to 25 m. The infrared focal plane array (IRFPA) was of 320 x 240 sensitive elements (e.g., see 2) with a pitch of 45 $\mu$ m. Nonetheless, it was also shown that the use of fusion algorithm with visible spectrum images enhanced performances in the detection of pedestrians. But in those approaches, infrastructure thermo-physical properties had not been investigated to enhance the road driver visibility as, for instance, through the use of cooperative materials for on board infrared vision system. To drive the research in such a direction, investigation on infrastructure behaviour in the thermal infrared domain required the evaluation of the radiation heat balance of the whole system (i.e. the road and its environment) at different periods of the day and for different infrared-vision-system configurations. Considering what was done in the domain of teledetection, commercial tools<sup>4,5</sup> existed, but investigations on thermo-optical properties<sup>6</sup> were also mandatory due to the increase of the spatial resolution of new sensors. Software for radiation heat balance in enclosure<sup>7</sup> were also available. Nevertheless, these tools were more dedicated to heat transfer or airborne vision approaches than for infrared vision applied to automotive.

Thus, to investigate possible modifications of road infrastructure to enhance infrared vision for drivers, the research work approach developed in NR2C couples numerical simulations (in infrared and visible spectrum) with specific experiments as laboratory characterizations of road material infrared radiative properties, on roads and in fog tunnel infrastructure visibility in night conditions.

### 12.1.3 STUDY OF MEASUREMENT METHODS IN SITU FOR INFRARED PROPERTIES

The knowledge of infrared emissivity of pavements is mandatory to get a proper understanding of road weather phenomena occurring on pavement surface. This is an important parameter for thermal exchanges between pavement and atmosphere for road surface status forecast. Some models have indeed shown the relevance of emissivity on pavement surface temperature. A change of 0.92 to 0.98 could roughly induce a 1.3°C temperature change according to the CESAR/GELS model, that could have incidences in winter maintenance. This parameter is also important in thermographic techniques since emissivity allows to go from a luminosity temperature to a surface temperature. Such knowledge relied so far on literature data. Some studies aimed at the determination of physical properties of the various pavement materials in France, along with other materials used in the road infrastructure. An experimental setup has been designed<sup>8</sup> to measure the total directional emissivity in the 1-20 μm spectral band, using a 5°C-amplitude thermal modulation technique. The undertaken work has consisted in determining the experimental conditions to measure this parameter, and evaluate the influence of factors such as the thermal modulation frequency. Then some measurements were done with the experimental setup and a FLIR S65 infrared camera.

Experimental apparatus for total directional emissivity measurement (fig. C.3.1) has shown a good ability in the measurement of this parameter in the 1-20 μm spectral bandwidth. The thermal modulation frequency and the measurement duration could be adjusted to be adapted to on-site measurements. The repeatability of the measurement is correct. Measurements have been done on a large range of emissivity values, with various surface composition and roughness.

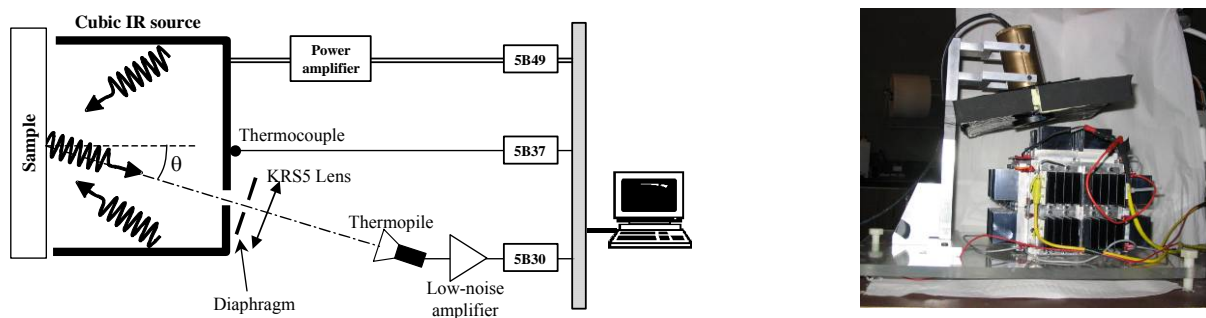

**Figure C.3.1:** Description of the experimental device (left) – Photography of the apparatus (right)

The emissivity measurement does not depend on modulation frequency, which changes the measurement duration. The greater is the frequency, the shorter is the duration. Nevertheless, the thermal inertia of the infrared source has to be considered. The greater the frequency, the shorter the available time for the infrared source to dissipate the energy accumulated during the heating phase. A shorter frequency could also affect the thermal balance of the infrared source due to its inertia, affecting the accuracy of the measurement. This could cause a temperature drift, this latest not being ambient anymore. A 12.5 mHz appeared to be a good compromise, with an acceptable measurement duration. A calculation module is included in the control of the measurement device at the end of each measurement period. Once the emissivity has reached a stable value, the measurement could be considered as completed. Measurements run on materials of road infrastructure materials (Fig. C.3.2 and Table C.3.1) have lead to values ranging around 0.95 (except steel parts which were 0.27). Complementary measurements obtained with a FLIR S65 infrared camera have given a directional emissivity of a semi-granular pavement of 0.85 within the 8-14 μm spectral band. This emissivity was stable with temperature and considered directions (15° et 75° with respect to an horizontal plane).





**Figure C.3.2:** Examples of road samples – M2 (left) and M3 (right)

Sample	Alumina	Black paint	Road sample M2	Road sample M3
$K \times (10^7 \text{ K}^4 \cdot \text{mV}^{-1})$	6.30	6.42	6.22	6.30
$\varepsilon_{\text{validation}}$	0.72	0.72	0.72	0.72
$\varepsilon_s$	$0.71 \pm 0.02$	$0.98 \pm 0.01$	$0.93 \pm 0.02$	$0.93 \pm 0.01$
$\Delta T$ (°C)	$3.69 \pm 0.04$	$3.73 \pm 0.02$	$3.69 \pm 0.02$	$3.70 \pm 0.02$



**Table C.3.1:** Measurement result examples between 1-20  $\mu\text{m}$

Roughness and surface composition could be linked to wearing of the pavement because of the traffic, in particular with semi-granular structures. Some measurements run on such a structures of increasing roughness coated with a material of known emissivity (Table C.3.2) have shown an emissivity change that could go up to 100 % with respect to a smooth surface.

Material composition	Measured emissivity	Emissivity variation (%)	$\varphi_{BT}$ (%)	$\varphi_{Al}$ (%)	Computed emissivity
black adhesive tape 	$0.95 \pm 0.01$	0	-	-	-
Al foil with black adhesive tape cross stripes 	$0.76 \pm 0.01$	19	81	19	0.76
Al foil with black adhesive tape stripes 	$0.37 \pm 0.01$	61	44	56	0.42

**Table C.3.2:** Surface composition incidence on its emissivity

Furthermore, some artificial surface composition heterogeneities have been created, and could created 60 % emissivity variation compared to homogeneous surface (Table C.3.3). A great emissivity contrast is mandatory to obtain a great emissivity variation.

material roughness	emissivity	standard deviation	emissivity variation (%)
Silver paint on a smooth surface 	0.34	0.01	0
silver paint on a smooth pavement 	0.42	0.01	22
silver paint on a rough pavement 	0.69	0.02	101

**Table C.3.3:** Roughness incidence on the emissivity

The developed measurement system and results presented in the two last tables will be useful to predict effect of modified emissivity, for instance by adding local patches on pavement surface using a reflective paint in the infrared, on to its perception through an infrared vision system. Nevertheless, the spectral bandwidth used for measurement is still too large with regards to the more restricted spectral bandwidth of infrared vision systems on the market.

### 12.1.4 STUDY OF A SIMPLIFIED MODEL FOR ATMOSPHERIC INFRARED TRANSMISSION IN FOG FOR ROAD METEOROLOGICAL CONDITIONS

A numerical model based on Mie theory<sup>9,10</sup> has been developed. It incorporated several macroscopic fog properties<sup>11</sup>: scattering, absorption, and extinction coefficients. The model was used to compute fog optical properties with experimental data (water droplet size distribution) acquired in fog tunnel. Furthermore, to reproduce basic scenes in the visible spectrum experimentally realized in a fog tunnel, simulations based on Monte-Carlo technique have been developed. Among the laws used to simulate particle size distribution, the gamma modified distribution of the droplets is the most used in fog case,

$$\frac{dN}{dr} = n(r) = ar^{(\alpha)} e^{(-br^\gamma)} \left[ cm^{-3} . \mu m^{-1} \right] \quad (1)$$

where  $n(r)$  is the number of droplets per classes of radius  $r$ , and  $a$ ,  $\alpha$ ,  $b$  are parameters used to adjust the model on to observations. A typology for two types of fog, advection (convection with moist air over a cool surface) and radiation, with parameter values could be found in Ref. 12. These parameter values are reported in Table C.3.4.

Type of fog	Model	$a$	$\alpha$	$b$	$r_m(\mu m)$	$N(cm^{-3})$
advection	1	0.027	3	0.3	10	20
	2	0.0659	3	0.375	8	20
radiation	3	2.37	6	1.5	4	100
	4	607.5	6	3	2	200

**Table C.3.4:** Parameters to perform fog water droplets size distributions

Models 1 and 2 represent heavy fog for meteorologists (Visibility = 110 m and 160 m). Although the total particle number  $N$  is low, their mode radius (10 and 8  $\mu m$ ) implies a strong scattering. Models 3 and 4 represent moderate fog conditions for the different types (Visibility = 200 and 330m), with greater particle number ( $N = 100$  and  $200 cm^{-3}$ ) but droplet size much small ( $r_m = 4$  and  $2 \mu m$ ).

However, these models do not correspond to experimental conditions in Clermont-Ferrand fog tunnel where meteorological visibility could be as low as 6 m with a higher number of particles per classes of radius  $n(r)$ . Figure C.3.3. (left) presents water droplet size distributions measured in fog tunnel for different meteorological visibility, "V".

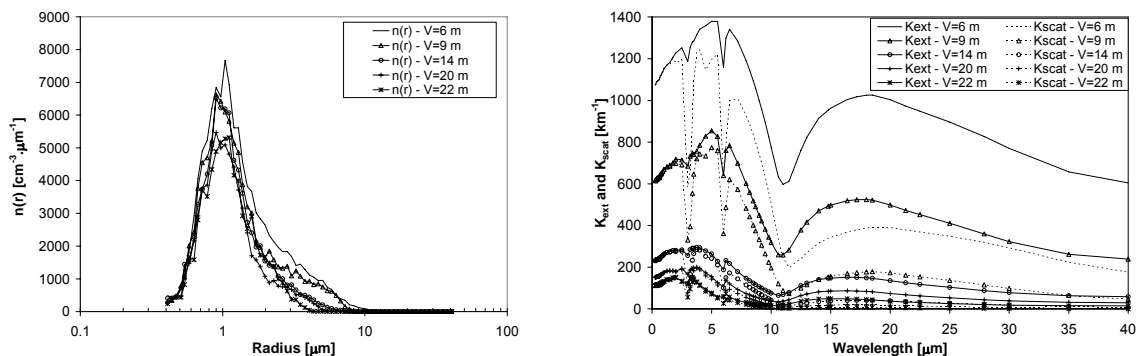

**Figure C.3.3:** Water droplet distribution measured data (left), extinction coefficients computed (right)

Measurement values have been obtained after complete saturation in water droplet in the fog tunnel and acquired at different times during fog natural dissipation. Visibilities "V" reported were measured with a transmissionmeter located in the fog tunnel. Extinction coefficient is then computed for different wavelengths using the following formula,

$$K_{ext} = 10^{-3} \int_0^{\infty} Q_{ext} \left( \frac{2\pi r}{\lambda}, m \right) \pi r^2 n(r) dr \quad [km^{-1}] \quad (2)$$

where  $Q_{ext}$  is extinction efficiency depending on wavelength  $\lambda$ , droplet radius  $r$  and refractive index of the medium  $m$  (e.g., see 13). Results obtained for different water droplet size distributions (i.e., meteorological visibility) and wavelength ranges from visible to far infrared are shown in Figure C.3.3. (right). Dashed curves represent scattering contribution for the total extinction. In visible range, extinction and scattering coefficients could be merged (absorption negligible). However, for the far infrared range absorption is no more negligible.

In the visible spectrum, scene image simulations were based on Monte-Carlo technique. The developed simulator asked to choose wavelength and fog droplet radius. From these two parameters, the phase function was calculated and scattering directions were distributed according to probability density. Influence of water droplet size of each fog type for a same meteorological visibility could then be studied. Figure C.3.4. shows simulation results for meteorological visibilities of 22 m and 30 m, with 1  $\mu\text{m}$  water droplet radius, corresponding to experimental conditions available in the fog tunnel.

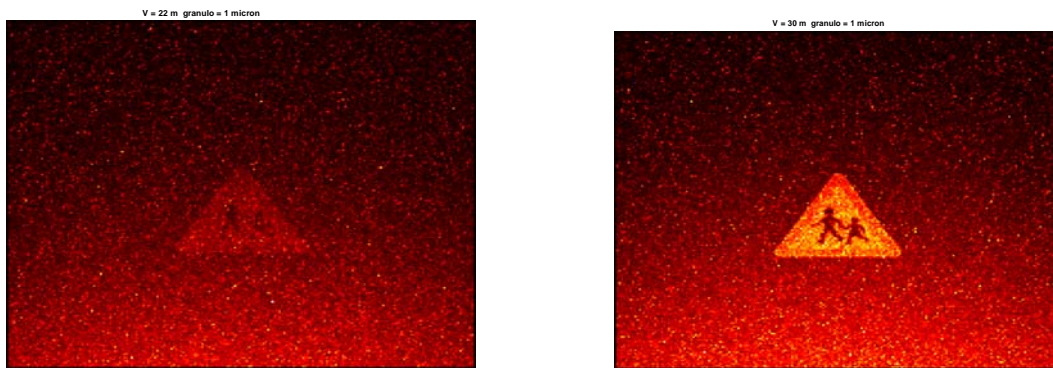

**Figure C.3.4:** Visible range simulation for a panel located at 30 m  
left image “V=22 m” – right image “V=30m”

Visual analysis of simulated images presented in Figure C.3.4 shows a rapid fall down of the contrast between road sign panel (placed at 30 m) and background of the scene.

### 12.1.5 DEVELOPMENT OF A INFRARED SIMULATION TOOL FOR SIMPLIFIED ROAD GEOMETRIES

Simulation tool developed<sup>14</sup> for simplified road geometry vision with an IRFPA incorporates three main steps to generate the incidence map that could be viewed through an infrared camera looking at the road. Nevertheless, at that stage of our development we didn't introduced a fourth step to determine thermal contrast detected by taking into account IRFPA detector technology (quantum or thermal) as proposed by G. Paez and M. K. Scholl<sup>15</sup> in their works.

The first step consisted in meshing the real world (the road and its surrounds) according to the location of the infrared camera in the scene and its internal properties. It was done by projection onto the ground, assumed as a plane surface<sup>16</sup>, of each sensitive element of the IRFPA studied. Displacement of the optical center and optical deformation were neglected when mesh was generated.

The second step is the positioning of the road and its equipment in the real world and linking it to the mesh generated in the first step. To simplify this work, the geometry of the road was constrained to linear segments. Three dimensional objects that were eventually introduced on the road scene were reduced to parallelepipeds.

The third (and last) step was the evaluation of the incidence received from the scene, by each sensitive element of the IRFPA in its spectral operating range. Each element of the scene was

modeled as a diffuse-gray plane surfaces in the wavelength band and whole scene was supposed to be at the local thermal equilibrium. The radiosity method<sup>17</sup> was used to compute radiation heat balance at road scene level. As night vision was the topic of interest, Sun incidence was not taken into account in the energy balance. The problem was reduced to heat radiation exchange in a virtual enclosure with or without 3D objects. In the first approach, radiation coming from vertical object was neglected; the sky was also taken into account and assumed to behave as a blackbody.

The local incidence on a sensitive element (cell) of IRFPA was then determined using the following relation between net radiation, configuration factor, transmission coefficient and incidence:

$$E_{ij,\lambda_1 \rightarrow \lambda_2} = \tau J_{ij,\lambda_1 \rightarrow \lambda_2} F_{ij} [W.m^{-2}] \quad (3)$$

with  $[\lambda_1; \lambda_2]$  spectral band,  $\tau$  transmission coefficient,  $F_{ij}$  configuration factor between surface of road viewed and IRFPA cell,  $J_{ij,\lambda_1 \rightarrow \lambda_2}$  net radiation of road surface viewed.

Different approaches were proposed in literature to compute the configuration factor<sup>17</sup> that intervene in Eq. (3) for local incidence estimation. Among them there is the contour integration method<sup>18</sup>, based on the application of the Stoke's theorem. It was chosen for implementation. It reduced the multiple integration over a surface area to a single integration around the boundary of the area. Its expression for the configuration factor of A2 (surface viewed in the road scene) to A1 (IRFPA sensitive element considered) is:

$$F_{21} = \frac{1}{\pi.A_2} \int_{A_1} \int_{A_2} \frac{\cos \theta_1 \cdot \cos \theta_2}{r^2} dA_1 \cdot dA_2 = \frac{1}{2\pi.A_2} \oint_{C_1} \oint_{C_2} \left( \ln \|\vec{S}\| dx_1 dx_2 + \ln \|\vec{S}\| dy_1 dy_2 + \ln \|\vec{S}\| dz_1 dz_2 \right) \quad (4)$$

Where  $\ln \|\vec{S}\| = \ln \left( \sqrt{(x_2 - x_1)^2 + (y_2 - y_1)^2 + (z_2 - z_1)^2} \right)$  is the natural logarithm of distance between locations coming from mathematical solution proposed by E.M. Sparrow<sup>18</sup>. The uses of analytical solutions and of hemicube method were also investigated to reduce the computing time.

Figure C.3.5 shows different steps of the simulation for simplified road scene and LWIR camera.

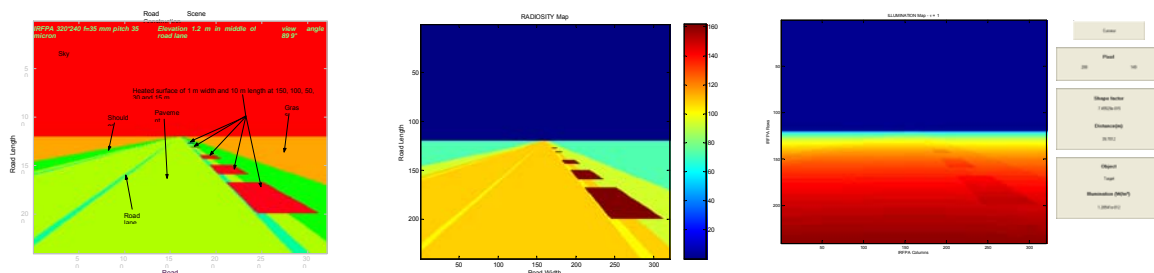

**Figure C.3.5:** Road scene generation (left), net radiation map (middle), Incidence map (right)

Such tool, even though, is not completely achieved (lack of 3D objects insertion in the final radiation heat balance), is enough developed at that stage to evaluate potential solutions by acting on thermo-optical properties at pavement surface level. It allows us to reduce on road trials.

## 12.1.6 TRIALS

### On road trials

The outside test site chosen to make first experimentation is the small regional airport of Autun. It has the advantage of having a large width test track with a straight long part (runaway) and experimentations at night are facilitated by absence of flight. The second interesting aspect is that no vertical vegetation is present on the shoulder of the track which is close to the conditions we have

implemented in the simulation tool developed. Figure C.3.6 show images of this test site in the visible spectrum and in the infrared.



View of the airport test track  
Camera located on the axis

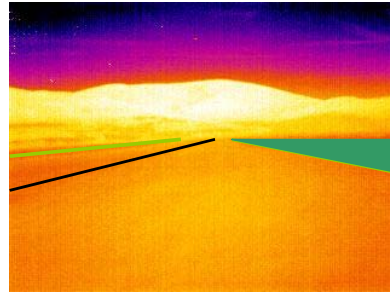

infrared image without object  
Camera located on the slow lane in traffic direction

**Figure C.3.6:** View of the test site in the infrared and the visible spectrum

The infrared images acquired during all these trials were made using an infrared camera in Band III (FLIR S65). Furthermore, pavement surface temperature and atmosphere temperature and relative humidity were also measured. Different infrared and visible images were acquired for different distances between various targets (pedestrian, vehicle, pedestrian + vehicle) and infrared camera, but also for different locations of targets in the width of the pavement and with or without adding vehicle headlights. For instance Figure C.3.7 show images acquired (visible and infrared spectrum) for a distance between camera and pedestrian of 50 m.

Distance 50m – Pedestrian at right		
Infrared – no headlight	Infrared – dipped headlight	Infrared - full headlight
Visible – no headlight	Visible – dipped headlight	Visible - full headlight

**Figure C.3.7:** View of the test site in the infrared and the visible spectrum

Images acquired on this test site were also used to validate part of the infrared vision simulation tool developed. Figure C.3.8 show an infrared image acquired on this test site, its associated road scene construction and the resulting incidence map on the detector (in logarithmic scale) computed using data measured, at local thermal equilibrium, during trials.

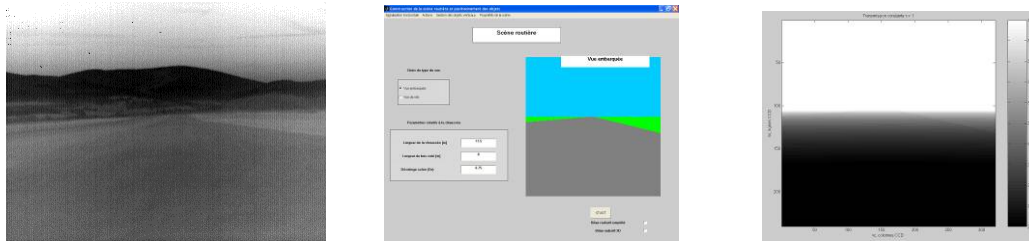

**Figure C.3.8:** View of the test site in the infrared and the visible spectrum

Figure C.3.9 shows for this same road scene incidence map computed in one case by acting on the emissivity of the roadside in orange on left image (set to 0.2) and in the other case by acting on its temperature (set to 10°C over the surface temperature of the carriageway).

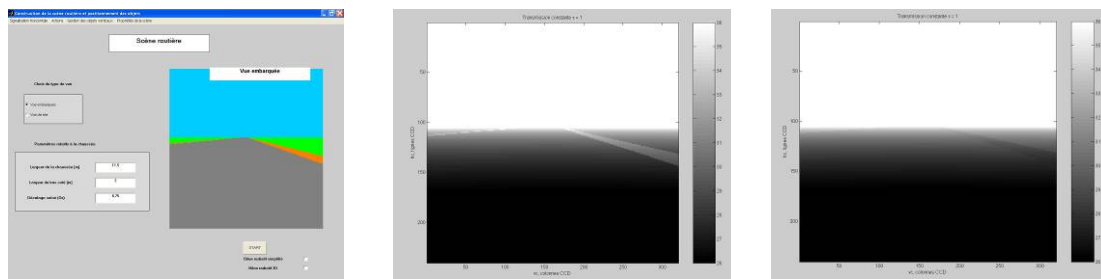

IR scene with roadside Incidence map Roadside with  $\epsilon=0.2$  Incidence map Roadside at  $T=285\text{ K}$   
**Figure C.3.9:** Simulation with Roadside modified properties – IR spectral bandwidth III :  $7.5\text{--}13\ \mu\text{m}$

Except for the sky where, we do not introduce the radiative effect of the surrounding mountains at the horizon, a good agreement in the general distribution of the signal issued from the element of the scene simulated is observed by comparison with the experiment. Simulation tool is then used to evaluate signal that can be available by acting on thermo-optical properties of the pavement surface, for instance by changing its emissivity or its temperature.

### Trials in fog tunnel

The fog tunnel<sup>19</sup> (Figure C.3.10 (left)) consisted of a facility 30 m long, 5.5 m wide, and 2 m high, producing artificial fog in monitored conditions (see Figure C.3.10 (right)). This equipment allowed to study the factors that affect visibility in fog, both during day and night time. An observation station consisting of the front of a car with headlights allows for both photometric measurements and personal observation by individuals seated in the driving position.

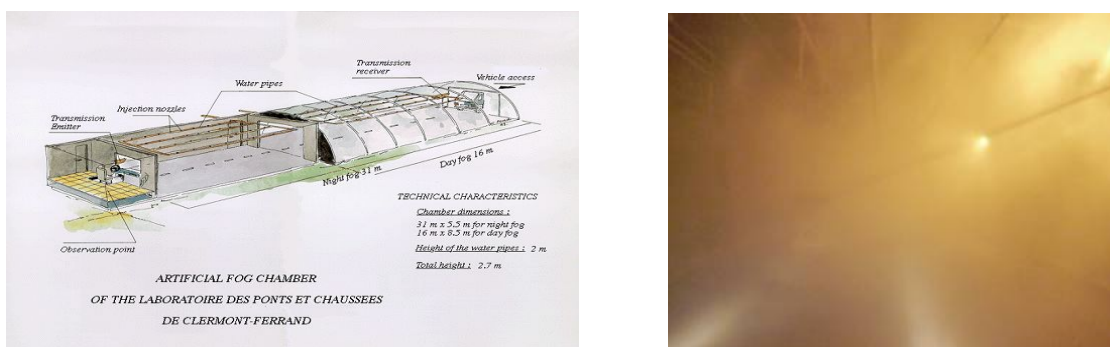
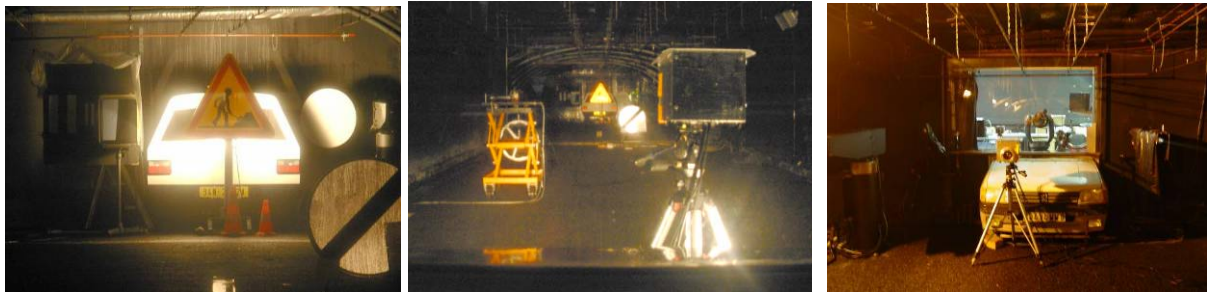

**Figure C.3.10:** Fog tunnel facility scheme (left), Infrared images: MWIR (middle) and LWIR (right)

During experiments water droplet size distribution was measured. Two transmissionmeters, located at 15 and 30 m, were also used to determine the evolution of the meteorological visibility during trials.

Figure C.3.11 present the scene studied in the fog tunnel under night vision conditions. Infrared cameras were placed directly in the fog tunnel which is more closed to road application even though we acquired images in static mode. During trials, the heated panel was located at 27 m for MWIR II, 28 m for LWIR and 29 m for photopic imagery (visible spectrum). The base of the panel was located at

94 cm from the ground level and the upper part of the legs of the little worker drawing at 120 cm. The panel is an equilateral triangle of length 1 m. It is recovered by a 3M reflective wearing material (micro marble type) and the little worker drawing is also compound of a black 3M non reflective material glued on its surface.



**Figure C.3.11:** Road work panel heated by an halogen lamp (left), Road scene viewed from the control room (middle) and Infrared cameras implantation in the fog tunnel (right)

To illustrate image enhancement using infrared vision, some images reported in Figure C.3.12 for different meteorological visibility show what can be seen in the visible spectrum only using car headlight in foggy night conditions. The circular panel located at 15 m is non active and the road works panel is still at 29 m but not visible on the images. Level of illumination measured on the panel are very low, less than 5 cd/m<sup>2</sup>. That's why for low visibility the integration for measurement can reach 10 s due to low signal recorded by the calibrated detector (Photopic camera). For on road application typical integration time required is closed to one millisecond.

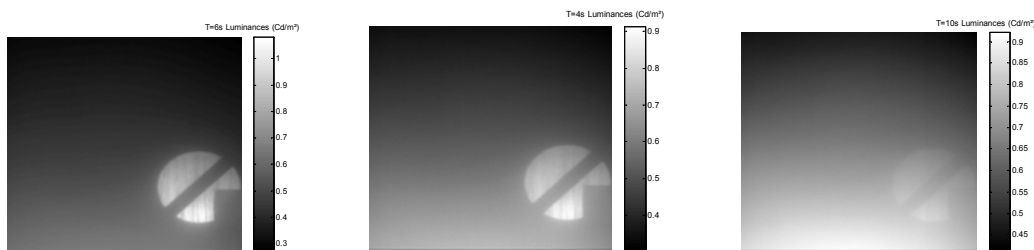
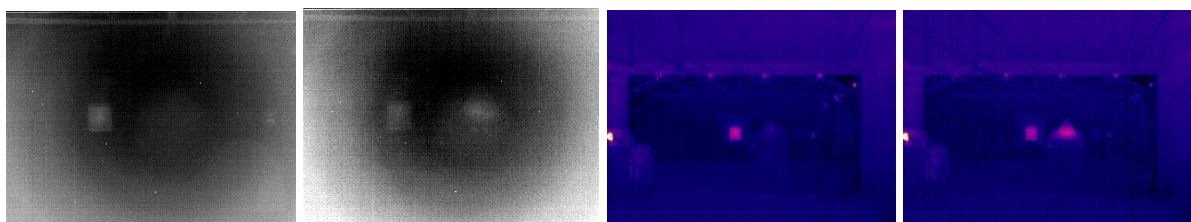

**Figure C.3.12:** Images acquired in the visible spectrum with the Videophotometer with car Headlights and for different meteorological visibilities: left V= 20 m – middle V = 15 m – right V= 12 m

Such images in the visible spectrum have to be compared with infrared ones presented hereafter on Figure C.3.13 to Figure C.3.15 for meteorological visibilities of same range, with and without a thermal excitation on the road works panel.



**Figure C.3.13:** Infrared images: MWIR in grey levels (non active panel on left and active on right) LWIR in pseudo colour levels (non active panel on left and active on right) – V = 22 m



**Figure C.3.14:** Infrared images: MWIR in grey levels (non active panel on left and active on right) LWIR in pseudo colour levels (non active panel on left and active on right) – V = 16 m

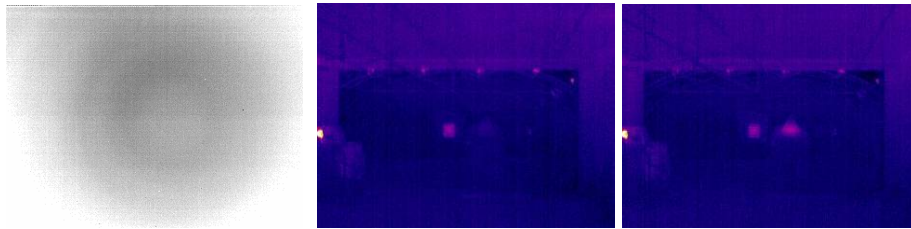

**Figure C.3.15:** Infrared images: MWIR in grey levels (only for active panel) LWIR in pseudo colour levels (non active panel on left and active on right) – V = 12 m

Globally, we observed an enhancement of the visibility from photopic vision by using infrared vision on active thermal panels placed in foggy atmosphere. On the other hand, the panel placed at 13 m and which is not thermally active drive to infrared images where it is less or more included in the background signal. Furthermore, the reflective surface put on this surface (square piece of aluminium) didn't induce a particular contrast in presence of fog. As previously seen for on road trials, no influence of the artificial lighting in fog tunnel or from the car headlights was observed. In infrared bandwidth used, lighting spots of the tunnel and rectangular target, when they are under electrical alimentation, are just particular intensive radiative area in infrared image. The wearing of the road works panel and particularly its information is still readable in infrared bandwidth II, more easily when thermal excitation is applied. For infrared band III information is lost but hot panel remains visible for lower meteorological visibility distance, to preserve information the thermal excitation must be done with appropriated coding distribution. Such trials can also take benefit of using optical configurations adapted to each detector to have a same field of view to facilitate comparison between each spectral bandwidth.

Figure C.3.15 presents the evolution of the active panel or target signal transmission versus the evolution of the meteorological visibility. One will observe that for thin water droplet size 5% of the signal is transmitted for a visibility of 12 m in LWIR spectral band and at 20 m in MWIR. For the other water droplet size such value fall down to 22 m in LWIR spectral band.

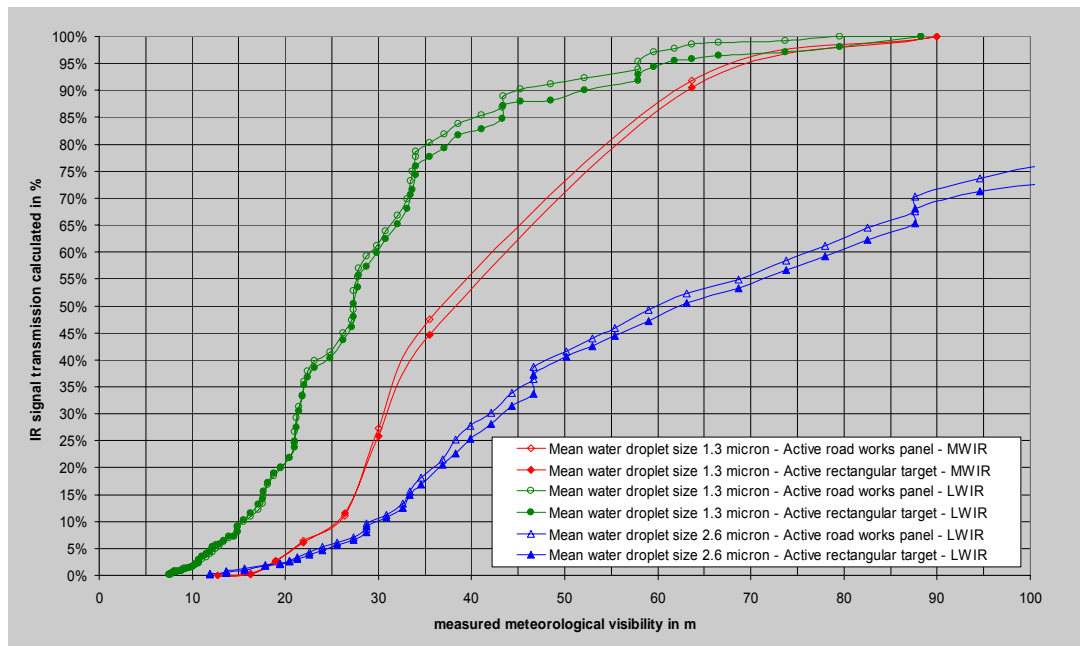

**Figure C.3.15:** Infrared signal transmission evolution versus meteorological visibility measured for different trials (two fogs, targets and infrared bandwidth)

So, efficiency of infrared vision in foggy night conditions also depends on the type of fog, but thermal active panel favour its eye detection on the scene.

### 12.1.7 CONCLUSIONS

Results obtained with the emissivity measurement apparatus has been used to make numerical simulations with the infrared simulation tool developed for simplified road geometries. Nevertheless, the spectral bandwidth used for measurement is still too large with regards to the more restricted spectral bandwidth of infrared vision systems on the market. Some accurate measurements could be undertaken with an experimental setup with a proper sensor in the 7-14  $\mu\text{m}$  spectral bandwidth, and in various directions. Based on the Mie theory, calculations of absorption and scattering coefficients were developed from experimental water droplet size distribution data acquired in a fog tunnel. Monte Carlo simulation, valid when absorption is negligible (i.e., in visible range), allowed to see the influence of each fog type on road sign perception: decrease of the contrast with decrease in meteorological visibility was observed, but also increase of backscattering with decrease of water droplet size in foggy night conditions. The infrared simulation tools developed, even though, it is not completely achieved at that stage (lack of 3D objects insertion in the final radiation heat balance), allows to evaluate potential solutions by acting on thermo-optical properties at pavement surface level and permits to reduce on road trials. For instance, simulations permit to evaluate the size of cooperative elements of infrastructure required to be perceptible on infrared images by taking account the characteristics of on-board infrared vision system used. Experiments on road site and in fog tunnel allowed us to validate numerical simulations. They also have permitted to verify that improving contrast on infrared images by generating a thermal excitation on infrastructure typical elements had to be favour in front of reducing their emissivity in foggy night conditions. Recovering energy from road could be a sustainable solution to generate active thermal elements for on board infrared vision system.

### Acknowledgments

The authors tanks Eric Maguet, Lionel Segaud, Fabrice Delannay and Philippe Morange for their technical contribution to this work.

### REFERENCES

1. JJ. Yon, L. Biancardini, E. Mottin, JL. Tissot and L. Letellier, "Infrared microbolometer sensors and their application in automotive safety", *Advanced Microsystems for Automotive Applications 2003*, Berlin, Germany, 22-23 may 2003.
2. A. Durand, E. de Borniol, R. Vinciguerra, T. Cathala, JJ. Yon, P. Castelein, R. Tronel, G. Destefanis, "IRFPA Modelling : examples and applications in SWIR and LWIR", *Proceedings of SPIE, Electro-Optical and Infrared Systems: Technology and Applications* **5612**, pp 304-314 (2004).
3. P. Marchal, D. Gavrilu, L. Letellier, MM. Meinecke, R. Morris, M. Töns, "SAVE-U : sensor data fusion fot improved Vulnerable Road User detection", *Intelligent Transport Systems and Services*, Budapest, Hungary, 24-26 may 2004.
4. A. Le Goff, J. Latger, P. Kersaudy, "Realistic multispectral simulation including IR simulation", *Proceedings of SPIE, Modeling, Simulation, and Visualization for Real and Virtual Environments* **3694**, pp. 152-163 (1999).
5. T. Poglio, S. Mathieu-Marni, T. Ranchin, E. Savaria, L. Wald, "OSIRIS: a physically bsaed simulation tool to improve training in thermal infred remote sensing over urban areas at high spatial resolution", *J. Remote Sensing of Environment* **104**, pp. 238-246 (2006).
6. L. Poutier, X. Briottet, G. Serrot, C. Miesch, L. Coret, A. Malaplate, F. Lemaître, G. Dedieu, V. Demarez, Y. Kerr, G. Marty, F. Lavenu, JC. Calvet, N. Fritz, MP. Stoll, F. Nerry, "PIRENNE: a multidisciplinary research program about field radiometry", *Proceedings of OPTRO 2002*, Paris, France, January 2002.
7. J.S. Sanders, K.R. Johnson, A.R. Curran, P.L. Rynes, "Ground target infared signature modeling with multiservice electro-optic signature (MuSES) code", *Proceedings of SPIE, Targets and Backgrounds VI: Characterization, Visualization, and the Detection Process* **4029**, pp. 197-204 (2000).
8. L Ibos, M Marchetti, A Boudenne, S Datcu, Y Candau, J Livet, "Infrared Emissivity Measurement Device: Principle and Applications", *Measurement Science and Technology* **17**, pp 2950–2956 (2006).
9. G. Mie, "Optics of turbid media", *Ann. Phys.* **25** (3), pp 377-445 (1908).

10. H.C. Van de Hulst, *Light Scattering by small particles*, ed Dover, 1981.
11. C.F.Bohren, D. R. Huffman, *Absorption and Scattering of Light by Small Particles*, ed.Wiley Interscience, 1983.
12. E. P. SHETTLE et R. W. FENN. « Models for the aerosols of the lower atmosphere and the effects of humidity variations on their optical properties », *Air Force Geophysics Laboratory* **79-0214**, (1979).
13. M. Hess, P. Koepke, I. Schult, "Optical Properties of Aerosols and clouds: The software package OPAC", *Bull. Am. Met. Soc.* **79**, pp 831-844 (1998).
14. J. Dumoulin, F. Delannay et G. Lecamus (2006), "Enhancement of infrared vision for drivers by acting on infrastructure", *TRA 2006*, Göteborg, Sweden.
15. A. Aranda, G. Paez, M. Strojnik-Scholl, "Theoretical comparison of thermal contrast detected with thermal and quantum detector", *Infr. Phys. & Technol.* **46** (6), pp 441-450 (2005).
16. O. Faugeras, *Three-Dimensional Computer Vision : a Geometric Viewpoint*, MIT Press, 1993.
17. R. Siegel and J. Howell, *Thermal radiation heat transfer*, 4<sup>th</sup> edition, ed. Taylor and Francis, 2002.
18. E. M. Sparrow, "A new and simpler formulation for radiative angle factors", *J. Heat Transfer* **85** (2), pp 81-88 (1963).
19. Colomb M., Hirech K., Morange P., Boreux J.J., Lacote P., Dufour J., "Innovative artificial fog production device - A technical facility for research activities", *3<sup>rd</sup> Int. Conf. on Fog*, October 2004.

## **12.2 Road safety through urban design: contribution of “design models”**

David MIET (Laboratoire Régional de l’Ouest Parisien LROP – France)

Dominique TOUJAS (Laboratoire Régional de l’Ouest Parisien LROP – France)

### **Abstract**

When considered in complex urban environments, the improvement of road safety through urban design has to face two kinds of difficulties : (1) First “safety” only constitutes one component of the whole urban design task, implying that by making street designs for safety reasons, one may stimulate some unexpected effects over accessibility, commercial activities, pedestrian practices and other urban uses... effects which may even be contrary to the initial purpose of road safety. (2) Second it is also very difficult to pass, even within the restricted framework of road safety concerns, from the elements of the diagnosis and preliminary studies to some design scenarios. Indeed, a “sum of safety misfits to be avoided” is not sufficient to constitute a street design whereas, in the contrary, a street design necessarily implies more components and decisions than the few parameters taken into account by any diagnosis. The analytical results of a diagnosis (be it a diagnosis of road safety, of commercial welfare, of environmental health ... or even the sum of all of them) clash with the essentially synthetic character of the design activity. This article will show how the "design models" tool may offer some insights and perspectives to remedy this situation.

### **12.2.1 THE DIFFICULT TRANSITION FROM SAFETY DIAGNOSIS TO DESIGN PROPOSALS**

Before the implementation of a design, it is necessary, in order to correctly take safety matters into account, to perform an appropriate diagnosis. In France, a safety diagnosis forms part of a larger general process which unfolds in three stages that are conducted prior to the actual design of the project:

1. Study of safety issues: what types of accidents occur (bodily, material, etc.), who are the victims (pedestrians, cyclists, etc.) and at what location (schools, intersections, etc.)? What are the priority issues for infrastructure administrators?
2. Diagnosis: what factors related to behaviour or to the environment are involved in these accidents? What scenarios emerge from the analysis of accident reports?
3. Design proposals: how should the configuration of the existing project area be modified to reduce accident risks in the future? What are the design principles to be adopted?

Depending on the specific situation, all or part of the stages of this process will be carried out.

In the case of a new project, only the third and last stage applies: there is no existing situation and hence no particular accidents to be analysed. It is thus possible, during all the project phases, to simply evaluate the impact of design decisions and choices on safety so as to avoid the creation of new configurations known to be dangerous. It is this process that is implemented in connection with the Control of Safety relative to Road Projects (CSPR) on French national highways.

In the case of localised operations, after a significant accident for example, stages 2 and 3 will be carried out. The issues (victims, location and type of accident) are in fact already known: what remains to be determined are the circumstances of the accidents before going on to the design proposals. The analysis and understanding of accident circumstances (players, behaviours, interactions with the infrastructure, sociological context, traffic, etc.) enables classification into families (accident scenarios, associated with accidentological and aggravating factors). Project proposals will then consist of disabling the occurrence of situations and behaviours similar to those having led to the studied accidents. It will thus be possible, for example, to prevent a litigious u-turn if such an operation is found to be the cause of recurrent accidents.

In the case of urban design projects for a whole route or an entire district, the three stages of the process must naturally be completed. The first stage devoted to the definition of issues takes on its full significance when the extent and complexity of the study area are such that a certain ordering of purposes is required: which publics have to be protected more particularly? Which places have to be handled with the greatest care?

In the latter case, as in the case of localised operations and new projects, the approach to road safety by urban design comes up against two difficulties, which are moreover encountered to a greater extent in the case of complex urban project (urban areas with multiple users, functions, spaces, traffic control systems, etc.):

(1) Safety constitutes only one component of urban design, so that there is a risk, when providing “safety design” improvements, of causing unexpected consequences on accessibility, commercial activities, conditions for performing certain practices, etc. Some outcomes may not have been expected and could even be counter to the initial aims of safety. Such is the case, for example, when the design reserves part of the space for certain types of users in order to protect them: this protection builds the confidence of such users, which may lead to less attention being paid to others...

(2) It is moreover very difficult, even within the restricted framework of safety studies, to progress from the elements of the diagnosis to the design proposals. An enumeration of problems to be avoided may in fact not be enough to comprise a design project whereas, by contrast, a design inevitably entails more components and decisions than the few parameters allowed for in the diagnosis. Except in very simple cases in which it is decided to physically prevent contact between certain types of users (implementing traffic barriers, for example), a logical link is often difficult to establish between a spatial design and its propensity to provoke or to allow certain types of accidents.

The analytical results of the diagnosis thus come up against the more synthetic nature of design activity.

To solve the first difficulty, the study of safety issues and diagnosis are customarily complemented by other studies and preliminary diagnoses: parking, traffic, lighting, signing, environmental impact, pedestrian ways, commercial activities, etc. However, this overlapping of diagnoses in “layers” independent of each other further compounds the difficulty of progressing from diagnosis to design proposals: it is not, in fact, by extending the already long list of constraints, criteria and objectives to be “taken into account” that the elements of diagnosis will be integrated more reliably in the design. Quite the contrary, the disorganised multiplication of these prior observation elements, and standards of all kinds, rather tends to heighten the conceptual complexities affecting the ability of designers to fully use this knowledge and understanding of the existing situation.

In practice, the second difficulty is thus only partly resolved, and a sort of “conceptual jump” is observed between analysis results and the make-up of design proposals. This passage is nevertheless supported by two types of elements:

-A set of “road safety good practices:” road designs which have proven, empirically, that they were not significantly accident prone.

-A set of “safety design principles:” general rules assumed to have a positive effect on the lowering of accidents, such as “visibility” and “legibility.”

We shall thus see that the “design models” method developed within the framework of NR2C research enables significant advances in the resolution of these two difficulties: the incorporation of safety concerns among all the concerns underlying any transformation of the urban environment, on the one hand, and the solidity of the transition from diagnosis conclusions to design proposals, on the other.

We shall also see that these advances can be achieved by simple extensions of existing tools: by the methodical transformation of “good practices” and “design principles” as they are currently used today.

### **12.2.2 FROM “ROAD SAFETY GOOD PRACTICES” TO “URBANISTIC DESIGN MODELS”: CYCLE PATHS, ROUNDABOUTS, PEDESTRIAN PLATEAUS, ETC.**

Knowledge of the danger level of specific design solutions is mainly empirical: what is known, from observations in a large number of cases, is that some types of design are likely to prevent accidents, whilst other types are, on the contrary, liable to cause some.

The accumulation of observations relative to a large number of accidents has shown the existence of recurrent and general themes which lead to the preparation of special solutions. Such is the case with regard to speed restrictions in town. It can take on the form of general specifications (lowering of speed limit to 50 km/h for example) or special designs which tell the driver what the appropriate speed is (traffic calming devices, narrower lanes). The conversion of a street into a 30-zone (an urban area where circulation speed is limited to 30km/h) combines these two aspects, among others.

The special treatment of intersections is another example of the application of empirical accident knowledge: intersections are crossflow points for traffic of different kinds and speeds (automobiles, motorcycles, cyclists and pedestrians). Conversion into a “roundabout” (to favour vehicle traffic) or a “raised plateau” (to favour soft travel modes) makes it possible to greatly reduce the gravity and occurrence of accidents.

The provision of street configurations specifically dedicated for soft travel modes (cyclists, pedestrians, reduced mobility persons, etc.) enables a reduction in the number of accidents involving them. The same applies to paths or lanes reserved for cyclists: “cycle paths on a widened sidewalk”, for example, protect cyclists from automobiles whilst also keeping pedestrians off the roadway.

Nonetheless, these designs, viewed from the road safety viewpoint (examples of “road safety good practices”) may also be viewed as special occurrences of full-fledged “urbanistic models” whose properties, objectives and intentions can not be summarised by those concerning road safety.

The model of the “cycle path on a widened sidewalk” for example, separates, by its configuration, pedestrians from the edge of the roadway; it thus has a tendency to exclude the use of the sidewalk border for stopping, and steers pedestrian traffic towards the building side. This effect could be desirable in the case of a shop-lined street with attractive surroundings: shopowners will have nothing against the attention of pedestrians being turned towards shop windows. Along unappealing high buildings, by contrast, the application of this cycle path model will ultimately have a tendency to favour local and transit traffic, limiting stopping spaces since sidewalks borders usually constitute a privileged spot for this type of use.

In light of the high complexity of all possible causes and effects of urban phenomena, the contribution of “design models” consists in:

-Deciding to formalise “urbanistic models” in the general sense of the term, which do not favour in principle a given objective, criterion or discipline (safety, traffic, hydrology, lighting...).

-Distributing all these urban considerations “idea by idea:” as it is clearly impossible to group them all under a same general model which would be valid everywhere, the method consists, first, in acknowledging the existence of “design ideas” or “design partis” (such as the cycle path on widened sidewalk) to group and to aggregate, then, all knowledge elements and viewpoints that seem relevant for the understanding of the studied phenomena.

By progressing from the concept of “good practices” to that of “urbanistic models”, we bring in mechanisms and phenomena involved in the explanation of accidents into a more general understanding of the life of studied urban environments: depending on the models considered (cycle paths, bus lanes, sidewalks, arcades, avenues, boulevards, pedestrian ways, alleyways, bus shelters, etc.), safety issues will be mixed with those of aesthetics, water flow, parking, commercial activities, local residences, public transport, city image, etc.

On a first level, this passage from safety good practices to urbanistic design models allows a designer wishing to use a given model for safety purposes to determine its implications from different viewpoints: it enables him to work within a more general understanding of the urban environment while conceiving the place and role of the components he is handling. Doesn't a “line of posts along the edge of a sidewalk” simultaneously represent, depending on the urbanistic model within which it is inserted, a means of preventing litigious parking, a system protecting pedestrians against vehicles, one less circulation lane for pedestrians, a rhythmic composition influencing the aesthetics of the street, a support for persons stopping on the edge of the road before crossing?

On a second level, this passage from safety good practices to urbanistic design models encourages us to consider that, in the final analysis, there is theoretically no design model that is “safer” than another but, rather, that each design model can be conceived of as a special means suited to certain types of situations, making it possible to deal with the issue of safety as an aspect of the general organisation of urban uses. It is not the “roundabout,” the “cycle path on widened sidewalk” or the “levelled street” (a street in which roadway and sidewalks are put at the same level) that are in themselves design solutions safer or less safe than others but, more accurately, it is the use that is made of these urbanistic models in certain contexts.

On a third level, this ongoing from safety good practices to design models considerably facilitates the transition from diagnosis to programmes and then to the definition of design proposals. While the “cycle path on widened sidewalk,” the “roundabout,” the “bus corridor,” etc. taken as safety “good

practices” are rather abstract concepts, taking them not from this special viewpoint but as themselves, as several design ideas, makes them much easier to grasp. The fact that these ideas, once taken from the general viewpoint and not from the special standpoint of safety, offer both the capacity to express needs (draw the attention of passersby to shops and other businesses, provide cyclists with more space, etc.) as well as possibilities of solutions (create a reserved path, setup on sidewalk edge, for example) is a twofold advantage:

-Firstly, for the inhabitants, infrastructure owners and all non-expert persons, who customarily express their desires and objectives by means of terms referring to solutions (need for a roundabout rather than the slowing of vehicles, for a cycle path rather than good conditions of circulation for cyclists, etc.).

-Secondly, for the designers themselves, who handle, combine and deform naturally urbanistic ideas of this kind when imagining different ways of transforming an existing site and current functioning patterns.

Briefly stated, going from “good practices” relative to safety (or lighting, traffic, parking, etc.) to the study and definition of real “urbanistic models” means opting for the organisation of all available urban knowledges (including that related to safety) around ideas which can be worked during the definition of design programmes and projects.

In this respect, the method of design models (1) makes it possible for all these elements of know-how to be effectively incorporated in the urban design processes and (2) constitutes a solid support for the improvement of the organisation, distribution and consolidation of the urban design process itself, thus considered as an iterative expressing of needs and design solutions.

### **12.2.3 FROM “ROAD SAFETY DESIGN PRINCIPLES” TO “URBANISTIC DESIGN OPERATORS”: VISIBILITY, LEGIBILITY, COHERENCE, ETC.**

The tools available for the improvement of road safety by design are not limited to good practices. A certain number of more fundamental studies on the question of safety have in fact made it possible to support certain principles or certain general rules to guide designers in the definition of projects.

These studies are based on a systemic approach to safety matters. They consider that the occurrence of accidents can not be summarised as the responsibility of one or more players. Accidents are regarded as complex phenomena involving interactions between various users and their environments at different scales.

On the local scale, it is the man-vehicle-environment interaction which is considered. An accident is the malfunctioning of this man-vehicle-environment system or of the pedestrian-environment system. In this context, three major concepts take part, among other things, in the functioning of the system:

-“Visibility:” which is obtained when a design enables users to gain access sufficiently early and accurately to those part of the visual information of their environment that may allow them to adapt their behaviour in order to avoid causing an accident: pedestrians, in the proximity of a protected passage, must be afforded a sufficiently distant visibility to avoid vehicles as they cross the roadway.

-“Legibility:” which is obtained when a design enables users to understand those aspects of the functioning of their environment that may allow them to adapt their behaviour in order to avoid causing an accident: types of permissible use, speed to be adopted, etc.

-“Coherence:” which is obtained when the elements of a design do not produce any contradiction in the reading of the information being conveyed that would be capable of causing accidents: a very wide roadway with multiple lanes in an unbuilt environment might appear contradictory, in the information it transmits to drivers, with signs indicating a speed limit of 50 km/h for example.

Nevertheless, while these concepts are meaningful from the viewpoint of the safety diagnosis, they have only a rather limited impact when used in the design process for a relatively complex urban project. When accidents are diagnosed, “visibility” and “legibility” will always be relevant explanatory factors, for as they were defined in this context, they will cover every possibility of the safety system malfunctioning:

-“Visibility for safety” consists in providing access to information which, if not transmitted, could lead to accidents.

-“Legibility for safety” consists in making comprehensible certain functioning aspects which, if not understood, could lead to accidents.

However, it would be possible to define other concepts of visibility and legibility of equal legitimacy from the viewpoint of urban design:

-“Visibility for commercial activity” could consist in giving access to information which, if it were not transmitted, could cause a drop in the sales of local businesses, for example: shops obviously want to make their display windows and signs visible.

-“Legibility for commercial activity” could consist in making understandable certain functioning aspects of locations which, if not understood, could cause a decline in the number of people who patronise local businesses: proper understanding of access and parking availability, for example, are not negligible in this regard.

The same would be true of “visibility/legibility for aesthetic pleasure” or “visibility/legibility for waste treatment,” etc..

When an urban project is being designed, the concepts of legibility and visibility can no longer be used in a sectoral manner, because new forms are not imagined and conceived by simply verifying whether they are conform or not from the safety viewpoint (visible, legible, etc.), from the aesthetic viewpoint (visible, legible, etc.), or from viewpoint of shops, businesses, etc.. To perform these verifications, and the adjustments they imply, it is in fact necessary to have already conceived these forms, by means of concepts which are not of the same nature than those used to verify their post-conformity.

In practice, designers also use these “visibility” and “legibility” concepts. However, these terms no longer have the same meaning: “visibility” and “legibility” are taken as “design operators” which may be specified, depending on circumstances, into different modes of interaction between the urban spatial arrangements on one hand and the uses they support on the other: any message may be communicated, for example, on the mode of visibility (size, recurrence, contrast, etc.) or on the mode of reliability, (honesty, uniformity, certainty, etc.).

A good part of the design work precisely consists in forming certain modes of interaction between the spatial arrangements of a city and its uses: in determining the ways these arrangements could support certain social organisations. It has been seen, for example, that the “mode of visibility” could relate to both road safety and health of commercial activities along a street. It is in fact possible for the visibility of shops to be contrary to road safety and, conversely, for visibility oriented to road safety to be detrimental to the visibility of shops and businesses. Many of our cities entrances experience, for example, over-visibility due to signs dealing alternately with commercial activities and traffic regulation.

This mode of “visibility” is however not the only way to ensure road safety or to enhance the appeal of shops and businesses. It would be possible to dedicate visibility to shops and businesses, for example, and ensure road safety through “reliability”: simplicity, regularity, predictability. Or, on the contrary, to confine visibility to road safety and ensure the health of shops and businesses through reliability: parking places always available, extended opening hours, easy and regular access, etc.

While in the narrow system of road safety studies, visibility and legibility are always to be increased (they always tend towards improved accident prevention), this is absolutely not the case from the viewpoint of the urban design process which consists, on the contrary, in choosing (depending on the circumstances and on the prioritised purposes of people) certain modes, rather than others, of interaction between the urban spatial arrangements and their uses. Yet, visibility and accessibility are only some among other possible modes of organisation that make it possible to ensure road safety but also, as we have seen it, the health of businesses, traffic fluidity, aesthetic appeal, etc.

This is what differentiates, to our eyes, the road safety “principles” or “rules” from the “urbanistic design operators”. Just as we went from safety “good practices” to “urbanistic models,” by defining design models which can be used to pass from diagnosis to design proposals, our approach has consisted here, with regard to general concepts, in going from this notion of “sectoral design principle” (useful for verifying the conformity of a project or for adjusting certain project configurations) to that of “urbanistic design operator”, useful for implementing and ensuring progress in the design process.

#### **12.2.4 “ROAD SAFETY” AND THE “FIVE ELEMENTARY QUALITIES OF A STREET”**

We shall now provide, in concluding this article, an example of an urbanistic design operator that we have developed in connection with NR2C research. Of course, what is involved here is just one among many other possible operators for dealing with safety questions, also making it possible to approach questions of ambience, image, commercial activity, etc. These operators are thus more general than urbanistic design models, which focus for their part on specific urban forms or design ideas of a specific nature (cycle paths, bus corridors, avenues, arcades, etc.). But they still make it possible to consider the articulation between different viewpoints, trades, intentions and purposes which are led to cohabit during the project design process.

We thus propose the operator of the “5 elementary qualities” which comprise a way to describe and to consider in a systemic manner the qualities and performances that society expects from streets and public spaces. This design operator seeks to ensure the grasping of not only the most important dimensions of the human experience of the urban environment, but also the relations which intrinsically link these dimensions to each other.

We base ourselves, unlike the analytical approaches, on the postulate that all the qualities of concern to us are, in urban areas at least, basically dependent on each other: our premise is that the “safety” and “reliability” of a street are not independent of its “animation” and of its “convivial” character, and

that the “adaptable” or “embraceable” characteristics of a street are not independent of its “practical” and “legible” aspects.

We thus postulate that all the qualities that may be expected from a street or a public space, which are also different ways of using any spatial arrangement, can be formulated in the terms of 5 elementary qualities which are “vitality”, “reliability”, “firmness”, “accessibility” and “sympathy.”

### The 5 elementary qualities of the use of a street or a public space

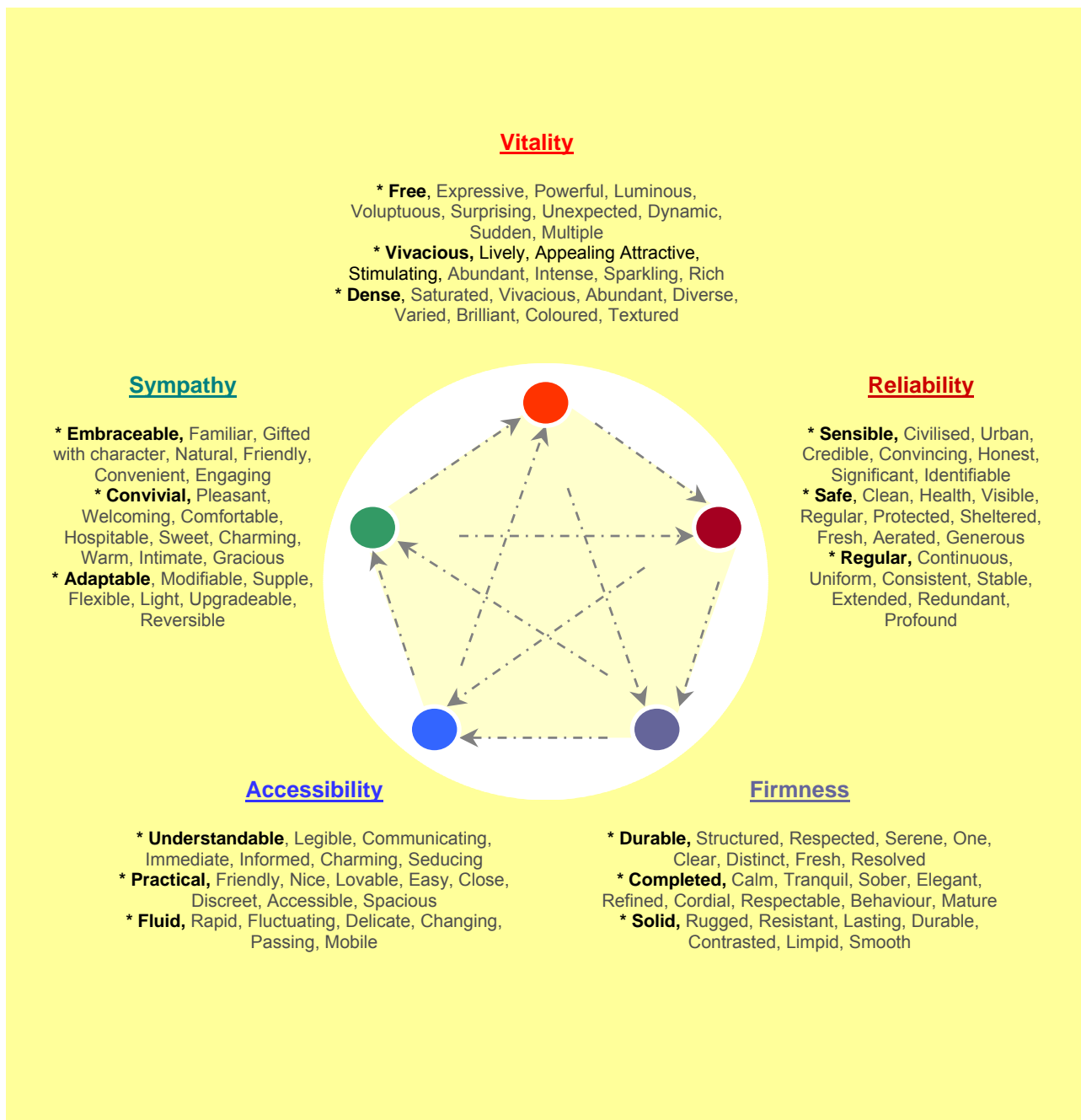

These 5 elementary qualities are moreover organised so that there are two types of processes which explain their production:

1.A relation of generation (in a circle and clockwise): vitality generates reliability which generates firmness which generates accessibility which generates sympathy which generates vitality, and so on.

2.A relation of mastering (star fashion and clockwise): vitality masters firmness which masters sympathy which masters reliability which masters accessibility which masters vitality, and so on.

It is important to understand that according to this systemic and qualitative mode of thinking, what is involved for each project or for each model is not the choice between “reliability”, “vitality”, “accessibility”, etc.. What is involved, quite the contrary, is the understanding that if “vitality” is wished, then at least some “sympathy” is necessary while care must be taken to temper excessive “accessibility.” It must be understood again that if it is “accessibility” which is of interest to the infrastructure owner, some “firmness” is at least necessary and care must be taken to avoid excessive “reliability,” etc.

This design operator makes it possible to consider safety or security, for example, not as phenomena that may be measured in themselves but rather as properties of certain modes of organisation of streets uses: the vitality of the “levelled street” model (complexity, density) is not the vitality of the “multi-functional street” model (rapidity, simplicity); the reliability of an avenue is not the reliability of a boulevard; the sympathy of an arcade is not the sympathy of a fountain; and the safety of a buslane corridor is not the safety of a roadway open to all circulations.

Thus, no design model of a street or a public space is more “reliable” or more “sympathetic” than any another. Rather, the operator of the 5 elementary qualities makes it possible to imagine the different ways by which each of these design models can achieve “sympathy”, “reliability”, “accessibility,” etc.

According to the diagram of the 5 elementary qualities, we find the hypothesis according to which safety and security are elements of “reliability,” something everybody already knew. What then is the contribution of this kind of diagram for the analysis of these questions? The diagram of the 5 qualities in fact proposes 4 hypotheses on safety and security:

1.That safety and security are produced by vitality, i.e. that without vitality, safety and security are impossible to achieve. This is easily verified with some examples. It is known that pedestrian streets are perceived at night as less safe than streets handling automobile traffic. At least some animation, agitation and people (i.e. according to the diagram, at least some level of vitality) appear necessary so that the feeling of safety or security emerges from a situation. It is moreover well known that the presence of a crowd can offer more safety, to the extent for example that the crowd constitutes a sort of continuous mutual watch.

2.That safety and security produce firmness, that without safety or security, firmness and its related qualities (respect, serenity, calm, tranquillity, etc.) can not arise. These are things that appear verifiable, once again: the feeling of safety has a tendency to provoke, in people experiencing it, a certain serenity and a certain tranquillity.

3.That sympathy masters safety and security, that too much sympathy (familiarity, comfort, sweetness, softness) annihilates both safety and security. Once again, the reasoning appears correct: it is in the

daily and familiar routes that most highway accidents occur, doubtless owing to a certain relaxing of attention of drivers who find themselves in a known area, in a situation which can become so comfortable that it will become dangerous.

4. That safety and security master accessibility, that too much safety and security annihilate any possibility of accessibility (rapidity, fluidity, ease, discretion, etc.). It is also possible to cite some examples which confirm this situation: the safest places are obviously not those which are the easiest to access, and it is evident that certain locations become inaccessible when a certain safety or security threshold is exceeded; it is also remarkable that safety devices slow the movements, and that they introduce checks which do not facilitate mobility, discretion or ease, which are all qualities related to accessibility.

What is important to consider, in the verification of these few hypotheses, is, on the one hand, each of these hypotheses in themselves, despite the fact that they appear verifiable most of the time in an intuitive manner by simple reasoning and, on the other hand, the articulation of these hypotheses with each other.

However, what must be especially kept in mind, from the design process viewpoint, is how the questions of urban safety and security are linked to other phenomena which are apparently distant but which are in fact directly related as factors or as products of these questions: that safety and security are produced by a certain vitality of the situation, and that they can suffer by excess sympathy, for example...

Let us take another one: what are the main components of the question of a buslane safety?

1. Firstly, a certain vitality, i.e. a certain minimum traffic on the buslane so that it does not appear deserted; it is in fact for such reasons that buslanes can be violated by automobiles or motorcycles when they can not resist the temptation to use this free space which is empty most of the time. A sufficiently increased use of the buslane will thus be a safety factor.

2. Secondly, care must be taken to avoid causing excessive sympathy, in particular in bus drivers who drive in a space which is dedicated entirely to them and which thus becomes relatively comfortable. As the space is reserved and configured for the buses, they can drive in full tranquillity and at a good speed which could, in certain cases, give rise to dangerous situations. What is important is not to give the bus driver the idea that the situation is very easy, likeable and comfortable, which is indeed the potential danger of any buslane.

Finally, a last example: what are the important components of the question of safety of a "levelled street", i.e. a street designed with sidewalks lowered to the level of the roadway and on which pedestrians are induced to take over a large part of the roadway when circumstances allow?

1. Firstly, a certain vitality, i.e. in the case of a levelled street, a certain diversity of uses and of travel modes as well as sufficient density of use so that the situation appears to be vivacious and animated, and so that the different users pay attention to each other. What produces the safety of a level street is this necessary liveliness which keeps all the users on the alert and without which the levelled street, despite its lines of bollards, is rather less safe than an ordinary street with sidewalks.

2. Secondly, care must be taken to avoid excessive sympathy, in particular for pedestrians who are to be able to walk easily over the entire width of the street, while they are not allowed to stay anywhere along the street: the level street is designed to facilitate movements; it maintains a sufficiently low level of comfort to dissuade stopping or grouping.

Hence, that is how this operator of the “5 elementary qualities” makes it possible to formulate some solid hypotheses regarding phenomena which keep together the different qualities of a street.

We see clearly that this sort of tool is not usable to check whether a given design complies with safety standards, but rather to direct thinking along the lines of a logic of design, for the progressive definition of urban forms and uses modes of organisation which are to structure the transformation of one specific site.

Regarded both as bases and as complements to urbanistic “design models”, these “design operators” could contribute to the integration of knowledge, studies, diagnoses and issues of road safety into global urban design projects. The designs resulting from this kind of process may not involve improvements simply complying with safety rules, but configurations based, in part only, on the spatial and social organisation of road safety.

## REFERENCES

NR2C – Deliv. 1.2: Specifications and preliminary concepts for the design of multimodal streets.

NR2C – Deliv. 1.3: Design models for the design of multimodal streets.

BRENAC Th. et al., Scénarios types d’accidents impliquant des piétons, Lavoisier Editions, 2003.

CERTU, Etudes de sécurité des déplacements en agglomération, 2006.

CERTU, Villes plus sûres, quartiers sans accidents, 1990.

CETUR, Sécurité des routes et des rues, 1992.

## Appendices to Part A

### Developments required

- I. New age binder design technologies.
- II. Lifetime engineering for roads.
- III. Asset management tools.
- IV. Modular prefabricated pavements.
- V. Low temperature asphalt with reclaimed asphalt.
- VI. Bridge eco-assessment.
- VII. TYROSAFE: optimizing tyre-road interaction.
- VIII. Energy controlled pavements.
- IX. Integrated models of urban (human) design.



## ANNEX I: NEW AGE BINDER DESIGN

1.	<b>Project name</b>
	<b>NEW AGE BINDER DESIGN (NANO) TECHNOLOGIES</b>
2.	<b>Contribution to NR2C concept</b>
	Reliable and Green Infrastructure
3.	<b>What's the problem?</b>
	<p>By means of incremental upgrades, the road-engineering sector has been able to meet the growing road transport demands over the last decades. Without drastically changing the concepts of design or the way of physical/mechanical material testing, the sector has managed to improve the performance of road constructions and asphalt mixes. Learning on the job, long-term performance tests in practice and many other forms of comparative empirical research in this period have provided a great deal of knowledge and expertise about behaviour and performance of structures and materials. But nobody can explain which physical and chemical processes are exactly the driving forces of phenomena like ageing and healing which affect the long-term performance. The currently used mechanical and physical test equipment based on beating, pulling, pushing and bending specimens cannot detect these phenomena. These tests have been designed for comparative research to separate the chaff from the wheat and are not capable of predicting the long-term behaviour and performance of pavement materials and mixes.</p> <p>Better understanding of the behaviour and performance of asphalt layers requires knowledge about the intrinsic properties of the asphalt components. Knowledge about the changes of the intrinsic properties of binders during the entire life cycle of asphalt is essential for managing and controlling the above-mentioned phenomena from the start. The physical and chemical processes during production, processing and use of the asphalt mixtures undoubtedly lead to mutations of the molecules inside the bitumen. How and to what extent? Answering these questions will make it possible to create tailor-made bitumen (including bio or agro binders and other substitutes) and asphalt mixtures of higher qualities. To develop this knowledge the road-engineering sector must cooperate with other disciplines like physics, chemistry and biology and apply their micron and nano research technologies. The potency of these new technologies has been demonstrated in many other sectors. For example, with respect to the building sector these technologies have contributed to the development of self-healing concrete and coatings. The introduction of these technologies in the road-engineering sector is also strongly recommended by ERTRAC in the Strategic Research Agenda.</p>
4.	<b>How bad/urgent is the problem?</b>
	<p>Society's quality standards and expectations for the future with respect to infrastructure networks will vary little worldwide: reliable and available around the clock at socially acceptable costs. Durable, long-life infrastructure with low maintenance and smart, quick maintenance techniques are the solutions for meeting these requirements. To bear the increasing traffic loads, new materials and products will have to be developed. A better understanding of the failure mechanisms of materials is an essential stepping-stone for that purpose. Today's research toolbox lacks tests to look inside materials and to determine their intrinsic properties. Furthermore, the common empirical research approach is too time-consuming to respond to the intensity of new social demands. Increasingly, road engineering research has to cross the boundaries into the world of physics, chemistry and biology and apply their technologies to discover the phenomena forcing the degradation of construction components and materials. Knowledge and experience with matter at nano-level are necessary to support the objective-driven creation of new materials and systems with pre-defined properties and behaviour.</p> <p>Managing the behaviour and performance of asphalt mixtures will be the greatest challenge for the coming decades.</p>

<b>5.</b>	<b>Who's the owner of the problem and why?</b>
	<p>Generally speaking, the realisation of innovations is primarily the task of trade and industry. If interested, neither can permit high investment costs for developing and implementing new research technologies in the road building sector. As long as new expensive test facilities are required and the results of the search for a new approach are uncertain and unknown, a "wait and see" attitude prevails which frustrates the introduction of new technologies. European-wide cooperation between public partners, private partners and scientific institutes and governmental support and funding are the key factors to success.</p> <p>The application of micron and nano technologies for researching road building materials can be characterised as totally new. On a very modest scale, several European universities are experimenting with these types of research for road engineering purposes. Only the availability of funds can boost this research to deliver the first results within a few years.</p>
<b>6.</b>	<b>Expected results of the research?</b>
	<p>The objective of the proposed project is to stimulate and promote the application of micron and nano technologies for research purposes in the road building sector. Experiments must show that these technologies will generate the essential breakthrough knowledge needed to solve today's major problems with respect to behaviour and performance of road and materials. Only by understanding what are the driving forces of failure mechanisms and knowing which intrinsic parts of the mixing components are responsible for the behaviour of a material or product can the right measurements be taken to reduce or prevent failure.</p> <p>The results of the project offer the industry new challenges to develop high quality materials and proper products. The project will lead to a new generation of high added-value competitive products and services with superior performance across a range of applications in the road building sector.</p> <p>Moreover, the basic quick win of the project will be the cooperation between various disciplines.</p>
<b>7.</b>	<b>Main users of the results and why?</b>
	<p>Finally the industry (manufacturers, suppliers and contractors) operating within the road building sector will be the main user of the results of this project. This project will stimulate innovation in the road-engineering sector.</p> <p>Understanding what is really happening in practice supports the proper design of new products and leads to performance-based testing. On this basis, road authorities can confidently tender requirements in contracts that are fully performance-based.</p> <p>The use of micron and nano technologies will reduce the characteristic 'engineering judgement' level of the branch in favour of a more scientific level. This will stimulate scientific institutes and universities to focus more on developments and innovations on behalf of the road building industry.</p>
<b>8.</b>	<b>Costs/benefits</b>
	<p>The knowledge generated by means of these new technologies will affect the development of road building materials and products of high quality and focus on their specific functions in the construction. Lifetime extensions of at least 20% are possible. Although these high quality materials and products will be more expensive than the current ones, savings in the costs of maintenance of 10 à 15% a year become realistic in the mid term. European-wide these benefits can run to hundreds of millions of Euros every year. Besides the initial maintenance costs, the economic loss from traffic congestion caused by maintenance work will decrease, thus boosting total benefits. Lifetime extensions of materials and products will also result in the saving of natural resources.</p> <p>To achieve this in the short term, this type of research needs a financial impulse of 1.5 to 2 million Euros a year over a four to five year period.</p>

## ANNEX II: LIFETIME ENGINEERING

<b>1.</b>	<b>Project name</b>
	<b>LIFETIME ENGINEERING FOR ROADS</b>
<b>2.</b>	<b>Contribution to NR2C concept</b>
	Reliable Infrastructure, Safe & Smart/Green and Human Infrastructure
<b>3.</b>	<b>What's the problem?</b>
	<p>A typical problem of high value infrastructure assets is that their relatively long life and the decisions on short-term repairs and maintenance can be rather contradictory. This also applies to “traditionally” designed highways which can be characterised by the following main features:</p> <ul style="list-style-type: none"> <li>• the design concentrates on the reaction-resistance (and not the durability) of the structure to the anticipated loads mainly just after the completion of the facility,</li> <li>• it primarily considers the construction (initial) costs minus the later maintenance and rehabilitation expenditure and very rarely the future environmental and human aspects throughout the lifetime,</li> <li>• the design activities deal with the whole structure as an entity, do not consider its “modules” separately although the loads, lifetime expectancies and eventual recycling techniques may be basically different (i.e. no “modular” design is applied),</li> <li>• the designers do not generally cooperate with the experts of other sciences (e.g. physicists, chemists, mathematicians, system engineers, etc.) who could make a significant contribution to the complexity and depth of the road design.</li> </ul> <p>Lifetime engineering, a new science developed during the mid 1990s (Asko Sarja, Finland) could solve the above problems. Although the main principles of lifetime engineering were initially applied to buildings, industrial facilities and bridges, they can and should also be used for highways.</p>
<b>4.</b>	<b>How bad/urgent is the problem?</b>
	The obvious and globally accepted need for sustainable development including sustainable transport underlines the urgency of the problem outlined under 3. The short-term and too confined (not complex) design activities do not take into account the future consequences, which can be of economic, environmental and/or human nature. This attitude must change as soon as possible to a design methodology which is much more responsible for the next generation. Lifetime engineering offers this possibility although comprehensive research activities and training of the parties interested is still required.
<b>5.</b>	<b>Who's the owner of the problem and why?</b>
	<p>The obvious main interested party is the road designer, whose traditional activity must be widened and deepened by taking into account more aspects and much longer time ranges than before, as well as requiring more cooperation with the experts of other related sciences. Of course, these latter experts are also among the “owners” of the problem as they would be involved in road designs, a new task for them.</p> <p>The road authorities (as owners or managers) are also very interested in this new type of design since their road assets could be preserved more efficiently which is one of the main goals of their asset management.</p> <p>The whole population including the travelling public would also benefit from the use of the principles of lifetime engineering for roads since this type of design is highly sensitive to environmental issues and, more importantly, human aspects like toxic ingredients, safety, comfort, etc.</p>

<b>6.</b>	<b>Expected results of the research?</b>
	<p>The most important result of the research activities could be a significant contribution to the “sustainable development” in each country considered. This is obvious from the very fact that the lifetime engineering forecasts and takes into account, among others, the environmental and human aspects throughout the whole life of the road infrastructure. It thus relieves any negative (adverse) conditions facing the next generation(s) when trying to solve their problems.</p> <p>Significant economic results can be expected if – following the basic principles of lifetime engineering – the traditional “reaction (resistance) type” pavement design is transformed into “durability type” meaning that the predicted changing of loads and reactions (strength) of the pavement structure during the entire life is considered, thus minimising life cycle costs.</p> <p>It can be seen that this complex pavement design methodology can be directly or indirectly applied in various branches of the national economy.</p>
<b>7.</b>	<b>Main users of the results and why?</b>
	<p>The successful implementation of the lifetime engineering principles in road pavement design could be used by the whole community for the following reasons:</p> <ul style="list-style-type: none"> <li>• the realistic anticipation of future (traffic and environmental) loads facilitates the prediction of pavement deterioration already during the pavement design phase. This enables optimum improving interventions to be implemented, thus raising the satisfaction level of road users with regard to safety, comfort and economy;</li> <li>• the whole life costs of the road infrastructure can be reduced by minimising road user costs since the time delay costs, extra vehicle operation costs and additional accident costs during road works are much lower than before;</li> <li>• the new principles also concentrate on minimising the environmental impact (use of toxic materials, air pollution, water pollution, soil pollution, traffic rolling noise, etc.) which can benefit the whole population;</li> <li>• the recycling (or possible reuse) of road materials is also predicted and planned in the early design phase producing environmental benefits and financial savings for the whole community (everybody has an interest in this because taxpayers’ money is involved in the development and the management of public highway networks);</li> <li>• human factors such as safety, comfort and health risks are among the aspects considered in lifetime engineering related to the whole pavement duration.</li> </ul>
<b>8.</b>	<b>Costs/benefits</b>
	<p>The preparation of the implementation of lifetime engineering principles for roads requires various several interrelated research projects involving 5-10 million Euros. Since the road designers and experts would cooperate to achieve higher level road projects, they would need additional, specialised expertise. Teaching and training for some 1-2 million Euros in an average-sized European Union country would be an additional cost.</p> <p>However, the benefits resulting from the successful application of the principles of lifetime engineering for road pavements are much higher than the implementation costs. The yearly public road management costs in a EU country amounts to 100-2000 million Euros. If – conservatively – just 5% cost saving in the road management is predicted as a result of the much more complex pavement design based on lifetime engineering principles, the benefits would compensate the whole costs in some months, maximum 1 year, depending on the size of the country.</p>

## ANNEX III: ASSET MANAGEMENT TOOLS

1.	<b>Project name</b>
	<b>ASSET MANAGEMENT TOOLS</b>
2.	<b>Contribution to NR2C concept</b>
	Reliable Infrastructure and Safe & Smart Infrastructure
3.	<b>What's the problem?</b>
	<p>Road infrastructure is built to satisfy the need for safe, economic and comfortable transport of goods and people. To fulfil these requirements and services to the users, this infrastructure must meet certain quality standards on many aspects, like skid resistance, evenness and noise emission. These properties must be created and maintained throughout the whole lifetime of the road. The proprietors of the public infrastructure, represented in most countries by governmental, provincial and municipal road authorities, are responsible for ensuring the conditions of the road networks. Preservation of the assets value is one of the main tasks of these central, regional and municipal institutions.</p> <p>Besides the preservation of the existing networks, these institutions have to deal with growing demands from society concerning the service level of the networks: undisturbed traffic flows with a minimum impact on the environment. However, as the result of increasingly high living standards, the number of road vehicles and subsequently the traffic volume and axle loads are constantly growing. The more traffic on the roads, the more deterioration of the infrastructure components, but also the higher the sensitivity of the road systems to disruption in the traffic flows resulting from maintenance work and accidents. Furthermore, this rise in the amount of traffic produces a correspondingly negative impact on the environment, resulting in air pollution and noise emission affecting the health and quality of life of substantial numbers of people living alongside the road networks.</p> <p>In general, the available financial resources are far from the justified needs, which are also partly contradictory. The task of the road authorities is to find the right balance between preserving or rehabilitating the existing networks and implementing new demands or requirements. A coordinated asset management system could make a significant contribution in this. Management tools must be developed to support decision-making by road authorities with respect to maintenance strategies and reserving funds for preserving and rehabilitating the road networks</p>
4.	<b>How bad/urgent is the problem?</b>
	<p>The number of road vehicles, and consequently the road traffic volumes and axle loads are constantly growing in every country. Higher living standards increase people's expectations with regard to quality highway service. They need more roads, preferably expressways with higher comfort and safety standards. If they are not satisfied with the available highway infrastructure, they increasingly turn to civil bodies (associations) to express their lack of satisfaction or even protest against the present situation with certain political consequences. Organised coordination of activities, i.e. asset management, is therefore very important for the road authorities if they are to relieve this tension.</p>
5.	<b>Who's the owner of the problem and why?</b>
	<p>The owners of the problem (i.e. preparing optimal road asset management) are obviously the road authorities in their proprietary and/or managerial roles. Successful completion of research in the field would enable the road authorities to use its results by creating efficient asset management for their highway networks.</p>

<b>6.</b>	<b>Expected results of the research?</b>
	<p>In many European countries the expansion of the existing infrastructure dates from the 1970s and 1980s and are therefore reaching the end of their serviceability. In this context several countries on the five continents have already been developing a kind of asset management for their respective highway networks. But – as the recent worldwide questionnaire survey of a PIARC Technical Committee has proved – fully operational and really successful road asset management is nowhere near completion.</p> <p>Knowledge about the condition of the road networks is essential for planning the cost of maintenance and rehabilitation over a period of at least ten years. The realisation of such a planning requires the development of monitoring systems to quickly establish the condition of the infrastructure, performance models for structures, materials and maintenance techniques to forecast maintenance necessary year by year. These developments have to be accompanied by research to fund and qualify the various service levels operational today: which intervention levels for maintenance work must be qualified as ‘hard’ (essential) and ‘smart’ (less important) in terms of safety and the environment, for example. These proposed tools form the basic stepping-stones of modern network management.</p>
<b>7.</b>	<b>Main users of the results and why?</b>
	<p>The results of the proposed research activities would be directly used by the road owners and road managers, i.e. state or municipality road authorities. Their managing activities could be significantly improved by the more efficient preservation of their highway assets, for example.</p> <p>Perhaps more importantly, the whole travelling public can be mentioned as the user of the expected research results since the higher level management of the highway assets clearly affect its serviceability level in positive terms and hence the satisfaction of road users.</p> <p>As an additional user of the research results, the population (dwellers) along the roads can be mentioned since the high quality management of highways reduces the environmental impact on them.</p>
<b>8.</b>	<b>Costs/benefits</b>
	<p>The estimated expenditure of these extensive research activities could be around 10 million Euros. However, the expected much higher benefits can come from the following main sources:</p> <ul style="list-style-type: none"> <li>• the whole management system is better organised resulting in significant cost savings,</li> <li>• the most reliable knowledge about the technical and condition data of the highway network concerned as well as the availability of sophisticated management systems as useful technical tools can significantly contribute to “nearly optimum” decisions with long-term benefits as lower life-cycle costs,</li> <li>• the resulting high quality highway asset management reduces the costs of road users in terms of lower vehicle operating costs, accident costs and time (delay) costs (less traffic disruption as a result of the higher life cycles of more efficient pavement condition improving interventions).</li> </ul> <p>The assets value of the national highways system in the countries of the European Union usually amounts to 10-100 billion Euros, while 1.0-2.0% of the gross value (some 100-2000 million Euro) is spent yearly on maintenance and rehabilitation. If just 5 % of this management costs can be saved by better management of the assets in a single year, much more money can be saved than the research expenditure estimated.</p>

## ANNEX IV: MODULAR PREFABRICATED PAVEMENTS

<b>1</b>	<b>Project name</b>
	<b>MODULAR PREFABRICATED PAVEMENTS</b>
<b>2</b>	<b>Contribution to NR2C concept</b>
	Reliable Infrastructure and Safe & Smart/Green Infrastructure
<b>3</b>	<b>What's the problem?</b>
	<p>The traditional method of constructing a road surface has gradually acquired an amorphous mixture of qualities that must fulfil a whole range of functions. Over the decades, the hot-rolled asphalt superstructure evolved from providing a comfort layer to being a bearing construction, comfort layer, texture/skid resistance layer, water drainage layer and noise reducing layer in one. This traditional building concept is less flexible in design, construction and maintenance. The functional requirements will vary according to place and time. For example, a silent road is more preferable in some places and at some times than others. For (heavy) goods transport, heavy vehicle traffic makes other demands on comfort and supporting power than private cars. By unravelling the functions and developing specific components or modules for each function, a 'made-to-measure' road surface can be created by stacking the right layers on top of each other, provided that it is easy to exchange the modules. The functional approach behind this concept promotes the use of the right materials for the special requirements of specific components and distinguishes between long lifetime components (low maintenance frequency) and short lifetime components (fast maintenance). The concept of modular building also offers possibilities for the indoor manufacture of components under controlled production conditions, which provide high quality and accelerated introduction of new materials. The assembly of these prefabricated components on site will be less dependent on weather conditions and thus be faster and more flexible than the traditional construction method. Furthermore, prefabrication lends itself very well to incorporating smart devices, such as monitoring the performance of road components.</p>
<b>4</b>	<b>How bad/urgent is the problem?</b>
	<p>The constant increase in the number of road vehicles consequently means, a continuous rise in traffic volumes and axle loads, accelerating developments like congestion, wear and tear of structures and last but not least air pollution and noise emissions. Decisions about expanding the road network taken yesterday should preferably be achieved tomorrow. To minimise downtime of roads for maintenance, the overall quality of the structures must be upgraded. The time slots available for repair and rehabilitation work become closer and closer, requiring faster maintenance techniques. The more traffic, the higher the quality standards required, but also the less construction and maintenance time available and the greater the demand for modular prefabricated structures.</p>
<b>5</b>	<b>Who's the owner of the problem and why?</b>
	<p>In order to receive returns from investments as soon as possible, the application of modular prefabricated building techniques is quite common in the building sector. For road authorities, comparable returns are important: short construction periods, high quality standards and fast maintenance increase the serviceability for the road users. In the case of toll roads, the Concession Company will be the interested party.</p>
<b>6</b>	<b>Expected results of the research?</b>
	<p>New design concepts, new construction and maintenance techniques for pavements, based on the assembly of prefabricated modules will be the main results of the proposed project. This new approach to building road pavements will challenge the industry to develop new materials and components whose properties correspond better with the functional specifications. The final objective will be better, faster and cheaper construction and maintenance of pavements by</p>

	<p>means of a further cost/effectiveness industrialisation of road building processes.</p> <p>The new generation of motorways considers the pavements as a “multi layers” whose structural components and performances features can be selected. Special attention will be paid to the acoustic properties of the surface layer. Furthermore, these new pavements can be equipped with smart components and can be aimed to solve particular tasks such as road and traffic management, pavement performance monitoring, and driver safety.</p> <p>The objectives of the integrated project will consist of the research, design, development, demonstration and validation of:</p> <ul style="list-style-type: none"> <li>• New construction and maintenance techniques and materials for prefabricated large pavement sections.</li> <li>• Smart structural components for monitoring the performance of the construction, the environmental impact of traffic.</li> <li>• Intelligent systems, integrated into the pavement modules for guiding the road users to safe journeys.</li> </ul> <p>Finally, the innovations introduced by the project are:</p> <ul style="list-style-type: none"> <li>• Innovative prefabrication of large pavement sections.</li> <li>• Innovative design methodologies and technologies/issues to model, parameterise and characterise the performance in function of the different layers of the pavements.</li> <li>• Innovative design, development and validation of smart structural components/devices to be applied into construction and maintenance processes and equipments.</li> <li>• Innovative technological/engineered solutions to optimise the cost/effectiveness of the industrial construction and maintenance.</li> </ul>
<b>7</b>	<b>Main users of the results and why?</b>
	<p>The main receptors of the results will be road authorities, users, industry (manufacturers, suppliers and contractors) and research centres. This project will stimulate innovation in the civil engineering sector.</p>
<b>8</b>	<b>Costs/benefits</b>
	<p>The project proposal will focus on research and development of new materials and structural components used for the construction and industrialisation of the new generation of pavements and the use of smart components integrated in the prefabricated structure to monitor their structural and performance features to approach the global management of the motorways.</p> <p>The modular concept of pavements will enable the selection of the optimal combination of structural components and performance features. The structural and operational conditions of the pavements will be monitored by means of intelligent components and monitoring instruments integrated into the material interface. The performance data and information will be processed and integrated into an expert maintenance and management system.</p> <p>The improvement of the acoustic characteristics of the motorway pavements responds to the requirement to reduce the noise level on the road while the major water spill off answers the need to eliminate the aquaplaning phenomena during the useful life cycle and recovery of pollutants.</p> <p>The integrated project is innovative because the technical and scientific approach is based on the development of methodologies, tools and technologies related to optimising the “full life-cycle” for the management and construction of the new generation of pavements.</p>

## ANNEX V: LOW TEMPERATURE ASPHALT

1.	<b>Project name</b>
	<b>LOW TEMPERATURE ASPHALT WITH RECLAIMED ASPHALT</b>
2.	<b>Contribution to NR2C concept</b>
	Green Infrastructure and Safe & Smart/Human Infrastructure
3.	<b>What's the problem?</b>
	<p>In Europe, 320 million tons of asphalt are produced every year for the construction of roads (source: European Asphalt Pavement Association – 2005). Asphalt is produced at high temperatures (160 – 180 °C). Asphalt is produced at high temperatures (160 – 180°C). An average energy of 275 MJoule is needed per ton asphalt, resulting in an energy consumption of 88 billion MJoule for Europe. Asphalt production is therefore a highly energy consuming industry and results in a high CO<sub>2</sub> emissions. In the context of the Kyoto agreement, energy reductions and reductions of CO<sub>2</sub> emissions in production processes are high priority.</p> <p>In recent years several techniques have become available to produce asphalt at reduced temperatures and field trials are being conducted in several countries. The reduction in temperature that can be achieved depends on the technique used: reductions of 30°C to 60°C are technically possible. (For related energy and emission reductions: see 4) The results look promising, but there are still many unsolved questions and challenges. In particular, a crucial point for general acceptance of these techniques by the road authorities is the proof of equivalent performance as hot mix produced mixtures and the possibility of applying these techniques in combination with reuse of old asphalt. As asphalt recycling in asphalt production is very important and common in many countries, it is crucial that these techniques can be combined with high percentages of reuse materials, otherwise the general use of these new techniques will be difficult to accept. Besides the reuse of reclaimed asphalt is interesting from the financial point of view, because the prices of waste deposits have become very high in many countries.</p>
4.	<b>How bad/urgent is the problem?</b>
	<p>The project totally fits into the view of a greener infrastructure. It additionally contributes to a safe and human infrastructure. The problem is important at regional level, national (Kyoto-rules to respect for each country) and international levels (global warming).</p> <ul style="list-style-type: none"> <li>• <b>Green infrastructure:</b> The reduction of production temperatures leads to a decrease of energy consumption, a decrease of CO<sub>2</sub> emissions and a decrease of other harmful emissions. Calculations as well as real trials show that a 40°C reduction in temperature will save at least 14% in energy and consumption of fuel oil and an equal reduction of CO<sub>2</sub>. The application of reclaimed asphalt leads to less consumption and transport of natural resources and a decrease of waste disposal.</li> <li>• <b>Safe infrastructure:</b> A reduction in production temperatures leads to a reduction in the fumes on the work site. This is important for the health conditions of the road workers. Moreover these fumes lead to bad visibility for road users driving on adjacent lanes. A reduction of the fumes will reduce the number of accidents resulting from bad visibility.</li> <li>• <b>Human infrastructure:</b> fewer fumes and fewer emissions lead to a reduction of smells related to asphalt production and laying.</li> </ul>
5.	<b>Who's the owner of the problem and why?</b>
	<p>The new production techniques must be introduced by the asphalt producers in the first place. However, they need support from the road owners to try out and demonstrate the new techniques in practice, while accepting a certain risk of failure related to innovative techniques.</p> <p>The problem addresses many stakeholders:</p>

	<ul style="list-style-type: none"> <li>• Governments: they need new production processes to reduce energy consumption and to reduce CO<sub>2</sub> emissions in companies. They want to make use of reusable materials in constructions and need sustainable infrastructure.</li> <li>• Road authorities: they need the guarantee that equivalent performance can be achieved with the new production techniques and asphalt mixes. They are responsible for the functional specifications of the products.</li> <li>• Contractors: they need possibilities to demonstrate their techniques in practice. It is only through practical experience that they can gather knowledge about the performance of the asphalt mixtures, production techniques and the asphalt layer constructed. Furthermore, a reduction in the production temperature makes it easier to comply with legislation on maximum emissions during production and construction.</li> </ul>
<b>6.</b>	<b>Expected results of the research?</b>
	<p>Research will be performed in the laboratory and on the field. In the laboratory, the necessary know-how will be developed for the type testing (mix design and testing) of these mixes with the required workability, compactibility and performance. This laboratory experience will be up-scaled to large-scale production and field implementation to demonstrate that real production and application is adequate and gives the required performance.</p> <p>More particularly, the following results are expected:</p> <ul style="list-style-type: none"> <li>• recommendations for the design of asphalt mixes including feasible percentages of reclaimed asphalt to be applied,</li> <li>• performance of different low temperature production techniques including the performance of the final products in relation to traditional hot mix asphalt,</li> <li>• recommendations concerning production, laying and compaction</li> <li>• environmental and cost analysis</li> </ul>
<b>7.</b>	<b>Main users of the results and why?</b>
	<p>There are several users depending on the type of the results:</p> <ul style="list-style-type: none"> <li>• Design of asphalt mixes: mainly contractors, but also road authorities who are responsible for correct specifications for the asphalt mixtures.</li> <li>• Impact on performance: mainly contractors, road authorities and/or road owners. Contractors must fulfil performance requirements; road authorities need the guarantee that equivalent performance can be reached with these products.</li> <li>• Recommendations for production and application: contractors, road authorities, notifying bodies or other control instances.</li> <li>• Environmental and cost analysis: (local) governments, road authorities, and contractors.</li> </ul>
<b>8.</b>	<b>Costs/benefits</b>
	<p>The environmental benefits are significant:</p> <ul style="list-style-type: none"> <li>• The reduction of production temperatures of hot mix asphalt means a significant contribution in reducing energy consumption. A 40°C reduction in temperature will save at least 14% in energy and consumption of fuel oil, and reduction of CO<sub>2</sub>.</li> <li>• At lower process temperatures, the amount of harmful fumes is significantly lower at production level. A 40°C reduction in the temperature also reduces fumes by a factor of 8 when laying. This significantly improves the health and safety conditions for the road worker.</li> </ul> <p>Economic benefits:</p> <p>Most of the techniques require additives or special techniques whose prices are comparable with the price of fuel oil. As energy and fuel prices tend to increase with time, it is to be expected that these techniques will become more and more interesting in economic terms.</p>

## ANNEX VI: BRIDGE ECO-ASSESSMENT

1.	<b>Project name</b>
	<b>BRIDGE ECO-ASSESSMENT</b>
2.	<b>Contribution to NR2C concept</b>
	Green Infrastructure mainly, and also reliable
3.	<b>What's the problem?</b>
	<p>In the past, the key word for bridge designing was "resistance". In recent years, in addition to resistance, the introduction of durability concerns has been at the source of an initial important change and a renewed approach to bridge design, from the choice of materials to the choice of the type of structures and detailing. Nowadays, it is clear that sustainability is our newest major challenge! Preserving the environment, saving rare materials, reducing energy consumption are the new targets. Representing 46% of energy consumption and 25% of greenhouse gases, the construction sector has a major role to play. All the actors concerned (material and product suppliers, construction companies, decision makers, bridge owners,) are very aware of this fact. Each of them agrees that sustainable development requires innovation in civil engineering and they are ready to make the necessary changes. Material suppliers for example have already put a great deal of effort into reducing the environmental impact and energy consumption of their activities. The concrete and steel sectors have already launched some environmental assessment approaches for various industrialised products to be integrated in constructions.</p> <p>To be able to move from the level of materials or individual products to a complete structure, taking into account its whole life cycle from erection, and service to dismantling, recycling and ultimately end of life, we need tools and agreed methodologies that will enable us to assess bridges on their whole life from an environmental point of view. Such tools are now being developed and applied for road environmental impact assessment, generally based on life cycle analysis and multi-criteria analysis. With regard to buildings, there is also the HEQ (High Environmental Quality) approach, which still has to be transferred to civil engineering. To accelerate this transfer, it is necessary to:</p> <ul style="list-style-type: none"> <li>• Demonstrate the feasibility of the sustainable approach for each bridge family (concrete, steel,) by making an environmental assessment of various typical solutions of current bridges in Europe and thus identify sources of progress inside each family. Current bridges must be studied because they represent 90% of the total number of bridges and consequently a major environmental and economical weight.</li> <li>• To develop some improved environmental solutions that would also be economically assessed and to check they remain globally competitive.</li> </ul> <p>This approach taking into account environmental criteria will also enable the practical implementation of some very innovative solutions, which are still not currently competitive, if only considering usual costs.</p> <p>Eco-assessment of bridges complies with sustainable requirements for the benefit of society and is a vehicle of innovation, development and competitiveness for the European civil engineering sector.</p>
4.	<b>How bad/urgent is the problem?</b>
	<p>The urgency with respect to the preservation of the environment is clear and needs no further explanation. Moreover, the status of the civil engineering sector, economically and scientifically, underlines the urgency of the problem. Through the innovations and research and development required, the proposed renewed approach to bridge assessment is a unique opportunity to develop an industrial sector which is attractive in terms of employment, well positioned from an economic point of view and which promotes technological progress which responds to new expectations and demands from the users and society. In addition, these are also important</p>

	conditions for maintaining the leadership of European civil engineering faced with increasing international competition.
<b>5.</b>	<b>Who's the owner of the problem and why?</b>
	<p>The main owners of the problem are the road authorities and the contractors. Both are interested in an innovative civil engineering sector. The road authorities must urge the contractors to innovate by selecting tenders not only based on initial costs but also by taking into account the life cycle costs. But it is also the responsibility of the industry to innovate, in order to be able to propose new solutions which are reliable and competitive. Both industries and scientific institutes must develop knowledge and tools that will facilitate the dialogue between road authorities and contractors, and so create the condition of a clear competition. However, only the availability of funds can boost the required research to deliver concrete and practical results for end-users within a few years.</p> <p>A unique advantage of the present period, and another reason for not delaying projects in this field, is that all the actors are now well convinced of sustainability challenges, their respective responsibilities and the benefits of working together. We must take advantage of this excellent climate. European-wide cooperation between public partners, private partners and scientific institutes and governmental support and funding are the key factors to success.</p>
<b>6.</b>	<b>Expected results of the research?</b>
	<p>The expected results of the research are:</p> <ul style="list-style-type: none"> <li>• a methodology for the environmental assessment of different families of structures (concrete, metal, ...)</li> <li>• the implementation on representative examples of current bridges in Europe</li> <li>• analysis of possibilities to improve solutions from an environmental point of view, with an economic assessment in parallel.</li> <li>• implementation of the approach to some very innovative solutions.</li> </ul> <p>Ultimately, the erection of one or two real demonstrative HEQ (High Environmental Quality) bridges. The erection of such bridges would be undoubtedly be a very efficient way of communicating and evaluating the results of the project and convincing both commissioning authorities and contractors that it is possible, and possible in economic conditions.</p>
<b>7.</b>	<b>Main users of the results and why?</b>
	<p>The industry (manufacturers, suppliers and contractors) operating within the civil engineering sector will be the main user of the results of this project. This project will stimulate innovation in the civil engineering sector.</p> <p>The other main users will be bridge owners: the existence of an agreed methodology for bridge eco-assessment will enable them to organise competition on the basis of environmental transparent criteria and to make relative comparisons between the proposed solutions.</p>
<b>8.</b>	<b>Costs/benefits</b>
	<p>The first benefit is expressed in terms of preservation of the environment and the reduction of energy consumption, as a contribution to the effort expected from the construction sector. The second benefit is the development and competitiveness of the civil engineering sector, through knowledge generated, research and innovation.</p> <p>In order to attain the perspective described in the short term, this type of research requires a financial impulse of 1.5 to 2 million Euros per year over a period of four to five years. At the end, a fund support to the erection of HQE bridges can be estimated at: 0.15 million Euro/bridge.</p>

## ANNEX VII: TYROSAFE

1.	<b>Project name</b>
	TYROSAFE – TYre and Road surface Optimisation for Skid resistance And Further Effects
2.	<b>Contribution to NR2C concept</b>
	Save & Green Infrastructure
3.	<b>What's the problem?</b>
	<p>Drivers need grip between the tyres and the road to accelerate, decelerate or change the direction of a moving road vehicle. This grip is provided by the skid resistance properties of the road surface in combination with the friction characteristics of the tyre. This combination is critical for safe driving and many European countries have investigated the correlation of a low skid resistance level with accident hot spots. The result of this research proves that with a sufficiently high value of skid resistance, the safety of roads can be improved and the number of accidents reduced. Skid resistance is therefore a very important characteristic of the road surface affecting safety particularly because it can be improved by the design of the road surfacing.</p> <p>However, although improving the tyre-road interaction to increase skid resistance has positive effects in improving safety, there may be negative effects such as increased rolling resistance and noise emissions. A higher rolling resistance means the use of extra energy to overcome this effect, which could lead to higher fuel consumption and CO<sub>2</sub> emissions. In these times when environmental issues like noise, air quality and energy consumption are becoming increasingly important, any consideration of the safety benefits of improved skid resistance therefore needs to focus on rolling resistance and noise emissions as well.</p> <p>Currently the properties of road surfaces and tyres are not optimised to balance all of these effects. Rather, road engineers or tyre manufacturers concentrate on one or two separate aspects. Knowledge of how these effects interact with each other is very limited. Therefore, optimisation of tyres or road surfaces for one main effect could lead to negative impacts on the other properties.</p> <p>To be able to assess these interdependencies it is necessary to measure the respective values for skid resistance, rolling resistance and noise emission. To accomplish this task, especially for skid resistance and noise, most European countries have developed their own measuring methods. To ensure the comparability of measurement results, a common basis must be created to which the different techniques can refer. In this context, the policies and standards of individual countries relating to skid resistance, rolling resistance and noise emissions vary considerably across the EU.</p> <p>The same is true of the impact of climatic change, since current standards are based on historic responses to national requirements and climatic conditions. The potential effects of climate change, however, could mean that the assumptions on which these standards are based will change. Other measures needed to manage the effects of climate change may also have side effects on the characteristics of road surfaces and the skid resistance that they can provide.</p> <p>Many of these issues have already been addressed and different EU countries have carried out research separately, but there is a need to bring ideas together and establish what scope there is for developing a harmonised approach for the future. This is necessary to ensure increasing safety and greening of transport on European roads and not just at national level.</p> <p>This Coordinating Action will not only focus on the road surface but also on tyres and on the interaction between the road surface and tyres. Only an optimised interaction can lead to a high level of safety for drivers on the roads in European countries while ensuring the most positive greening effect, through reduction of CO<sub>2</sub> output and noise emissions.</p> <p>This project will provide a synopsis of the current state of scientific understanding and its current application in national and European standards. It will identify the needs for future research and</p>

	propose a way forward in the context of the future objectives of European road administrations in order to optimise three key properties of European roads: skid resistance, rolling resistance and tyre/road noise emission.
<b>4.</b>	<b>How bad/urgent is the problem?</b>
	International problem, with high relevance.
<b>5.</b>	<b>Who's the owner of the problem and why?</b>
	<ul style="list-style-type: none"> <li>• Road Authorities/Operators: They have to maintain the roads and ensure provisions for skid resistance</li> <li>• Local Authorities: They have to ensure certain air quality limits.</li> <li>• European Union: They aim to reduce fatalities and reduce negative environmental effects.</li> </ul>
<b>6.</b>	<b>Expected results of the research?</b>
	<p>First of all, coordination of the existing know-how is necessary. The TYROSAFE project does not do any research. The main objectives of the TYROSAFE project are to raise awareness, coordinate and prepare for European harmonisation and optimisation of the assessment and management of essential tyre/road interaction parameters to increase safety and support greening of European road transport. Through the following operational objectives the consortium will work towards achieving this target.</p> <ul style="list-style-type: none"> <li>• Set up a platform and organising workshops/expert working groups <ul style="list-style-type: none"> <li>– to collect and share existing knowledge including past, current and future research activities about skid resistance, rolling resistance and noise emissions,</li> <li>– to raise awareness concerning the safety relevance and greening influence of road surface parameters.</li> </ul> </li> <li>• Study national standards/policies of different EU and neighbouring countries with regard to skid resistance, rolling resistance and noise emissions, document current practice in EU countries, provide recommendations for a common European policy on skid resistance, rolling resistance and noise emissions.</li> <li>• Develop a road map/implementation plan including specific stages for the short, medium and longer term (2010, 2015, 2020) towards the final harmonisation of skid resistance test methods and reference surfaces based on research work.</li> <li>• Create one or more matrices showing interdependencies and environmental effects of the factors that influence road surfaces and tyres in relation to skid resistance, rolling resistance and noise emissions. This matrix will allow knowledge gaps to be identified and indicate the need for future research work.</li> </ul>
<b>7.</b>	<b>Main users of the results and why?</b>
	<ul style="list-style-type: none"> <li>• Road authorities/operators</li> <li>• Local authorities</li> <li>• Policy makers</li> <li>• European Union</li> </ul>
<b>8.</b>	<b>Costs/benefits</b>
	<ul style="list-style-type: none"> <li>• Low costs, as no research infrastructure is needed for a Coordinated Action</li> <li>• Social benefits: improved safety, reduced noise emission, reduced pollution</li> </ul>

## ANNEX VIII: ENERGY CONTROLLED PAVEMENTS

1.	<b>Project name</b>
	<b>ENERGY CONTROLLED PAVEMENTS AND ROADS</b>
2.	<b>Contribution to NR2C concept</b>
	Smart & Safe Infrastructure and Green/Reliable Infrastructure
3.	<b>What's the problem?</b>
	<p>The fact is that roads and pavement constructions literally have to perform in the open air. Consequently, these constructions are exposed to a range of weather conditions leading to a variety of thermal conditions for the road structure and hence to a variety of conditions for the road drivers.</p> <ul style="list-style-type: none"> <li>• In summer, the structures are permanently collecting heat from solar radiation which makes asphalt pavements particularly susceptible to permanent deformations, producing rutting at the road surface. Rutting affects the safety level of the pavements, specifically in the case of rainfall when aquaplaning causes cars to lose control.</li> <li>• In winter, the water penetrating into the road surface layer will become frosted coupled with volume expansion deteriorating this pavement layer (potholes, stripping). The combination of low surface temperatures and cooling down of the air with a high relative humidity will cause white frost and icy road surfaces, affecting the safety of drivers. De-icing products (mostly salts on roads and liquids on airfields) must be used to keep the roads free of ice. However these products have many disadvantages for the environment: contamination of the verges and ditches alongside the road.</li> <li>• The temperature differences between summer and winter, but also between night and day cause expansion and contraction of the road materials. The subsequent stresses and strains affect the fatigue lifetime of the pavement and produce road cracking.</li> </ul> <p>These temperature changes between air and structures take place in a completely uncontrolled way and surprise road authorities again and again. Better control of the thermal condition on pavements will improve the safety, reliability and sustainability of the road networks.</p> <p>Another observation is the increasing energy demand of the road infrastructure for all kind of facilities to support the traffic flows, such as lighting, traffic control systems, intelligent road markings and various communication services (telephones, road sensors, information panels and infrastructure-driver communication). On the other hand, most countries have millions of square meters of pavements in which heat is permanently collected by solar radiation - free energy that slips away because of uncontrolled exchange with the environment through air and soil. For the next decades the challenge will be to recover this thermal energy to supply road and traffic-related facilities with energy and to control the thermal energy of road pavements at the same time.</p>
4.	<b>How bad/urgent is the problem?</b>
	<p>Since road infrastructure is crucial for the economy and mobility of people, it is very important that roads are safe and accessible for road users at any time. Keeping the traffic rolling in all kinds of conditions is one of the major issues of every road authority in all European countries. Controlling the effects of weather on road conditions becomes an essential step forward in preventing unwelcome surprises. In view of the climate change, more extreme conditions can be expected in the near future, so developments to restrict the impact of the phenomena become more and more urgent. In the same context, energy recovery by means of the thermal control of roads and pavements will contribute to the European policy of reduction of the use of fossil fuels. The project supports the political objective of meeting at least 10% of all energy needs from renewable, sustainable sources by the 2010.</p>

<b>5.</b>	<b>Who's the owner of the problem and why?</b>
	<p>The road authorities have to guarantee accessibility of the road network under all weather conditions and are therefore the main owners of the problems. They are also responsible for the functionality and sustainability of the precautions taken to guarantee drivers safety and an acceptable service level of their roads. Controlling the thermal impact of the weather on the infrastructure will delay deterioration of road surface layers and thus reduce the maintenance demand and increase the availability of the network.</p> <p>In view of the climate changes, the whole society is the owner of the problem. Road transport represents 47% of energy consumption and 25% of greenhouse gas emissions. Recovery of sustainable energy by means of adequate thermal energy control of pavements will help meet the environmental targets concerning renewable energy supply. This development will constitute the first step to road networks that will provide their own energy needs.</p> <p>In few of the main ownership of the problem, governments and road authorities must take the lead by starting up this project. They must stimulate and encourage scientists and other stakeholders to find and develop the tools to achieve these energy controlled pavements and roads.</p>
<b>6.</b>	<b>Expected results of the research?</b>
	<p>Full-scale experiments with energy controlling systems and recovery systems have been conducted in some countries over the past few years. These experiments, assembled with generally available components and techniques, have shown various results but have also shown the potential of energy recovery by controlling the thermal conditions of pavements and that it is more than a dream of scientists. Optimising available components and even developing new materials and techniques requires a research impulse to achieve successful and cost effective solutions. Combination with prefabrication of road components will increase the chance of successful results.</p> <p>The project will have the character of fundamental research and requires cooperation with other sciences. The research will start by presenting an overview of all the possible physical and chemical synthesis and techniques. Laboratory tests will establish the effectiveness of potentially suitable techniques and products. Really suitable products and techniques will be demonstrated in a field test to show that energy recovery from pavements can become reality, thus stimulating stakeholders to innovations.</p>
<b>7.</b>	<b>Main users of the results and why?</b>
	<p>Ultimately, the industry (manufactures, suppliers and contractors) operating within the road building and energy recovering sectors will be the main users of the knowledge generated by this project. The project will stimulate innovations in the field of energy control of pavements and recovery energy from roads. The results of the project will open up a completely new market. Furthermore, the discovery of the new function of roads as energy supplier will change the attitude of society towards the presence of roads in their direct neighbourhood.</p>
<b>8.</b>	<b>Costs/benefits</b>
	<p>The annual loss of life of hundreds of car drivers in accidents caused by sudden changes in road surface conditions as a result of changing weather conditions justifies investment in this field of research. Better control of the thermal conditions of road surfaces can help reduce the number of accidents. In this context, it seems as if the insurance companies are the main winners of this research. However, the fewer accidents, the less downtime of the road networks. The road authorities and society are then the beneficiaries. The project results help delay the deterioration of road surface layers. A delay of one year already creates Europe-wide profits of tens of millions Euros per year.</p> <p>The increasing prices of fossil fuels and the aim to replace these resources by sustainable, renewable energy sources will make energy recovery from pavements more and more attractive.</p>

## ANNEX IX: INTEGRATED MODELS FOR URBAN DESIGN

1.	<b>Project name</b>
	<b>INTEGRATED MODELS FOR URBAN DESIGN</b>
2.	<b>Contribution to NR2C concept</b>
	Human Infrastructure and Safe and Smart Infrastructure
3.	<b>What's the problem?</b>
	<p>The public space in urban areas is very popular in the sense that many potential users claim square meters for their specific demands and expectations concerning safety and security. Pedestrians, cyclists, cars, trucks, trams, city dwellers and last but not least the citizens themselves expect facilities and services that meet their daily needs. Integration of this range of functionalities into the generally scarce public space available will be a tremendous challenge for city planners. They face seemingly unsolvable complex problems. What are the best routings for bus and or tram lanes in the city road plans from the humanitarian and engineering point of view and how to incorporate such lanes into the street profile (horizontal integration) warranting the safety of other users of the public space? How to configure this bus lane recognisably with respect to the application of materials and components (vertical integration)? Etc., etc....</p> <p>In brief, the design of cities and their urban infrastructure is essentially concerned with problems connected with the different scales (from road material properties to the shape of cities) and disciplines (from traffic engineers to landscape architects). Tuning all these different but related specifications and conditions is not only very time consuming but also involves possible misunderstandings and miscommunication which affect the quality of the final result of the design process. City planners lack the tools and knowledge to model and tune the relations between all scales and professions of urban design over the complete range from technical problems to planning issues. These relations are essential to the final qualities and performance required by users and owners of urban infrastructure. There is a demand of conceptual and operational tools aiming at:</p> <ul style="list-style-type: none"> <li>• <b>Horizontal integration:</b> on each scale several disciplines (ranging from the humanities to the engineering sciences) are relevant to explain an aspect or part of city life; but each of them uses specific models and vocabularies; these new tools should help produce common and global approaches to each these urban elements.</li> <li>• <b>Vertical integration:</b> to improve the quality and performance of urban designs, it is important to act simultaneously on these various scales in a coherent fashion:             <ol style="list-style-type: none"> <li>1. From the qualities and properties of <b>urban materials</b> to their transformation into geometrical arrangements forming the various <b>spatial components</b> in which citizens evolve: pavements, roads, bus lanes, arcades...</li> <li>2. From these <b>spatial components</b> to their assembly into <b>urban components</b>: streets, plazas, ... that organise the coexistence of the functions and users of a city.</li> <li>3. From these <b>urban components</b> to their assembly into <b>urban patterns</b>: patterns of transport and access, street patterns...</li> </ol> </li> </ul> <p>The “urban” part of NR2C (WP1) has provided the professional community with a set of “global design models”, intended to articulate the various disciplines, knowledge and points of view implied by the design of multi-modal streets. These models are part of a whole set of new concepts, methods and specifications for street design. They describe and explain both how some specific kinds of streets work and achieve special qualities and how actors should cooperate in their design. This research has mostly achieved <b>horizontal</b> integration. Here it is proposed to expand this research in 3 directions:</p> <ul style="list-style-type: none"> <li>• <i>To develop and reinforce the horizontal integration, started in NR2C: to create more numerous <b>design models</b> to give a whole and consistent approach to street design.</i></li> </ul>

	<ul style="list-style-type: none"> <li>• To <b>extend</b> the methodological and conceptual tools at both the <b>upper scale</b> and the <b>lower scale</b> in order to achieve <b>vertical integration</b>: “urban patterns” at the upper scale (new routes and mobility organisation on the scale of the urban fabric) and street materials on the lower scales (new processes, new materials and new geometrical forms, etc.)</li> <li>• To give to this design tool a <b>European dimension</b> by collecting and reuniting in a single web based interface various design models coming from different European countries, organised into a <b>semantic database</b> allowing intelligent navigation.</li> </ul>
<b>4.</b>	<b>How bad/urgent is the problem?</b>
	Today European cities share the same general history, the same global evolutions and face problems that are common to all industrially and technologically developed countries. It is urgent to provide urban designers with powerful tools to develop and share their practices, methods and solutions dealing with multi-modal streets, patterns of streets and the assembly of street materials.
<b>5.</b>	<b>Who’s the owner of the problem and why?</b>
	This problem of producing and integrating common knowledge for the design of streets belongs: <ul style="list-style-type: none"> <li>• To <i>professionals</i> of all the <i>disciplines</i> that analyse the city and its streets from various special points of view.</li> <li>• To <i>users and owners</i> of the infrastructures who are asked to become more and more involved into cooperative design processes.</li> </ul>
<b>6.</b>	<b>Expected results of the research?</b>
	This project, supporting the implementation of robust, well-founded designs for urban areas, should provide: <ul style="list-style-type: none"> <li>• A precise survey on the problems and difficulties encountered at the meeting between different “scales”: for example, what are the limits that architects face in using road materials to compose their street design?</li> <li>• The creation and study of a set of <i>global design models</i> on street elements, extended by a set of models of “street patterns” and “mobility organisations” (upper scale) and by a set of “urban material assemblies” (lower scale).</li> <li>• A web-based tool for organising, interrelating, sharing, choosing, assembling and disseminating these street design models according to their scale and the specific problems they solve (safety, traffic, atmosphere, commercial use, sustainability...).</li> </ul>
<b>7.</b>	<b>Main users of the results and why?</b>
	<ul style="list-style-type: none"> <li>• Owners and policy makers: to make <i>programmes</i> for future street design.</li> <li>• Designers: to create coherent and integrated <i>designs</i>.</li> <li>• Users in participation design consultancies: to offer a shared <i>common language</i>.</li> </ul>
<b>8.</b>	<b>Costs/benefits</b>
	<ul style="list-style-type: none"> <li>• The “vertical integration” of urban design scales will reduce the contradictions between technical solutions, design intentions and urban planning: a certain number of mistakes that usually lead to quite expensive litigations between owners and designers will be avoided by a better coherence of choices belonging to different scales of urban design.</li> <li>• The tool will also be a base for more effective communication between construction partners that will enhance all the processes involved in the production of a street.</li> <li>• More subtle human qualities will be achieved such as sympathy, harmony, good image and vitality, i.e. qualities that cannot be directly expressed in quantitative terms but that obviously contribute to the global social benefits that cities expect from their street design.</li> </ul>

## RECAPITULATIVE LIST OF NR2C DELIVERABLES

available on FEHRL website : <http://www.fehrl.org/nr2c>

WP0 – global concept:

**D03** – New Road Construction Concepts : Vision 2040 *also published by FEHRL*

**D05** - Facing the future - Developments required

*The D05 is reproduced in part A and its appendix of the present final report*

WP1 – urban infrastructure

o Topic 1: multi-modal streets

**D11** – Expectations and needs for innovation in urban roadway – system – A vision for 2040

*It includes conclusions of seminars organised in urban sector in Sept 2004 and January 2005u*

**D12** - Specifications and concepts for the integration of public transit platforms in urban settings

*It explains what is a model design, and how it can be used.*

**D13** – Specifications and preliminary concepts for the design of multi-modal streets

*In addition to D12, it presents the interest of design models for safety problems in complex urban city and develops the implementation of the methodology in Wattrelos city.*

o Topic 2: Ecotechnic Road system

*The following documents are RESTRICTED, if interested, please contact [mluminari@autostrade.it](mailto:mluminari@autostrade.it)*

**D14** - Multi-functional infrastructure feasibility studies and air cleaning model

**D15** – Preliminary design of multi-functional infrastructure

**D16** – Detailed design and pilot study of multi-functional infrastructure

WP2 – interurban infrastructure

**D21** - State of the art on road innovations

**D22** - Concept and design of selected innovations for interurban infrastructure

*This deliverable is based upon separate technical reports respectively dealing with each of the five innovations developed in WP2, completed by a synthesis report.:*

**D22 - Innov 21A** Development of high performance underlayers with low cost materials and high percentage of re-use

**D22 - Innov 21B** Crack-free semi rigid pavement incorporating two industrial by-products

**D22 - Innov 22** Roadway perception technology using the infrared know-how

**D22 - Innov 23** New maintenance technique aiming at enlarging the overall conditions of application

**D22 - Innov 24** Improving the mechanical properties of a low noise section

**D22** – Synthesis Report - Development, Assessment, and Application of Innovations for Interurban Infrastructures

*The D22 is reproduced as part of the part B of the present final report*

**D23** – Concept and research programme for future interurban infrastructures

WP3 - bridges

**D31** – State of the art review – a vision of new bridges

**D32** - New materials properties and modelling

**D33** – Preliminary design of innovative solutions

*D34+35 : Two separate reports have been delivered for the two solutions respectively tested at EPFL and LCPC:*

**D34+35** - Hybrid FRP concrete bridge desk, tested at EPFL

**D34+35** – Composite UHPFRC concrete bridge desk, tested at LCPC

**D45** – Final report

*It is the present document*

Photos

LCPC  
LROP  
Cete de Lyon  
DWW  
EPFL  
FEHRL  
DRI  
KTI  
VTI  
ZAG  
BRRC  
Autostrade  
Eurovia  
JMI



Which are the challenges for the European road infrastructure of the future ? How can innovation deliver solutions ?

NR2C European project develops a long term vision, reflecting society's perception of road infrastructure in 2040, linked to short and medium-term actions. Based on four key concepts, it identifies research required in the field of road engineering to guarantee comfortable and reliable ground transport in a sustainable and environmental-friendly way.

Examples of innovations developed in NR2C, answering to these concepts are presented:

- towards more human infrastructure : new design-models for arrangement and development of multi-modal streets, that can be used as a tool for dialogue and co-design between actors
- towards greener infrastructure : Eco-Road System - an integrated road concept, combining new technologies for the reduction of traffic nuisance (noise, air and water pollution) ; the use of recycling to preserve rare resources;
- towards more reliable infrastructure : new maintenance road processes; innovative industrial small and medium span bridges.
- towards safer and smarter infrastructure: the infra-red technology to improve drivers' vision under bad weather conditions, etc.

Finally, face to developments required few critical projects are recommended to provide the sector with new basic knowledge standards for trend-setting developments needed to face the future with confidence.

