



INTERNATIONAL ROAD MAINTENANCE HANDBOOK

PRACTICAL GUIDELINES FOR RURAL ROAD MAINTENANCE



Volume II of IV Unpaved roads

Financed and coordinated by





Revised by R C Petts of **Intech Associates, UK**
with the financial support of **ODA** (now **DFID**)

under assignment to

TRANSPORT RESEARCH LABORATORY, UK

as a development of the **UN ECA**
handbooks prepared by joint cooperation
of the governments of **FRANCE,**
GERMANY and the **UNITED KINGDOM**
and first published in 1982

Second Edition 1994

Third Edition 2006



© WORLD COPYRIGHT RESERVED
Extracts from the text may be reproduced
provided the source is acknowledged as follows:
PIARC Road Maintenance Handbook



This English version published by
Transport Research Laboratory, UK

ISBN Volume II (Third edition): 0-9543339-9-3





PREFACE (to Third Edition)

This Third Edition of the IRM Handbook is substantially the same as the 1994 Second Edition, but has been printed in a landscape format chosen to reduce the number of pages and make the document easier to use. The new spiral binding allows the handbook to be laid open on a flat surface for easy reference or photocopying. The opportunity has, however, been taken to make minor amendments to the text and diagrams in order to correct errors in the earlier edition.

Transport Research Laboratory, 2006.





II-ii







FOREWORD (to Second Edition)

The road transport network of any country plays a vital role in its economy, and the physical condition of its infrastructure is critical. Without adequate and timely maintenance, highways and rural roads alike inexorably deteriorate, leading to higher vehicle operating costs, increased numbers of accidents, and reduced reliability of transport services. When repair work can no longer be delayed it will often involve extensive rehabilitation, and even reconstruction, costing many times more than simpler maintenance treatment carried out earlier. The need to protect the existing network and keep it in good condition is paramount, often taking precedence over new investment.

PIARC has been in the forefront in promoting this message and in drawing attention to the dangers of neglect. The matter has become increasingly important in recent years for all the highways of the world, but especially so for those in developing countries where there is constant pressure on slender budgets and, in many, an urgent need to cater for growing traffic loads and volumes.



In the late 1970s, the aid ministries of France, the Federal Republic of Germany and the United Kingdom joined forces to produce a 'Road Maintenance Handbook' for maintenance foremen and workers in Africa. Published in 1982 under the auspices of the Economic Commission for Africa, the three volumes - in French and English - soon became widely known and used. By the end of the decade their use had spread far beyond Africa, and their straightforward instructions were being used for training purposes as well as for on-the-job guidance in many countries. The need to reprint provided the opportunity to review the contents in the light of experience and make them more suitable for the wider audience now commanded. PIARC's Committee on Technology Transfer and Development, formerly the Committee on Roads in Developing Regions, undertook to help with this review, which was generously funded by the UK Overseas Development Administration. A sub-committee was established, embracing the three original donor countries, other developed and developing countries, and the World Bank. Although much of the original text has been retained, the new handbooks incorporate more information on labour and tractor-based techniques, and on the development of manpower management and the all-important question of safety at work. The range of maintenance problems addressed has been extended to strengthen their international appeal.



The past ten years have seen major reforms in the general thrust of maintenance policy and in its organisation, management and execution. These changes will continue, and PIARC will play its part along with other institutions in encouraging the process and pressing for further progress. Only a full appreciation of maintenance at the highest levels of policy-making and financial planning can ensure success. But these handbooks have a humbler task-to ensure that the men and women at the operational level are suitably skilled and trained and are using the appropriate tools and techniques, and have interest and motivation in their work.



PIARC has been proud to nurture this project to the point where the new handbooks are available, but its involvement will reach far beyond that. It will provide the necessary international framework within which the handbooks can be translated and printed in many languages. Its worldwide membership of key figures in the national provision and management of highways will assist with their dissemination, ensuring that they find their way into the most appropriate hands in both the public and private sectors. Collectively, these hands will play a fundamental part in sustaining the vital asset which our roadway networks truly represent.

Victor J Mahbub,
President of PIARC
1994





CONTENTS

FOREWORD	iii	Part B - LABOUR BASED RESHAPING	35
INTRODUCTION	ix	1. THE TASK	38
Part A - GRADING	1	2. DEFECTS	39
1. THE TASK	3	METHOD A: ROUTINE RESHAPING	40
2. DEFECTS	5	3. RESOURCES	40
3. RESOURCES	7	3.1 PERSONNEL	40
3.1 PERSONNEL	8	3.2 PLANT AND TOOLS	41
3.2 PLANT AND TOOLS	9	3.3 SIGNS AND SAFETY EQUIPMENT	42
3.3 SIGNS AND SAFETY EQUIPMENT	11	4. MAINTENANCE METHOD	43
4. MAINTENANCE METHOD	13	4.1 PRELIMINARY TASKS	43
4.1 PRELIMINARY TASKS	13	4.2 EXECUTION OF THE WORK	44
4.2 TEMPORARY SIGNPOSTING	15	METHOD B: MAJOR RESHAPING	45
4.3 GRADING THE RUNNING SURFACE	16	5. RESOURCES	46
4.4 GRADING DITCHES	29	5.1 PERSONNEL	46
4.5 COMPLETION AND REMOVAL OF TEMPORARY SIGNS	32	5.2 PLANT AND TOOLS	47
4.6 WORK REPORT	33	5.3 SUPPORT AND SAFETY ARRANGEMENTS	48
		6. MAINTENANCE METHOD	49
		6.1 PRELIMINARY TASKS (as necessary)	49
		6.2 TEMPORARY SIGNPOSTING	50
		6.3 EXECUTION OF THE WORK	51
		6.4 COMPLETION AND REMOVAL OF TEMPORARY SIGNS	59
		6.5 WORK REPORT	60





Part C - DRAGGING 61

1. THE TASK 63

2. DEFECTS 64

3. RESOURCES 65

3.1 PERSONNEL 65

3.2 PLANT AND TOOLS 66

3.3 SIGNS AND SAFETY EQUIPMENT 69

4. MAINTENANCE METHOD 70

4.1 PRELIMINARY TASKS 70

4.2 WORKING WITH A TRACTOR AND DRAG 72

4.3 DRAGGING WITH GRADERS 75

4.4 WORK REPORT 80



Part D - PATCHING 81

1. THE TASK 83

2. DEFECTS 84

METHOD A: MOBILE GANG 86

3. RESOURCES 86

3.1 PERSONNEL 86

3.2 PLANT AND TOOLS 87

3.3 MATERIALS 89

3.4 SIGNS AND SAFETY EQUIPMENT 90

METHOD A: MOBILE GANG 92

4. MAINTENANCE METHOD 92

4.1 PRELIMINARY TASKS 92

4.2 TEMPORARY SIGNPOSTING 95

4.3 EXECUTION OF THE WORK 97

4.4 COMPLETION AND REMOVAL OF
TEMPORARY SIGNS 102

4.5 WORK REPORT 104



METHOD B: LABOUR BASED 105

5. RESOURCES 106

5.1 PERSONNEL 106

5.2 PLANT AND TOOLS 107

5.3 MATERIALS 108

5.4 SIGNS AND SAFETY EQUIPMENT 109

6. MAINTENANCE METHOD 110

6.1 PRELIMINARY TASKS 110

6.2 EXECUTION OF THE WORK 111





Part E - REGRAVELLING (mechanised)	113	Part F - REGRAVELLING (Labour and Tractors)	139
1. THE TASK	115	1. THE TASK	142
2. DEFECTS	116	2. DEFECTS	143
3. RESOURCES	117	3. RESOURCES	144
3.1 PERSONNEL	117	3.1 PERSONNEL	144
3.2 PLANT AND TOOLS	118	3.2 PLANT AND TOOLS	146
3.3 MATERIALS	121	3.3 MATERIALS	147
3.4 SIGNS AND SAFETY EQUIPMENT	122	3.4 SUPPORT AND SAFETY ARRANGEMENTS	148
4. MAINTENANCE METHOD	125	4. MAINTENANCE METHOD	149
4.1 PRELIMINARY TASKS	125	4.1 PRELIMINARY TASKS	149
4.2 TEMPORARY SIGNPOSTING	128	4.2 TEMPORARY SIGNPOSTING	152
4.3 EXECUTION OF THE WORK	129	4.3 EXECUTION OF THE WORK	153
4.4 COMPLETION AND REMOVAL OF TEMPORARY SIGNS	136	4.4 COMPLETION AND REMOVAL OF TEMPORARY SIGNS	165
4.5 WORK REPORT	138	4.5 WORK REPORT	166

INDEX OF VOLUME II	169
ACKNOWLEDGEMENTS	171





II-VII





INTRODUCTION

THE HANDBOOK

This is a guide for the **maintenance foreman or supervisor** assigned to bitumen or unpaved roads in tropical and moderate climates. The objective of the HANDBOOK is to assist him in all aspects of his work whether carried out by direct labour or by contract. Its format enables the volume relevant to the day's work to be easily carried and consulted on site. The HANDBOOK should be his ready reference book. The text is concise and well illustrated. A quick reference should be all that is necessary.

This HANDBOOK does not include a course of study or discuss underlying causes of defects. Inspections, material sources, specifications and testing are also outside its scope. Furthermore it is sufficient here to remind the foreman that his plant and vehicles should be well maintained without telling him how to do it.

Even though the HANDBOOK is intended for use by the maintenance foreman, it will also be useful reading for the engineer or senior supervisor. This will make him more conscious of his duties towards the foreman and enable him to ensure that the maximum benefit is obtained from the HANDBOOK. Each supervisor must understand his responsibility and the part he has to play.

The HANDBOOK can also be used in training centres. With the assistance of country-specific supplementary information, photographic slides, models, and other supporting material, it will be a valuable tool for the trainer and can be distributed to students.

Road maintenance requires a range of organisational and technical skills and the work on roads in use by traffic makes the work potentially hazardous to both the workmen and road users.

It is therefore **essential** that appropriate formal and on-the-job training is given to each category of personnel involved in road maintenance activities to achieve efficient and safe operations.

The foreman usually has an important role in the initial and ongoing training of personnel.

Roads are an enormous national investment and require maintenance to keep them in a satisfactory condition and ensure safe passage at an appropriate speed and with low road user costs.

Late or insufficient maintenance will increase the ultimate repair costs and raise road user costs and inconvenience, and reduce safety.

Road Maintenance is therefore an essential function and should be carried out on a timely basis.

There is a diversity of maintenance activities, the class and type of the road, the cross section to be maintained, the defects recognised, and the resources available. However the general methods proposed here for each activity (with some exceptions) are given under the following headings:

- The task
- Defects
- Resources
- Maintenance method





Where appropriate options are shown for carrying out the work by:

- i Heavy Equipment,
- ii Tractor based methods, or
- iii Labour based methods.

The decision on which method to be used should be made by the engineer or senior supervisor based on considerations of resources available, cost, policy etc.

Maintenance operations are usually grouped in each country according to planning, organisational and funding arrangements. They can normally be categorised as either ROUTINE or PERIODIC.

For the purposes of this HANDBOOK the following grouping is used.

ROUTINE: Operations required to be carried out once or more per year on a section of road. These operations are typically small scale or simple, but widely dispersed, and require skilled or un-skilled manpower. The need for these can, to a degree, be estimated and planned and can sometimes be carried out on a regular basis.

PERIODIC: Operations that are occasionally required on a section of road after a period of a number of years. They are normally large scale and require specialist equipment and skilled resources. These operations are costly and require specific identification and planning. In this handbook PERIODIC also includes certain improvement works such as thin bituminous overlays.

From time to time urgent or emergency works of any nature may be required and these are dealt with as the need arises.

The HANDBOOK consists of 4 separate volumes:

VOLUME I – MAINTENANCE OF ROADSIDE AREAS AND DRAINAGE

- PART A - List of Terms
- PART B - Works Management and Safety
- PART C - Roadside Areas
- PART D - Drainage

VOLUME II – MAINTENANCE OF UNPAVED ROADS

- PART A - Grading
- PART B - Labour Based Reshaping
- PART C - Dragging
- PART D - Patching
- PART E - Regravelling (Mechanised)
- PART F - Regravelling (Labour and Tractors)





VOLUME III – MAINTENANCE OF PAVED ROADS

- PART A - General Repairs
- PART B - Surface Dressing (Mechanised)
- PART C - Resealing Options
- PART D - Thin Overlays

VOLUME IV – MAINTENANCE OF STRUCTURES AND TRAFFIC CONTROL DEVICES

- PART A - Bridges
- PART B - Traffic Control Devices



VOLUME II

Each Part A, B, C, D, E, and F describes tasks concerning **unpaved roads***.

An unpaved road can be a track which has developed with use over a number of years or it can be a purpose built road that has a properly designed and engineered alignment, cross section and drainage. **Earth roads** are constructed using the natural soil found on the route. **Gravel roads** are surfaced with a layer of material which is stronger than the natural in situ soil.

With proper maintenance, an unpaved road can provide a good level of service for traffic volumes up to several hundred vehicles per day. The two main purposes of maintenance are to repair or reduce the damage caused by the combination of the weather and traffic, and to provide a smooth passage for vehicles.

The first objective of unpaved road maintenance is to keep the road in such a condition that it sheds water quickly. If the road does not shed water, the surface will become soft, and ruts and pot-holes will quickly appear. In this way earth roads can soon become impassable.

PART A - GRADING

Maintenance is needed to restore a good camber* on the road to enable water to drain off quickly. This is best achieved by regular

NOTE - Terms with an asterisk are defined in List of Terms (See Volume I - Part A).





grading. On gravel roads, grading is also needed to restore gravel from the shoulders which has been lost from the road surface, to fill pot-holes and corrugations.

PART B - LABOUR BASED RESHAPING

The road camber can also be restored by **labour based reshaping**. This is a viable option when grading equipment is too expensive or not available.

PART C - DRAGGING

In dry areas, **dragging** the road surface may be effective in providing a smooth passage for vehicles and in controlling the formation of corrugations. The object is to correct minor defects on the road surface. Dragging may be carried out with a motorgrader, towed grader or with a drag towed by a tractor or other vehicle.

PART D - PATCHING

Holes in the road may need to be patched. **Patching** can be carried out by a mobile gang or by labour based road attendants.

PART E - REGRAVELLING (Mechanised)

As the surface of a gravel road wears away, new gravel must be added before rapid deterioration of the surface starts. **Regraveling** may also be needed to correct other defects when these become severe, and may also be used to improve an engineered earth road to a gravel road.

PART F - REGRAVELLING (Labour and Tractors)

This option avoids the need for heavy equipment. Tractor haulage of gravel can be economical for distances up to about 10 km with labour used to excavate, load, unload and spread the gravel.

NOTE: In many countries women carry out road maintenance tasks and supervisory duties. The use of male descriptions and diagrams in this handbook is for convenience only. The guidelines are applicable whether the work is carried out or supervised by men or women.





Part A GRADING



11-1



PART A - GRADING



II-2





PART A - GRADING

1. THE TASK



The task is to improve earth and gravel roads by **grading** the existing surface material. **Grading** is normally a ROUTINE MAINTENANCE task. It is carried out by self propelled or towed graders.

The object is to restore the **camber*** by returning material from the sides and shoulders towards the centre of the road. This will enable water to drain off easily.



* See List of Terms, Volume I.





PART A - GRADING



Rollers should be used to compact* the road after grading whenever possible as this will improve the initial quality of the reshaped surface.

Work is best scheduled to follow a period of rain, as the moisture in the material will greatly help compaction by rollers or traffic. For some materials the addition of water can be justified.



Grading can also be used to restore the shape of shoulders, ditches and turnouts (see also Volume I).

* See List of Terms, Volume I.





PART A - GRADING

2. DEFECTS

Grading is used to correct

- Loss of shape

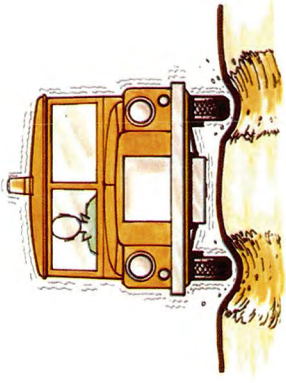

- Ruts

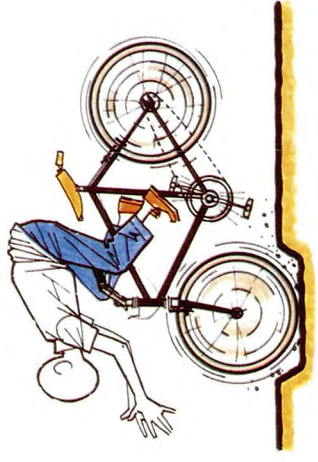

- Potholes





PART A - GRADING

■ **Corrugations**



■ **Erosion Gullies**



■ **Silted or Blocked Ditches**





PART A - GRADING

3. RESOURCES

These comprise personnel, plant and tools, signs and safety equipment.

Grading is a fast moving activity often carried out at long distances from the equipment base. Although it may be carried out by individual graders or towed graders, it is best organised using mobile units of 2-3 grading machines with arrangements for temporary overnight accommodation.

This reduces travelling time between base and worksites and eases supplies and mechanical support problems.

The number and types of grading machines, rollers, watering equipment, and mobile accommodation depend on the:

- road condition (light or heavy grading),
- moisture conditions,
- compaction requirements,
- organisational requirements,
- accommodation arrangements,
- resources available.





PART A - GRADING

3.1 PERSONNEL

The categories and numbers of personnel depend on the equipment resources used. Each grading gang should include:

■ **Supervisors**

- 1 foreman.

■ **Plant Operators and Drivers**

- 1 operator for each motor grader,
- 1 driver for each tractor,
- 1 operator for each towed grader,
- 1 light vehicle driver,
- 1 operator for each motorised roller,
- 1 driver for each water tanker.

■ **Work Force**

- 1 machine attendant for each item of plant and equipment,
- 1 mechanic for daily servicing and minor repairs.





PART A - GRADING

3.2 PLANT AND TOOLS

■ **Motor Graders**

Motor graders of 100 hp (75 kW) or more can be used for light or heavy grading.

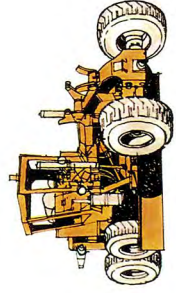

■ **Heavy Tractors and Towed Graders**

100 hp (75 kW) 4WD* tractors and heavy (5 tonne) towed graders can be used for light or heavy grading.

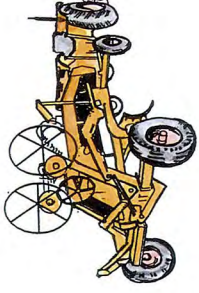

■ **Light Tractors and Towed Graders**

50 hp (38 kW) tractors and light (2 tonne) towed graders can be used for light grading.

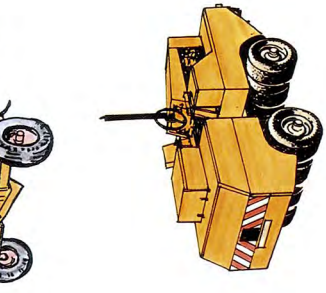

■ **Rollers**

1 or 2 rollers, if available. Rubber tyred rollers are preferred. They can be self propelled or tractor drawn.



* See List of Terms, Volume I.





PART A - GRADING

■ **Water Tankers**

When water tankers are needed and available, the number required will depend on the distance that water has to be hauled. These should be fitted with a spray bar.



■ **Water Pump**

A separate water pump will be needed if none is fitted to the water tankers. The pump should be of sufficient capacity to fill the tankers quickly.

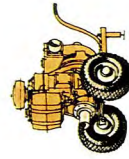

■ **Caravan**

If the mobile units stay away from base overnight and no accommodation is available, caravans or tents could be used.



■ **Other Vehicles**

Transport for the supervisor.



■ **Tools**

Camber board* made as shown from 20 mm treated plywood or hardwood to give a 1 in 20 (5%) slope and carried on the grading machine.

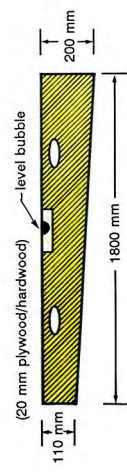

(20 mm plywood/hardwood)
level bubble

110 mm

1800 mm

200 mm

* See *List of Terms, Volume I.*





PART A - GRADING

3.3 SIGNS AND SAFETY EQUIPMENT

The following items should be used where possible.

- **Traffic Signs**
 - 2 'Men Working' signs,
 - 2 'End of Restriction' signs.

These should be **clean** and in good condition.



2



2



■ **Clothing**

Yellow or orange coloured safety vests or safety harnesses should be worn by the machine attendants.

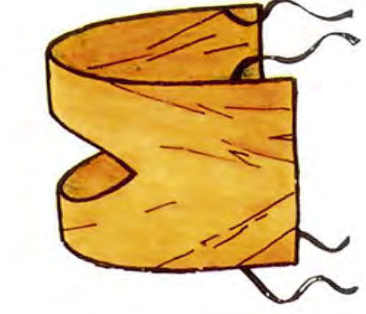



PART A - GRADING

■ **Vehicles**

The grading equipment should be painted yellow or orange and should carry red and white striped marker boards front and rear.

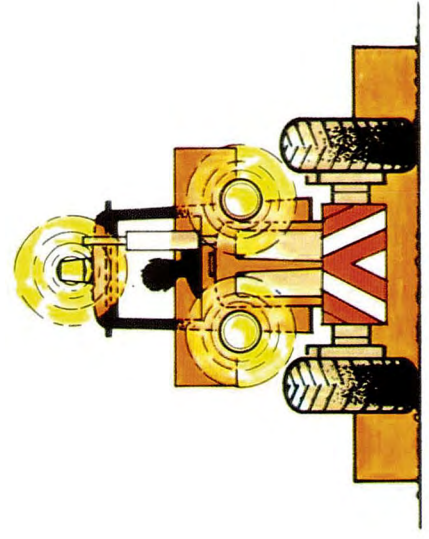

■ **Lights**

The grading equipment should work with headlights switched on and, where possible, yellow flashing warning lights.

■ **Flags**

If yellow flashing warning lights are not available, vehicles and equipment should carry a yellow or orange flag.

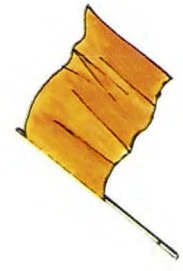



PART A - GRADING

TYPICAL WORKSHEET

4. MAINTENANCE METHOD

GRADING

4.1 PRELIMINARY TASKS

Worksheet No: _____ Date: _____
 District: _____
 Zone: _____ Gang: _____

Road No: _____ from _____ to _____

Section from km _____ to km _____ in _____ m width

Light Grading Watering
 Heavy Grading Compaction

EQUIPMENT TO BE USED:

Motorgraders: _____
 Tractors: _____
 Towed Graders: _____
 Tankers/Bowsers: _____
 Rollers: _____
 Caravans: _____

- The **worksheet** will indicate the location and extent of the work to be carried out, the time, equipment and personnel required for the job.





PART A - GRADING

Before setting out to start the job, a check should be made to ensure that everything needed is ready.



- **Plant and machinery** must be checked mechanically, greased and fuelled. The oil and water levels must be checked.

- Arrangements must be made to **refuel** the plant on the job if necessary. This may be with a refuelling truck visiting the working site, or with an arrangement to refuel at a maintenance or temporary camp.



- **Traffic signs** and **camber board** must be obtained, loaded on the grading equipment and taken to site. These must be properly stored/secured on the grading equipment.



- If the grading crew is staying away overnight, arrangements must be made for accommodation, supplies, etc.





PART A - GRADING

4.2 TEMPORARY SIGNPOSTING

Before work starts, warning signs must be placed at each end of the work area to ensure the safety:

- of the road users,
- of the personnel and plant to be deployed on the site.

Signs must be placed in the following order:

- 'Men Working' signs should be placed at the approaches to the work area.
- 'End of Restriction' signs should be placed at the end of the work area.

Work should **not** be carried out at **night**.

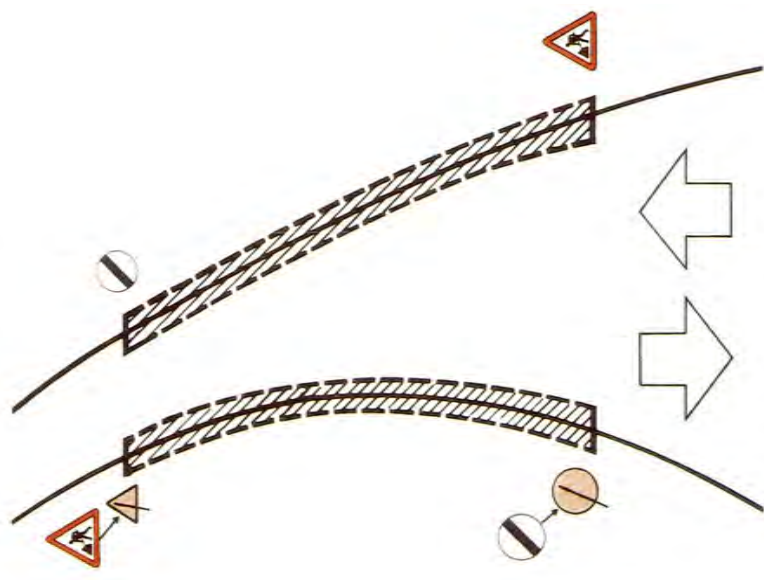

NOTE: SHOWN FOR DRIVING ON THE RIGHT



PART A - GRADING

4.3 GRADING THE RUNNING SURFACE

■ Preparation

Patching (Part D) of large potholes or depressions should be carried out in advance of the grading.

Areas of standing water should be drained. This preparation will ease the work and make the resulting surface last longer.

■ Scarifying*

It may be necessary to scarify the existing surface to cut to the bottom of any surface defects and loosen the material for reshaping.

■ Machine Attendants

These help direct traffic and grader turning, and remove large stones and other unwanted material from the path of the grader.

■ Grading

The grader works on one side of the road at a time and works in passes* about 200 metres long to convenient and safe turning points.

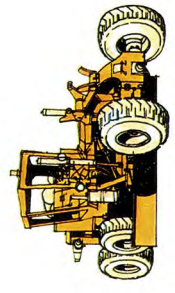
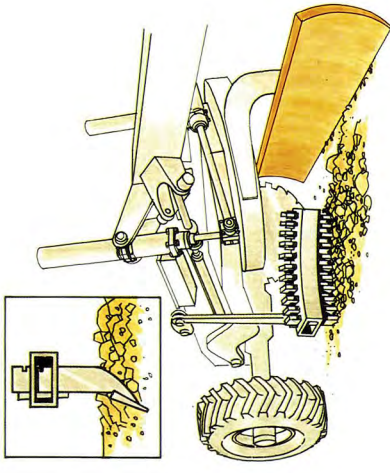

* See List of Terms, Volume I.





PART A - GRADING

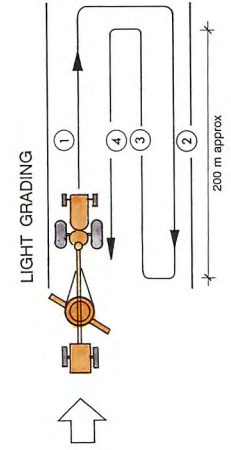

Light Grading will normally require 4 passes to reshape the road.

Heavy Grading will require additional passes to achieve the required camber. Work should be completed on one side of the road at a time.



An **even** number of passes should be used to avoid a flat finished crown*.

Normally initial cutting passes* are required to bring material in from the edges of the road. Spreading passes redistribute the material away from the crown.

* See List of Terms, Volume I.





PART A - GRADING

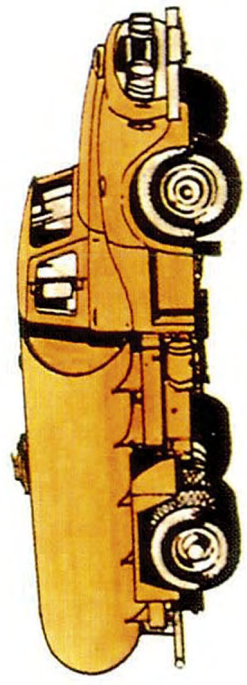

The **initial passes*** cut to the bottom of the surface irregularity and deposit a windrow* just beyond the centre line.

The **water tanker** sprays the windrow with water, if required.

The **windrow** is spread back across the road depositing all the material to give the correct camber*.

A second application of water may be required to obtain the correct moisture content for compaction.

* See List of Terms, Volume I.



PART A - GRADING

The aim should be to develop a proper **crown*** on the road.

The road should be cambered to fall away from the crown at a rate of about **6 to 7 cm** for each **metre** from the centre of the road before compaction. This should achieve a crossfall of about **4 to 6 cm per metre** (4 to 6%) after compaction.

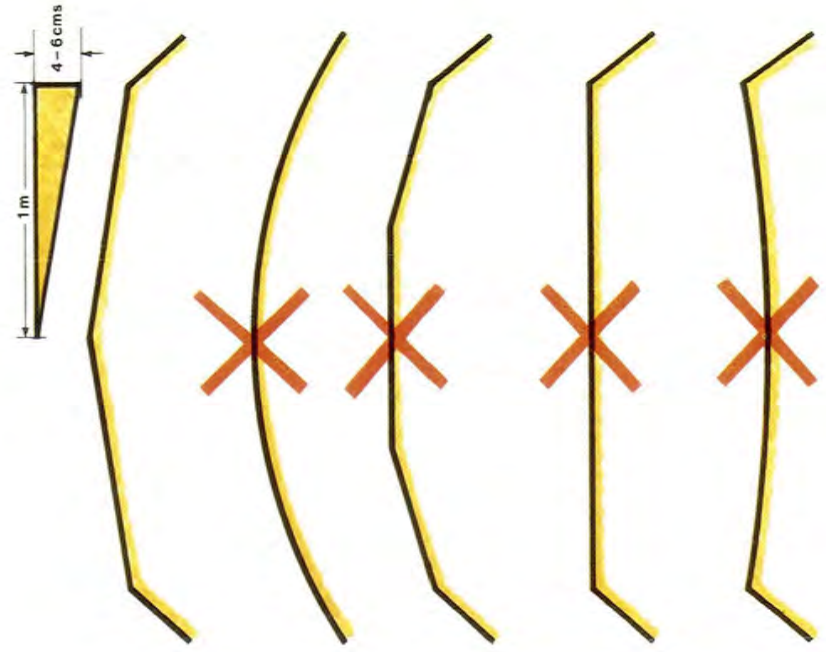

If there is insufficient camber*, water will not drain easily from the surface of the road, potholes will form and the road will deteriorate quickly. This is particularly important on gradients, where the rain water tends to run along the road forming erosion channels.

* See List of Terms, Volume I.





PART A - GRADING

- Do **not** make a final pass down the centre of the road with the grader blade horizontal.



This flattens the centre of the road and causes water to pond leading to rapid deterioration of the surface.

- Do **not** leave a windrow on the road overnight as this is a danger to traffic.





PART A - GRADING

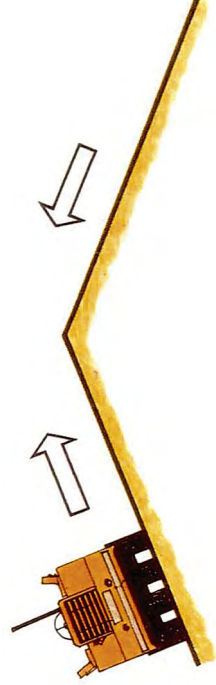

- **Compaction**
When compaction* plant is being used, it must follow close up behind the grader, but only on sections where grading has been completed. About eight passes* of a roller will be needed to achieve full compaction, working towards the centre of the road.
- **Shoulders** are treated as part of the running surface.
- **Junctions and Bends**
Graders must not stop near junctions or bends where they will be a danger to traffic.



* See List of Terms, Volume I.





PART A - GRADING

■ Check the Camber

Camber should be checked with a camber board at about 100 metre intervals along the road.

To use the **camber board*** place it on its edge across the road with the shorter end pointing towards the centre line.

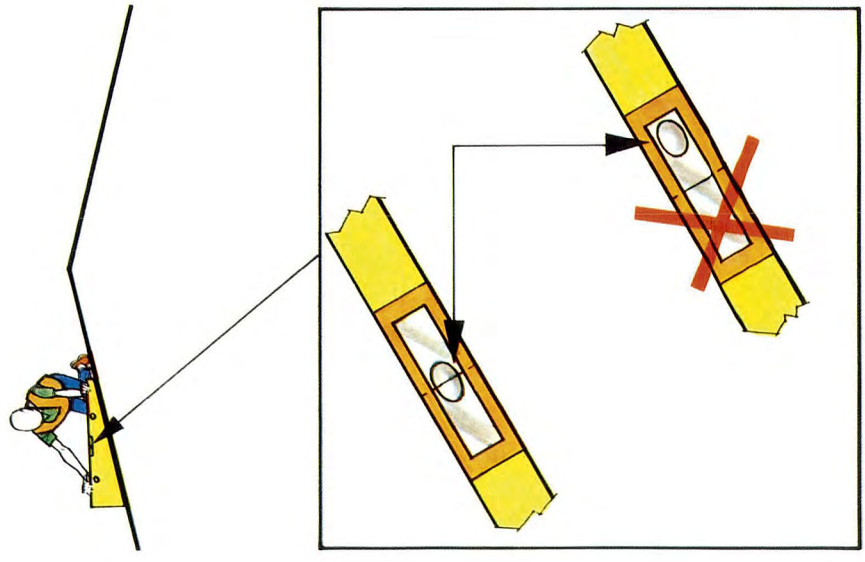

Check the level bubble.

If it is central, the camber is correct.

If it is not central, the camber is either too steep or too flat and further grading and compaction are required.

* See List of Terms, Volume I.





PART A - GRADING

- On bends the surface must be straight (at 4-6%) from shoulder to shoulder with the outer shoulder higher. This is called **superelevation**.

Any crown on a bend can be very dangerous to traffic.

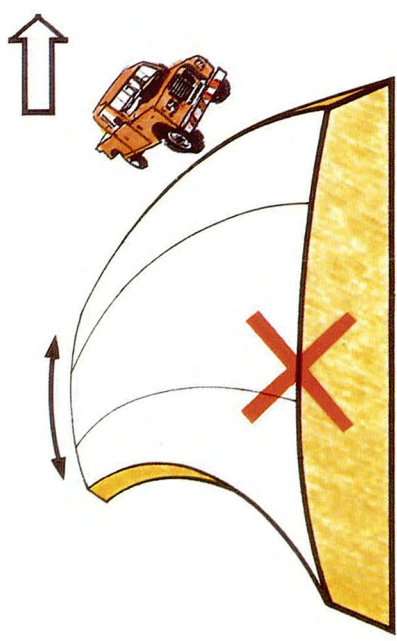
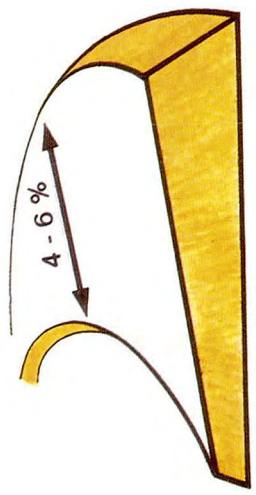



PART A - GRADING

The superelevation must be retained for the complete length of the bend.

On the **transition** at each end of the bend into the straight sections, the superelevation should be gradually reduced until the normal cross section shape with **1 in 20 (5%) camber*** is obtained again.

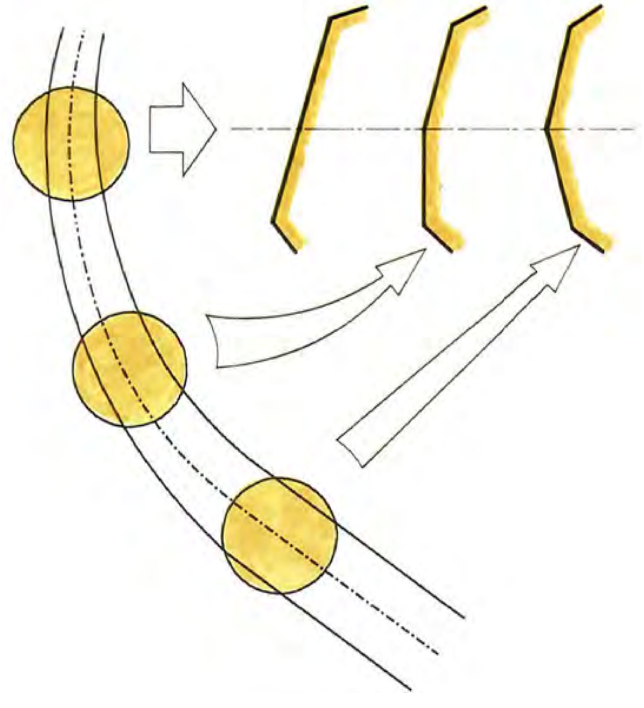

* See List of Terms, Volume I.





PART A - GRADING

- The shape of the road must be maintained over **culverts** to avoid a hump. Material should be brought in if necessary from either side of the culvert to maintain a cover to the top of the culvert of at least 3/4 culvert diameter.
- **Bridge decks** should be kept free from gravel. Loose material should be swept away by the attendants.

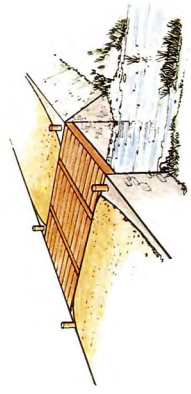
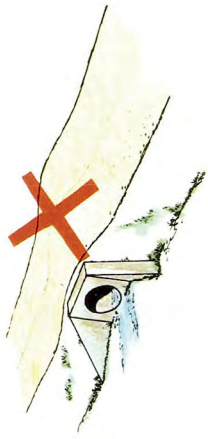

It is important to have smooth approaches to the bridge. They should be smoothed out using the back of the blade with the grader working in reverse, or by hand.

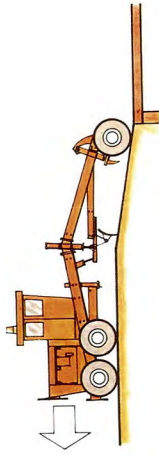



PART A - GRADING

- For most **grading** work, the cutting blade is set to be vertical.
- For cutting **hard** surfaces, the cutting blade should be set back at the top to give the most effective cutting angle.
- For **spreading**, the cutting blade should be set forward at the top.

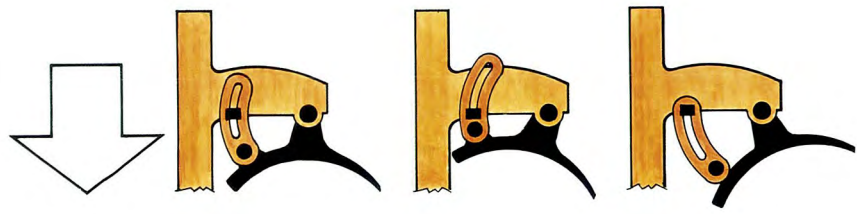



PART A - GRADING

■ To form a **windrow***

Point all wheels straight ahead and angle the blade.

The angle should be sharp enough to let surface material roll freely off the end of the blade.

Travel forward slowly in low gear keeping the blade level and 5-10 cm into the surface material.

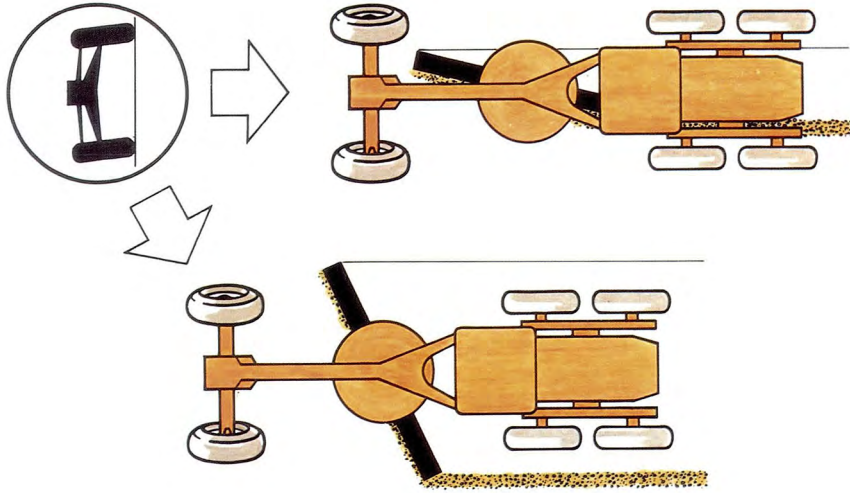

On graders with this facility lean the front wheels in the same direction as the windrow to help counter side thrust on the blade.

The windrow must be formed outside or between the rear wheels.





PART A - GRADING

■ Handling a windrow

Angle the blade to left or right according to the job requirement.
The angle should allow material to roll freely off the end of the blade.

To move or mix material:

- Travel forwards slowly in low gear.
- Pick up material from one side of the machine and pass it to the other.

TRY TO MATCH THE GEAR AND SPEED TO THE WORK TO BE DONE.

To get more power:

- Angle the blade towards the windrow.
- Lean the front wheels against the side thrust.

THE REAR WHEELS SHOULD NOT BE ALLOWED TO RUN OVER THE WINDROW.

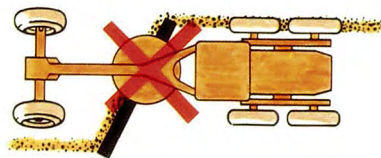
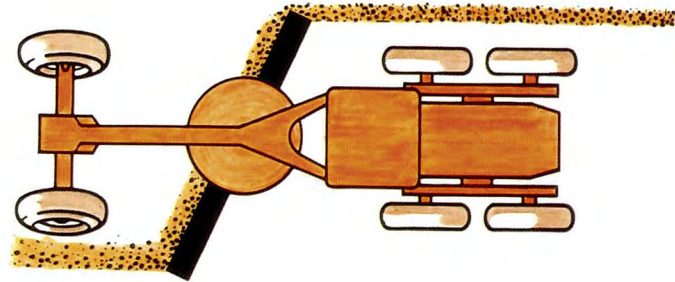



PART A - GRADING

4.4 GRADING DITCHES

Before the road surface is graded, the side ditches must be cleaned.

- Narrow flat-bottomed ditches are not well suited to maintenance by grader. These are best cleaned out by hand. This work is described in **Volume I**.
- Graders should be used to maintain V-shaped ditches and wide flat-bottomed ditches.
- Material from the ditch **should not normally be graded onto the running surface**. In certain circumstances the engineer may instruct the recovery and mixing of the ditch material, where the running surface lacks suitable fines present in the ditch.

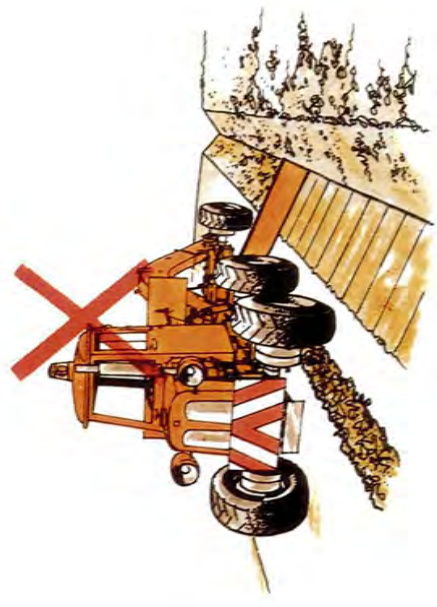



PART A - GRADING

- The first pass* cleans the side slope near the road and windrows the material to the bottom of the ditch.
- On wide flat-bottomed ditches, the second pass cleans the ditch bottom.
- The next pass cleans the ditch back slope and removes the material to the top of the ditch.
- If possible, a third pass is used to push the material away from the edge of the ditch, to prevent it washing back.

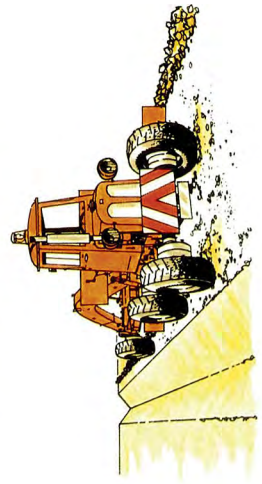
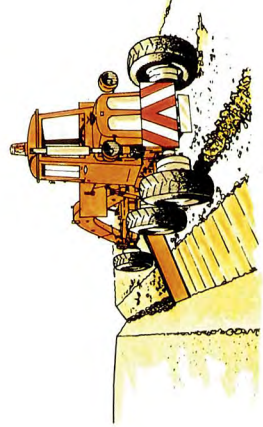
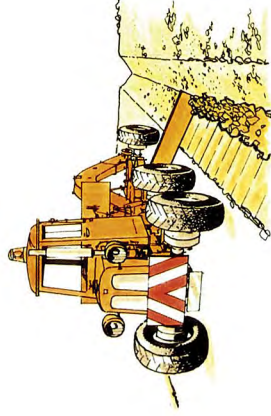

* See List of Terms, Volume I.





PART A - GRADING

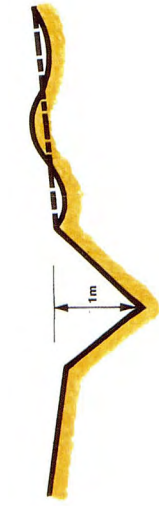

- The completed ditch should be **at least 1 metre** deep.
 - **Turnouts** should be constructed and maintained with a grader.
- These should lead the water away from the edge of the road and follow closely the natural contours of the ground.



- Turnouts should be spaced more closely as gradients become steeper.
- The discharge of water should be 'little and often' to minimise erosion risk on adjoining land.

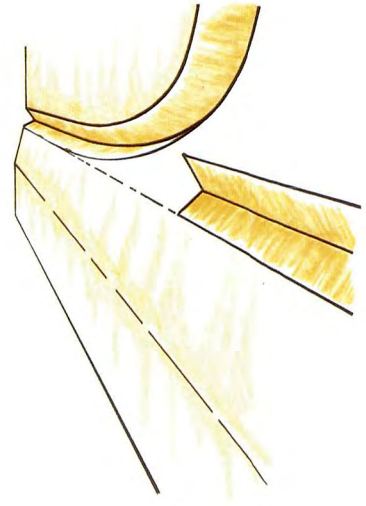



PART A - GRADING

4.5 COMPLETION AND REMOVAL OF TEMPORARY SIGNS

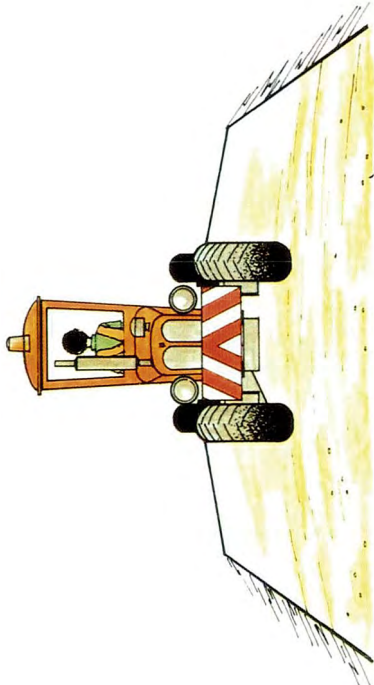

- Remove the traffic signs and load them back on the grader.
- Move on to next job.
- Clean the traffic signs on return to the depot.





PART A - GRADING

TYPICAL WORK REPORT

4.6 WORK REPORT

GRADING

Work Report No: _____ Date: _____
 District: _____ Gang: _____
 Zone: _____ Road No: _____
 Section: _____ from km _____ to km _____

QUANTITY OF WORK ACHIEVED:

Light grading _____ kms
 Heavy grading _____ kms
 Watering _____ kms
 Compaction _____ kms

WEATHER CONDITIONS:

Sunny Cloudy Rain

EQUIPMENT USED: DIESEL USED:

_____ Hrs _____ litres
 _____ Hrs _____ litres
 _____ Hrs _____ litres

MANPOWER USED: _____

COMMENTS:

Foreman: _____

- The report must be filled in **each day**, detailing:
 - the work carried out,
 - the resources used.





PART A - GRADING





Part B

LABOUR BASED RESHAPING





PART B - LABOUR BASED RESHAPING





PART B - LABOUR BASED RESHAPING

LABOUR BASED RESHAPING

Grading, as described in Part A, is the most commonly used technique for reshaping of earth and gravel roads.

However in certain circumstances, the high cost or non-availability of the specialist grading equipment make **Labour Based Reshaping** a more appropriate option.

Limited reshaping can be carried out as a **ROUTINE MAINTENANCE** activity. Large scale reshaping will normally be carried out as a **PERIODIC MAINTENANCE** activity.

In some road maintenance systems an individual attendant or lengthman lives close to a road and is responsible for the **ROUTINE MAINTENANCE** activities on that road. On low traffic volume roads (less than 50 vpd) it is often appropriate for **Reshaping** to be carried out by these **Labour Based** methods. The procedures are described as **METHOD A: ROUTINE RESHAPING**.

Large scale **PERIODIC MAINTENANCE** reshaping will usually require the deployment of a labour force and is described as **METHOD B: MAJOR RESHAPING**.





PART B - LABOUR BASED RESHAPING

1. THE TASK

The task is to restore the shape of earth and gravel roads by **Labour Based** methods.

The object is to restore the **camber*** by returning material from the road sides and shoulders towards the centre of the road. This will enable water to drain off easily.

A road with a flat or dished surface will collect water, and traffic will quickly cause potholes and rough spots.

It may also be necessary to carry out work on the mitre drains and culverts (Volume I) to ensure that water can drain away from the reshaped camber.



* See List of Terms, Volume I.





PART B - LABOUR BASED RESHAPING

2. DEFECTS

Labour Based Reshaping is used to correct

- Loss of Shape
- Ruts
- Potholes
- Corrugations
- Erosion Gullies
- Silted or Blocked Side Ditches

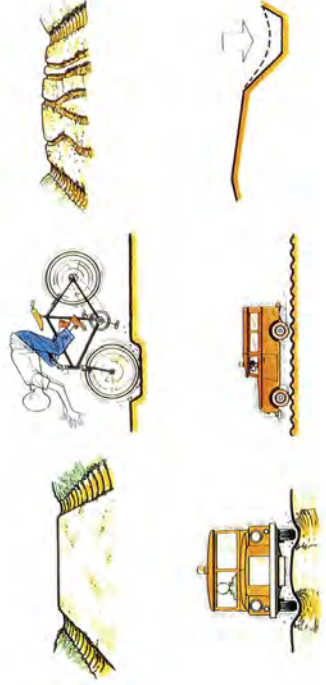



PART B - LABOUR BASED RESHAPING

METHOD A: ROUTINE RESHAPING



3. RESOURCES

3.1 PERSONNEL

- **Supervisor**
 - 1 foreman or overseer visiting regularly.

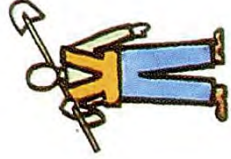

■ **Workforce**

- 1 or 2 attendants or lengthmen for each section of road.





PART B - LABOUR BASED RESHAPING

METHOD A: ROUTINE RESHAPING

3.2 PLANT AND TOOLS

- 1 pickaxe,
- 1 shovel,
- 1 hoe or mattock,
- 1 rake,
- 1 hand rammer with metal shoe,
- 1 wheelbarrow,
- 1 ditch and slope template and spirit level,
- 1 camber board and spirit level.

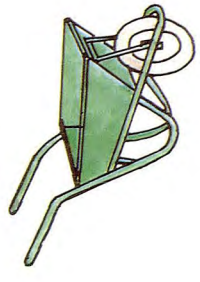
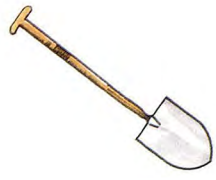



PART B - LABOUR BASED RESHAPING

METHOD A: ROUTINE RESHAPING

3.3 SIGNS AND SAFETY EQUIPMENT

On low volume roads the following should be provided.

- **Traffic Signs**
2 'Men Working' signs,

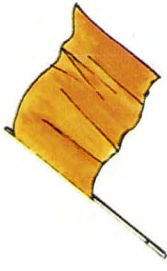

OR



2 yellow/orange flags to be placed on the road shoulder.

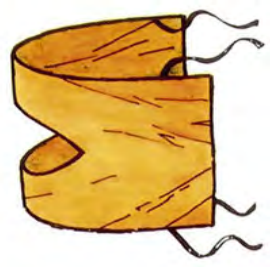

- **Clothing**

Yellow or orange coloured safety vest or safety harness to be worn by the attendant.





PART B - LABOUR BASED RESHAPING

**TYPICAL WORKSHEET
RESHAPING**

METHOD A: ROUTINE RESHAPING

4. MAINTENANCE METHOD

Worksheet No: _____ Date: _____

District: _____ Road No: _____

Section from km: _____ to km: _____

Roadway width _____ m

Ditch and Slope width _____ m

Ditch depth _____ cm

Cross fall _____ %

4.1 PRELIMINARY TASKS

- The handtools are assigned to the attendant who keeps them at his home for use as necessary.
- The worksheet will indicate the location and extent of the work to be carried out and the time required for the job.





PART B - LABOUR BASED RESHAPING

METHOD A: ROUTINE RESHAPING



4.2 EXECUTION OF THE WORK

- The attendant or lengthman transports the tools and safety items to the site using the wheelbarrow.
- The warning signs or flags are placed either side of the worksite.
- The attendant or lengthman trims the surfacing material with the pickaxe, hoe or mattock and rakes it to form the required camber and crossfall.
- The shape is checked with the camber board and spirit level.
- If gravel stockpiles are provided, any local depressions are filled with material transported in the wheelbarrow.
- The loose material is compacted with the hand rammer.





PART B - LABOUR BASED RESHAPING

METHOD B: MAJOR RESHAPING

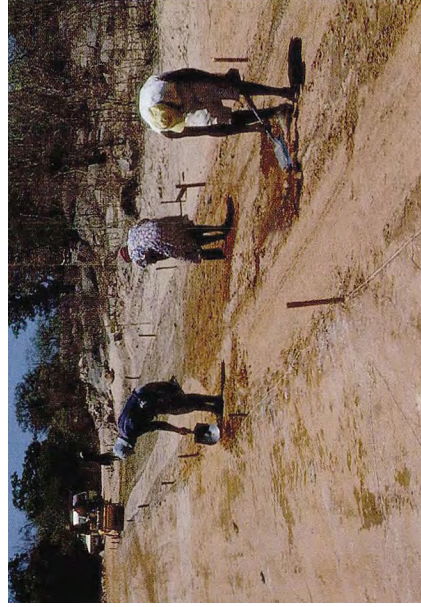

This method is appropriate when complete reshaping of the road cross section is required and the material in the side drains or at the side of the road is suitable for constructing the running surface. The method may also be used to reshape the road prior to (re)gravelling (Part E or F).

Major Reshaping may be carried out on low traffic volume roads which are still open to vehicles. However it is preferable to close the road and divert traffic, at least during working hours.

For **Major Reshaping** of high traffic volume roads, the road should be closed and diversions provided during working hours.





PART B - LABOUR BASED RESHAPING

METHOD B: MAJOR RESHAPING



5. RESOURCES

5.1 PERSONNEL

■ **Supervisor**

- 1 foreman or overseer,
- 1 headman for each 10 to 20 workmen (usually from the local workforce).

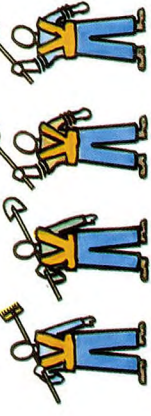

■ **Workforce**

- 20 to 40 workmen.

■ **Support (as necessary)**

- water carriers,
- storeman,
- watchmen,
- handtool sharpening and repairs.





PART B - LABOUR BASED RESHAPING



METHOD B: MAJOR RESHAPING

5.2 PLANT AND TOOLS

Approximate requirements - number will depend on conditions.

- 1 pickaxe for every 10 workmen,
- 1 hoe for every 2 workmen,
- 1 mattock for every 10 workmen,
- 1 shovel for every 2 workmen,
- 1 rake for every 5 workmen,
- 1 hand rammer for every 10 workmen,
- 1 wheelbarrow for every 10 workmen,
- 1 bush knife for every 10 workmen,
- 2 crowbars,
- 4 files (for sharpening tools),
- axe,
- saw,
- grass slasher,
- 10 ranging rods and adjustable profiles,
- 1 tape measure (30 metre),
- 1 camber board and spirit level,
- 1 ditch and slope template,
- 2 mason's hammers,
- wooden pegs,
- balls of string/sisal twine,
- if available, a hand or animal drawn roller.





PART B - LABOUR BASED RESHAPING

METHOD B: MAJOR RESHAPING



5.3 SUPPORT AND SAFETY ARRANGEMENTS

Arrangements should be made, for the following:

- **Recruitment** of workmen if employed casually,
- **Setting up temporary, site camp**
 - supervisor's accommodation and facilities,
 - handtool storage,
 - water supply.
- **Payment** of wages,
- **Signs and Safety Equipment**
 - when working on a low traffic volume road open to traffic, the signs and safety equipment detailed in Part D (Patching, Method A, Page II-90) should be used.
 - when closing the road and providing a diversion, the signs and safety equipment detailed in Part E (Mechanised Regravelling, Page II-122) should be used.





PART B - LABOUR BASED RESHAPING

**TYPICAL WORKSHEET
RESHAPING**

METHOD B: MAJOR RESHAPING

Worksheet No: _____ Date: _____

District: _____ Road No: _____

Section from km: _____ to km: _____

Roadway width _____ m

Ditch and Slope width _____ m

Ditch depth _____ cm

Cross fall _____ %

6. MAINTENANCE METHOD

6.1 PRELIMINARY TASKS (as necessary)

- Recruit or inform local work force.
- Set up temporary site camp for supervisor.
- Set up water supply arrangements.
- Plan payment arrangements.
- The worksheet will indicate the location and extent of the work to be carried out, along with the time required for the job.





PART B - LABOUR BASED RESHAPING

METHOD B: MAJOR RESHAPING

6.2 TEMPORARY SIGNPOSTING

When working on a low traffic volume road open to traffic, the signs and safety equipment should be deployed as shown in paragraph 4.2 of Part D (Page II-95).

When closing the road and providing a diversion, the signs and safety equipment should be deployed as shown in paragraph 4.2 of Part E (Page II-128).

On low-traffic roads, the Maintenance Engineer may approve the use of a simpler system of traffic control.

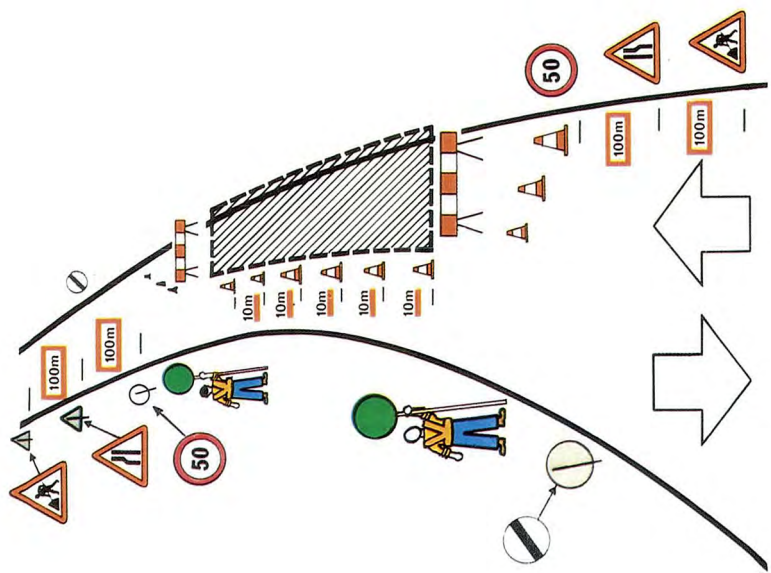

NOTE: SHOWN FOR DRIVING ON RIGHT





PART B - LABOUR BASED RESHAPING

METHOD B: MAJOR RESHAPING

6.3 EXECUTION OF THE WORK

The Method comprises the following steps:

- SETTING OUT
- EXCAVATION OF DITCH AND SLOPE
- EXCAVATION OF BACKSLOPE
- CAMBER FORMATION AND FINAL COMPACTION

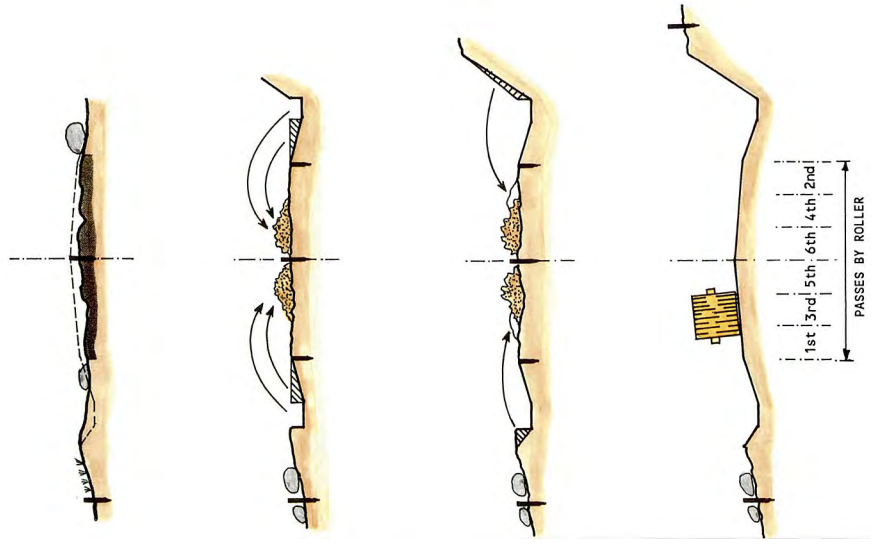



PART B - LABOUR BASED RESHAPING

METHOD B: MAJOR RESHAPING

SETTING OUT

- The PROFILE method of setting out enables a smooth vertical alignment to be re-established on a severely deteriorated road surface.
- The alignment will consist of straight gradients and vertical curves.
- The centre line of the road is pegged every 10 metres.
- A ranging rod is fixed at each 10 metre peg. Each ranging rod is fitted with a profile board. The profile board can slide up and down the ranging rod and be clamped at any height.

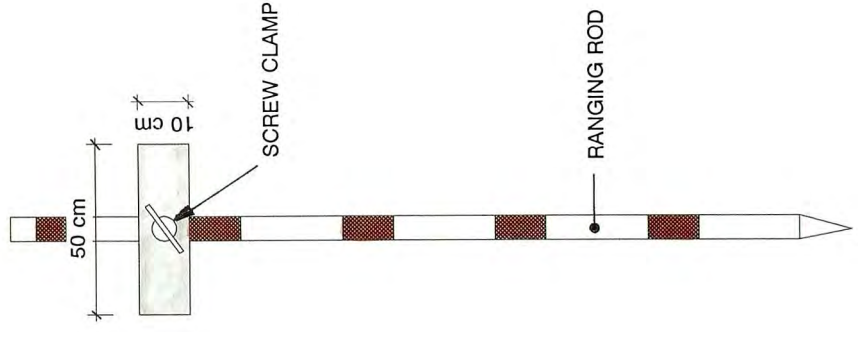



PART B - LABOUR BASED RESHAPING

METHOD B: MAJOR RESHAPING

- Setting out is arranged in sections of 60 to 100 metres, which approximate to either straight gradients or vertical curves.

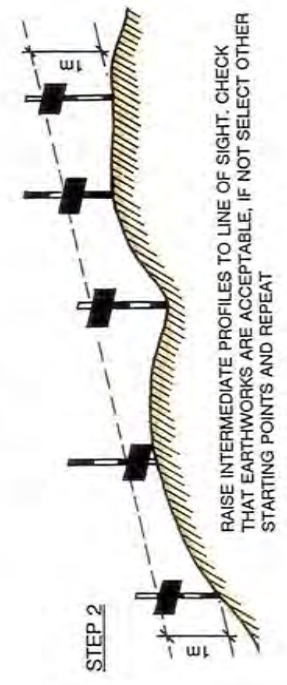
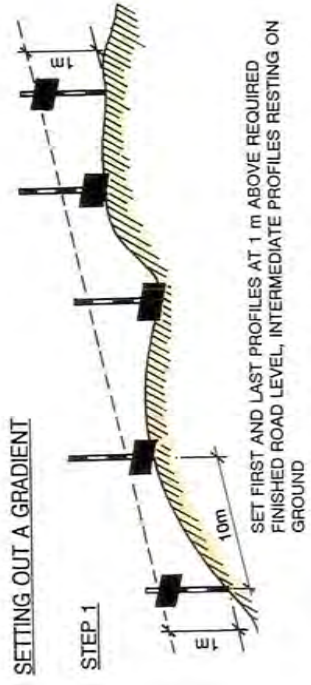

STEP 3

PLACE NEW CENTRE LINE PEGS AT EACH RANGING ROD WITH TOPS AT 1 m BELOW THE PROFILE BOARDS - THIS IS THE FINISHED ROAD CENTRE LINE LEVEL .





PART B - LABOUR BASED RESHAPING

METHOD B: MAJOR RESHAPING

Check that the amount of earthworks at each centre line (finished level) peg is acceptable, or repeat the procedure using different assumptions.

SETTING OUT A VERTICAL CURVE

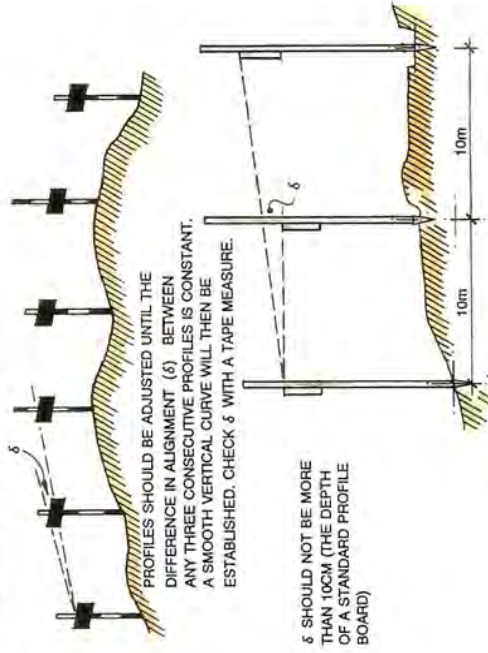

WHEN THE CURVE IS ACCEPTABLE, PLACE NEW CENTRE LINE PEGS AT EACH RANGING ROD WITH TOPS AT 1m BELOW THE PROFILE BOARDS - THIS IS THE FINISHED ROAD CENTRE LINE LEVEL.





PART B - LABOUR BASED RESHAPING

METHOD B: MAJOR RESHAPING

Once the centre line level pegs are fixed, set out the pegs for the edge of the roadway and both sides of the ditch using the tape measure, camber board and spirit level for the required road cross section.

Pegs should be driven in to the required finished cross section level, **or** a fixed height above.

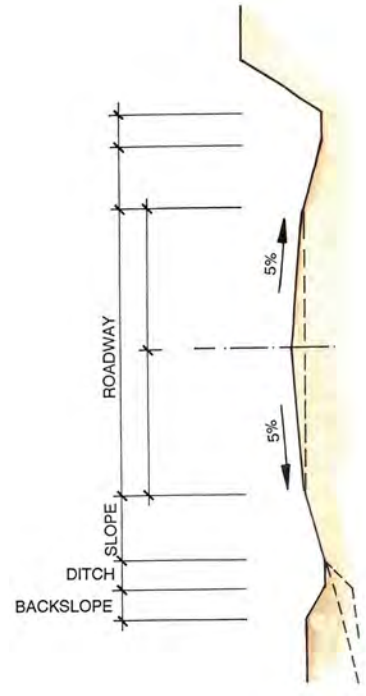



PART B - LABOUR BASED RESHAPING

METHOD B: MAJOR RESHAPING

EXCAVATE DITCH AND SLOPE

- Material is excavated from the ditch and slope area and used to form the camber until the required shape of ditch and slope is achieved.
- Check shape with the ditch and slope template, and spirit level.
- If too much material is excavated discard the surplus material well beyond the side drain.
- If the filling placed is greater than 15 cm deep, then it is preferable to spread and compact the fill material with rakes and hand rammers or a hand/animal drawn roller in 15-20 cm layers.

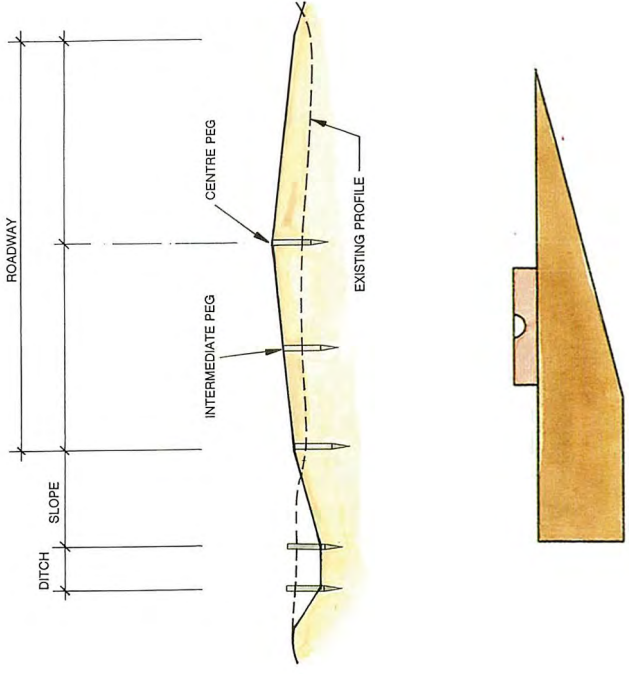



PART B - LABOUR BASED RESHAPING

METHOD B: MAJOR RESHAPING

EXCAVATE BACKSLOPE

If insufficient material is excavated to form the camber, dig additional material from the backslope or from beyond the side drain.

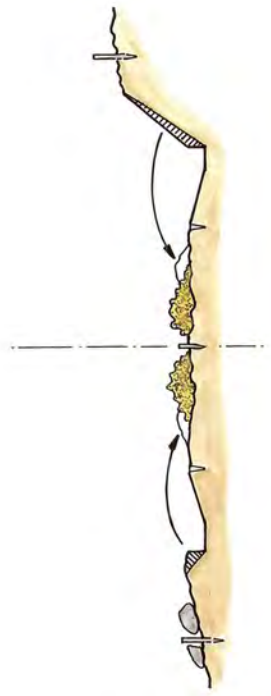



PART B - LABOUR BASED RESHAPING

METHOD B: MAJOR RESHAPING

CAMBER FORMATION AND FINAL COMPACTION

- Continue adding material to the camber to achieve the required profile **after** compaction.
- Stringlines stretched directly and diagonally across the running surface between the setting out pegs can be used to check the shape.
- Compact the fill material to the final profile, preferably using a hand or animal drawn roller.





PART B - LABOUR BASED RESHAPING

6.4 COMPLETION AND REMOVAL OF TEMPORARY SIGNS

On completion of the work the temporary signs and safety equipment are removed as described in Parts D (Pages II-102 and II-103) or E (Pages II-136 and II-137) as applicable.

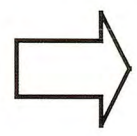



PART B - LABOUR BASED RESHAPING

TYPICAL WORK REPORT

RESHAPING

Work Report No: _____ Date: _____

District: _____ Gang: _____

Zone: _____ Road No: _____

Section: _____ from km _____ to km _____

QUANTITY OF WORK ACHIEVED:

Reshaping: _____ m

WEATHER CONDITIONS

Sunny Cloudy Rain

MANPOWER USED: _____

COMMENTS _____

Foreman: _____

6.5 WORK REPORT

The report must be filled in **each day**, detailing

- The work carried out,
- The resources used.





Part C DRAGGING



II-61



PART C - DRAGGING



II-62





PART C - DRAGGING

1. THE TASK

The task is to improve earth and gravel roads by **dragging** the existing surface material. Dragging is normally a ROUTINE MAINTENANCE task.

The **object** of regular and frequent dragging is to smooth out minor defects in the road surface and remove loose material from the surface. This results in a better running surface for traffic.

On some roads a thin layer of sand is used to cover the road base material and protect it from traffic wear. Frequent dragging is used to redistribute the sand disturbed by the traffic.

Dragging can be carried out using self propelled or towed **graders**. Towed graders weighing 1 tonne or more are suitable for this task. Alternatively, specially made **drags*** can be used, towed behind agricultural tractors.

On low-volume roads, frequent dragging may be used to reduce the need to grade the road. Grading is normally required after a number of dragging operations to mix the accumulated loose material back into the road surface.

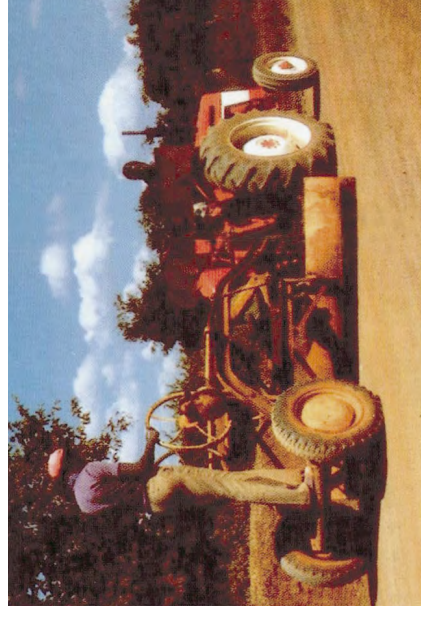

* See List of Terms, Volume I.





PART C - DRAGGING

2. DEFECTS

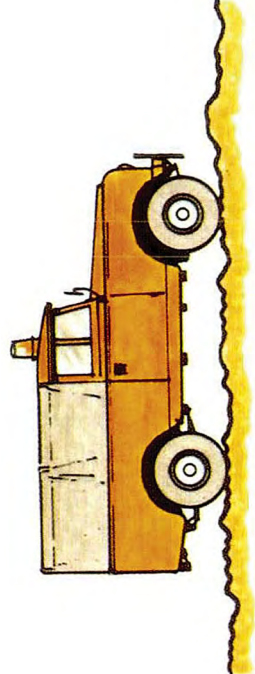

Dragging is used to correct

- Minor surface **deformation**.

Dragging will not remove corrugations once they have formed, nor will it restore camber* or lost material. **Grading** is needed to correct these problems.



* See *List of Terms, Volume I.*



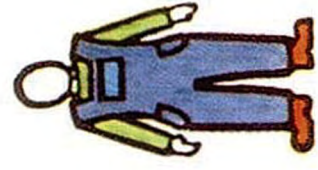
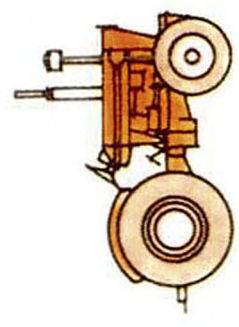

PART C - DRAGGING

3. RESOURCES

3.1 PERSONNEL

■ **Plant Operators and Drivers**

1 tractor driver and/or 1 grader operator for each machine.

■ **Work Force**

1 machine attendant for each tractor or motor grader.





PART C - DRAGGING

3.2 PLANT AND TOOLS

- 1 **Motor Grader** plus additional motor graders if available.

OR

For each towed grader or drag:

- 1 **Agricultural Tractor**
(It is sometimes possible to use draught animals to tow the drag).

WITH

- 1 **Towed Grader**

OR

- 1 **Drag**

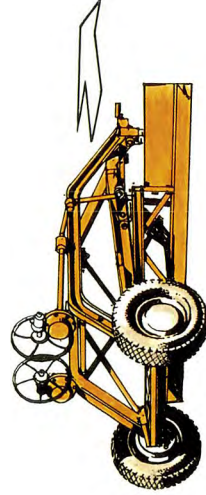
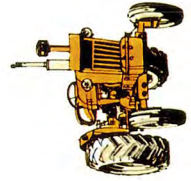
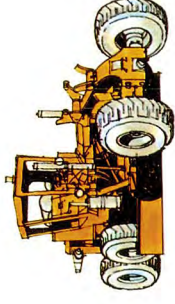



PART C - DRAGGING

TYPES OF DRAG
(Listed in order of increasing effectiveness)



- **Brushwood Drag**
Small branches tied together.

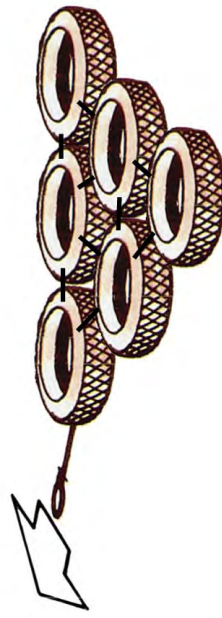

- **Tyre Sledge**
Old truck or tractor tyres chained together.

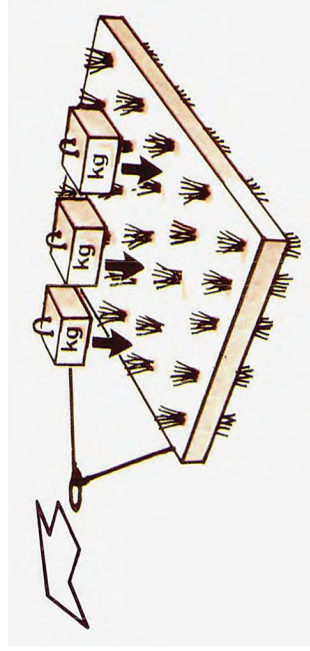

- **Cable Drag**
Bundles of steel cables bound together and fixed in a frame, weighted with concrete blocks to enable it to cut into the surface.
Care must be taken that pieces of the steel cable which may break off the drag are not left lying on the road.





PART C - DRAGGING

■ **Beam Drag**

rolled steel joist(s) or steel rail(s), weighted with concrete blocks, and towed at an angle to the road.

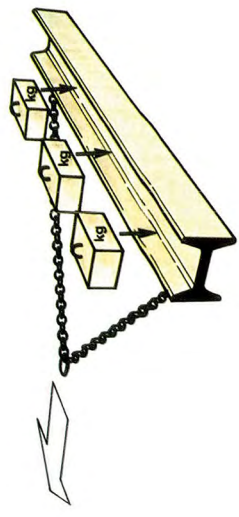

■ **Frame Drag**

steel 'A' frame using old grader blades.



■ **Tolard**

three to five blades at different angles under a box weighted with concrete blocks.

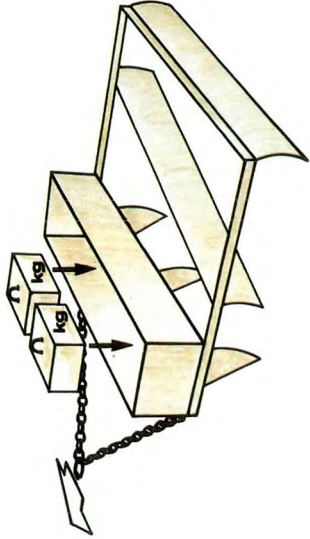



PART C - DRAGGING

3.3 SIGNS AND SAFETY EQUIPMENT

The following should be used where possible.

■ Clothing

Yellow or orange coloured safety vest or safety harness to be worn by the machine attendant.

■ Vehicles

The grader or tractor and drag should be painted yellow or orange and should carry red and white striped marker boards front and rear.

■ Lights

The grader or tractor should work with headlights switched on and, where possible, should carry yellow flashing warning lights.

■ Flags

If yellow flashing warning lights are not available, vehicles and equipment should carry yellow or orange flags.

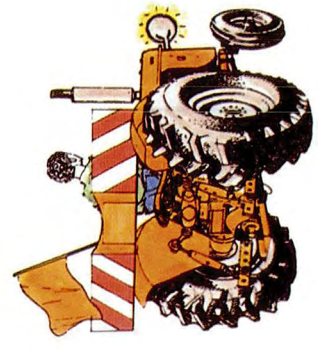
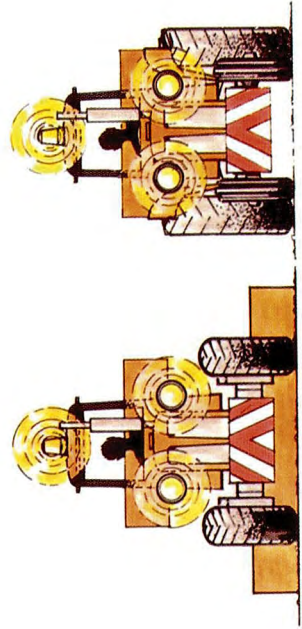
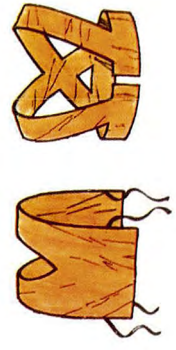



PART C - DRAGGING

TYPICAL WORKSHEET

4. MAINTENANCE METHOD

DRAGGING

4.1 PRELIMINARY TASKS

Worksheet No: _____ Date: _____

District: _____

Zone: _____ Gang: _____

Road No: _____ from km _____ to km _____

Section from km _____ to km _____ in _____ m width

EQUIPMENT TO BE USED:

Motorgraders: _____

Tractors: _____

Drags: _____

Towed Graders: _____

- **The worksheet** will indicate the location and extent of the work to be carried out and the time, equipment and personnel required for the job.





PART C - DRAGGING

Before setting out to start the job, a check should be made to ensure that everything needed is ready.

- **Plant and machinery** must be checked mechanically, greased and fuelled.
- **Drags** must be checked to ensure that they are complete and that any weights required are loaded.

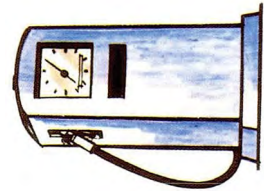
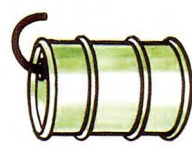



PART C - DRAGGING

4.2 WORKING WITH A TRACTOR AND DRAG



■ **The Machine Attendant**

directs traffic and helps the driver when turning the tractor and drag, removes unwanted material from path of tractor and clears the drag.

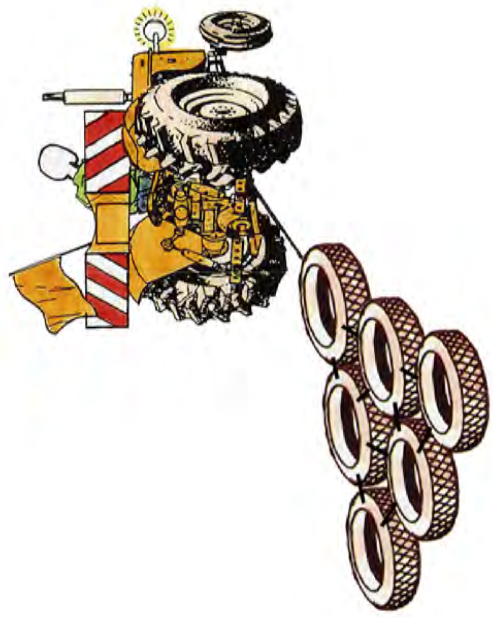

■ If the work is being done with a **tractor**, it should work in the same direction as the traffic.

The driver should not stop at junctions or on bends.





PART C - DRAGGING

- The tractor tows the drag at **up to 5 km/hr** depending on the type of drag and on the type and condition of the road surface.
- The length of pass will be given on the worksheet and should be as long as possible.
- The number of passes needed will depend upon the conditions and the width of the road.
- The equipment should work in the **same direction as the traffic flow**.

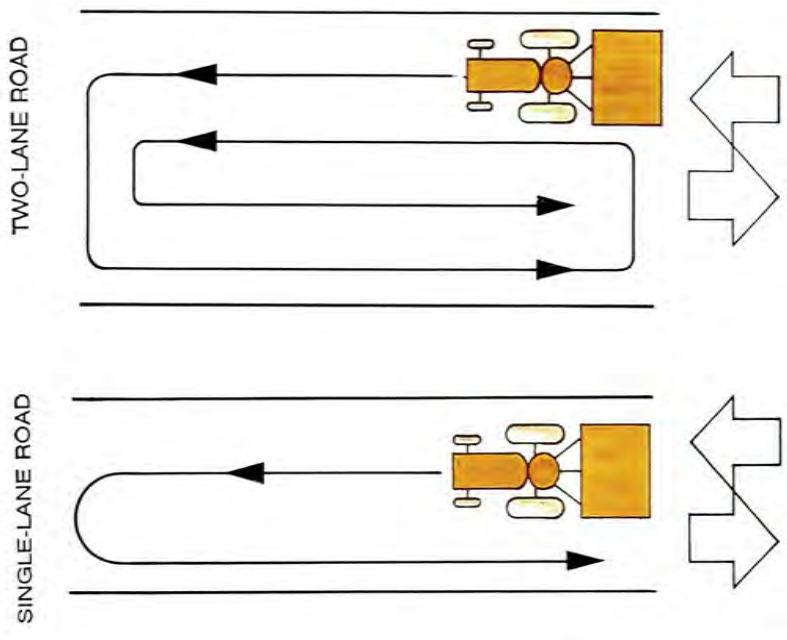

NOTE: SHOWN FOR DRIVING ON THE RIGHT



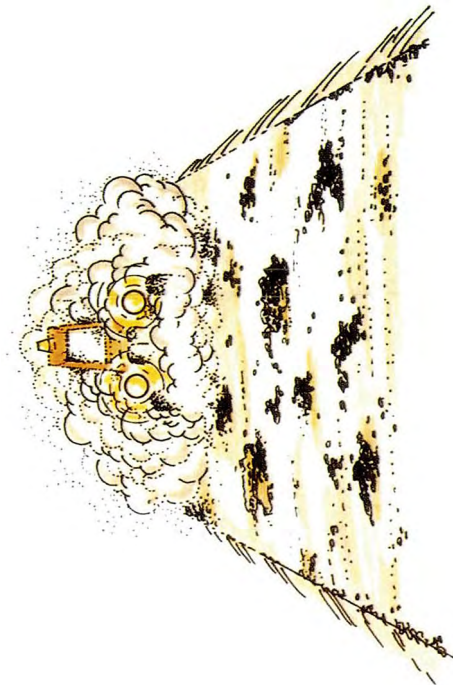

PART C - DRAGGING

- **DO NOT** drive too fast or the drag will jump over the surface irregularities and raise a lot of dust, it will also cause a hazard to traffic.
- Pieces of thorn scrub or steel cable which break off the drag must not be left on the road surface.





PART C - DRAGGING

4.3 DRAGGING WITH GRADERS

- When the work is to be done by **motor grader** or **towed grader**, it is most efficient if **several graders** can work together on the same section of road, one behind the other. In this case, graders work in the same direction along the road for several kilometres. On narrow roads two grader passes may be sufficient. Great care is required to warn approaching vehicles and allow them to pass the grading machines safely. If necessary a light vehicle should travel ahead of the graders with warning lights and signs.
- The **object** is to remove the loose material from the surface of the road and spread it evenly.



There are two basic methods of working.

The first spreads material from the centre line to both edges of the road (**Method A**).

The second spreads material from one side of the road to the opposite edge (**Method B**).

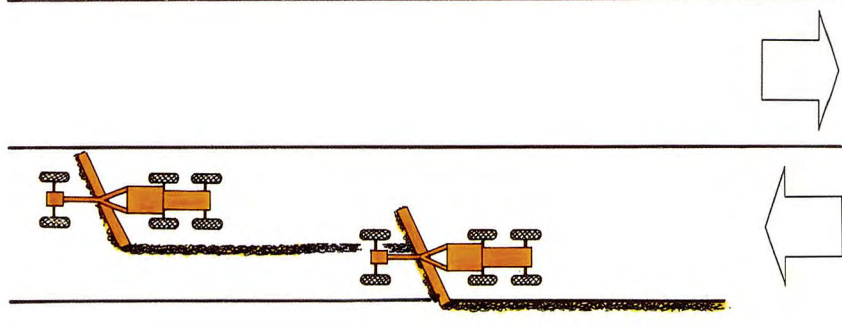



PART C - DRAGGING

METHOD A

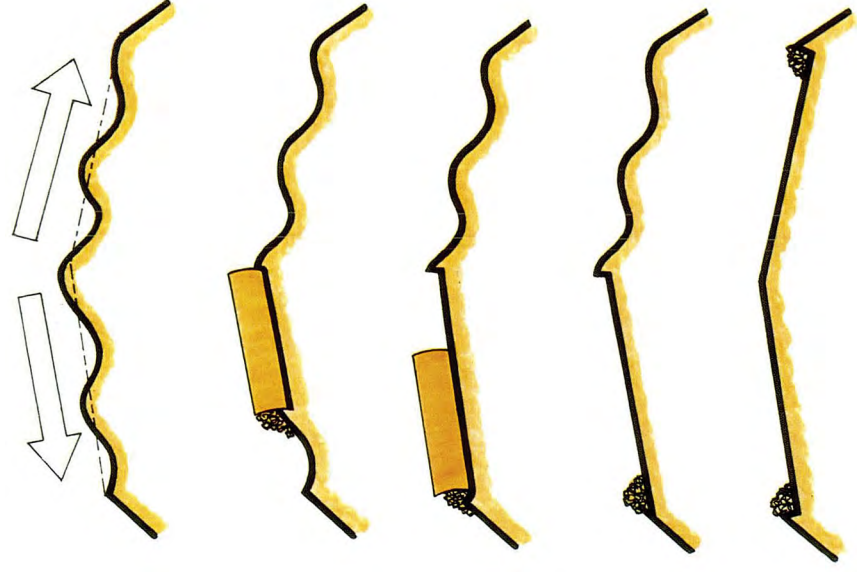

- The grader starts from the centre of the road and works towards the edge.
Shoulders are treated as part of the running surface.
- The **first** and **second passes** cut to the bottom of the surface irregularity and deposit a windrow at the edge of the road. Two passes may be required each side for wide roads.
- The other side of the carriageway is now graded in a similar way to complete the work and leave a smooth even surface between windrows.



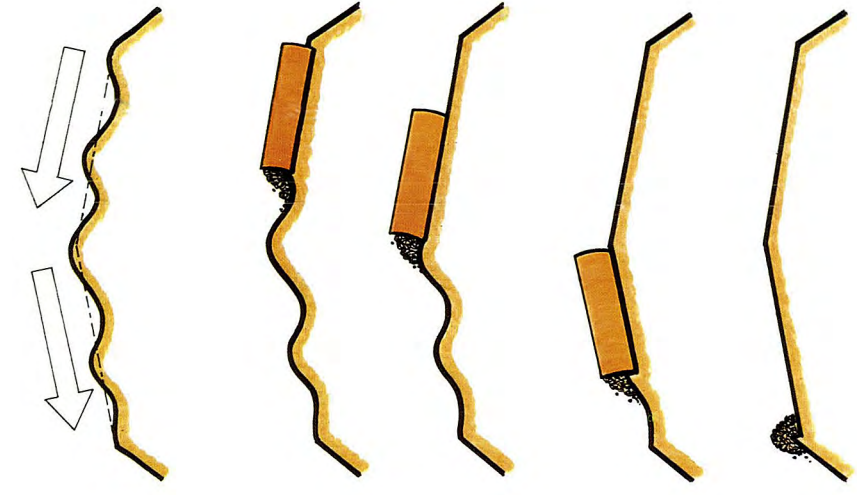

PART C - DRAGGING

METHOD B

- The grader starts from one edge of the road and works towards the other edge.
Shoulders are treated as part of the running surface.
- The **first** and **second passes** cut to the bottom of the surface irregularity and deposit a windrow at the centre of the road. Two passes may be required each side for wide roads.
- The **third** and **fourth passes** cut to the bottom of the surface irregularity and move the windrow to the edge of the road.





PART C - DRAGGING

- For both methods of dragging with a grader:
 - Slots should be cut through the windrows by the machine attendant at approximately **10 metre** intervals along the edges of the road.
- These will enable water to drain from the road surface in the event of unexpected rain.
- As loose material will have been removed from the surface of the road and a hard surface should remain, rolling should not be necessary with this type of dragging.

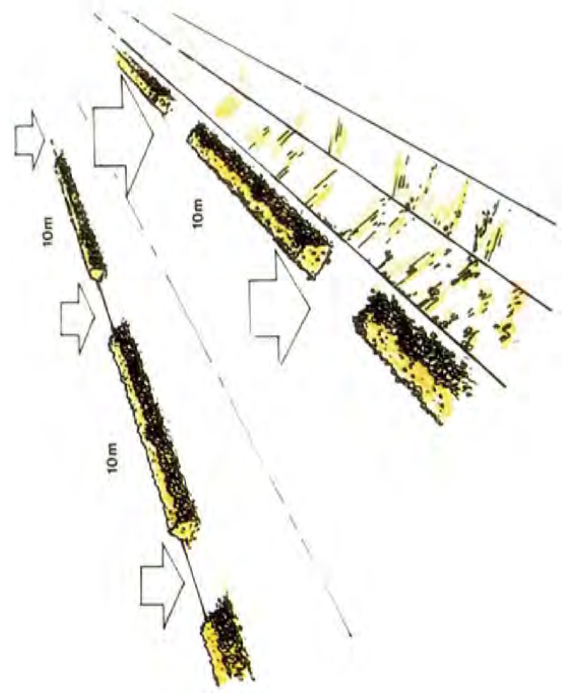



PART C - DRAGGING

- Windrows **must not** be left at the edge of the road during the wet season.
They tend to dam up the water leading to erosion of shoulders and side slopes.
The windrows should be mixed back into the running surface with a full grading operation before the wet season is established (Part A).

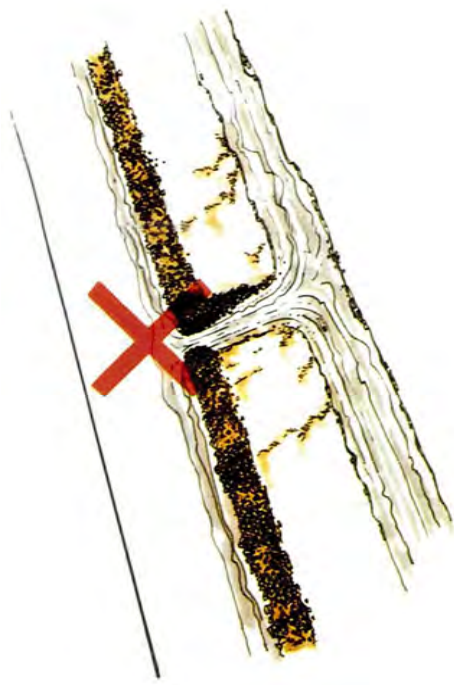

- **DO NOT** make a final pass* down the centre of the road with the grader blade horizontal.
This flattens the centre of the road and causes water to pond.
This leads to rapid deterioration of the surface.



* See List of Terms, Volume I.





PART C - DRAGGING

TYPICAL WORK REPORT

DRAGGING

Work Report No: _____ Date: _____
 District: _____ Gang: _____
 Zone: _____ Road No: _____
 Section: _____ from km _____ to km _____

QUANTITY OF WORK ACHIEVED:

Dragging: _____ kms

WEATHER CONDITIONS:

Sunny Cloudy Rain

EQUIPMENT USED:

_____ Hrs _____ litres
 _____ Hrs _____ litres
 _____ Hrs _____ litres

DIESEL USED:

MANPOWER USED: _____

COMMENTS: _____

Foreman: _____

4.4 WORK REPORT

The report must be filled in **each day**, detailing:

- the work carried out,
- the resources used.





Part D PATCHING



II-81



PART D - PATCHING





PART D - PATCHING

1. THE TASK



Patching is sometimes required between grading or reshaping operations, or before grading when the potholes or depressions are large.

Patching may either be used to repair worn or eroded areas or can be used to restore areas which become soft when wet.

This maintenance activity consists of replacing or adding new gravel surfacing material over relatively small areas.

Patching may be carried out by a mobile gang or by labour-based methods.

Patching is normally used to refer to resurfacing work involving less than 1 or 2 truck or trailer loads of material per day. Large scale work is usually called **Spot Regravelling** or **Gravelling** (Parts E or F).





PART D - PATCHING

2. DEFECTS

Patching is used to correct

- Potholes
- Ruts
- Soft Spots
- Erosion Gullies

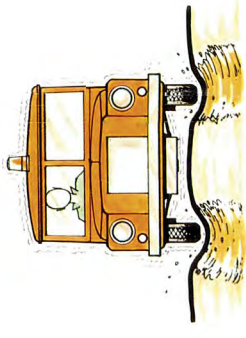
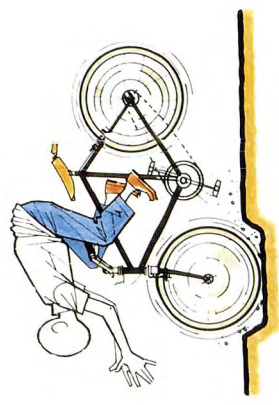



PART D - PATCHING

Patching is not a satisfactory method of repairing **corrugations**. **Grading** (Part A) or labour based reshaping (Part B) should be used to repair these defects.

Where there are large numbers of **potholes**, the section will need **scarifying*** with a self propelled grader and possibly **regravelling** (Part E or F).

Patching may be used instead of grading on self-cementing gravels or gravels with large lumps.

* See List of Terms, Volume I.



PART D - PATCHING

METHOD A: MOBILE GANG

3. RESOURCES

3.1 PERSONNEL

■ **Supervisors**

1 foreman.



■ **Plant Operators and Drivers**

1 driver.



■ **Workforce**

- 2 to 6 labourers,
- 2 traffic controllers.

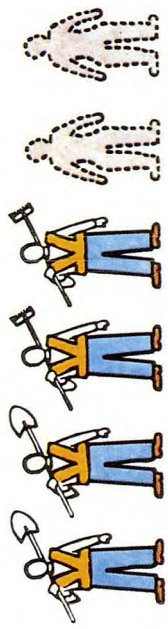



PART D - PATCHING

METHOD A: MOBILE GANG

3.2 PLANT AND TOOLS

■ **Vehicles**

1 small truck.

OR

1 tractor and trailer(s).

If two trailers are available, one trailer can be loaded while the other is hauled to the worksite.

■ **Compactors**

1 hand controlled vibrating roller, and fuel (plus ramps* to help load onto truck or trailer).

OR

1 hand rammer with metal shoe for each labourer used on compaction work.

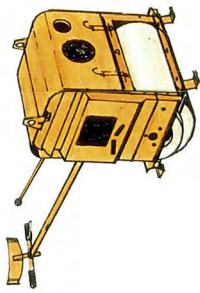
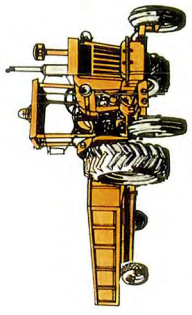
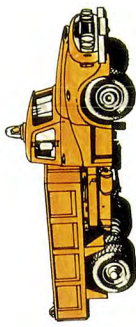

* See List of Terms, Volume I.





PART D - PATCHING

■ Tools

- 1 broom for every two labourers,
- 1 pickaxe for every two labourers,
- 1 shovel for every two labourers,
- 1 hoe or mattock for every two labourers,
- 1 rake for every two labourers,
- 1 wheelbarrow,
- 1 hand rammer with metal shoe for each labourer used on compaction work (if no vibrating roller is available),
- 1 drum for water (200 litre),
- 1 bucket or watering can.

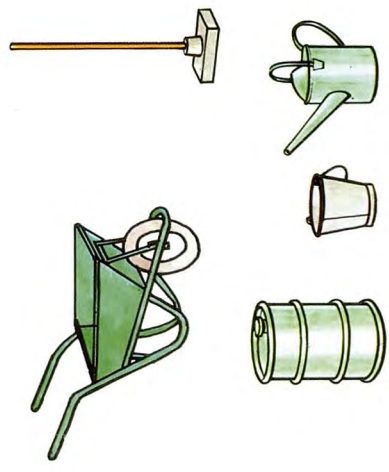
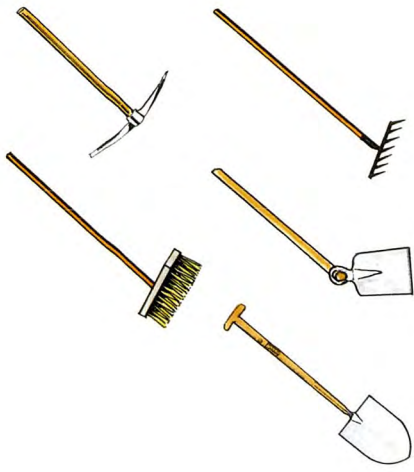



PART D - PATCHING

METHOD A: MOBILE GANG

3.3 MATERIALS

- **Gravel** for patching should be stockpiled at the quarry or maintenance camp, or dumped at the side of the road near where it will be used (so that it does not block the road or drainage system).

The gravel must be at least as good a **quality** as the material already surfacing the road. Its use must be approved by the **Maintenance Engineer** and must meet Departmental specifications.



- **Water** must be carried from the depot if it is not obtainable near the site.

In either case, a container will be needed.

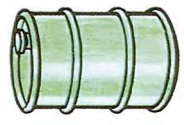



PART D - PATCHING

METHOD A: MOBILE GANG

3.4 SIGNS AND SAFETY EQUIPMENT

The following items should be provided where possible.

■ Traffic Signs

- 2 Reversible 'Stop/Go' signs,
- 2 'Speed Limit' signs (50 km/hr),
- 2 'Men Working' signs,
- 1 'Road Narrows From Right' sign,
- 1 'Road Narrows From Left' sign,
- 2 'End of Restriction' signs.

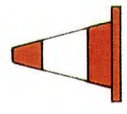
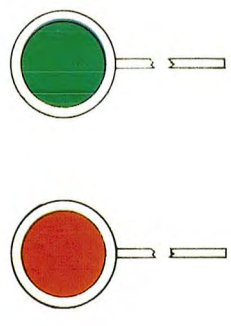

■ Barriers

2 lane closure barriers.

■ Traffic Cones

As many as are required; at least 10 will usually be needed.





PART D - PATCHING

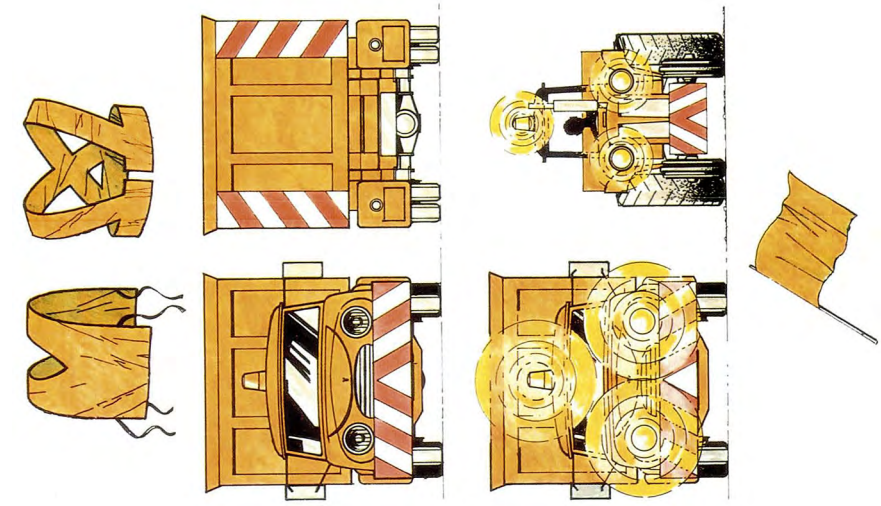

■ Clothing

Yellow or orange coloured safety vests or safety harnesses to be worn by the supervisor and all the work force.

■ Vehicles

All vehicles and equipment should be painted yellow or orange and should carry red and white striped marker boards front and rear.

■ Lights

All vehicles and equipment should work with headlights switched on and, where possible, should carry yellow flashing warning lights.

■ Flags

If yellow flashing warning lights are not available, each vehicle and item of equipment should carry yellow or orange flags.



PART D - PATCHING

TYPICAL WORKSHEET

METHOD A: MOBILE GANG

PATCHING

4. MAINTENANCE METHOD

4.1 PRELIMINARY TASKS

Worksheet No: _____ Date: _____

District: _____ Gang: _____

Zone: _____ Road No: _____

Section: _____ from km _____ to km _____

Materials: _____ trucks of _____ m³ = _____ m³

_____ trailers of _____ m³ = _____ m³

- **The worksheet** will indicate the location and extent of the work to be carried out and the time, equipment and personnel required for the job.





PART D - PATCHING

Before setting out to start the job, a check should be made to ensure that everything needed is ready.

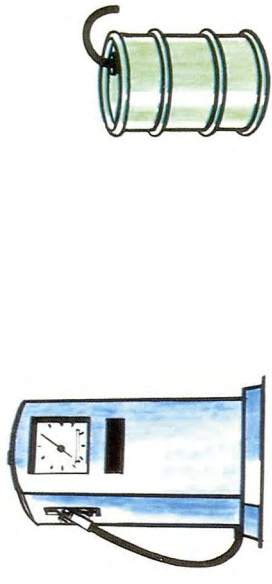

- **The Truck or tractor and trailer** must be fuelled, checked mechanically and have water and oil levels checked.

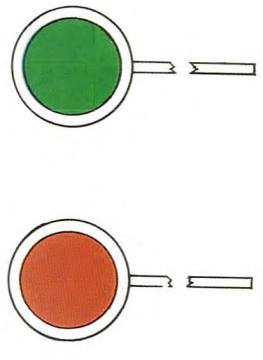

- **Traffic signs, barriers and cones** must be obtained and loaded onto the truck or trailer.

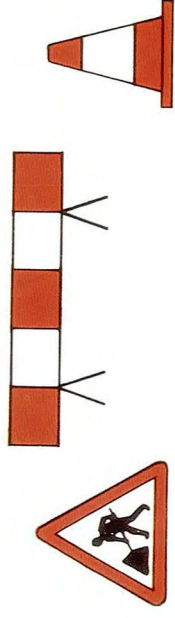



PART D - PATCHING

Tools and equipment must be obtained and loaded onto the truck or trailer. The roller may be loaded with the help of ramps* or a hoist.

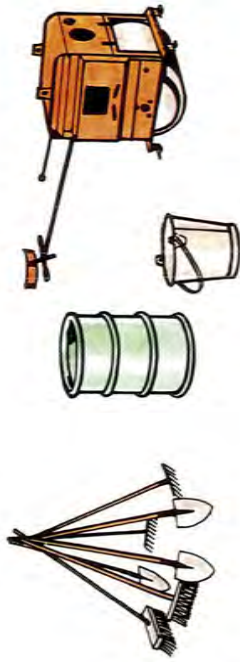

- The drum must be filled with **water** if none is available on site.
- Arrangements must be made to load **gravel** onto the truck or trailer either at the depot or at a quarry.

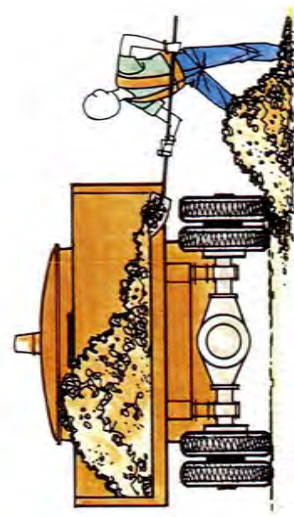

* See *List of Terms, Volume I.*





PART D - PATCHING

METHOD A: MOBILE GANG

4.2 TEMPORARY SIGNPOSTING

Before work starts, warning signs, barriers and cones must be placed around the work area.

Work should be carried out on one side of the road at a time, allowing traffic to pass on the other.

Signs must be placed in the following order:

- **'Men Working'** signs should be placed **200 metres** in front of the work area.
- **'Road Narrows'** signs should be placed **100 metres** in front of the work area.
- **'Speed Limit'** signs should be placed at the start of the work area.
- **Barriers** should be placed at each end of the work area.
- **Cones** should be placed in a taper at the approaches to the work area and at a maximum spacing of **10 metres** along the middle of the road next to the work area.
- **'End of Restriction'** signs should be placed **50 metres** beyond the work area.

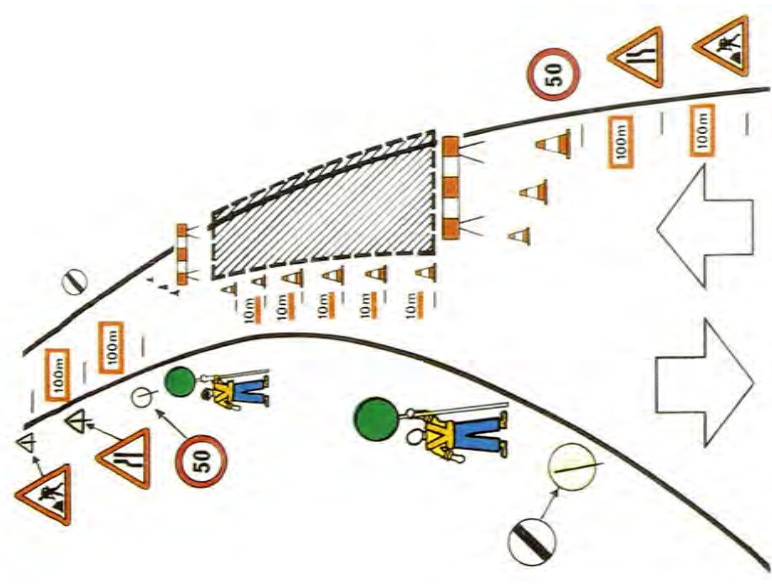

NOTE: SHOWN FOR DRIVING ON THE RIGHT





PART D - PATCHING

- **Traffic controllers** should stand next to the barriers in the centre of the road to operate the reversible 'Stop/Go' signs.

The controller closest to the oncoming traffic should decide when to stop the flow and allow traffic to travel in the other direction. Traffic should be stopped in both directions when works vehicles enter, leave or turn at the worksite.

On low-traffic roads, the Maintenance Engineer may approve the use of a simpler system of traffic control.





PART D - PATCHING

METHOD A: MOBILE GANG

4.3 EXECUTION OF THE WORK

- The material is off-loaded manually.



OR

Tipped onto the shoulder adjacent to where the patching is required. Material must never be dumped onto the road.



- **Loose material and standing water** is brushed from the pothole or rut to be patched.





PART D - PATCHING

- Large or deep potholes should have their sides cut back to be vertical and to reach sound material.
- The **moisture content** of the material can be checked quickly by squeezing it in the hand.
If the material is wet enough to stick together, it is suitable for use.
If water runs out of the material, it is too wet and should not be used.
- If the material is dry, the area to be patched should be sprinkled with water and water should also be added to the patching material.

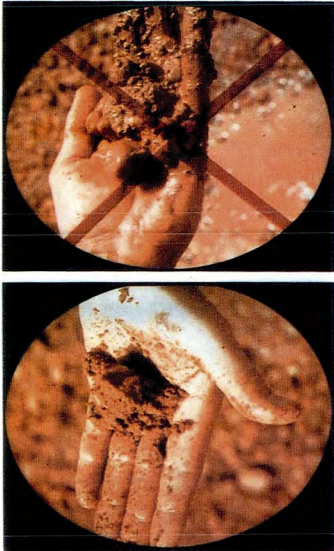



PART D - PATCHING

- The area is filled with gravel to a depth of about **10 centimetres**.
- If the material is dry, it should be sprinkled with water to help compaction.
- The layer is then compacted using the **roller or hand rammer**.
- In this way the thickness of the patch is built up in layers.

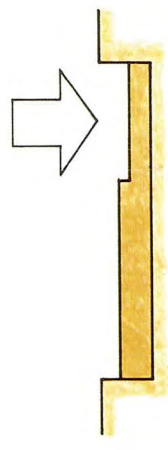



PART D - PATCHING

- Finally, the patched area is filled evenly with the gravel to approximately **3 centimetres** above the level of the surface and is spread and raked to the correct shape. 3 centimetres is approximately the thickness of a rake handle.

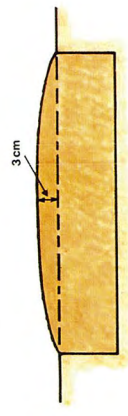

- The patch is then compacted using the **roller** or **hand rammer** to give a surface which is slightly above the level of the surrounding road.

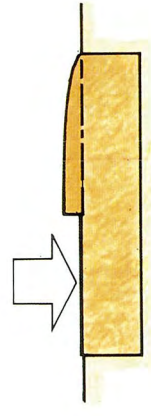

- Both large or small areas to be patched are repaired in the same way, the rammer is used for the smaller potholes. The roller is used for larger areas although the hand rammers will still be required for the corners and short edges.





PART D - PATCHING

- Patching work started **must not** be left unfinished overnight.
At night the site should be made safe for traffic and all signs and obstacles removed from the road.

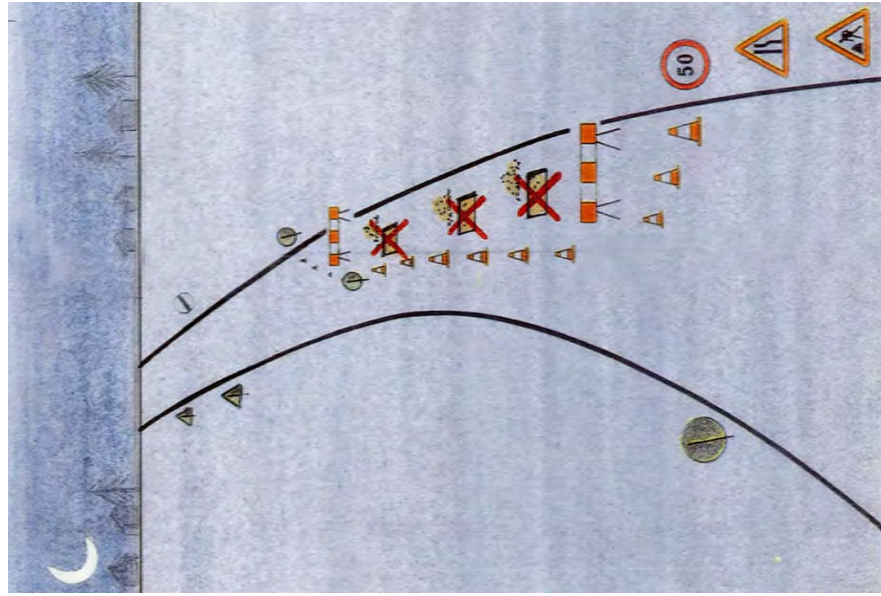



PART D - PATCHING

METHOD A: MOBILE GANG

4.4 COMPLETION AND REMOVAL OF TEMPORARY SIGNS

- Load tools, equipment and unused materials back onto the truck or trailer.
- Remove the signs, cones and barriers and load them onto the truck or trailer in the following order:
 - 1 'End of Restriction' signs,
 - 2 Traffic cones,
 - 3 'Speed Limit' signs,
 - 4 Barriers,
 - 5 'Road Narrows' signs,
 - 6 'Men Working' signs.

Equipment and traffic signs **must not** be left at the road side for use the next day.

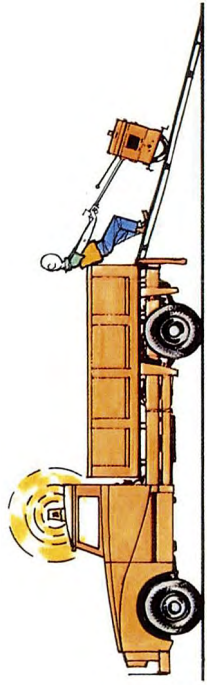



PART D - PATCHING

- Ensure that the site is left clean and tidy with no stockpiles of material left on the road.
- Move onto the next job.
- Inspect traffic signs and clean if necessary.

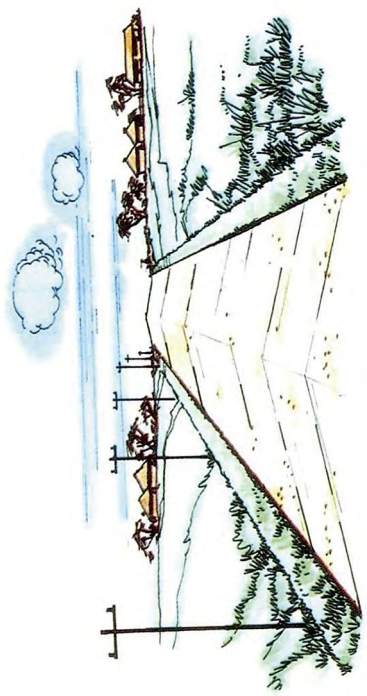



PART D - PATCHING

TYPICAL WORK REPORT

4.5 WORK REPORT

PATCHING

The report must be filled in **each day**, detailing:

Work Report No: _____ Date: _____

District: _____ Gang: _____

Zone: _____ Road No: _____

Section: _____ from km _____ to km _____

WEATHER CONDITIONS:

Sunny Cloudy Rain

MATERIALS USED:

Gravel: _____ m³

EQUIPMENT USED:

_____ Hrs _____ litres

_____ Hrs _____ litres

_____ Hrs _____ litres

MANPOWER USED:

COMMENTS:

Foreman:





PART D - PATCHING

PATCHING

METHOD B: LABOUR BASED

In some road maintenance systems an individual attendant or lengthman lives close to a road and is responsible for the ROUTINE MAINTENANCE activities on that road. On low traffic volume roads (less than about 50 vpd*) it is often appropriate for **patching** to be carried out by these labour based methods.



* vpd: vehicles per day





PART D - PATCHING

METHOD B: LABOUR BASED

5. RESOURCES

5.1 PERSONNEL

- **Supervisor**
1 foreman or overseer visiting regularly.



- **Workforce**
– attendant or lengthman.

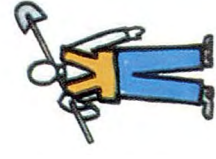



PART D - PATCHING

METHOD B: LABOUR BASED

5.2 PLANT AND TOOLS

- 1 broom,
- 1 pickaxe,
- 1 shovel,
- 1 hoe or mattock,
- 1 rake,
- 1 hand rammer with metal shoe,
- 1 wheelbarrow,
- 1 bucket or watering can.

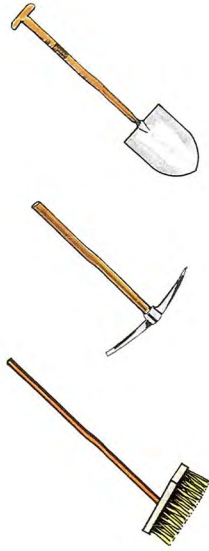



PART D - PATCHING

METHOD B: LABOUR BASED

5.3 MATERIALS

- Gravel for patching should be obtained from the quarry by truck or tractor and trailer. This is most efficiently done when major regravelling works are being carried out in the area of the road.
- The gravel should be stockpiled at convenient locations for the attendant to use on his section of road. The stockpiles must not obstruct the road, the shoulder or the drainage system.
- Where there is no space in the road reserve the stockpile should be placed downhill of a turnout drain to avoid blocking the drainage system.
- If possible a one truck or trailer load stockpile should be left every 100 to 200 metres along the road.

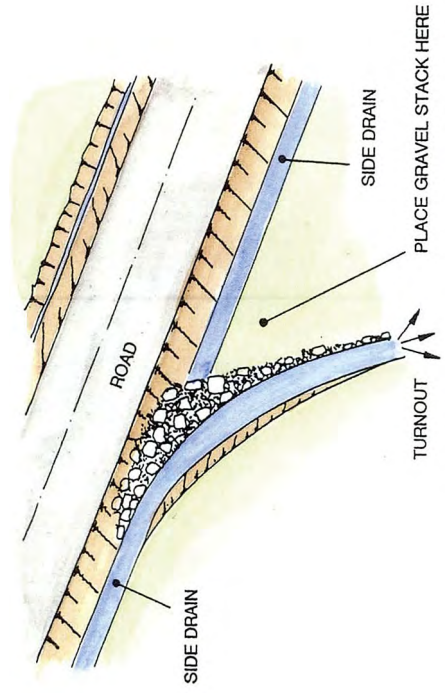



PART D - PATCHING

METHOD B: LABOUR BASED

5.4 SIGNS AND SAFETY EQUIPMENT

On low traffic volume roads the following should be provided.

- **Traffic Signs**
2 'Men Working' signs,



OR

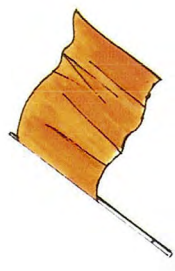

2 yellow/orange flags for placing on the shoulder.

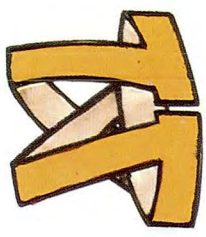

- **Clothing**
Yellow or orange coloured safety vest or safety harness to be worn by the attendant.





PART D - PATCHING

TYPICAL WORKSHEET

METHOD B: LABOUR BASED

PATCHING

6. MAINTENANCE METHOD

6.1 PRELIMINARY TASKS

Worksheet No: _____ Date: _____

District: _____

Section: _____ from km _____ to km _____

Materials: _____ trucks of _____ m³ = _____ m³

_____ trailers of _____ m³ = _____ m³

- The handtools are assigned to the attendant who keeps them at his home for use as necessary.

- The worksheet will indicate the location and extent of the work to be carried out and the time required for the job.





PART D - PATCHING

METHOD B: LABOUR BASED



6.2 EXECUTION OF THE WORK

- The attendant should use the wheelbarrow to carry the tools and safety items to the site.
- The warning signs or flags must be placed either side of the worksite.
- The attendant should use the wheelbarrow to transport the gravel material from the stockpiles to the **patching** site.
- The **patching** should be carried out as shown for the mobile gang.
- The warning signs or flags must be removed after the work.
- The work report must be filled in for each day's work.





PART D - PATCHING



II-112





Part E

REGRAVELLING (mechanised)



II-113



PART E - REGRAVELLING (mechanised)



II-114





PART E - REGRAVELLING (mechanised)

1. THE TASK



The surfacing material of unpaved roads is worn away by traffic, eroded by rain and blown away as dust.

Before all the gravel surfacing has worn away the road requires **regravelling**.

Regravelling is normally a **PERIODIC MAINTENANCE** task.

It is important that the **Maintenance Engineer** plans regravelling work well in advance so that work is carried out before serious defects appear.

Before regravelling is carried out, it is important to make any necessary repairs or improvements to the **camber*** and **drainage system** of the road. If this is not done, the new gravel surface will deteriorate very quickly.

Regravelling is normally carried out with one layer 15 cm thickness.

Usually a continuous layer of gravel is laid on the existing running surface, however on some occasions only short stretches showing severe defects are covered under a **spot regravelling** operation.

'Mechanised' regravelling using heavy plant is described in this Part (E). Part F describes regravelling carried out by labour and tractor methods.

* See *List of Terms, Volume I.*



PART E - REGRAVELLING (mechanised)

2. DEFECTS

Regravelling is used to correct

- **Loss of surfacing material**

Regravelling is needed before the subgrade* is exposed on the road surface. This will be seen particularly in ruts and depressions.

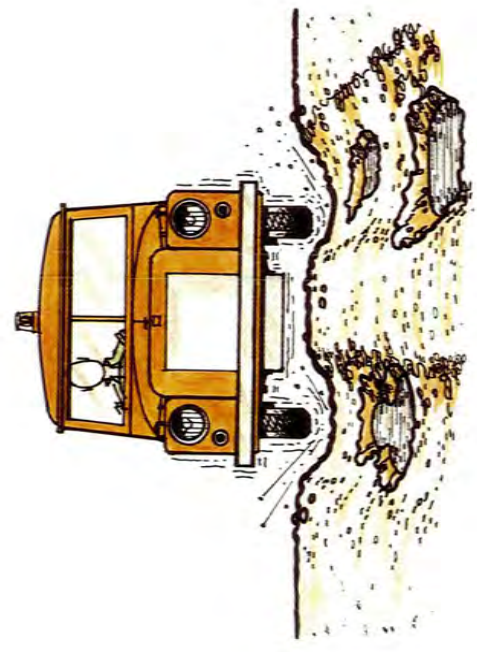
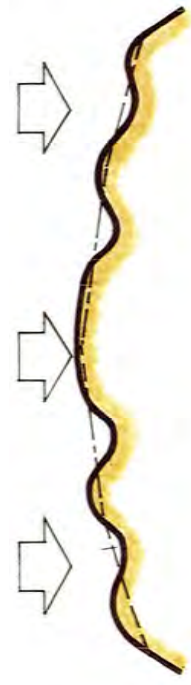

Regravelling is also used to correct

- **Loss of shape**
- **Ruts**
- **Potholes**
- **Erosion Gullies**

When these are **severe**.

In these cases grading (Part A) or reshaping (Part B) is carried out before the regravelling operation.

* See *List of Terms, Volume I.*





PART E - REGRAVELLING (mechanised)

3. RESOURCES

3.1 PERSONNEL

■ **Supervisors**

- 1 foreman at the road site,
- 1 foreman at the quarry or stockpile.

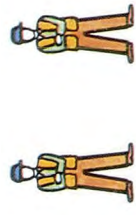

■ **Plant Operators and Drivers**

- 1 bulldozer operator,
- 1 loader operator,
- 1 driver for each tipper truck,
- 1 grader operator,
- 1 operator for each roller,
- 1 driver for each water tanker.

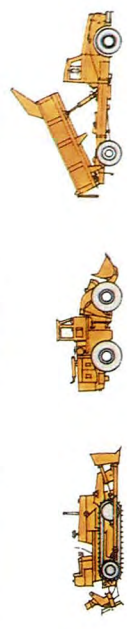

■ **Workforce**

- 1 machine attendant for each item of plant and equipment,
- mechanics for daily servicing and minor repairs.

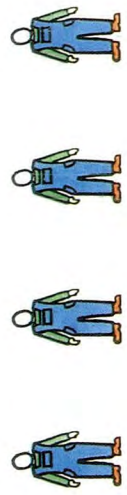



PART E - REGRAVELLING (mechanised)

3.2 PLANT AND TOOLS

The numbers of each type of plant will depend on the gravel haul distance and plant availability.

■ **Bulldozers**

- 1 bulldozer.

■ **Loaders**

- 1 wheeled or tracked loader.

■ **Trucks**

- tipper trucks, depending on haul distance and availability (typically 4 to 6).

■ **Graders**

- 1 grader, preferably of at least 135 hp (100 kW).

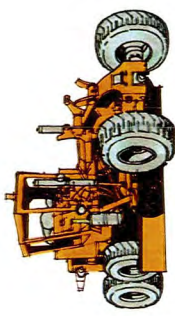
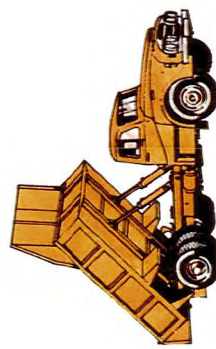
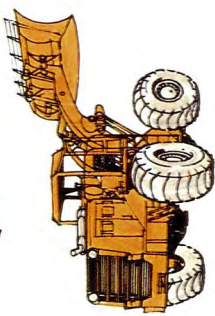
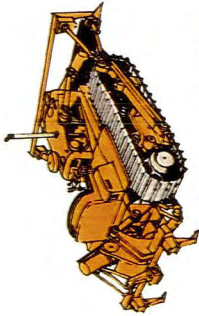



PART E - REGRAVELLING (mechanised)

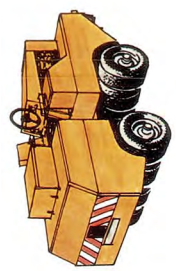

- **Rollers**
 - 1 or 2 rollers.



- **Water Tankers**
 - 1 water tanker, if the gravel being laid is dry.
More tankers will be needed if water has to be brought a long distance.

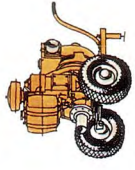

- **Pumps**
 - 1 pump of sufficient capacity to load the tankers quickly.



- **Other Vehicles**
 - 2 light vehicles for transport of the two supervisors.





PART E - REGRAVELLING (mechanised)

■ **Support**

A low loader will be required to transport some of the equipment items between successive quarry and work sites. Transport for fuel will also be required. Arrangements must also be made for lubrication, servicing and minor repairs, and site refuelling.

■ **Options**

For small regravelling jobs or short hauls (up to about 10 km), it may be appropriate to work with simpler plant than described in this Part of the handbook. Gravel can be quarried and loaded by hand and hauled to the site using tractors and trailers. See Part F for this option.

5% CAMBER BOARD

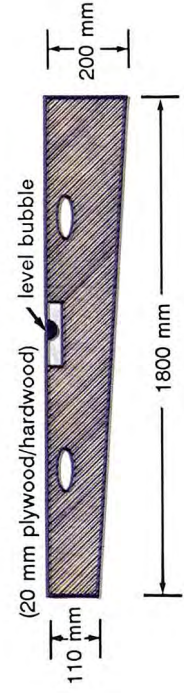

■ **Tools**

A camber board made as shown from 20 mm treated plywood or hardwood to give a 1 in 20 (5%) slope. A selection of handtools will be required for the machine attendants (see Part D, Page II-88).





PART E - REGRAVELLING (mechanised)

3.3 MATERIALS

- Gravel obtained from a quarry or gravel pit must be of a quality that meets the Departmental specifications and also be approved by the **Maintenance Engineer**.
- A source of **water** will be needed as near as possible to the site.





PART E - REGRAVELLING (mechanised)

3.4 SIGNS AND SAFETY EQUIPMENT

Whenever possible during regravelling, a diversion should be opened for traffic and the following safety items should be provided.



- **Traffic Signs**
 - 2 'Men Working' signs,
 - 1 'Turn Left' arrow,
 - 1 'Turn Right' arrow,
 - 4 'Keep Left/Right' arrows,
 - 2 'End of Restriction' signs.

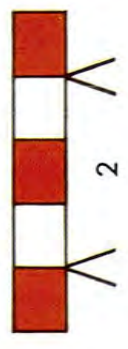

- **Barriers**
 - 2 lane closure barriers.

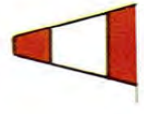

- **Traffic Cones**
 - As many as are required, but at least 10 will usually be needed.





PART E - REGRAVELLING (mechanised)

Although the road will be completely closed, it is still necessary for workmen to wear safety vests and for vehicles to carry warning lights for the safety of site operations.

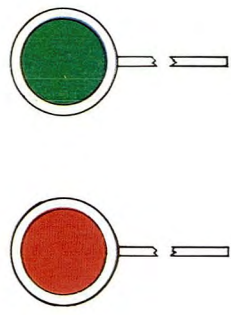

No Diversion

If it is not practical to provide a diversion, then working must be restricted to one side of the road at a time and safety equipment as listed under **Gravel Patching in Part D** (Pages II-90 and II-95) will be required. This includes both safety vests and warning lights on vehicles.

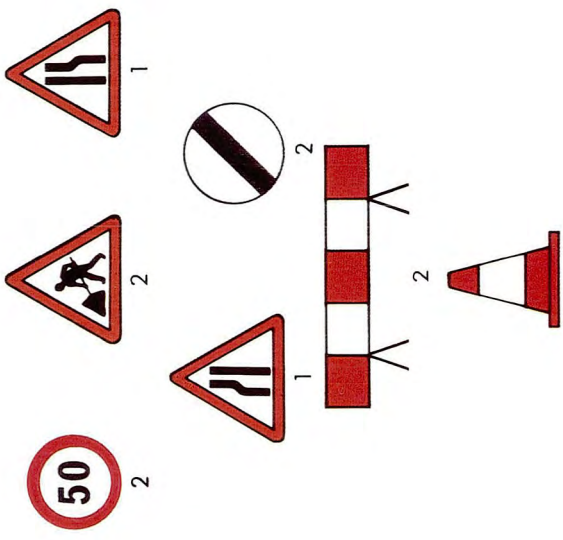



TYPICAL WORKSHEET

4. MAINTENANCE METHOD

REGRAVELLING

4.1 PRELIMINARY TASKS

Worksheet No: _____ Date: _____

District: _____ Gang: _____

Zone: _____ Road No: _____

Section: _____ from km _____ to km _____

Length: from km _____ to km _____ = _____ m

Width: _____ = _____ m

Thickness (compacted): _____ = _____ cm

Gravel: _____ trucks of _____ m³ = _____ m³

Water: _____ tankers of _____ litres = _____ litres

- The **Worksheet** should indicate the location and extent of the work to be carried out and the time, equipment and personnel required for the job.
- Where **Spot Regravelling** is specified, the extent of the sections to be regravelled should be marked out on site.





PART E - REGRAVELLING (mechanised)

Before the start of the job, a check should be made to ensure that everything needed is ready.

- Arrangements must be made to take **gravel** from the borrow pit or quarry and test it for approval. This should be done well in advance of the work.
- Arrangements must be made to obtain **water** close to the site. This should be done well in advance of the work.
- The condition and 'availability' of the equipment must be checked and the numbers of each type of equipment must be decided.
- **Trucks and plant** must be fuelled, greased, checked mechanically and have water and oil levels checked. Arrangements must be made for refuelling on site if required. This may either be with a refuelling truck visiting the working site, or by arrangement to refuel at a maintenance camp. Arrangements must be made for the necessary mechanical support on site.
- **Accommodation**
It may be necessary to make arrangements for accommodation for personnel close to the work site.
- At the beginning of the job, **traffic signs, barriers and cones** must be obtained and loaded onto a truck.

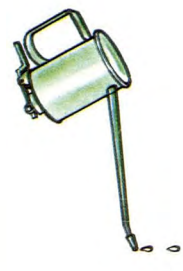
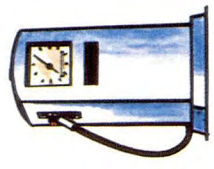
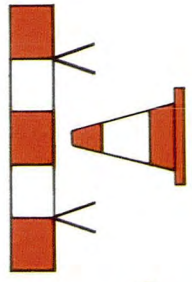



PART E - REGRAVELLING (mechanised)

■ Site Preparation

Wherever possible, before the regravelling work starts, the grader should open a **diversion** adjacent to the road.

If traffic is diverted from the work site, it will enable the job to be carried out more efficiently and safely.

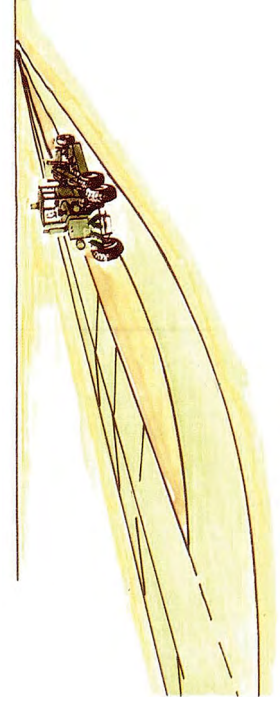

■ No Diversion

If the site conditions are such that it is not practical to build a diversion, then signs must be placed as shown for **Gravel patching (Part D)**, Pages II-90 and II-95, and working must be restricted to one side of the road at a time.

On low-traffic roads, the Maintenance Engineer may approve the use of a simpler system of traffic control.





PART E - REGRAVELLING (mechanised)

4.2 TEMPORARY SIGNPOSTING

After the diversion has been completed and before work starts, warning signs, barriers and cones must be placed around the work area.

Signs must be placed in the following order:

- **'Men Working'** signs should be placed **200 metres** in front of the work area.
- **'Turn Left/Right'** arrows should be placed **100 metres** in front of the work area.
- **Cones** should be placed diagonally across the road to lead into the diversion.
- **'Keep Left/Right'** arrows should be placed at the ends of the lines of cones.
- **Barriers** should be placed behind the lines of cones.
- **'End of Restriction'** signs should be placed **50 metres** beyond the ends of the diversion.

At **night** yellow lamps should also be used to mark the extent of the works at the diversions.

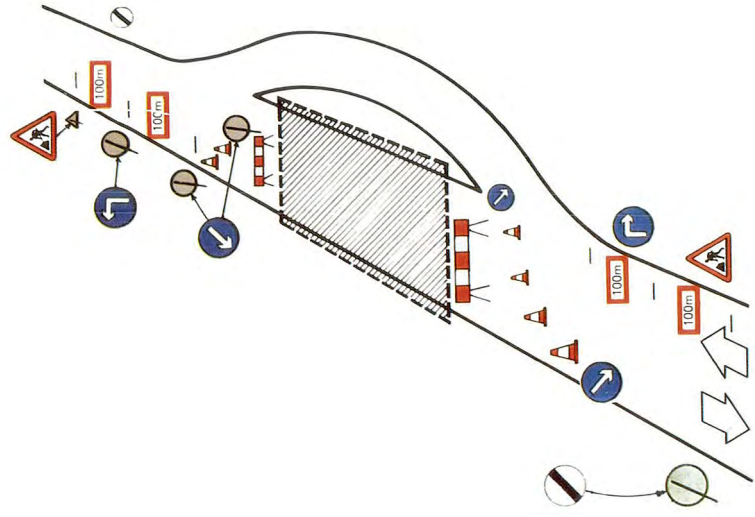

NOTE: SHOWN FOR DRIVING ON THE RIGHT





4.3 EXECUTION OF THE WORK

■ Quarry or Borrow Pit

Before the regravelling work starts, gravel should be stockpiled at the quarry or borrow pit. It may also be helpful to start hauling the material to site.

- Plan the quarry excavations and stockpiles so that:
 - the quarry can be fully exploited with removal of the maximum amount of gravel,
 - the overburden is stockpiled so that it will not hinder future extension, and that it can be used to reinstate the quarry,
 - the best material is taken, where gravel quality is variable within the quarry,
 - material is stockpiled to minimise segregation,
 - environmental damage by poor drainage and erosion is minimised both during and after exploitation of the quarry.
- The quarry layout should:
 - permit efficient excavation and stockpiling of gravel,
 - allow the trucks to enter and leave without obstructions.
- repair the quarry access road, if necessary, to ensure safe passage of trucks.

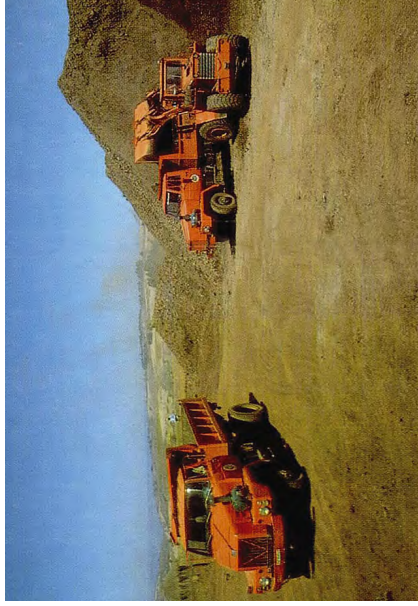



PART E - REGRAVELLING (mechanised)

After signs have been placed, the existing road surface must be **graded** as described in **Paragraph 4.3 of Part A** of this Volume.

The road surface must be graded-off to provide a firm regular surface on which to work and the edges should be 'boxed' to provide support for the new gravel. The graded surface should be watered and compacted.

The **camber*** should be checked with a camber board and the road level should fall **4 to 6 cm** for each **one metre** width of road (4-6 %).

The **drainage system** should be checked and repaired if necessary (see Volume I, Part D), otherwise the performance of the gravel surface will be affected.

At the **quarry or borrow pit**, the bulldozer should have stockpiled sufficient gravel for the work. The excavating and stockpiling of gravel should create low, broad heaps to prevent segregation of the coarser material.

When the initial grading of the road is complete, the loader should start to load the tippers with gravel for transport to the regravelling site.

The **supervisor** at the quarry should ensure that gravel is taken from the correct stockpiles and that the trucks are loaded correctly.

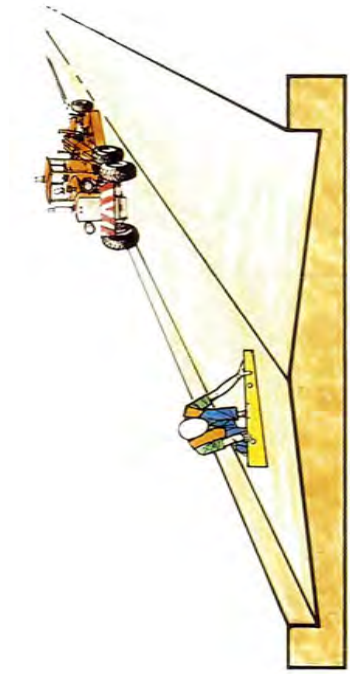

* See *List of Terms, Volume I.*



PART E - REGRAVELLING (mechanised)

- **Tipper**s should always circulate continuously between the quarry and the site.
- Dumping should start at the far end of the site so that the heaps of gravel do not impede tipper's delivering later loads.
- Material should be dumped on one side of the road only. Loads should be placed at the correct spacing as instructed by the Maintenance Engineer, necessary to give the required thickness of gravel over the complete road width.
- If the road is not closed, material should be dumped on the shoulder.
- The **tankers** should have filled up with water using the **pump** and then have driven to the site.

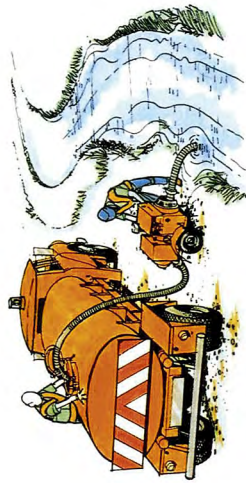
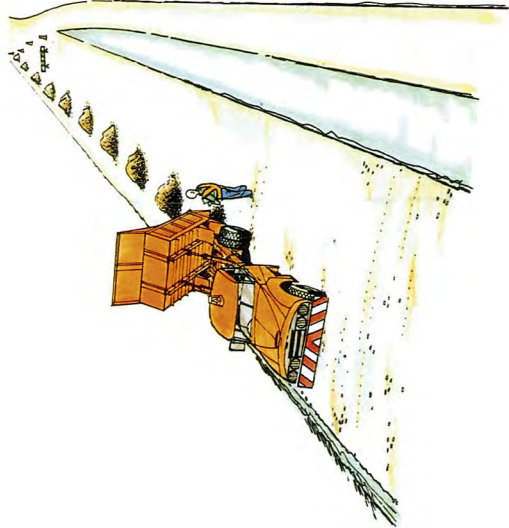



PART E - REGRAVELLING (mechanised)

- Spreading of the gravel can start when there is a working length of at least **200 metres** of dumped material.
- Initially the road is sprayed with water.
- The regravelling material is then spread right across the road using the **grader**.

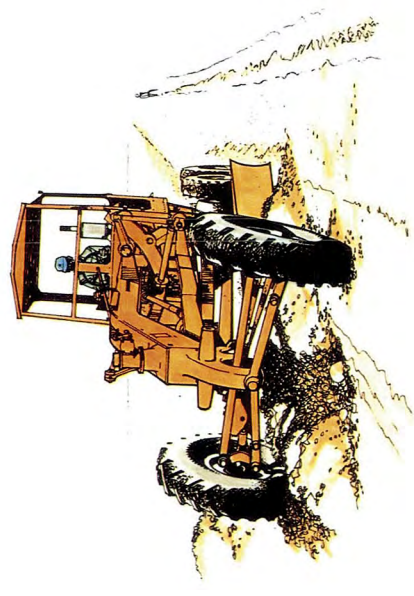
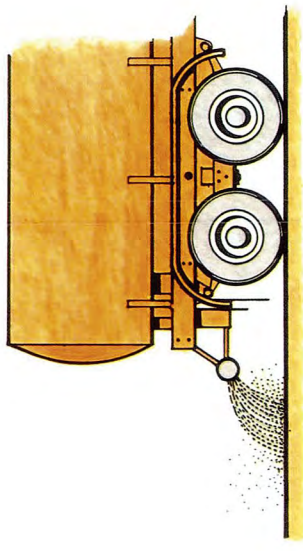



PART E - REGRAVELLING (mechanised)

- The material is alternately spread by the grader and watered with the tanker until its moisture content is correct for compaction*.

The amount of water to be added must be determined by moisture content tests on site or by the **Maintenance Engineer**.

- The tankers circulate continuously between the site and the source of water.

- The new material is now **graded** as described in Paragraph 4.3 of Part A (Page II-16) of this Volume to produce a camber* of **4 to 6** cm for each **one metre** width of road (4 to 6 %).

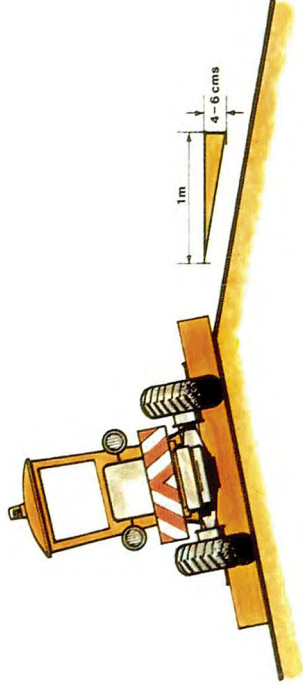

* See List of Terms, Volume I.





PART E - REGRAVELLING (mechanised)

- **The camber*** should now be checked with the camber board at approximately 100 metre intervals along the road.

- **To use the camber board**
Place it on its edge across the road with the shorter end pointing towards the centre line.

Check the level bubble

If it is central, the camber is correct.
If it is not central, the camber is either too steep or flat and further grading and compaction are required.

- If the camber does **not** fall 4 to 6 cm for each **one metre** width of straight road, the grading must be **repeated**.

* See List of Terms, Volume I.

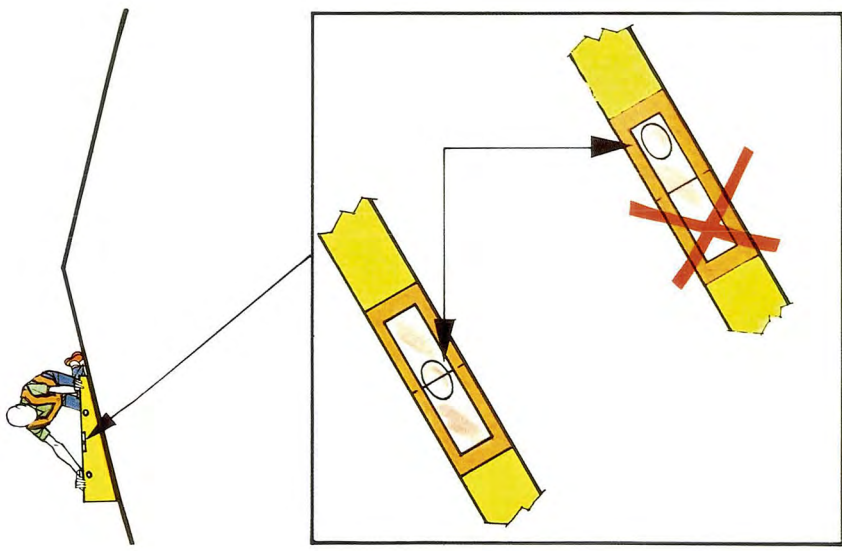



PART E - REGRAVELLING (mechanised)

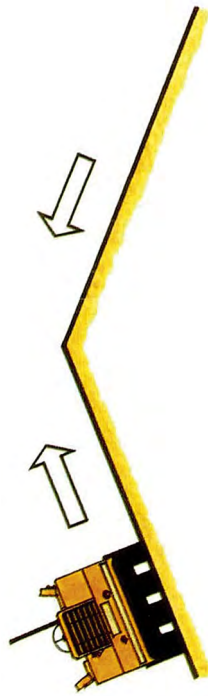

- When the correct camber* has been achieved, **rolling** can start.
Water should not be added during rolling as the material may stick to the wheels or drums.
Rolling should start at the edge of the road and work towards the middle. The roller should aim to progress from section to section at the same rate as the grader.
About eight passes of the roller will be needed to achieve full compaction.



It is possible to regravell without the use of water and compaction, **but it is difficult to achieve satisfactory results.**

* See List of Terms, Volume I.





4.4 COMPLETION AND REMOVAL OF TEMPORARY SIGNS

The work proceeds along the road in sections. As each section is completed, the traffic signs, cones and barriers are moved along the road. This opens the road at the completed end for traffic, and closes it at the other end to allow new gravel to be dumped.

As work proceeds, it will be necessary to open new diversions and move the diversion signs.

When the work is finally completed,

- Remove the traffic signs, cones and barriers and load them onto the truck in the following order:

- 1 'End of Restriction' signs,
- 2 Barriers,
- 3 'Keep Left/Right' arrows,
- 4 Cones,
- 5 'Turn Left/Right' arrows,
- 6 'Men Working' signs.

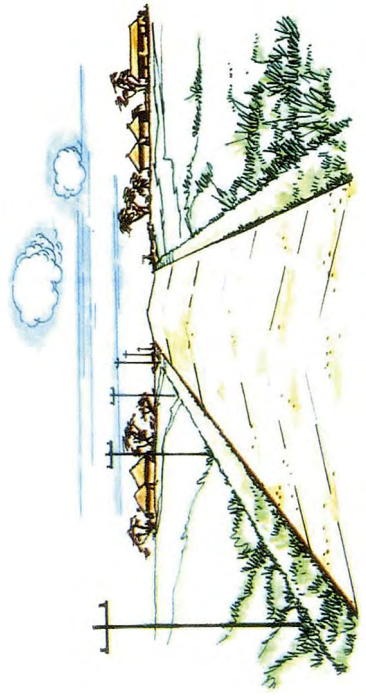



PART E - REGRAVELLING (mechanised)

- Ensure that the site is left clean and tidy with no stockpiles of material left on the road.
- Move on to the next job.
- Inspect traffic signs and clean if necessary.





PART E - REGRAVELLING (mechanised)

TYPICAL WORK REPORT

REGRAVELLING

Work Report No: _____ Date: _____
District: _____ Gang: _____
Zone: _____ Road No: _____
Section: _____ from km _____ to km _____

WEATHER CONDITIONS:

Sunny Cloudy Rain

QUANTITY OF WORK ACHIEVED:

Length: from km _____ to km _____ = _____ m
Width: _____ = _____ m
Thickness (compacted): _____ = _____ cm
Gravel: _____ trucks of _____ m³ = _____ m³
Water: _____ tankers of _____ litres = _____ litres

EQUIPMENT USED:

_____ Hrs _____ litres
_____ Hrs _____ litres
_____ Hrs _____ litres

MANPOWER USED: _____

COMMENTS: _____

Foreman: _____

4.5 WORK REPORT

The report must be filled in **each day**, detailing:

- the work carried out,
- the resources used.





Part F

REGRAVELLING

(Labour and Tractors)





PART F - REGRAVELLING (Labour and Tractors)





PART F - REGRAVELLING (Labour and Tractors)

LABOUR AND TRACTOR REGRAVELLING

Mechanised Regravelling, as described in Part E, is the most commonly used technique for the renewal of a gravel running surface.

However in certain circumstances, the high cost or non availability of the specialist equipment make **Labour and Tractor Regravelling** a more appropriate option.

In this case use is made of local labour to excavate and load gravel at the quarry, and unload and spread the material at the road site.

Haulage is carried out by agricultural tractors of 45 hp (34 kW) or greater, and gravel trailers.

Compaction is provided by tractor drawn rollers, or by the use of the loaded trailers.

This method is usually appropriate for gravel hauls up to about 10 km.

In areas where animal traction is established, the gravel may usually be hauled economically for distances up to about 3 km using small carts.

For haulage distances greater than 10 km trucks are usually more economical. However these may be loaded manually.





PART F - REGRAVELLING (Labour and Tractors)

1. THE TASK



The surfacing material of unpaved roads is worn away by traffic, eroded by rain and blown away as dust.

Before all the gravel surfacing has worn away the road requires **regravelling**.

Regravelling is normally a **PERIODIC MAINTENANCE** task.

It is important that the **Maintenance Engineer** plans regravelling work well in advance so that work is carried out before serious defects appear.

Before regravelling is carried out, it is important to make any necessary repairs or improvements to the **camber** and **drainage system** of the road. If this is not done, the new gravel surface will deteriorate very quickly.

Regravelling is normally carried out with one layer of 15 cm thickness.

Usually a continuous layer of gravel is laid on the existing running surface, however on some occasions only short stretches showing severe defects are covered under a **spot regravelling** operation.

This Part describes **Regravelling using Labour and Tractor** methods.

Mechanised regravelling using heavy plant is described in Part E (Page II-113).





PART F - REGRAVELLING (Labour and Tractors)

2. DEFECTS

Regravelling is used to correct

- Loss of surfacing material

Regravelling is needed before the subgrade* is exposed on the road surface. This will be evident particularly in ruts and depressions.

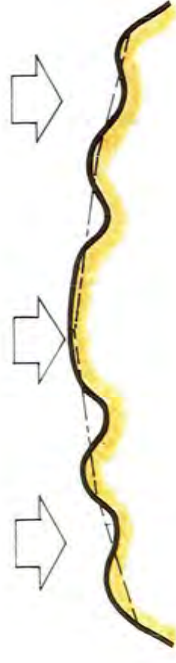

Regravelling is also used to correct

- Loss of shape
- Ruts
- Potholes
- Erosion Gullies

When these are severe.

In these cases reshaping (Part B) is carried out before the regravelling operation.

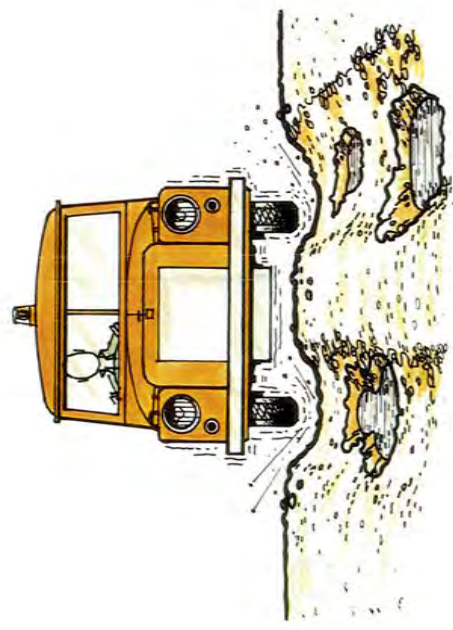

* See List of Terms, Volume I.





REGRAVELLING PLANNING GUIDELINES

(Assumes good haul routes, 45 - 75 HP (34 - 56 kW) tractors, 3 m³ trailers and the productivities shown on Page II - 153).

HAUL DISTANCE Km	NUMBER OF TRANSACTIONS	QUANTITY OF GRAVEL HAULED m ³ /DAY (LOOSE)	EQUIVALENT LENGTH OF GRAVELLED ROAD METRES/DAY		APPROX. LABOUR FORCE REQUIRED (EXCAVATION, LOADING, UNLOADING AND SPREADING ONLY)	
			0.4m ³ /m RUN COMPACTED			
			0.65m ³ /m RUN COMPACTED **	0.9m ³ /m RUN COMPACTED ***		
0 - 1	2	126	252	156	112	63 - 90
1 - 2	2	108	216	133	96	54 - 77
	3	162	324	200	144	81 - 115
2 - 3	2	78	156	96	70	39 - 56
	3	117	234	144	104	59 - 83
3 - 4	4	156	312	193	139	78 - 111
	3	90	180	111	80	45 - 64
4 - 5	4	120	240	148	107	60 - 85
	5	150	300	185	134	75 - 107
4 - 5	4	108	216	133	96	54 - 77
	5	135	270	167	120	67 - 96
5 - 6	6	162	324	200	144	81 - 115
	4	84	168	104	75	42 - 60
5 - 6	5	105	210	130	94	53 - 75
	6	126	252	156	112	63 - 90
6 - 7	7	147	294	181	131	73 - 105
	4	72	144	89	64	36 - 51
5 - 6	5	90	180	111	80	45 - 64
	6	108	216	133	96	54 - 77
6 - 7	7	126	252	156	112	63 - 90

Continued below

3. RESOURCES

3.1 PERSONNEL

- **Supervisors**
 - 1 foreman or overseer at the quarry,
 - 1 overseer at the road site.
- **Plant Operators and Drivers**
 - 1 driver for each tractor.
- **Workforce**
 - depending on number of tractors, haul distance and labour productivity.
- **Support (as necessary)**
 - mechanics for daily servicing and repair,
 - water carriers,
 - storeman,
 - watchmen,
 - handtool sharpening and repairs.



PART F - REGRAVELLING (Labour and Tractors)

Continued from above

HAUL DISTANCE KM	NUMBER OF TRANSACTIONS	QUANTITY OF GRAVEL HAULED m ³ /DAY (LOOSE)	EQUIVALENT LENGTH OF GRAVELLED ROAD METRES/DAY				APPROX. LABOUR FORCE REQUIRED (EXCAVATION, LOADING, UNLOADING AND SPREADING ONLY)
			0.4m ³ /m RUN COMPACTED		0.9m ³ /m RUN COMPACTED		
			*	**	**	***	
7 - 8	4	72	144	89	64	36 - 51	
	5	90	180	111	80	45 - 64	
	6	108	216	133	96	54 - 77	
	7	126	252	156	112	63 - 90	
8 - 9	4	60	120	74	54	30 - 43	
	5	75	150	93	67	38 - 54	
	6	90	180	111	80	45 - 64	
	7	105	210	130	94	53 - 75	
9 - 10	4	48	96	59	43	24 - 34	
	5	60	120	74	54	30 - 43	
	6	72	144	89	64	36 - 51	
	7	84	168	104	75	42 - 60	

* e.g. 4.0 metres wide and 10 cms thick

** 5.4 metres wide and 12 cms thick

*** 6.0 metres wide and 15 cms thick





PART F - REGRAVELLING (Labour and Tractors)

3.2 PLANT AND TOOLS

■ **Tractors**

The number of tractors required will depend on the gravel haul distance and plant availability.

The Table on Page II-144 gives guidelines on the number of working tractor and labour resources required for hauling gravel over various distances.

Additional tractors may be required for hauling rollers, water and fuel.

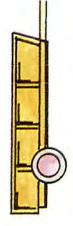
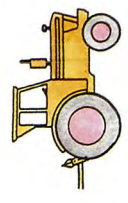

■ **Trailers**

- 2 trailers per tractor if possible.

This allows one trailer to be filled while the other is hauled to the road site.

3 m³ capacity trailers are most suitable for 45 to 75 hp (34 to 56 kW) tractors.

■ **Other Items**

- 1 towed deadweight roller or hand operated vibrating roller,
- 1 towed water bowser,
- 1 towed fuel bowser,
- light vehicle(s) for the transport of the two supervisors.





PART F - REGRAVELLING (Labour and Tractors)

■ Tools

Typical handtool requirements for a workforce of up to 100 labourers.

- 70 shovels,
- 20 hoes,
- 50 mattocks,
- 50 pickaxes,
- 10 bushknives,
- 5 wheelbarrows,
- 8 crowbars,
- 20 rakes,
- sledgehammers,
- 2 tape measures (30 m),
- 10 buckets,
- water containers,
- camber board and spirit level,
- 2 mason's hammers,
- wooden pegs,
- balls of string/sisal twine,
- 4 files (for sharpening tools).



3.3 MATERIALS

- Gravel obtained from a quarry or gravel pit must be of a quality that meets the Departmental specifications and also be approved by the **Maintenance Engineer**.





PART F - REGRAVELLING (Labour and Tractors)

3.4 SUPPORT AND SAFETY ARRANGEMENTS

Arrangements should be made, as necessary, for the following:-

- **Recruitment** of workmen if employed casually.
- **Setting up temporary site camps**
 - supervisors' accommodation and facilities,
 - secure handtool storage,
 - water supply.

■ **Payment** of wages.

■ **Signs and Safety Equipment.**

When working on a low traffic volume road open to traffic, signs and safety equipment detailed in Part D (Patching, Method A), Page II-90 and II-95 should be used.

When closing the road and providing a diversion, the signs and safety equipment detailed in Part E (Mechanised Regravelling), Pages II-122/123/124 and II-128 should be used.





PART F - REGRAVELLING (Labour and Tractors)

TYPICAL WORKSHEET

4. MAINTENANCE METHOD

REGRAVELLING

4.1 PRELIMINARY TASKS

Worksheet No: _____ Date: _____

District: _____ Gang: _____

Zone: _____ Road No: _____

Section: _____ from km _____ to km _____

Length: from km _____ to km _____ = _____ m

Width: _____ = _____ m

Thickness (compacted): _____ = _____ cm

Gravel: _____ trailers of _____ m = _____ m

Water: _____ tankers of _____ litres = _____ litres

■ **The Worksheet** will indicate the location and extent of the work to be carried out and the time, equipment and personnel required for the job.

■ Where **Spot Regravelling** is specified, the extent of the sections to be regravelled should be marked out on site.





PART F - REGRAVELLING (Labour and Tractors)



Before the start of the job, a check should be made to ensure that everything is arranged as necessary.

- Identify gravel source, test material and make any acquisition arrangements.
- Ensure adequate quantities of gravel are available for the job.
- Recruit or inform local labour force.
- Set up temporary site camp for supervisors.
- Set up water supply arrangements.
- Plan payment arrangements.
- Tractors must be fuelled and have their water and oil levels checked. All items of plant must be greased and checked mechanically.
- Arrangements must be made for refuelling on site and the necessary mechanical support.





PART F - REGRAVELLING (Labour and Tractors)

■ Site Preparation

Wherever possible, before the regravelling work starts, a **diversion** should be constructed adjacent to the road. It can normally be of earth road standard.

If traffic is diverted from the work site, it will enable the job to be carried out more efficiently and safely.





PART F - REGRAVELLING (Labour and Tractors)

4.2 TEMPORARY SIGNPOSTING

When working on a low traffic volume road open to traffic, the signs and safety equipment should be deployed as shown in paragraph 4.2 of Part D (Page II-95).

When closing the road and providing a diversion, the signs and safety equipment should be deployed as shown in paragraph 4.2 of Part E (Page II-128).

On low traffic volume roads, the Maintenance Engineer may approve the use of a simpler system of traffic control.

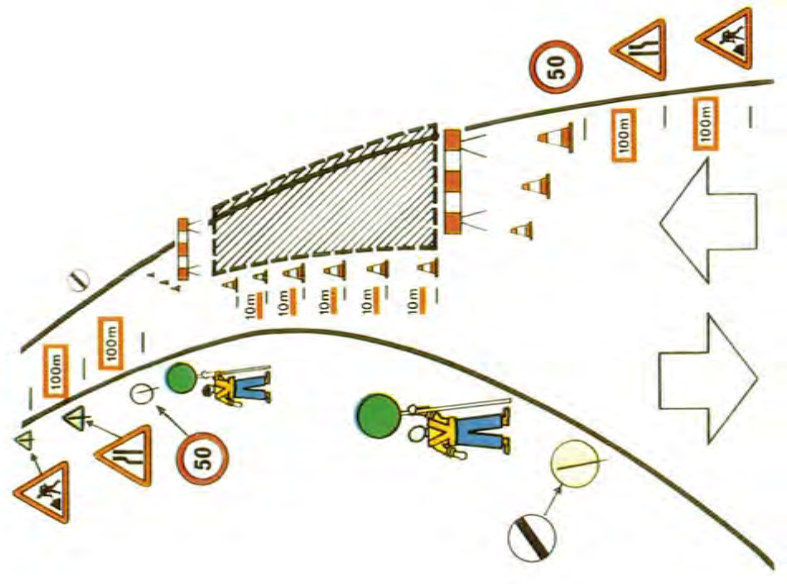

NOTE: SHOWN FOR DRIVING ON THE RIGHT





PART F - REGRAVELLING (Labour and Tractors)

TYPICAL PRODUCTIVITY TARGETS

ACTIVITY	TASK RATE	
RESHAPING ROAD	20 - 50 m/MANDAY	
CLEARING BUSH	200-1000 m ² /MANDAY	
EXCAVATING OVERBURDEN + LOADING ONTO WHEELBARROW IF NECESSARY	2 - 4 m ³ /MANDAY	
HAULING OVERBURDEN BY WHEELBARROW *	QUANTITY	NO OF TRIPS/DAY
	0 - 40m	210
	40 - 60m	160
	60 - 80m	130
80 - 100m	5.5 m ³ /MANDAY	110
EXCAVATING GRAVEL	1.6 - 2.4 m ³ /MANDAY (INSITU) 2 - 3 m ³ /MANDAY (LOOSE)	
LOADING GRAVEL	8-10 m ³ /MANDAY (LOOSE)	
OFFLOADING AND SPREADING	12 - 16 m ³ /MANDAY (LOOSE)	

***NOTES:**

- Targets for hauling and tipping only; excludes loading and spreading.
- Assuming wheelbarrow volume equivalent to 0.05 cum of compacted/insitu material (0.07cum loose) when struck level with top of bodywork.
- 2 wheelbarrows assigned to each hauling labourer.
- Good haul route (Reduce targets for poor haul route).

4.3 EXECUTION OF THE WORK

The following steps are normally required:

- DAILY PLANNING
- PREPARATION OF ROAD SURFACE
- PREPARATION OF QUARRY/ACCESS ROAD
- GRAVEL EXCAVATION AND STOCKPILING
- LOADING
- HAULING
- OFFLOADING AND SPREADING
- COMPACTION
- STOCKPILING GRAVEL FOR ROUTINE MAINTENANCE

When using a large labour force, it is essential to break the work down into simple manageable operations to achieve satisfactory productivity and quality.



PART F - REGRAVELLING (Labour and Tractors)

DAILY PLANNING

The deployment of tractors and trailers and the number of labourers for each activity depend on:

- quantity of gravel already stockpiled,
- the haul distance,
- number of serviceable tractors and trailers,
- tractor power,
- haul route condition.

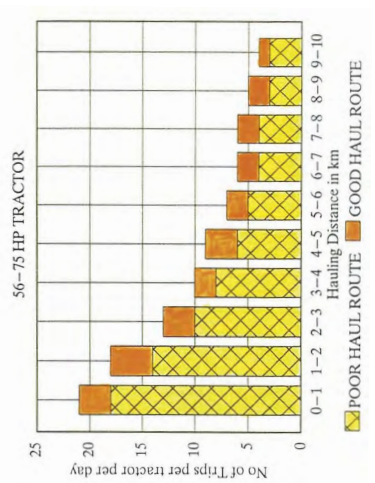
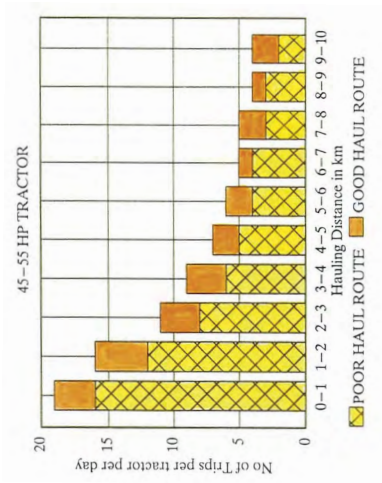



PART F - REGRAVELLING (Labour and Tractors)

The plans for each day should be prepared at the end of the preceding day's work.
Tasks should be set based on local experience, however the typical targets shown on Page II-153 may be used as a guideline.

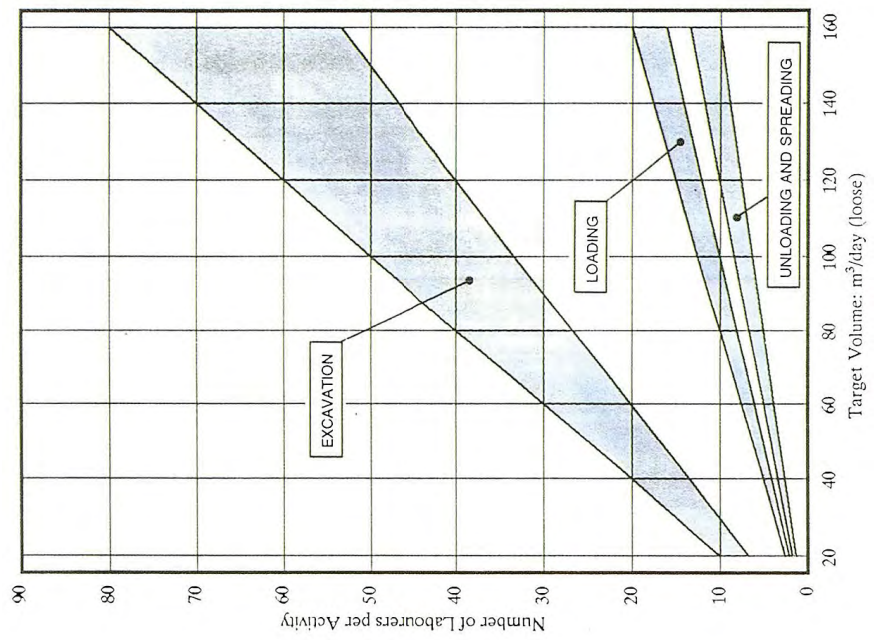



PART F - REGRAVELLING (Labour and Tractors)

PREPARATION OF SURFACE

After signs have been placed, the existing surface should be **reshaped** to the correct camber as described in Part B of this Volume.

If possible, the reshaped surface should be compacted.

The **camber*** should be checked with a camber board and spirit level. The road level should fall 4 to 6 cm for each one metre width of road (4 to 6 %).

The **drainage system** should be checked and repaired if necessary (see Volume I). Otherwise the performance of the gravel surface will be affected.



* See List of Terms, Volume I.



PART F - REGRAVELLING (Labour and Tractors)

PREPARATION OF QUARRY AND ACCESS

- Plan the quarry excavations and stockpiles so that:
 - the quarry can be fully exploited with removal of the maximum amount of gravel,
 - the overburden is stockpiled so that it will not hinder future extension, and that it can be used to reinstate the quarry,
 - the best material is taken, where gravel quality is variable within the quarry,
 - environmental damage by poor drainage and erosion is minimised both during and after exploitation of the quarry.
- The quarry layout should:
 - permit efficient excavation and stockpiling of gravel,
 - allow the tractors and trailers to enter and leave without obstructions.
- Repair the quarry access road, if necessary, to ensure safe passage of tractors and trailers.





PART F - REGRAVELLING (Labour and Tractors)

DEVELOPMENT OF QUARRY ON FLAT LAND

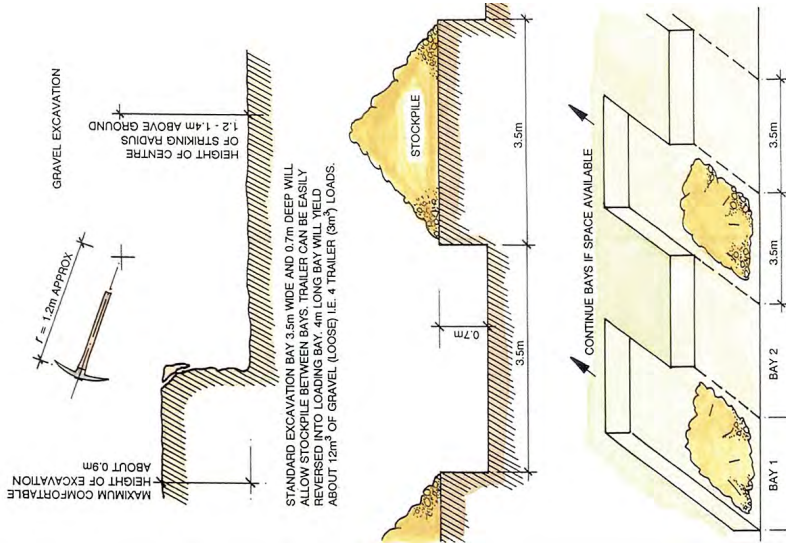

GRAVEL EXCAVATION AND STOCKPILING

- Gravel should be excavated and stockpiled at least one day before it is required to be hauled.
- Gravel should be excavated and stockpiled alongside to allow easy loading and avoid multiple handling.
- Where possible excavate bays, using gang tasks, so that trailers can be backed in for loading.
- Ramps into loading bays must not be too steep for tractors hauling loaded trailers.





PART F - REGRAVELLING (Labour and Tractors)

TYPICAL DEVELOPMENT OF HILLSIDE QUARRY

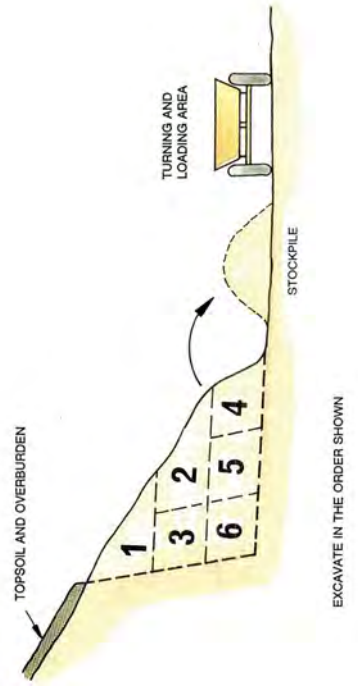

- In hillside quarries, excavate material to ease loading and ensure safety of workmen.
- Workmen must have enough room to work safely and comfortably.
- Sufficient room must be allowed for turning tractors and trailers.





PART F - REGRAVELLING (Labour and Tractors)

TRAILER LOADING HEIGHT

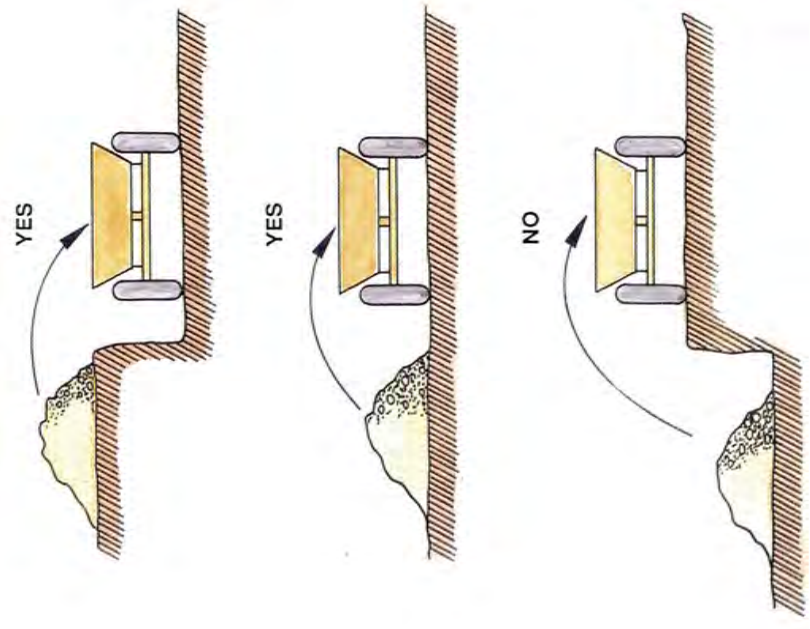

LOADING

Where possible trailers should be parked at the same height as, or preferably below, stockpiles for ease of loading.
The loading gang should be divided into groups of 4 to 6 workmen. These groups load the empty trailers in the order in which they arrive at the quarry.
All trailers must be loaded to the correct load line.





PART F - REGRAVELLING (Labour and Tractors)

TRACTOR – TRAILER HAULING

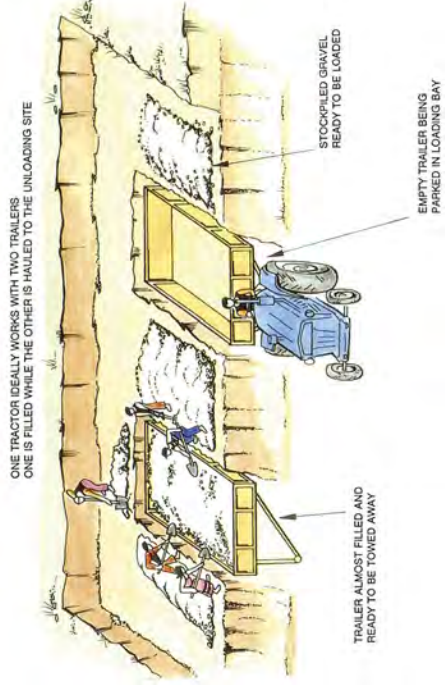

HAULING

- Gravelling should commence from where the quarry access joins the road to be regravelled.
- Initially the road should be gravelled away from the quarry access in both directions simultaneously. With short hauls this will reduce congestion at the unloading sites.
- When hauls exceed about 1 km, gravelling should continue only in one direction at a time.

The advantages are:

- the tractors and trailers compact the material as they haul over the already laid gravel,
- damage to existing road camber is minimised,
- gravelling traffic does not interfere with reshaping activities,
- gravelling can recommence sooner after rainfall.

- Ideally one tractor works with two trailers to maximise use of the tractor,





PART F - REGRAVELLING (Labour and Tractors)

OFFLOADING AND SPREADING



- It is important to off load the trailers as quickly as possible.
- Usually no more than 4 workmen can comfortably work on a trailer at a time.
- The material from one trailer is unloaded and spread within a 'box' marked out by pegs and string/sisal twine. The pegs are set at the finished road level with the aid of the camber board and spirit level.
- Any gravel lumps or stones larger than 5 cm should be broken down using sledge hammers, or removed.





PART F - REGRAVELLING (Labour and Tractors)

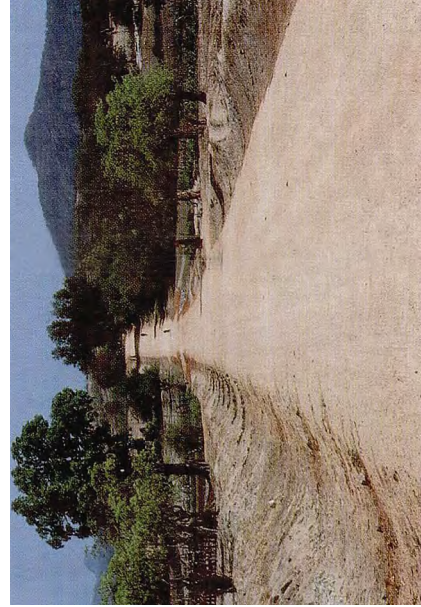

COMPACTION

- If available, the gravel layer should be watered using the towed water bowser before compaction.
- If available, compaction should be carried out with a tractor drawn deadweight roller or a hand operated vibrating roller.
- If compaction equipment is not available, some consolidation can be achieved by driving the loaded trailers over the freshly laid material. The drivers should be instructed to drive on different parts of the roadway with each pass.





PART F - REGRAVELLING (Labour and Tractors)

STOCKPILING GRAVEL FOR ROUTINE MAINTENANCE

- If attendants or lengthmen are used for follow up routine maintenance, gravel stockpiles should be provided for patching activities.
- Where possible, gravel stockpiles of one trailer load should be placed at 100 to 200 m intervals along the road.
- The stockpiles should be placed well clear of the road and outside the side drains.
- Where there is no space in the road reserve, the stockpile should be placed in the side drain **immediately downhill** of a turnout drain to avoid blocking the drainage system.

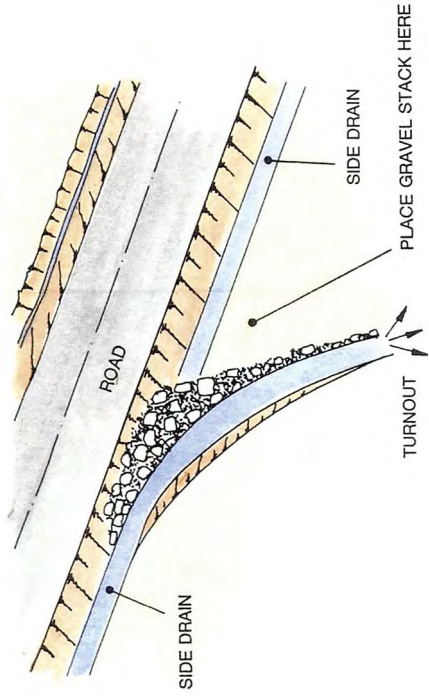



PART F - REGRAVELLING (Labour and Tractors)

4.4 COMPLETION AND REMOVAL OF TEMPORARY SIGNS

On completion of the work the temporary signs and safety equipment are removed as described in Parts D, (Page II-102) or E, (Page II-136) as applicable.

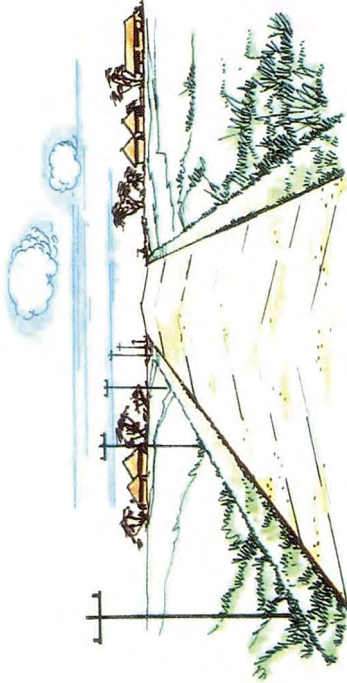



PART F - REGRAVELLING (Labour and Tractors)

TYPICAL WORK REPORT

REGRAVELLING

Work Report No: _____ Date: _____
 District: _____ Gang: _____
 Zone: _____ Road No: _____
 Section: _____ from km _____ to km _____

WEATHER CONDITIONS:

Sunny Cloudy Rain

QUANTITY OF WORK ACHIEVED:

Length: from km _____ to km _____ = _____ m
 Width: _____ = _____ m
 Thickness (compacted): _____ = _____ cm
 Gravel: _____ trailers of _____ m³ = _____ m³
 Water: _____ tankers of _____ litres = _____ litres

EQUIPMENT USED: DIESEL USED:

_____ Hrs _____ litres
 _____ Hrs _____ litres
 _____ Hrs _____ litres

MANPOWER USED:

COMMENTS:

 Foreman: _____

4.5 WORK REPORT

- The report must be filled in **each day**, detailing
 - the work carried out,
 - the resources used.





Notes and Sketches

A large rectangular area containing 14 horizontal lines, intended for writing notes or sketches.



II-167





User of this Handbook:

NAME: _____

ADDRESS: _____

DATE: _____





INDEX OF VOLUME II

INDEX OF VOLUME II

B

Bends II-23

Blade Position II-26

Borrow Pit..... II-129

Bridge Deck..... II-25

C

Camber Formation II-58

Camber II-22

Camber II-130

Camber II-134

Camber II-156

Compaction II-135

Compaction II-163

Compaction II-58

Compaction II-21

Corrugations..... II-39

Corrugations..... II-6

Crossfall II-19

Crown II-19

Culverts II-25

Curves II-23

D

Daily Planning II-154

Ditch, Grade II-29

Diversion II-128

Diversion II-124

Dragging..... II-61

Dragging, Graders..... II-75

Dragging, Tractors II-72

Drags II-67

E

Erosion Gullies II-116

Erosion Gullies II-143

Erosion Gullies II-39

Erosion Gullies II-84

Erosion Gullies II-6

Excavation II-56

G

Grade Ditch II-29

Grading II-1

Grading, Heavy II-17

Grading, Light..... II-17

Gravel Excavation II-158

Gravel Extraction II-158

Gravel Loss II-143

Gravel Loss II-116

Gravel Material..... II-147

Gravel Material II-121

Gravel, Patching..... II-108

Gravel, Patching..... II-97

Gravel, Patching..... II-89

L

Labour Based Patching II-105

Labour Based Reshaping..... II-35

Loading II-160

Loss of Shape II-116

Loss of Shape II-143

Loss of Shape II-39

Loss of Shape II-5

O

Off Loading..... II-162

P

Patching II-81

Planning (Table)..... II-144

Potholes II-116

Potholes II-143

Potholes II-39

Potholes II-84

Preparation..... II-156

Productivity (Table) II-153

II-169

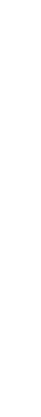



INDEX OF VOLUME II

	Page		Page
Q		W	
Quarry Preparation	II-157	Windrow	II-76
Quarry	II-129	Windrow	II-27
R			
Regravelling (Mechanised) ..	II-113		
Ruts	II-116		
Ruts	II-143		
Ruts	II-39		
Ruts	II-84		
Ruts	II-5		
S			
Setting Out	II-52		
Silted/Blocked Ditches	II-39		
Silted/Blocked Ditches	II-6		
Soft Spots	II-84		
Spot Regravelling	II-142		
Spot Regravelling	II-115		
Spreading	II-162		
Stockpiling Gravel	II-158		
Stockpiling Gravel	II-153		
Superelevation	II-23		
Support	II-148		
Support	II-120		
T			
Tractors	II-139		
Turnouts	II-31		



ACKNOWLEDGEMENTS (Second Edition)

The contents of this handbook draw on many sources, past and present, and it would be impossible to acknowledge them all individually. Much of the material is an updating of the UNECA Maintenance Handbook for Africa, compiled by experts from France, Germany and the United Kingdom, and published in 1982. Its three volumes encapsulated the broad experience of highway engineers, maintenance managers, consultants and researchers from many different countries.

The present revision was undertaken by Mr R.C. Petts of Intech Associates, in close association with the Overseas Centre of the Transport Research Laboratory. The work was funded by the UK Overseas Development Administration and supported and guided by a subcommittee drawn from the PIARC Committee on Technology Transfer and Development (C3). It benefited from the collective wisdom of that committee and the countries represented within it. These included Australia, Algeria, Belgium, Brazil, Burkino Faso, France, Germany, India, Italy, Morocco, Poland, Portugal, Senegal, Spain, Turkey, the United States of America, the United Kingdom and the World Bank.

On behalf of the subcommittee I would like to record our sincere thanks to all those who contributed, in whatever way, to the production of this second version of the Maintenance Handbook and to making it more valuable to a wider international audience. I am sure it will fulfil its intended purpose of strengthening the capabilities of maintenance workforces and giving them a stronger sense of professional pride in the vital work they are doing.





ACKNOWLEDGEMENTS (Second Edition) continued

Any revision of this kind is an ongoing process, and comments or suggestions for further improvements should be made known to the PIARC Central Office at 27 rue Guenegaud, 75006, PARIS, France. Fax:+33 (1)46 33 84 60.

J. Stuart Yerrell Chairman,
Subcommittee C3-6d
1994

ACKNOWLEDGEMENTS (Third Edition)

Funding for publishing this edition has been made available by the UK Department for International Development (DFID) through the 'global Transport Knowledge Partnership (gTKP)', (www.gtkp.com)



WHAT IS PIARC?

Origins

Founded in 1909 following the 1st International Road Congress held in Paris in 1908, the Permanent International Association of Road Congresses (PIARC) is the oldest of the international associations concerned with roads and road engineering.

Vision

PIARC will be the world leader in the exchange of knowledge on roads and road transport policy and practices within an integrated sustainable transport context.

Mission

PIARC exists to serve all its members by:

- being a leading international forum for analysis and discussion of the full spectrum of transport issues, related to roads and road transport,
- identifying, developing and disseminating best practice and giving better access to international information,
- fully considering within its activities the needs of developing countries and countries in transition,
- developing and promoting efficient tools for decision making on matters related to roads and road transport.

Values

PIARC's values are:

- to provide universal quality service to its members,
- to be open, objective and impartial,





- to promote sustainable and sound economic solutions,
- to recognise road transport in an integrated transport and land use context,
- to be customer driven,
- to respect the differing international road transport needs.

Activities

To achieve these aims, PIARC:

- creates and coordinates Technical Committees,
- organizes a quadrennial World Road Congress, a quadrennial Winter Road Congress and various technical seminars and
- publishes a large number of documents including a quarterly magazine ('Routes/Roads').

Strategic plan

A strategic plan guides PIARC activities. For the period 2004-2007 there are four strategic themes which cover the work of 18 Technical Committees. These are:

- ST1 Governance and management of the road system
 - 1.1 Road system economics
 - 1.2 Financing road system investment
 - 1.3 Performance of road administrations
 - 1.4 Management of network operations

ST2 Sustainable mobility

- 2.1 Sustainable development and road transport
- 2.2 Inter-urban roads and integrated inter-urban transport
- 2.3 Urban areas and integrated urban transport
- 2.4 Freight transport and intermodality
- 2.5 Rural roads and accessibility

ST3 Safety and road operations

- 3.1 Road safety
- 3.2 Risk management for roads
- 3.3 Road tunnels operations
- 3.4 Winter maintenance

ST4 Quality of road infrastructures

- 4.1 Management of road infrastructure assets
- 4.2 Road/vehicle interaction
- 4.3 Road pavements
- 4.4 Bridges and related structures
- 4.5 Earthworks, drainage and subgrade

PIARC has strong links with several regional organisations and is in favour of networking between countries dealing with similar questions. PIARC may help to create and/or develop such networks.

PIARC Committees and Working Groups are composed of engineers and experts appointed by member countries. They act on a continuous basis between each Congress and participate in international meetings dealing with subjects within their competence:





- **PIARC PUBLICATIONS** - Committees and Working Groups publish synthetic documents recommendations and state of the art. These documents intended for decision makers, design and field engineers and researchers, are based on wide international consensus
- **CONGRESS DOCUMENTS** - The documents published on the occasion of World Road Congresses are an invaluable source of information and experts agree on the fact that they are most interesting and unique.
- **PERIODICAL BULLETIN 'Routes/Roads'** - The Association Bulletin was issued for the first time in 1911. It features comprehensive files on road matters in various countries, articles written by members of Committees and Working Groups and news of interest to the world road community. Its issues of a hundred pages are published three to four times a year.
- **TECHNICAL DICTIONARY OF ROAD TERMS AND LEXICON** - The first edition of the DICTIONARY was issued in 1931. The sixth edition (French/English) was published in 1990. The Dictionary is published with the financial support of UNESCO and is translated into eighteen languages: Arabic, Chinese, Croatian, Czech, Danish, Dutch, German, Greek, Hungarian, Italian, Japanese, Lithuanian, Polish, Portuguese, Romanian, Russian, Spanish and Slovak. The Lexicon contains over 12,000 expressions in English and French and is also available on computer disk.



All these documents are published in French and English.
PIARC publications catalogue is free of charge and can be ordered through:

ANR TP
32, rue du Marché commun
Centre de Gros - Case postale 1220
44082 NANTES Cedex 03 (FRANCE)
Fax:+33 40 50 13 64





WHERE TO ORDER THE HANDBOOK

The English version of

- Volume I: Maintenance of Roadside Areas and Drainage
- Volume II: Maintenance of Unpaved Roads
- Volume III: Maintenance of Paved Roads
- Volume IV: Maintenance of Structures and Traffic Control Devices

may be ordered from:

TRL Limited, Crowthorne House, Nine Mile Ride, Wokingham, Berkshire,
RG40 3GA, United Kingdom.

Fax: +44 (0) 1344 770356

Phone: +44 (0) 1344 773131

Email: international_enquiries@trl.co.uk

Website: www.trl.co.uk



The Road Maintenance Handbook is also being published in French, Spanish and Portuguese. Other languages are under consideration. For more details, please contact PIARC Central Office – La Grande Arche, Paroi Nord, Niveau 5, 92055, La Défense Cédex, France.

Fax: +33 1 49 00 02 02

Phone: +33 1 47 96 81 21

Email: piarc@wanadoo.fr

Website: www.piarc.org

