

contractor's handbook

labour-based road works



Republic of Zambia
Ministry of Works and Supply
Roads Department, Roads Training School

Contractor's Handbook for Labour-Based Road Works

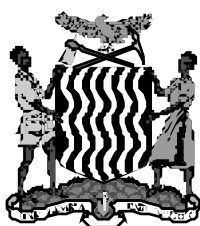

Republic of Zambia

**Ministry of Works and Supply
Roads Department
Roads Department Training School**



**International Labour Organisation
ASIST
Advisory Support Information Services and Training**

**This manual has been produced with financial support from the
Norwegian Agency for Development Cooperation (NORAD) in
cooperation with Roads Department Training School (RDTS)**

**Consultant:
(Intech Beusch & Co.)**

**Technical assistance and editing:
Tomas Stenström (ILO/ASIST) Harare**

Cover illustration: Dan Amayo

2004

ACKNOWLEDGEMENT

This handbook has been prepared by Roads Department Training School (RDTS), Ministry of Works and Supply in collaboration with Intech Beusch & Co., Consulting Engineers and the International Labour Organisation (ILO/ASIST). The idea behind this handbook was hatched by Messrs. Carl-Eric Hedström and Sturla Elvsveen of RDTS. The concept is based the Swedish handbook BYGG.

The management team of Roads Department Training School would like to express their gratitude to the consultant Mr. Andreas Beusch and Mr. Tomas Stenström (ILO/ASIST) whose contributions to the development of this handbook have been invaluable.

THIS HANDBOOK

This handbook is aimed primarily at small-scale contractors and covers all relevant and important aspects of labour-based road works in Zambia. However, certain modules might also be useful for any contractor working in other fields of construction than roads.

The handbook provides practical tables, guidelines and recommendations in a concentrated format for use on site. It is written in an easy understandable language so that it may be also useful to site supervisors. The handbook, however, is not a training manual and has been prepared with the assumption that users have previously attended adequate training in road works.

The handbook is the property of the Roads Department Training School, Ministry of Works and Supply, P.O. Box 34596, Lusaka, Zambia. All correspondence concerning the contents of this handbook should be directed to this address.

TABLE OF CONTENTS

Module A:	A.	CONSTRUCTION MEASUREMENTS AND CALCULATIONS	A-1
	A.1	Introduction	A-1
	A.2	Lengths	A-1
	A.3	Areas	A-1
	A.4	Volumes	A-2
	A.5	Weight and Capacity	A-3
	A.6	Density	A-4
	A.7	Slopes (as ratio and percentage)	A-4
	A.8	Pressure	A-5
	A.9	Practical Calculation Example for Volumes	A-6
	A.10	Unit Conversions	A-8
Module B:	B.	SOILS	B-1
	B.1	Introduction	B-1
	B.2	Soil Terminology and Definitions	B-1
	B.3	Soil Characteristics	B-2
	B.4	Summary Soil Classification	B-2
	B.5	Identification of Soils	B-2
	B.6	Characteristics of Soils for Road Work	B-6
	B.7	Some Common Soil Types in Zambia	B-6
Module C:	C.	SITE CAMP AND TOOLS	C-1
	C.1	Introduction	C-1
	C.2	Site Camp	C-1
	C.3	Hand Tools	C-2
Module D:	D.	SETTING OUT	D-1
	D.1	Introduction	D-1
	D.2	Measuring Aids and Instruments	D-1
	D.3	Setting out a Straight line	D-4
	D.4	Setting out Angles	D-4
	D.5	Setting out Horizontal Curves	D-5
	D.6	Setting our Gradients and Levels	D-7
Module E:	E.	LABOUR-BASED ROAD CONSTRUCTION	E-1
	E.1	Introduction	E-1
	E.2	Common Terms	E-1
	E.3	Standard Cross-Sections for Rural Roads	E-5
	E.4	Work Management	E-12
	E.4.1	Site Inspection	E-12
	E.4.2	Site Work Planning	E-13
	E.4.3	Site Camp Establishment	E-16
	E.4.4	Site Organisation and Staffing	E-18
	E.4.5	Recruitment of Labour	E-18
	E.5	Site Planning, Reporting and Monitoring	E-18

E.6	Earth Road Works (Activity Sheets)	E-19
E.7	Quality Control for Earth Road Works	E-38
E.8	Culverts	E-38
E.8.1	Definitions	E-38
E.8.2	Manufacturing Culverts	E-39
E.8.3	Setting Out	E-40
E.8.4	Bedding and Haunching	E-44
E.9	Small Structure Works	E-46
E.9.1	Introduction	E-46
E.9.2	Common Structures for Rural Roads	E-46
E.9.3	Important Considerations for the Construction of Structures	E-48
E.9.4	Gabion Works	E-49

E.10 Gravelling E-51

E.10.1	Planning and Organising Works	E-51
E.10.2	Equipment and Tools	E-52
E.10.3	Gravelling Activities (Activity Sheets)	E-53
E.10.4	Quality Control for Gravelling	E-61

Module F:	F.	COMPACTION	F-1
	F.1	Introduction	F-1
	F.2	Factors Influencing Compaction	F-1
	F.3	Compaction Plant	F-2
	F.4	Field Density Tests	F-4

Module G:	G.	CONCRETE TECHNOLOGY	G-1
	G.1	Introduction	G-1
	G.2	Materials for Concrete	G-1
	G.2.1	Aggregates	G-1
	G.2.2	Cement	G-1
	G.2.3	Water	G-2
	G.3	Types of Concrete	G-2
	G.4	Mixing of Concrete	G-3
	G.4.1	Batching	G-3
	G.4.2	Mixing	G-3
	G.4.3	Water Cement Ratio	G-4
	G.5	Transporting Concrete	G-5
	G.6	Placing Concrete	G-5
	G.7	Construction Joints	G-6
	G.7.1	Definition and Purpose	G-6
	G.7.2	Construction Joint Between Foundation and Wall	G-6
	G.7.3	Joints for Retaining Walls	G-7
	G.7.4	Joints for Floor Slabs	G-8
	G.8	Curing Concrete	G-8
	G.9	Removal of Formwork	G-8
	G.10	Quality Control for Concrete Works	G-9

Module H:	H.	STONE MASONRY WORK	H-1
	H.1	Introduction	H-1
	H.2	Materials for Stone Masonry (cement bound)	H-1
	H.3	Mortar	H-1

	H.4	Quantities	H-2
	H.5	Stone Masonry Work	H-3
	H.5.1	Foundations	H-3
	H.5.2	Construction of Walls	H-3
	H.6	Dry Stone Masonry (without mortar)	H-4
	H.7	Brick and Block Masonry Work	H-5
	H.8	Quality Control for Mortar	H-7
Module I:	I.	CULVERT PRODUCTION	I-1
	I.1	Introduction	I-1
	I.2	Manufacturing Facilities and Resources	I-1
	I.3	Casting	I-1
	I.4	Stripping and Curing	I-2
	I.5	Loading, Transport and Off-Loading	I-2
Module J:	J.	TRAFFIC CONTROL AND SAFETY	J-1
	J.1	General	J-1
	J.2	Standard Signs	J-1
	J.3	Traffic Control	J-2
Module K:	K.	ROAD MAINTENANCE	K-1
	K.1	Introduction	K-1
	K.2	Common Maintenance Terms	K-1
	K.3	Maintenance Operations and Activities	K-5
	K.4	Management for Routine Maintenance Work	K-7
	K.4.1	Management Cycle	K-7
	K.4.2	Organising Routine Maintenance Works	K-7
	K.5	Routine Maintenance Activities for Drainage of Paved and Unpaved Roads, Carriageway of Unpaved Roads	K-10
	K.6	Routine Maintenance For Carriageway of Paved Roads	K-24
Module L:	L.	MAINTENANCE OF PLANT AND VEHICLES	L-1
	L.1	Introduction	L-1
	L.2	Workshop Set-up	L-1
	L.3	Control System	L-3
	L.4	Maintenance of Plant	L-5
Module M:	M.	PRODUCTIVITY GUIDELINES	M-1
	M.1	General	M-1
	M.2	Productivity Rates for Earth Road Works	M-1

	M.3	Productivity Rates for Graveling Works	M-3
	M.4	Productivity Rates for Hauling Equipment	M-5
	M.5	Productivity Rates for Routine Maintenance Works	M-6
Module N:	N.	WORK PROGRAMMING AND REPORTING	N-1
	N.1	Introduction	N-1
	N.2	Required Plans and Reports	N-1
	N.3	Planning Process	N-2
	N.4	Useful Planning Checklists	N-3
Module O:	O.	CONTRACT PROCEDURES	O-1
	O.1	General	O-1
	O.2	Contracting Parties	O-2
	O.3	Contract Documents	O-2
	O.4	Tender Procedures	O-3
	O.5	Contract Implementation	O-5
	O.5.1	Mobilisation	O-5
	O.5.2	Contract Supervision	O-8
	O.5.3	Contract Administration	O-10
	O.5.4	Dispute Procedure	O-12
	O.6	Demobilisation	O-13
	O.7	Maintenance Period	O-15
	O.8	Post Construction Evaluation	O-17
	O.8.1	Records	O-17
	O.8.2	Productivity and Cost Control	O-17
Module P:	P.	LABOUR RECRUITMENT AND ISSUES, SAFETY AND HEALTH ON SITE	P-1
	P.1	LABOUR LAWS AND REGULATIONS	P-1
	P.1.1	Introduction	P-1
	P.1.2	General Labour Regulations	P-1
	P.2	LABOUR RECRUITMENT AND REMUNERATION	P-3
	P.3	SAFETY AND HELATH ON SITE	P-6
	P.4	HIV AND AIDS	P-6

REFERENCE MATERIAL

INDEX

MODULE A:

CONSTRUCTION MEASUREMENTS AND CALCULATIONS

A.1	Introduction	A-1
A.2	Lengths	A-1
A.3	Areas	A-1
A.4	Volumes	A-2
A.5	Weight and Capacity	A-3
A.6	Density	A-4
A.7	Slopes (as ratio and percentage)	A-4
A.8	Pressure	A-5
A.9	Practical Calculation Example for Volumes	A-6
A.10	Unit Conversions	A-8

A.1 INTRODUCTION:

In road works technical personnel are often confronted with situations where a basic knowledge of mathematics becomes necessary. These include: setting out of vertical and horizontal alignments, detailed setting out of work tasks, calculation of earth volumes, calculation of areas e.g. for clearing, calculation of equipment performance rates, estimation of performance rates for labour, calculation of masonry and concrete work, and many more. World wide the metric system is the universal system of measurements (System International = **SI**) with standard units for length, weight, time, temperature, etc. A conversion table with the most common units is provided at the end of this module.

Do not mix the measurement systems and units. Before you make any calculations you have to make sure that you use one system and one unit only.

A.2 LENGTHS

Definition = the standard unit for length is the **metre** (m). For shorter lengths **centimetre** (1m = 100cm) is used which is again subdivided into **millimetres** (1cm = 10mm). for longer distances however, **kilometre** (1000m = 1km) is used.

Conversion:

	mm	cm	m	km
1mm	1	0.1	0.001	0.000001
1cm	10	1	0.01	0.00001
1m	1,000	100	1	0.001
1km	1,000,000	10,000	1,000	1

Length; for construction work the most common and practical units are metres and centimetres.

A.3 AREAS

Definition = 1m² is the area of a square having sides whose length is 1m. Consequently every unit of length can be converted into an area if it is multiplied by itself.

Therefore:

mm x mm = mm²	cm x cm = cm²	m x m = m²	km x km = km²
---------------------------------	---------------------------------	------------------------------	---------------------------------

Other special units are:

10m x 10m = 100m² = 1are	100m x 100m = 10,000m² = 1hectare
--	---



It is always advisable when working out areas to make sure that all the units are the same.

Relationship between the various units or areas:

	mm ²	cm ²	m ²	hectare	km ²
1mm²	1	0.01	0.0000001		
1cm²	100	1	0.0001		
1m²	1,000,000	10,000	1	0.0001	0.000001
hectare			10,000	1	0.10
1km²			1,000,000	100	1

Note: to convert the area to one unit higher multiply it by 100 and from a higher to a lower unit divide it by 100 as shown above.

Calculations for areas:

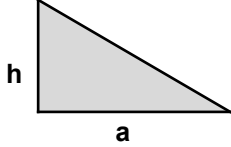
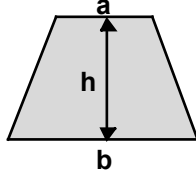
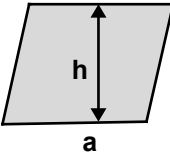
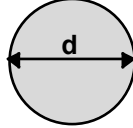
 <p style="text-align: center;">square: $a \times a$</p>	 <p style="text-align: center;">rectangle: $a \times b$</p>
 <p style="text-align: center;">triangle: $\frac{a \times h}{2}$</p>	 <p style="text-align: center;">trapezoid: $\frac{a + b}{2} \times h$</p>
 <p style="text-align: center;">rhombus: $a \times h$</p>	 <p style="text-align: center;">circle: area = $\frac{d^2 \times \pi}{4}$ circumference = $d \times \pi$</p>

Note: a practical example of area, volume and slope calculation is shown at the end of this module

A.4 VOLUMES

Definition = 1m^3 is the volume of a cube where each side is 1m. Volumes are calculated by multiplying a base area (e.g. m^2) with a third dimension.

Therefore:

$\text{mm}^2 \times \text{mm} = \text{mm}^3$	$\text{cm}^2 \times \text{cm} = \text{cm}^3$	$\text{m}^2 \times \text{m} = \text{m}^3$	$\text{km}^2 \times \text{km} = \text{km}^3$
--	--	---	--

➔ The most important units for road works are = cm^3 and m^3

Relationship between the various units of volume:

	cm^3	dm^3 1 litre	m^3
1cm^3	1	0.001	0.000001
1dm^3	1000	1	0.001
1m^3	1,000,000	1,000	1

➔ To change a volume from one unit to the next lower or higher one, multiply or divide the quantity by 1000 respectively.

Calculations for volumes:

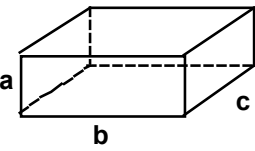
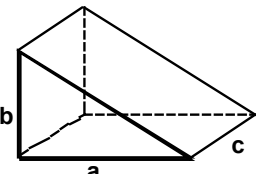
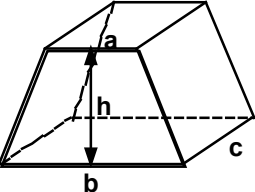
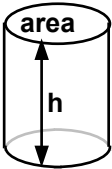
 <p>rectangular prism: $a \times b \times c = v$</p>	 <p>triangular prism: $\frac{a \times b}{2} \times c = v$</p>
 <p>quadrilateral prism: $\frac{a + b}{2} \times h \times c = v$</p>	 <p>cylinder: $\text{area} \times h$ $\frac{d^2 \times \pi}{4} \times h = v$</p>

A.5 WEIGHT AND CAPACITY

Weight:

Definition = 1 kilogram (kg) is the weight of one cubic decimetre (dm³) or one litre of water with a temperature of 4° C. Other units commonly used in construction are: gram (g) and tonne (t).

Relationship between the various units of volume:

	gram	kilogram	tonne
1g	1	0.001	0.000001
1kg	1,000	1	0.001
1t	1,000,000	1000	1



The most important units for road works are kilogram and tonne

Capacity:

Definition = 1 litre of water is the volume of water contained in one cubic decimetre (dm³) at 4°C.

Therefore:

$1\text{dm}^3 = 1 \text{ litre}$	$1\text{m}^3 = 1000 \text{ litre}$	$1 \text{ litre} = 0.001\text{m}^3$
----------------------------------	------------------------------------	-------------------------------------

Relationship between volume, capacity and weight (of water):

$1\text{dm}^3 = 1 \text{ litre} = 1\text{kg}$	$1\text{m}^3 = 1000 \text{ litre} = 1\text{tonne}$	$1 \text{ litre} = 0.001\text{m}^3 = 0.001\text{tonne}$
---	--	---

A6 DENSITY

Definition = weight in kg per m³ volume in normal processed condition of the material.

	kg/m³		kg/m³
Steel and Iron	7800	Stone for masonry work (dense)	2500-3000
Aluminium	2700	Stone for masonry work (porous)	2200-2500
Copper	8900	Building Sand (natural moisture)	1900-2100
Lead	11,3400	Building Sand (dry)	1800-2000
Wood	400 - 800	Gravel (clean, without fines)	1500-1800
Hardwood	700-1000	Cohesive Soil	1800-2000
		Heavy Clay	1800-2000
Asphalt	1600-2000	Cement or Lime Mortar	1900-2100
Bitumen	1100	Cement (loose)	1200-1400
		Lime (loose)	900-1300
Cement Stone Wall (with mortar)	1800-2000	Concrete with reinforcement	2300-2500
Lime Stone Wall (with mortar)	1600-2000		
Brick Wall (with mortar)	1300-1500	<i>Water</i>	<i>1000</i>
Masonry wall (with mortar)	2000-2200		

A.7 SLOPES (as ratio and percentage)

Definition = the slope shows the steepness of an ascent or descent.

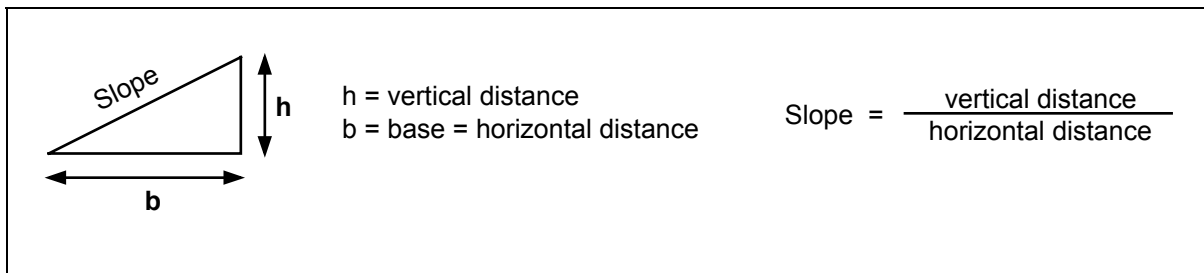

Slope calculation = slopes can be expressed as a ratio or in percentage.

Slope given as a **ratio**:

Examples

$$\text{Slope} = \frac{\text{vertical distance}}{\text{horizontal distance}} = \frac{2}{4} = \frac{1}{2} = 1 : 2$$

$$\text{Slope} = \frac{\text{vertical distance}}{\text{horizontal distance}} = \frac{1}{3} = 1 : 3$$

Note:

- The figure on top should always be the vertical distance and the figure below should always be the horizontal distance.

Slope given in **percentage (%)**:

Any fraction (ratio) can be expressed in % by dividing the result by 100%.

Examples

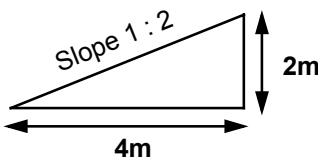

$$\text{Slope} = \frac{\text{vertical distance}}{\text{horizontal distance}} \times 100\% = \frac{2}{4} \times 100\% = 50\%$$

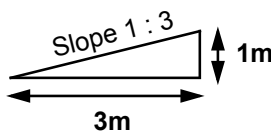

$$\text{Slope} = \frac{\text{vertical distance}}{\text{horizontal distance}} \times 100\% = \frac{1}{3} \times 100\% = 33.33\%\dots$$

Formulas:

slope = height / base

height = base x slope

base = height / slope

A.8 PRESSURE

Pressure is defined as the distributed force (F) acting on an area (A). The standard unit for pressure is Pasqual (Pa)

Pressure:

$$P = \frac{\text{Force}}{\text{Area}} \quad \frac{F}{A}$$

F is measured in Newton (N)

A is usually measured in m² or in cm²

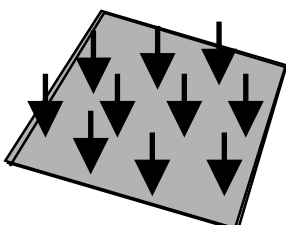

However, force measured in Newton is not a value we easily recognise in daily life. To simplify, when dealing with water, we could utilise the fact that one litre (or 1000 cm³) of water weighs 1kg. Hence a 10 metre water column produces a force of 1kg per every cm², and for every 10 metres the force increases with 1kg.

Weight of Water:

1m³ water weight = 1000 kg

1dm³ water weight = 1 kg

1 cm³ water weight = 1 gram

Calculation Example:

$P_a = D/10$ (D is the height of the water column)

At 60m vertical height the pressure in a water pile is

$$\frac{D}{10} = \frac{60}{10} = 6\text{Kg/cm}^2$$

Conversions for Pressure:

1 bar = 100 000 Pa

A.9 PRACTICAL CALCULATION EXAMPLE FOR VOLUMES

The calculation of volumes is the most common calculation for road construction work. This is required to develop the bill of quantities, then to measure work for actual construction purposes (estimating resource requirements and time to complete work, material requirements, etc.), and finally to measure the completed work items.

The example on the next page shows the detailed calculations while the table below explains the principle process:

Calculation of volume of excavation for side ditches

Calculate the volume of excavation required for the ditches including the slopes on both sides of the road after levelling of the sub-grade has been completed, over a road length of 100m:

1. divide the ditch-slope area into areas, which can be easily calculated
2. calculate the area of each part and multiply by two (for both sides)
3. calculate the total sum of all areas
4. to get the volume, multiply the total area with the length of the road

Calculation of volume of fill for formation

Calculate the volume of fill required for the formation over a road length of 100m:

1. divide the formation areas into areas, which can be easily calculated
2. calculate the area of all parts
3. calculate the total sum of all areas
4. to get the volume, multiply the total area with the length of the road

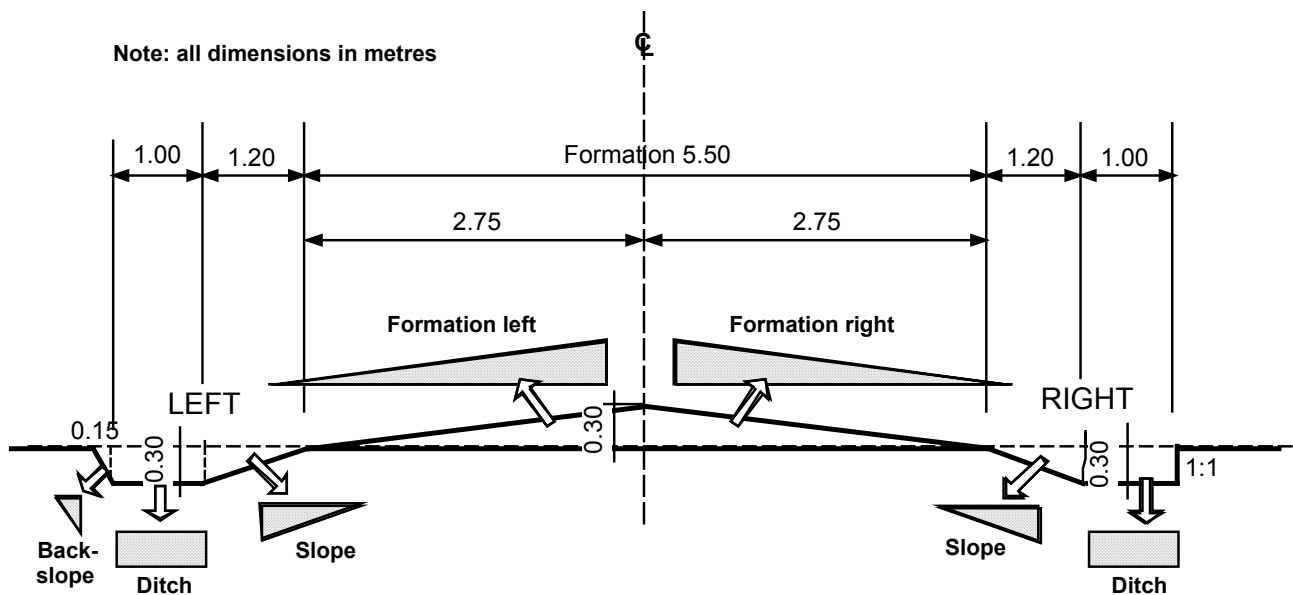

DITCH AREA BOTH SIDES	Part Area of Ditch	Formula	Calculation
	Slope left and right 	$\frac{a \times b}{2} \times 2$	$\frac{0.3m \times 1.2m}{2} \times 2 = 0.36m^2$
	Ditch left and right 	$a \times b \times 2$	$0.3m \times 1.0m \times 2 = 0.6m^2$
	Backslope left 	$\frac{h \times b}{2}$	$\frac{0.3m \times 0.15m}{2} = 0.0225m^2$
	Total Area of Ditch, Both Sides		$0.36m^2 + 0.6m^2 + 0.0225m^2 = 0.9825m^2$

Ditch Volume Both Sides for 100m Road	Total Area (m²) x 100m	$0.9825m^2 \times 100m = 98.25m^3$
--	--	------------------------------------

FORMATION	Area of Formation	Formula	Calculation
	Formation left 	$\frac{a \times b}{2}$	$\frac{2.75m \times 0.30m}{2} = 0.4125m^2$
	Formation right 	$\frac{a \times b}{2}$	$\frac{2.75m \times 0.30m}{2} = 0.4125m^2$
Total Area of Formation		$0.4125m^2 + 0.4125m^2 = 0.825m^2$	

Formation for 100m of Road	Total Area (m²) x 100m	$0.825m^2 \times 100m = 82.5m^3$
-----------------------------------	--	----------------------------------

A.10 UNIT CONVERSIONS

Jnit System	Metric		Imperial + US			
Length	Metre (m)	Kilometre (km)	Inch (in)	Foot (ft)	Yard	Mile
	1	0.001	39.3701	3.28084	1.09361	0.00062
	1000	1	39370.1	3280.84	1093.61	0.62137
	0.0254	0.00003	1	0.08333	0.02778	0.00002
	0.3048	0.00030	12	1	0.33333	0.00019
	0.9144	0.00091	36	3	1	0.00057
	1609.34	1.60934	63360	5280	1760	1
Jnit Syst	Metric			Imperial + US		
Area	Square Metre (m2)	Are (a)	Hectare (h)	Square Kilometre (km2)	Square Yard	Acre
	1	0.01	0.0001	0.000001	1.19599	0.00025
	100	1	0.01	0.0001	119.599	0.02471
	10,000	100	1	0.01	11,960	2.47105
	1,000,000	10,000	100	1	1,196,000	247.105
	0.83613	0.00836	0.00004		1	0.00021
	4046.86	40.4686	0.40469	0.00405	4840	1
Jnit System	Metric		Imperial + US			
Volume	Cubic Metre (m3)	Litre (lt.)	U.S. Gallon	Cubic Inch	Cubic Feet	Imperial Gallon
	1	1,000	264.171	6,1023.7	35.3147	219.978
	0.001	1	0.26418	61.0255	0.03532	0.21998
	0.00379	3.78532	1	231.001	0.13368	0.83270
	0.00002	0.01639	0.00433	1	0.00058	0.00360
	0.02832	28.316	7.48048	1728	1	6.22883
	0.00455	4.54596	1.20095	277.42	0.16054	1
Jnit System	Metric			Imperial + US		
Weight	Gram (g)	Kilogram (kg)	Ton (t)	Carat	Ounce (oz)	Pound (lb)
	1	0.001		5	0.03527	0.00220
	1,000	1	0.001	5000	35.274	2.20462
	1,000,000	1,000	1	5,000,000	35274	2204.62
	0.2	0.0002		1	0.00705	0.00044
	28.3495	0.02835	0.00003	141.748	1	0.06250

MODULE B:

SOILS

B.1	Introduction	B-1
B.2	Soil Terminology and Definitions	B-1
B.3	Soil Characteristics	B-2
B.4	Summary Soil Classification	B-2
B.5	Identification of Soils	B-2
B.6	Characteristics of Soils for Road Work	B-6
B.7	Some Common Soil Types in Zambia	B-6

B.1 INTRODUCTION

The soil forms the primary building material especially on road projects. It is therefore important for contractors to know how to recognise which soils are suitable for road works and which are not. Contract specifications often describe the required quality of soils, which contractors must be capable of interpreting in specialist terminology. Often simple field tests are necessary to make the required choice of suitable material.

B.2 SOIL TERMINOLOGY AND DEFINITIONS

ACCORDING TO PARTICLE (GRAIN) SIZE; The nature of the soil depends largely on the sizes of particles forming the solid part of the soil and are the basis for the identification of different soils.	
Gravel	Consists of 2 - 60 mm stones (the term gravel is also used in road terminology for a mixture of stones, sand and clay for surface layers)
Sand	Grains of size 0.06 - 2 mm , coarse to fine gritty soil, firm when damp
Silt	Fine grain soil of size 0.002 - 0.06 mm , non-plastic. When dry = fine soft powdery silt and does not stain hands when wet
Clay	Very fine soil of the size 0 - 0.002 mm , plastic. When dry = hard lumps with cracked surface and stains hands when wet
Organic Soil	The soil contains remnants of plants, roots , etc. and has a distinct smell, dark in colour

the particle sizes, silt, clay, sand and gravel.

Coarse grain soils	The soil consists mainly of sand and gravel, with little or no silt or clay
Fine grain soils	Mainly silt and clay
Cohesive	The soil sticks together, mainly clay
Non cohesive	The soil does not stick together, mainly sand and gravel
Well graded	A wide range of particle sizes which are well distributed (note: a mixture of particle sizes means that the soil will be easier to compact)
Poorly graded	Not all particle sizes are present in the soil; too much of some sizes and too little of others
Uniformly graded	Soil with a limited range of sizes, mainly concentrated in one size category
Proportions of soil fractions	E.g. 10% gravel, 20% sand, 50% silt and 20% clay

Plasticity	The degree to which the soil can be moulded (clay is very plastic)
Moulding	Forming soils in certain shapes (e.g. threads)
Stability	A stable soil, is not easily deformed
Bearing Capacity	The ability (strength) of the soil to carry surface loads (measured by the weight that can be loaded on to a specified area without penetration - or the amount of penetration under a certain load on a specified area).
Density	In a dense soil the particles are close together (or well compacted)
Optimum moisture cont.	The water content gives the best effect of soil compaction
Compaction	The process which packs the particles close together (by pressure, tamping or vibration) and consequently increasing the density and bearing capacity
Permeability	The degree to which water can penetrate a particular soil

B.3 SOIL CHARACTERISTICS

The behaviour of soils depends upon two basic factors:

1. Composition, proportion of soil fractions
2. Condition of the soil, water and air content

Fine Grain Soil	Silt and clay are strongly affected by the amount of water present (moisture content). With increasing moisture content the silt and clay will: - first become plastic = can be moulded - then become liquid = begins to flow like water
Coarse Grain Soil	Sand and gravel are affected to some extent by an increased moisture content, but not extensively
Combination Soils	Soils by nature are a combination of coarse and fine grain soils. Both the moisture content and the particle distribution affect their behaviour.

B.4 SUMMARY SOIL CLASSIFICATION

Division	Types	Grain Size (mm)		Sub-groups	Characteristics
		Min.	Max		
	Stones	60	-	-	-
coarse grained soils, non-cohesive	Gravel	2	60	Gravel with few fines	The amount of fines does not exceed 12% of the total weight. Gravel can be well graded or poorly graded
				Gravel with many fines	The amount of fines exceeds 12% of the total weight
	Sand	0.06	2	Sand with few fines	The amount of fines does not exceed 12% of the total weight. Sand can be well graded or poorly graded
				Sand with many fines	The amount of fines exceeds 12% of the total weight.
fine grained soils, cohesive	Silt	0.002	0.06	-	Gritty to touch, slight cohesion
	Clay	-	0.002	-	Smooth and greasy to touch, high cohesion
organic soils	-	-	-	-	Usually contains remnants of plants, roots, etc. and has a distinct smell, dark in colour

B.5 IDENTIFICATION OF SOILS

By means of visual inspection and simple field tests it is possible to roughly identify any type of soil and classify it in one of the subgroups as described in section B.4. (Laboratory tests are necessary if a detailed soil classification is required.)

Procedure:

The field classification is shown in the chart on the following page. It consists of a process of elimination. Each test (indicated with hexagons) must be carried out until the soil can be classified in the proper group. The rectangles give the names of the division, the type and finally the group to which the soil belongs.

Note:

Do not attempt to identify a soil on the basis of one test only. Simply obtain a general impression from a series of tests, remembering that many natural soils are a mixture of different fractions, e.g. gravely sands, silty clays, etc.

PROCEDURE FOR SIMPLE FIELD IDENTIFICATION OF SOILS

Note:
The number indicated in brackets refer to the tests described below.

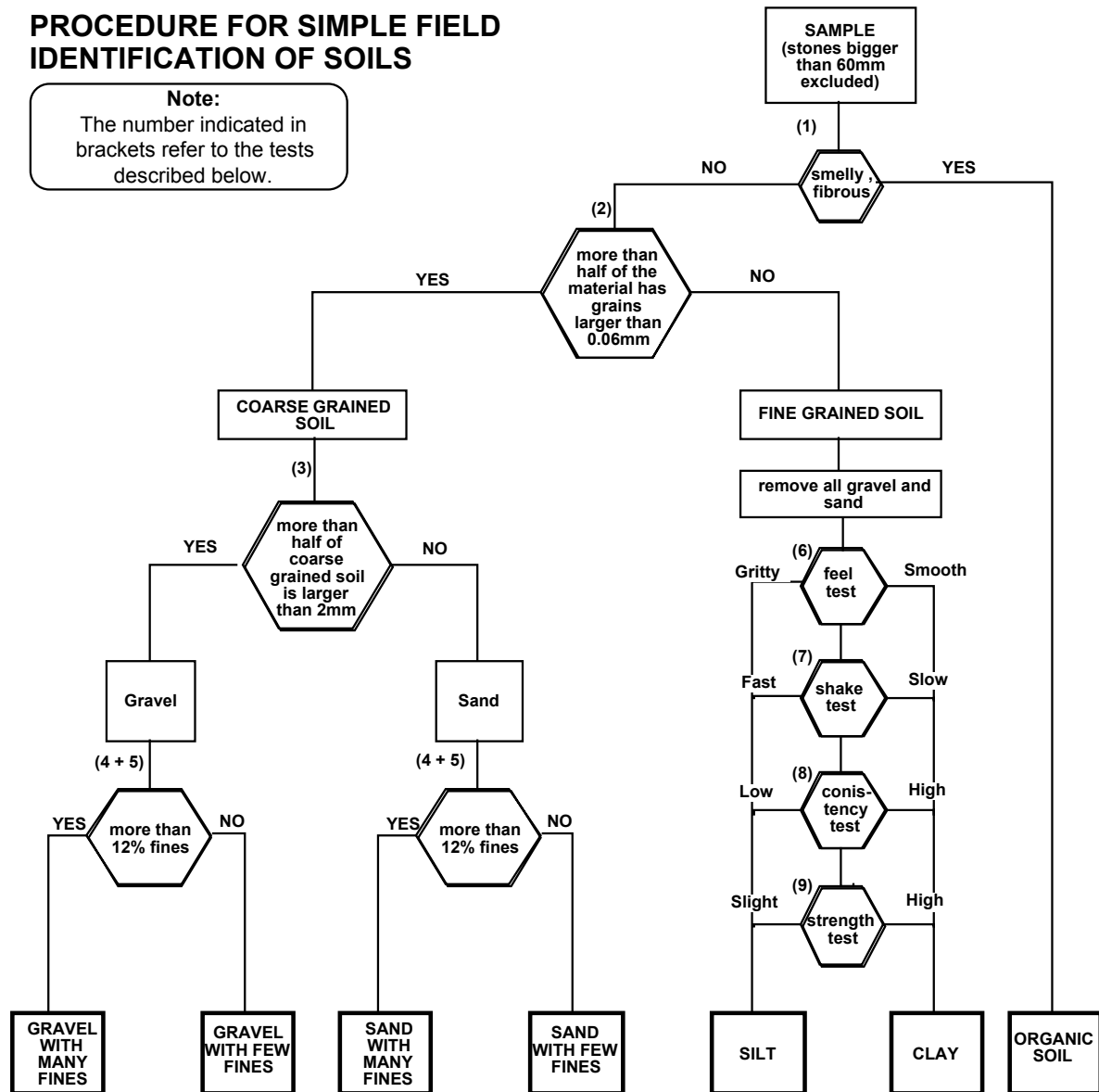

Suitability for road works:
Gravel with Many Fines = FAIR / Gravel with Few Fines = Good / Sand with Many Fines = FAIR / Sand with Few Fines = POOR

Unsuitable for road works:
Silt, clay and organic soil

*Field Tests:***TEST 1: Organic Particles**

Take the sample of the soil and smell it. If it has an earthy or vegetable smell it is probably organic. Organic soils are also easily identifiable by sight and feeling; they are often fibrous, spongy and usually brown or black in colour.

TEST 2: Visual Test to determine coarse or fine grain soil

Spread the dry sample on a flat surface or in the palm of your hand to classify as coarse grained or fine grained soil. Size of grains larger than 0.06mm can be distinguished by sight, whereas fines below 0.06mm cannot. If more than half of the material has grains larger than 0.06 then the soil can be classified as coarse grained. In case you have doubts then the sedimentation test (4) can also be helpful. Depending on the bigger fraction (over 50%), the soil is classified as coarse grained silt (gravel or sand) or fine grained soil (silt or clay).

A. Tests for Coarse Grained Soils:**TEST 3: Visual Test for Coarse Grained Soil**

If the sample has been classified under coarse-grained soil, estimate the proportions of grains smaller and larger than 2.0mm (the size of a pinhead equals about 2.0mm) and classify the soil under sand or gravel, depending on what proportion is the largest (over 50%).

TEST 4: Sedimentation Test for Coarse Grained Soil

Place the sample, excluding the stones, in a clean glass jar with straight sides. Pour in some water, shake well and allow the soil to settle. The coarser particles soon settle at the bottom and the proportions of finer material can then be gauged from the thickness of the succeeding layers. Measure the thickness of the individual layers and calculate the percentage of them in relation to the total height of the entire sample in the jar. If the fines are more than 12% of the total sample, then the sample is either gravel or sand with many fines. If the fines are less than 12% then the sample has few fines.

(Setting will be clearer if a pinch of table salt is added to the water.)

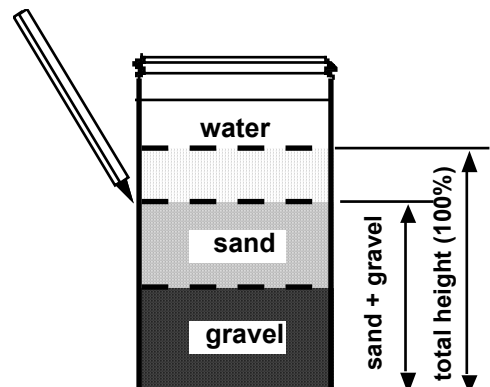
**TEST 5: Cohesion Test for Coarse Grained Soil**

To assess the presence of fines, the following quick procedure can also be useful:

- with gravel, the material will not stick together unless there are fine materials present
- with sand, the damp sample sticks together but will crumble at a touch if no fines are present

B. Tests for Fine Grained Soils:

The distinction between silt and clay is not as clear as between gravel and sand. That is the reason why all the four tests below must be carried out to classify the fine-grained soils.

Note: Before carrying out the test for fine-grained soils, all the grains larger than 0.5mm must be removed (best with a sieve).

TEST 6: Feeling Test for Fine Grained Soil

When dry = - silt is readily powdered
- clay cannot be powdered and is in hard lumps

When wet = - silt is a gritty-floury soft material
- clay becomes plastic and sticky

TEST 7: Shaking Test for Fine Grained Soil

Prepare a pat of moist soil with a volume of about 8cm³. If necessary add enough water to the soil to make it soft but not sticky. Place the pat in the open palm of one hand and shake horizontally, striking vigorously against the other hand several times:

- If it is silt, water appears on the surface of the pat and it becomes glossy and when the sample is squeezed between the fingers the water and gloss disappear from the surface.
- If it is clay, then there is no reaction.

TEST 8: Moulding Test for Fine Grained Soil

A soft lump of the cohesive soil (about 8cm³) is moulded to the consistency of putty. The specimen is rolled out on a table into threads of about 3mm in diameter.

- If it is silt, it will not be possible to form proper threads and will crumble into small pieces
- If it is clay, it will be possible to mould proper threads

TEST 9: Dry Strength Test for Fine Grained Soil

Mould a pat of soil to the consistency of putty, adding water if necessary. Allow the pat to dry completely in the sun and test its strength by breaking and crumbling between the fingers.

- High dry strength is characteristic of clays
- Silt has only very slight strength and crumbles easily

B.6 CHARACTERISTICS OF SOILS FOR ROAD WORK

Soil Types	Grading	Compressibility when Compacted	Bearing Capacity	Resistance to Wear And Tear	Suitability as Road Material
Gravel with few fines	well graded	almost none	excellent	good	
	poorly graded	almost none	fair to good	fair	good
Gravel with many fines	well and poorly graded	slight	fair to excellent	fair to good	fair
Sand with few fines	well graded	almost none	poor to fair	good	fair
	poorly graded	almost none	poor	poor	poor to fair
Sand with many fines	well and poorly graded	slight to medium	poor to fair	fair to good	poor to not suitable
Silt	-	medium	very poor	very poor	not suitable
Clay	-	high	very poor	poor	not suitable
Organic	-	very high	very poor	very poor	not suitable

The ideal composition (grading) of gravel material is usually determined by the given standards of the client and is often also described in detail in the contract specifications. In the absence of norms a rule of the thumb may be applied:

- 
- ◆ **Fines** = 10% Clay and Silt (smaller than 0.06mm)
 - ◆ **Medium** = 40% Sand (0.06 – 2.0mm)
 - ◆ **Coarse** = 50% Stones (bigger than 2.0 – 37.5mm)

B.7 SOME COMMON SOIL TYPES IN ZAMBIA

Red Coffee: a soil which on simple analysis would appear to be a clay but tends to behave more like a sandy clay. Often the clay is washed out of the upper part of the soil and deposited in lower layers. Although this soil is not very suitable for road construction it is often used as a sub-base and base material due to the lack of better local material.

Laterite: a red yellow soil which is a clayey gravel, often fairly uniformly graded. According to the amount of iron that has accumulated, the hardness of the gravel can vary considerably. This type of soil, if properly compacted, is quite stable in fair weather but will dust up in the dry season and becomes slippery and sticky with heavy rains.

Black Cotton: a dark coloured (black or dark grey) expansive clay. When the moisture content changes, the soil shrinks or swells. This makes the soil extremely weak and is therefore not suitable for road construction.

Sandy Soil: common in the Western Province. If sand has still some clay content it may be used for road works. However, the strength of sand is limited and good compaction at optimum moisture content is essential to achieve the required density. Sand without binder should be avoided for road works unless it can be stabilised using bitumen (cement is usually not suitable for sand because of the single-sized particle size distribution).

MODULE C:

SITE

C.1	Introduction	C-1
C.2	Site Camp	C-1
C.3	Hand Tools	C-2

C.1 INTRODUCTION

This module describes the site camp arrangements and tools, which are required for labour-based road construction sites. The size of a camp and the number of tools depend basically on the number of workers employed. The details mentioned in this module assume an average of 100 workers on an earth construction site and 120 workers on a gravelling site.

C.2 SITE CAMP

Location:

- To be within walking distance of all works. The distance from the camp to the furthest working place should not exceed 4km. For roads longer than 8km, the camp needs to be shifted.
- To be situated on a well-drained location and if possible not in a depression.
- To be close to a water source.
- To be large enough to contain stores, site office and if necessary staff accommodation including latrines.
- Camps for major structural works (drifts, bridges) should be next to the site to avoid hauling construction materials.
- Preferably to be located away from villages and markets centres but not so far as to cause unnecessary problems with the purchase of food, etc.
- To be accessible to project vehicles.

Infrastructure:

The size of the camp depends on the kind of work to be undertaken and on how many people need to be housed on site. Movable field huts provide the best comfort and security. On average the following huts are required:

- 1 hut for the site supervisor for accommodation,
- huts for the plant operators (mainly for the gravelling activities),
- 1 hut as site office,
- 1 site store for tools, small equipment, spare parts and cement,
- 1 site store for fuel, oil and lubricants,
- latrine(s) and bathroom hut.
- fence around the camp for security.

For security reasons, fencing might be required around the site camp. The stores should be equipped with a proper stock control system (cards for all items or a small booklet are sufficient), which will assist in controlling the movements of tools, equipment and goods.

Timing:

The camp installation is usually the first site activity. It is advisable to have the camp fully established before actual work on the road site starts.

Staff:

- Apart from the site supervisor it is useful to have a trustworthy storekeeper to keep track of materials and tools (maintaining records) and to carry out minor repairs to tools (changing of handles, sharpening of tools, etc.).
- Depending on the local security situation, it might be necessary to engage watchmen who should guard the camp around the clock.
- If the camp is not close to water, carriers must be employed.
- It is advisable to separate staff huts from stores and site office.
- A well-stocked first aid kit must be on site and accessible to the staff.
- Protective gear, such as goggles, helmets, dust masks, gloves, etc. should also be made available to labourers who carry out work where protection is required.

C.3 HAND TOOLS

The number and types of tools and equipment depends on the task and the number of workers employed. Proposed standard lists of tools and equipment are presented on the next pages. These lists can be used as a guide but need to be adjusted for a specific project.

Standard list of site tools and equipment for <u>Earth Construction</u> ; fo	
Tools	construction work
• Hoes	40
• Shovels	30 - 40
• Mattocks	20 - 35
• Picks	20 - 35
• 16Lb Hammers	4 - 6
• 4Lb Hammers	2
• Claw Hammers	2
• Sledge Hammers	6
• Crow Bars	4 - 6
• Round Eye Axes	2
• Traditional Axes	4 - 8
• Rakes	6 - 10
• Spreaders	4 - 6
• Steel Buckets	6 - 10
• Wheel Barrows	10 - 15
• Hand files	2
• Slashers	6 - 15
• Machetes	2 - 6
• 5m Tape	1
• 30m Tape	2 - 3
• Line Level	1
• 1m Spirit Levels	2
• 60cm Spirit Levels	1 - 2
• Bow Saws	2
• Building Trowels	4 - 6
• Profiles	30
• Travellers	4
• Camber Boards	2
• Camping Tents	2
• First Aid Kit	1

Additional Tools and Equipment per Gang	Number required for earth construction work
• Hard Brooms	2
• Balls of Twine	8
• Hand Rammers	8
• Fishing Line	1 roll x 20m
• Ditch Template	2
• Bicycle	1
• Water Drums, 210 Lt.	1
• Dead Weight Roller	1
• Road Sign Posts	3

Note:

- Dead weight rollers can be tractor/manual or animal drawn. Also pedestrian vibrating equipment can be used. For details on compaction equipment see module F “Compaction”.
- In rocky terrain tools like pickaxes, sledge hammers, chisels and crowbars must be available in sufficient numbers.
- Hand rammers are mainly used to compact the back fill when installing culverts.
- Measuring aids are specifically described in module D. “Setting Out”.

Standard list of site tools and equipment for <u>Gravelling</u>; for gang of 35 workers	
Tools	Number required for gravelling
• Shovels	30
• Hoes	15
• Mattocks	10
• Bush knives	2
• Wheelbarrows	15
• Crow bars	4
• Spreaders / Rakes	10
• Tape measures (30m)	1
• Buckets	6
• Ditch Templates	2
• Camber Board	1
• Compaction equipment	1
• Watering equipment	1
• First aid kit	1
• Balls of Twine	8
• Water Drum , 210 Lt.	1
• Bicycle	1
• Fishing Line	20m
• Line Level	1
• 5m Tape	1
• Road Signs	3
• Chisels	4
• Spirit Levels	2
• Hand Files	4
• Profiles	15
• Hand Rammers	8
• Bow Saw	2
• 16Lb Hammers	4
• 4Lb Hammers	2
• Claw Hammers	1
• Sickles	2
• Slashers	10
• Hard Brooms	2

<i>Additional Tools per Gang</i>	Number required for earth construction work
• Hard Brooms	2
• Balls of Twine	8
• Fishing Line	1 roll x 20m
• Bicycle	1
• Water Drums, 210 Lt.	1
• Road Sign Posts	3

Equipment:

- ◆ For **hauling** gravel tractor and trailer combinations are ideal if the distance is less than 6km. For longer distances lorries (flat bed or tippers) are more suited.



For details on hauling equipment see module E, “Labour Based Construction”.

- ◆ For **compaction** dead weight rollers can be tractor/manual or animal drawn. Pedestrian vibrating equipment is ideal for labour-based gravelling sites. For details on compaction equipment see module F, “Compaction”.



For details on compaction equipment see module F, “Compaction”..



Measuring aids are specifically described in Module D, Setting Out.

MODULE D:

SETTING OUT

D.1	Introduction	D-1
D.2	Measuring Aids and Instruments	D-1
D.3	Setting out a Straight line	D-4
D.4	Setting out Angles	D-4
D.5	Setting out Horizontal Curves	D-5
D.6	Setting our Gradients and Levels	D-7

D.1 INTRODUCTION

The surveying and setting out requirements for labour-based road construction vary with the type of work to be executed. The construction of new roads requires a complete survey by the Engineer to establish the alignment. The engineer provides the contractor with the relevant reference points and levels. The module describes simple methods for setting out on site after the Engineer has established the alignment.

D.2 MEASURING AIDS AND INSTRUMENTS

The site work setting out should be done using the simplest instruments and methods possible.

Elementary simple measuring aids and instruments for site work setting out:

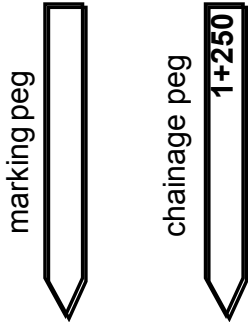
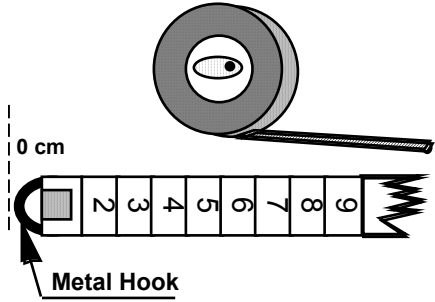
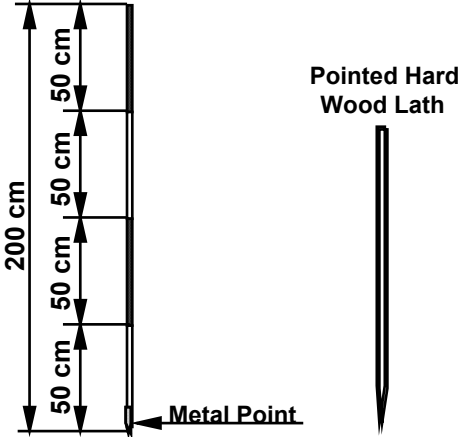
<p>Pegs: Pegs are used for survey purposes and for setting out all the activities. On labour-based sites usually wooden sticks are used of approximately 50 cm length and strings. On one end they are pointed so that they can easily be hammered into the ground. Survey pegs, for example chainage pegs, are cut at the edge so that a clear marking can be made.</p>	
<p>Tape Measure: A great variety of tape measures exist. The most common length of tape measure used for setting out is 30 metres. The tapes are made of steel or linen. Although the former is stronger, the numbers/ marking on the tape become unreadable after a period of use. Note: The location of the 'zero point' may differ from tape measure to tape measure</p>	
<p>Ranging Rods: Ranging rods are round sticks usually 2 m long with a diameter of approximately 2.5 cm. They are made of various materials (metal, hard plastic, wood) and are usually provided with a pointed metal end. They are painted red and white with black marking at the 1 meter point. The lengths of the red/white sections are 50 cm.</p> <p>As a cheaper alternative a hard wood lath (must be straight), which is pointed at one end, can also be used as a ranging rod. At the same time it can be used as vertical part of the profile board (see below).</p>	

Boning Rods (also called Travellers):
 Boning rods are T-shaped and of a uniform height. They can easily be manufactured by nailing a wooden plank of 80 cm length and 10 cm height on another plank of 130 cm length and 10 cm width so that the end result looks like a "T". The horizontal plank should be painted in clearly visible colours. Boning rods have to be used in a set of three.

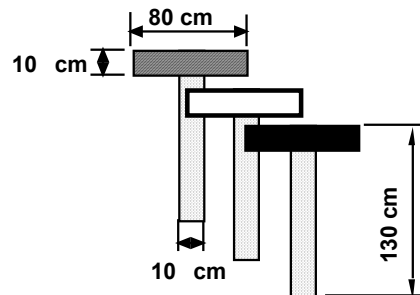

Profile Board:
 A profile board is designed in such a way that it can be attached to a ranging rod. It has a screw mechanism that enables the profile board to slide up and down on the ranging rod and be fixed at any desired point simply by tightening the screw. A long lasting profile board is the one made from thin steel plate (40 cm x 10 cm) welded to a short length of metal tubing that can slide up and down and can be clamped to the metal rod.

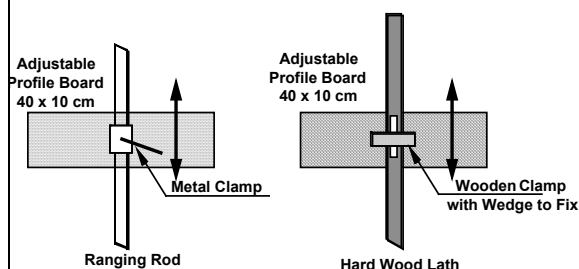

Alternatively wooden profile boards can be attached to a hard wood rod and fixed with a wedge pushed into the wooden clamp.

Templates: are used to control certain shapes of the road. For example, to control the correct shape for the slope and ditch, a template of the standard slope-ditch size can be used by the labourers to continuously check whether the correct shape is being dug. Templates are very useful control aids as any labourer can see the exact size and shape of the work she/he is required to carry out. They are usually made of wood and tailor-made for each particular project in accordance with the standard measurements (see specifications).

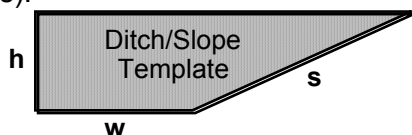

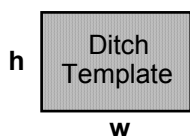

h = height of ditch
 w = width of ditch
 s = slope

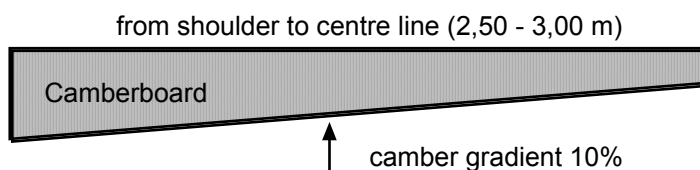

h = height of ditch
 w = width of ditch

Note:
 Always use templates together with spirit level

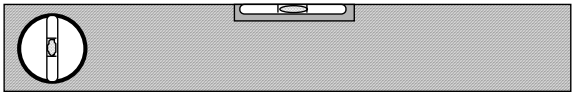

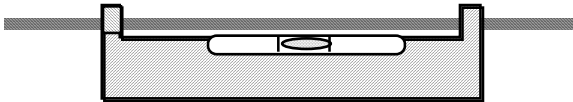
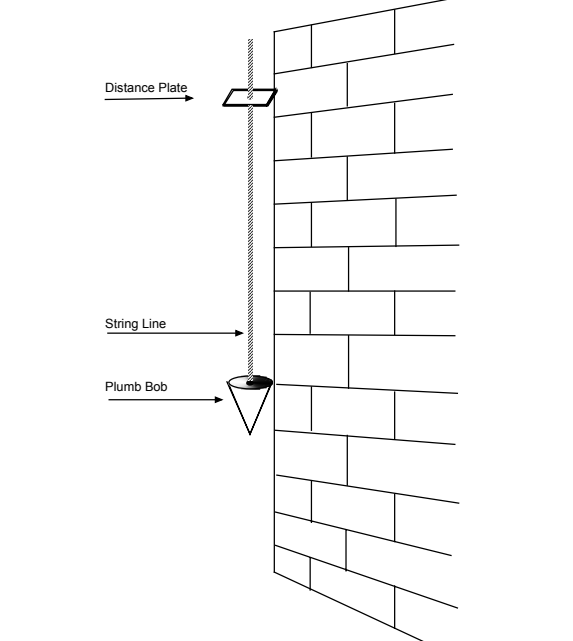
<p>Spirit Level: Spirit levels are available in all different sizes. For construction work robust and long spirit levels are ideal. The longer the spirit level the more exact the measurement will be. Always ensure that the spirit level is properly adjusted before you buy it.</p>	
<p>Straight-Edge with Spirit Level: If the spirit level is not long enough, then a straightedge of 2.50 m to 3.50 m, usually out of wood, can be used. Always ensure that your straightedges on site are actually straight on both sides.</p>	
<p>Line Level: A line level is a small spirit level of about 80 - 120 mm length. It has a hook on each end of the level which is used for hooking the level onto a smooth line. The level is used together with a line, ranging rods (or profile boards) and a tape measure. The line level requires two people to operate.</p> <p><i>The line level can be used to:</i></p> <ul style="list-style-type: none"> • transfer levels • check existing gradients • set out gradients <p><i>Always check:</i></p> <ul style="list-style-type: none"> • that the line is smooth or of nylon • keep the line tight, • level is in the middle between the two ranging rods, • check the accuracy of the level regularly. 	 <p><i>Check accuracy of line level:</i></p> <ul style="list-style-type: none"> • Place two ranging rods 20 m apart, • Fix a line on the 1m-mark on one rod and transfer the level to the other rod = mark this level. The line should be kept tight and the bubble on the line level should be in the middle, • Keep line in place, unhook the line level and turn it around • Adjust the line again and make sure the bubble on the line level is in the middle. Mark the new level on the rod and measure the difference between the two levels.
<p>Plumb Bob: The plumb bob is usually used by masons to check the vertical alignment of walls. On road sites this is the case for structure work. The distance plate is slightly wider than the plumb bob itself and can be freely moved along the string line. In this way the plate can be held against the top of the wall while the plumb bob hangs on the lower end. If the plumb bob nearly touches the wall, then the top and bottom point of the wall are in a vertical line. The alignment of the wall can then be checked by sighting the string line with the wall line. If they are parallel to each other then the wall is straight (vertical).</p>	

D.3 SETTING OUT A STRAIGHT LINE

For several activities straight lines must be established, like the centre line on straight sections of road, long mitre drain outlets, establishment of structure lines, etc.

Shift the rod in the middle until all 3 rods are in one straight line, then place pegs where needed, e.g. every 10 metres for the centre line.

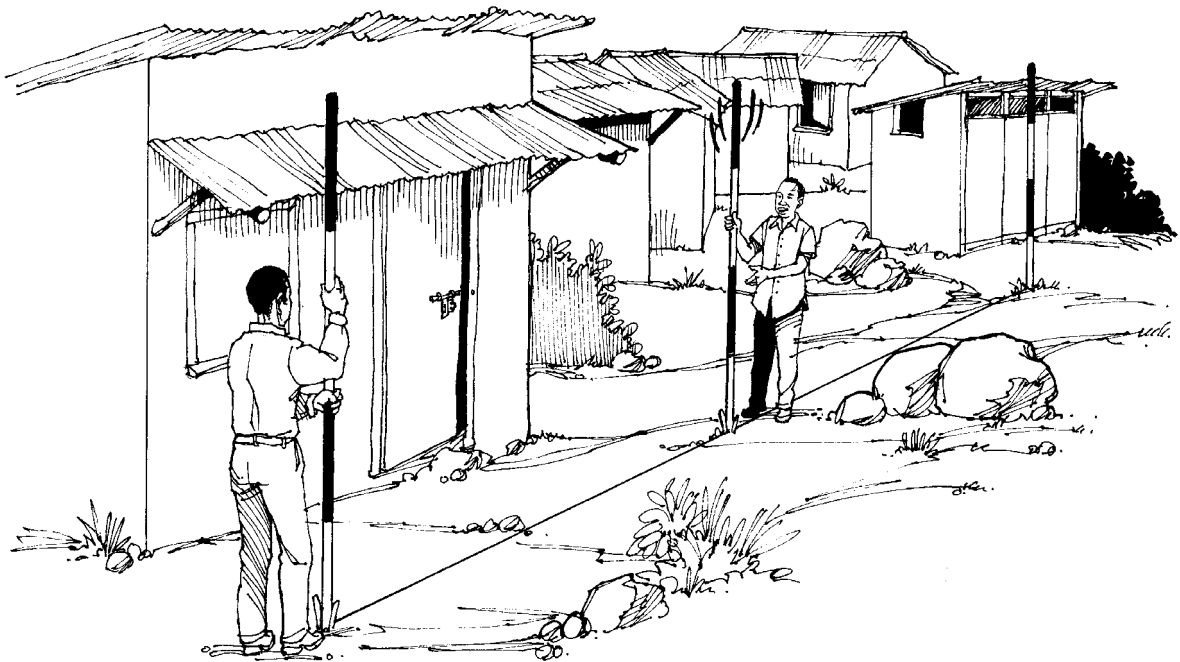

D.4 SETTING OUT ANGLES

Setting out of a right angle (90°):

This is mostly needed when setting out slots (transversal guides for establishing the formation base level → see module E). The right angle is established by measuring a triangle with side lengths of 3, 4 and 5 metres.

- Measure the length AB of 4 metres along the centreline of the road. Set pegs exactly at points A and B.
3. Hold the zero point of the tape measure on the peg A
4. A second person holds the mark 8.00 metres on the tape measure on peg B.
5. A third person holds the tape measure on mark 5.00 metres, which will lead to point C when the tape measure is pulled tight. Set a peg on point C.

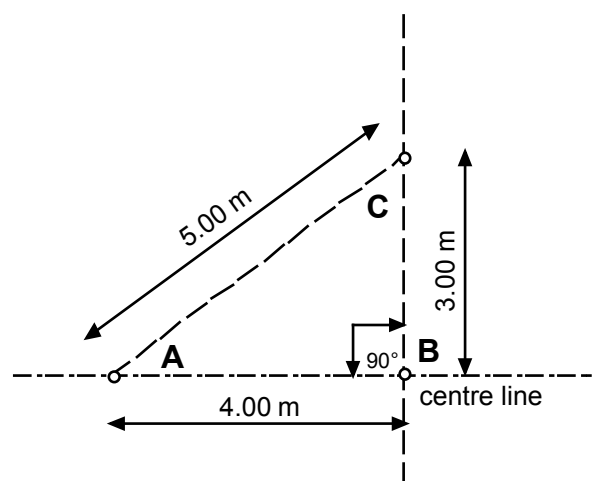

Setting out of a 45° angle:

- ◆ Establish first a right angle as shown above.
- 2. Set out the same distance on both of the two lines (L) starting from the intersection point B, e.g. 3.00 metres and fix the pegs A and C.
- 3. Span a string line between points A and C and measure this length A to C.
- 4. Divide the length A to C by **two** and set the peg **D** exactly in the middle of this length.
- 5. Establish the new line **B to D** with a string line and extend beyond peg D if necessary.

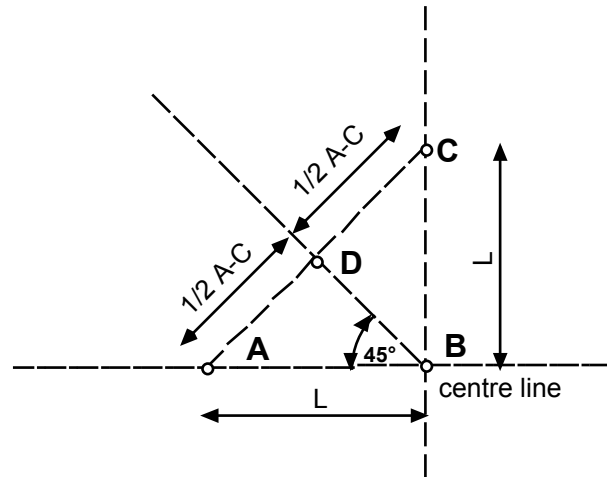

Setting out of 30° and 60° angles:

- ◆ Establish first a right angle as shown above.
- 7. Set out the same distance on both of the two lines (L) starting from the intersection point B, e.g. 3.00 metres and fix the pegs A and C.
- 8. Span a string line between points A and C and measure this length A to C.
- 9. Divide the length A to C by **three** and set pegs **D (for 30°)** after a 1/3rd of the length A to C, or **E (for 60°)** after 2/3rd of the length A to C.
- 10. Establish the new lines **B to D** or **B to E** with a string line and extend beyond peg D or E if necessary.

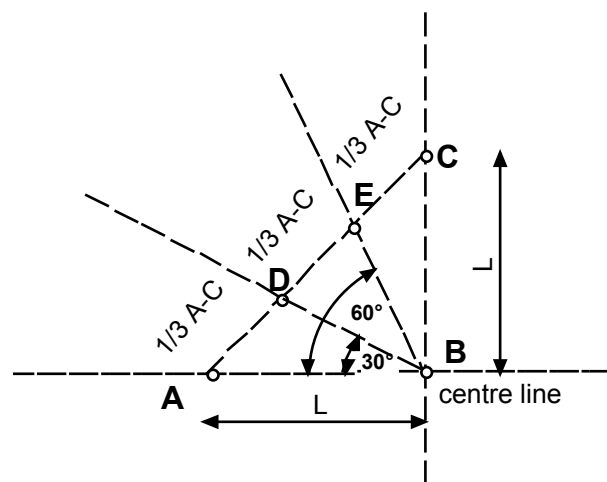

D.5 SETTING OUT HORIZONTAL CURVES

There are four basic methods of setting out curves that may be used for labour-based road construction:

Curves Setting out methods:

METHOD	APPLICATION
String method	Suitable only for curves with a radius of less than 30m. The area must be flat and free from obstructions. Mo and hairpin bends.
Quarter method	Suitable for short curves where a stringline can be stretched unobstructed between the ends of the two straight lines.
Tangent method	Suitable for any curves where the align 90°. The intersection point for the two between it and the road must be flat and
Offset method	Suitable for any curve. However, it requires a trial-and-error approach when applied to an existing alignment.

On labour-based sites in Zambia the string method and the tangent method are usually applied:

String Method

- Determine the edges of the carriageway and the centre line on both straight lines and mark them with pegs and strings.

6. Set out lines 1 and 2 parallel to the inner edge of the road with the selected radius "r" from it. Mark the two lines with pegs and strings
7. The point of intersection is the place where line 1 and line 2 cross each other = mark this point with a strong coloured peg.
8. Use a string of the radius distance length to set out the curves.

Tangent Method

1. With the help of ranging rods (or vertical part of profile boards), establish the point of intersection D along the centre line of the road by extending lines Q, R and S, T.
2. Choose the most suitable tangent lengths (equal lengths) and establish points B and C (for example DB = DC = 30m).
3. Establish points B and C with pegs.
4. Divide the tangent lengths DB and DC into an equal number of parts and number them as shown in the drawing.
5. The points on the curve lie at the inner most intersection points. Establish this line with pegs and string.
6. Check the radius of the curve. If the radius is insufficient move points B and C apart and restart. Place intermediate pegs if necessary to form a smooth curve with a stringline.

D.6 SETTING OUT GRADIENTS AND LEVELS

In order to check existing gradients or to set out new ones over relatively short distances (up to 20m) the line and level method is simple and sufficiently accurate (± 0.5 cm).

Checking (finding) an existing gradient:

1. Fix ranging rods vertically at the two end points of the slope firmly into the ground.
2. Tie the string line at the 1 metre mark of the ranging rod at the higher point of the slope.
3. Fix the string line at the lower ranging rod, hook the line level at the middle point between the two ranging rods and move the string line at the lower point ranging rod up or down until the level bubble is exactly in the middle. Mark this level at the lower ranging rod, turn the line level around and mark the level again. Measure the middle of the difference of the two marks = this is the exact horizontal level transferred from the higher to the lower ranging rod.
4. Now measure the difference between your horizontal level mark and the one metre mark at the ranging rod (= **D**).
5. Measure the exact distance (length) between the two ranging rods (= **L**).
6. Calculate the percentage of the slope. The distance between the two ranging rods represents 100%. The calculation is therefore as follows:
D divided by L multiplied by 100% = the percentage of the slope. Use centimetres for all measurements.

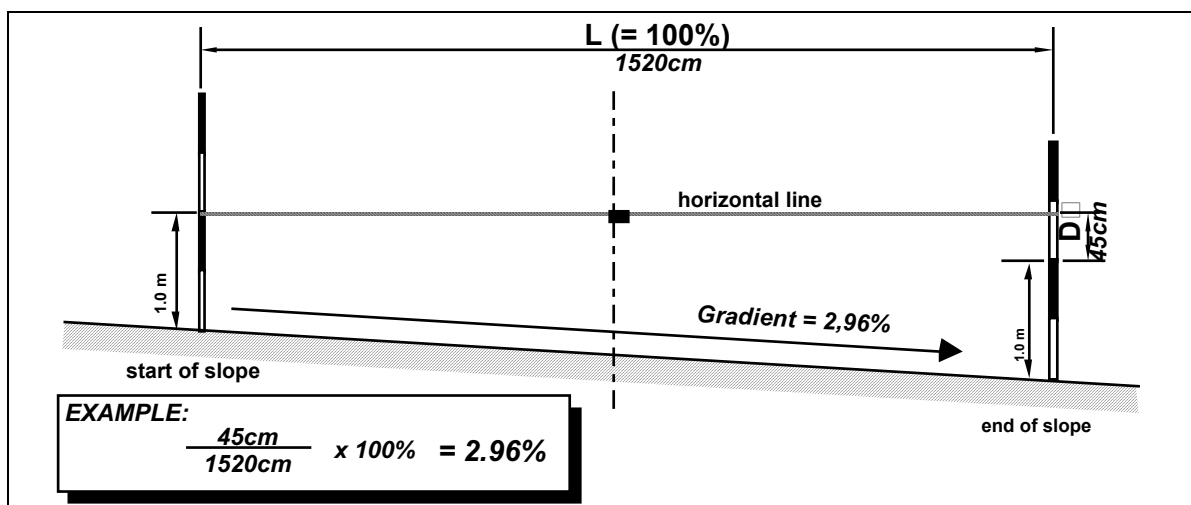

Setting out a given gradient:

1. The distance **L** represents 100%,.
2. Define **D**: = **multiply L with given gradient** (e.g. 3%=3/100=0.03, as in example below).
3. Fix the line level to the lower ranging rod so that the line is horizontal and mark the point on the ranging rod,
4. Now **add D to 1m** and measure the distance (D+1m) from the level mark downwards. You will see that in order to be able to measure this new height, you need to dig a small slot next to the ranging rod. Dig the slot in small steps until you can measure the exact height (D + 1 m). The bottom of this slot is now at the required level.
5. In order to transfer the gradient uniformly you have to use boning rods or profile boards applying the method described below = set a boning rod at each end point, every few metres dig a small slot, set the boning rod at the bottom of the slot and deepen the slot until all three boning rods are in line with one another.

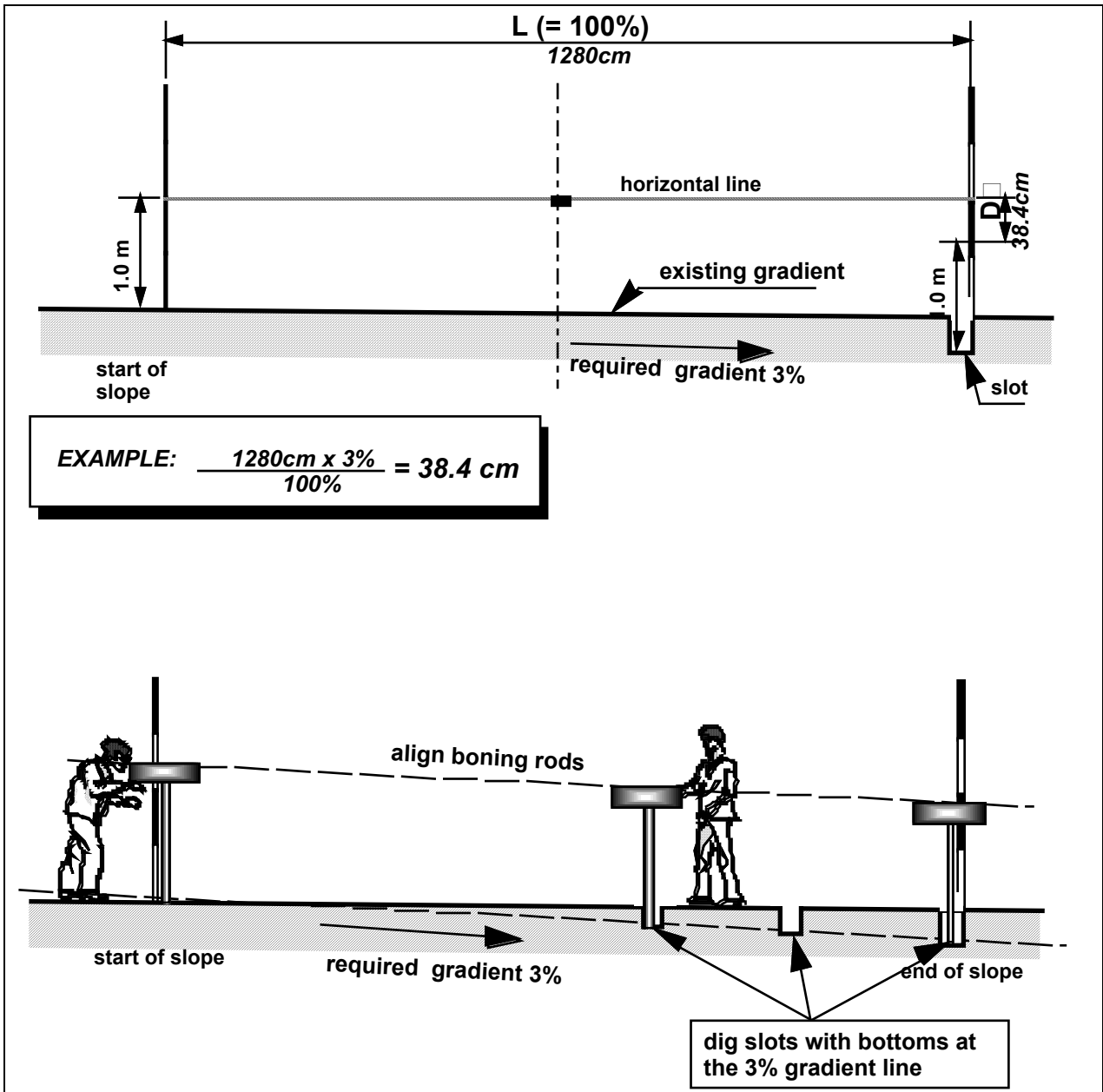

Establishing levels:

The above method applies in principle also for the transfer of levels from an established reference level, e.g. centre line level. The example explains how the ditch level can be established if the centre line levels are set:

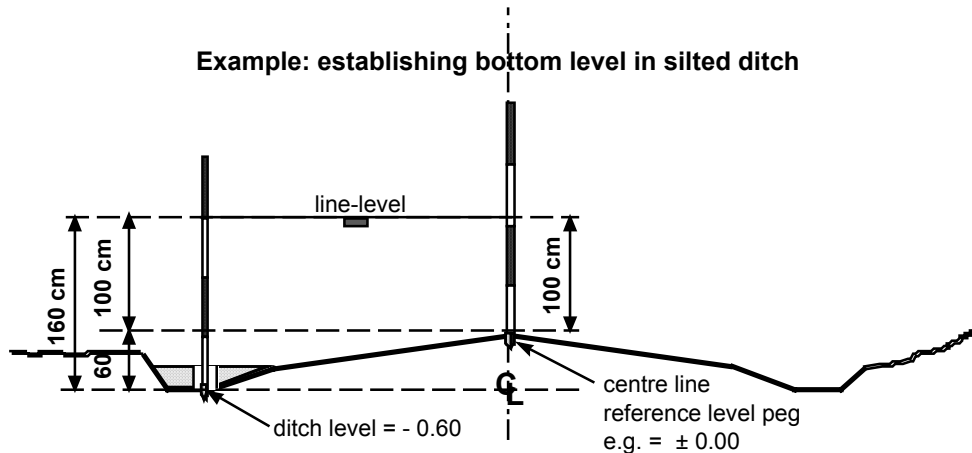

1. Place a ranging rod on the centre line reference level and make a mark on the rod 100 cm above this level.
2. Dig a slot in the silted ditch to the approximate level and place another ranging rod in it.
3. Fix the line level on the 100 cm mark of the centre line ranging rod and transfer this level to the ranging rod in the ditch. Mark this level on the rod.
4. Measure the anticipated level-difference (in this case 60 cm) plus 100 cm (total 160 cm) from the mark downwards and establish the correct level of the ditch bottom by either digging further down or adding some material.

Checking uniformity of gradient:

In order to achieve a reasonably smooth and aligned surface (horizontal or gradient) without unnecessary depressions or humps it is necessary to control the levels. The simplest method is to use a set of boning rods or travellers.

Procedure:

1. Fix boning rods/profile boards at the two ends of the straight you want to check, assuming that those two points have the level/gradient you need to maintain. If you use profile boards make sure the two end boards are fixed at the identical measure on the rod, e.g. 1.30 metres from the ground.
2. While sighting from one end to the other, let an assistant place the third boning rod/profile board at any point you want to check in-between the two end rods. Then sight from the first to the last board and check whether the intermediate board is in line with the two end boards. If not, you need to correct (lift or lower) until the intermediate board is in line. Set a reference peg with the correct level.

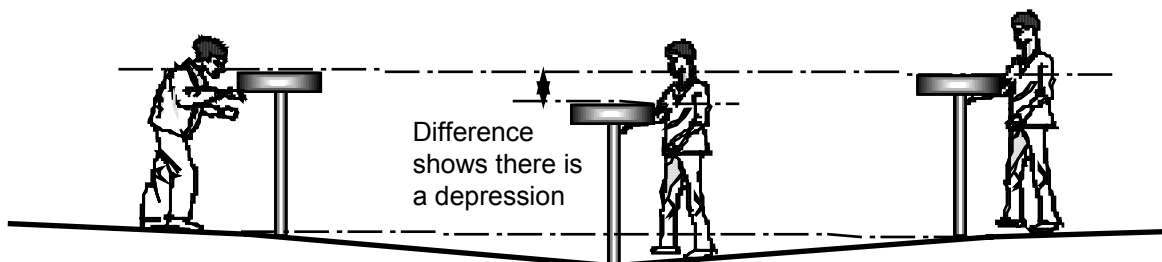

MODULE E:

LABO

E.1	Introduction	E-1
E.2	Common Terms	E-1
E.3	Standard Cross-Sections for Rural Roads	E-5
E.4	Work Management	E-12
E.4.1	Site Inspection	E-12
E.4.2	Site Work Planning	E-13
E.4.3	Site Camp Establishment	E-16
E.4.4	Site Organisation and Staffing	E-18
E.4.5	Recruitment of Labour	E-18
E.5	Site Planning, Reporting and Monitoring	E-18
E.6	Earth Road Works (Activity Sheets)	E-19
E.7	Quality Control for Earth Road Works	E-38
E.8	Culverts	E-38
E.8.1	Definitions	E-38
E.8.2	Manufacturing Culverts	E-39
E.8.3	Setting Out	E-40
E.8.4	Bedding and Haunching	E-44
E.9	Small Structure Works	E-46
E.9.1	Introduction	E-46
E.9.2	Common Structures for Rural Roads	E-46
E.9.3	Important Considerations for the Construction of Structures	E-48
E.9.4	Gabion Works	E-49
E.10	Gravelling	E-51
E.10.1	Planning and Organising Works	E-51
E.10.2	Equipment and Tools	E-52
E.10.3	Gravelling Activities (Activity Sheets)	E-53
E.10.4	Quality Control for Gravelling	E-61

E.1 INTRODUCTION

Labour-based road construction or rehabilitation is the work method that utilises locally available resources, like skilled and unskilled labour, material and light equipment. Design, work preparation and contract documentation are usually specifically tailored for this approach.

Most of the works are carried out using local labour and only those activities that labour cannot manage is done using intermediate equipment, like tractors with trailers, tippers, pedestrian rollers, etc. The end result of the work is expected to be of high quality as stipulated in the contract specifications. To achieve this, and to be able to carry the work within the given timeframe, good site management and a structured work approach is required from contractors. The most demanding task is to manage a large, mainly unskilled labour force.

The following sections assist in the step-by-step organisation and implementation of such works.

E.2 COMMON TERMS

General

Paved Road	For the purpose of this handbook a paved road is a road with a bituminous surfacing .
Unpaved Roads	For the purpose of this handbook an unpaved road is a road with a soil or gravel surface .

Components o

Blinding	<p>a) A layer of lean concrete, usually 5 to 10 cm thick, placed on soil to seal it and provide a clean and level working surface to build the foundations of a wall, or any other structure.</p> <p>b) An application of fine material e.g. sand, to fill voids in the surface of a pavement or earthworks layer.</p>
Bridge	A structure usually with a span of 5 metres or more, providing a means of crossing above water, a railway or another obstruction, whether natural or artificial. A bridge consists of abutments, deck and sometimes wingwalls and piers.
Camber	The road surface is normally shaped to fall away from the centre line to either side. The camber is necessary to shed rain water and reduce the risk of passing vehicles colliding. The slope of the camber is called the crossfall. On sharp bends the road surface should fall directly from the outside of the bend to the inside which is called 'superelevation'.
Carriageway	The road pavement or bridge deck surface on which vehicles travel.

Causeway, Vented Drift or Vented Ford (also Irish Bridge)	Low-level structure constructed across streams or rivers with openings to permit water to pass below road level. The causeway may become submerged in flood conditions.
Centre Line	Line running along the centre of the road (important in surveying and setting out the alignment). Longitudinal sections usually run along the road centre line.
Chainage	A term frequently used for describing distances measured along the centre line of a road and shown written on pegs or boards, which are fixed in the road reserve.
Coffer Dam	A temporary dam built above the ground to give access to an area which is normally, or has a risk of being, submerged or waterlogged. Cofferdams may be constructed of soil, sandbags or sheetpiles.
Crown	The highest point of the cross section of the road carriageway, usually the centre line.
Culvert	A structure allowing water to flow under the road and having an open span of normally between 0.5 and about 5 meters. The opening may be round, rectangular or arched. The invert, walls and soffit often form an integral unit.
Cut (cutting)	Excavation in natural ground usually with graded slopes.
Deck	The part of a bridge that spans between abutments or pier supports, and carries the road traffic.
Drift or Ford	A stream or river crossing at bed level over which the stream or river water can flow.
Embankment	Constructed earthworks below the pavement raising the road above the surrounding natural ground level.
Formation	The shaped surface of the earthworks, or subgrade, before constructing the pavement layers.
Layby	An area adjacent to the road for the temporary parking of vehicles.
Margins	The right of way/land area maintained/owned by the road authority.
Parapet	The protective edge, barrier, wall or railing at edge of a bridge deck.
Pavement	The constructed layers of the road on which the vehicles travel.
Roadbase and Subbase	Pavement courses between surfacing and subgrade.
Roadway	The portion of a highway, including shoulders, for vehicular use.
Scuppers	Drainage pipes or outlets in a bridge deck.
Shoulder	Paved or unpaved part of the highway next to the outer edge of the pavement. The shoulder provides side support for the pavement and allows vehicles to stop or pass in an emergency.

Slope	A natural or artificially constructed soil surface at an angle to the horizontal.
Stringer	Longitudinal beam in a bridge deck or structure.
Subgrade	Upper layer of the natural (in-situ material) or imported soil (free of unsuitable material) which supports the pavement.
Surfacing	Top layer of the pavement. Consists of wearing course, and sometimes a base course or binder course.
Surface Treatment	Construction of a protective surface layer e.g. by spray application of a bituminous or tar binder, blinded with coated or uncoated aggregate.
Traffic Lane	The portion of the carriageway defined by road markings for the movement of a single line of vehicles.
Transverse Joint	Joint normal to, or at an angle to, the road centre line.
Wingwall (and Headwall)	Retaining wall at a bridge abutment (or culvert) to retain and protect the embankment fill behind the abutment (or culvert fill).

Drainage

Apron	The flat invert of the culvert inlet or outlet.
Basin	A structure at a culvert inlet or outlet to contain turbulence and prevent erosion.
Berm	A low ridge or bund of soil to collect or redirect surface water.
Cascade	A drainage channel with a series of steps, sometimes with intermediate silt traps or ponds, to take water down a steep slope.
Catchpit	A manhole or open structure with a sump to collect silt.
Chute	An inclined pipe, drain or channel constructed in or on a slope.
Counterfort Drain	A drain running down a slope and excavated into it. The excavation is partly or completely filled with free draining material to allow ground water to escape.
Cut-off/Catch-water Drain	A ditch constructed uphill from a cutting face to intercept surface water flowing towards the road.
Debris Rack or Grill	Grill, grid or post structure located near a culvert entrance to hold back floating debris too large to pass through the culvert.
Ditch (Drain)	A long narrow excavation designed or intended to collect and drain off surface water.
Drainage	Interception and removal of ground water and surface water by artificial or natural means.
Drainage Pipe	An underground pipe to carry water.

Flow Spreader	A structure designed to disperse the flow at the outfall of a ditch or drain to minimise the risk of erosion down stream.
Invert	The lowest point of the internal cross-section of a ditch or culvert.
Manhole	Accessible pit with a cover forming part of the drainage system and permitting inspection and maintenance of underground drainage pipes.
Mitre Drain	Or Turn Out Drain, leads water away from the Side Drains to the adjoining land.
Outfall	Discharge end of a ditch or culvert.
Permeable Soils	Soils through which water will drain easily e.g. sandy soils. Clays are generally impermeable except when cracked or fissured.
Riprap	Stones, usually between 5 to 50 kg, used to protect the banks or bed of a river or watercourse from scour.
Scour Checks	Small checks in a ditch or drain to reduce water velocity and reduce the possibility of erosion.
Soffit	The highest point in the internal cross-section of a culvert, or the underside of a bridge deck.
Underdrainage (Sub-Soil Drainage)	System of pervious pipes or free draining material designed to collect and carry water in the ground.
Weephole	Opening provided in retaining walls or bridge abutments to permit drainage of water in the filter layer or soil layer behind the structure. They prevent water pressure building up behind the structure.

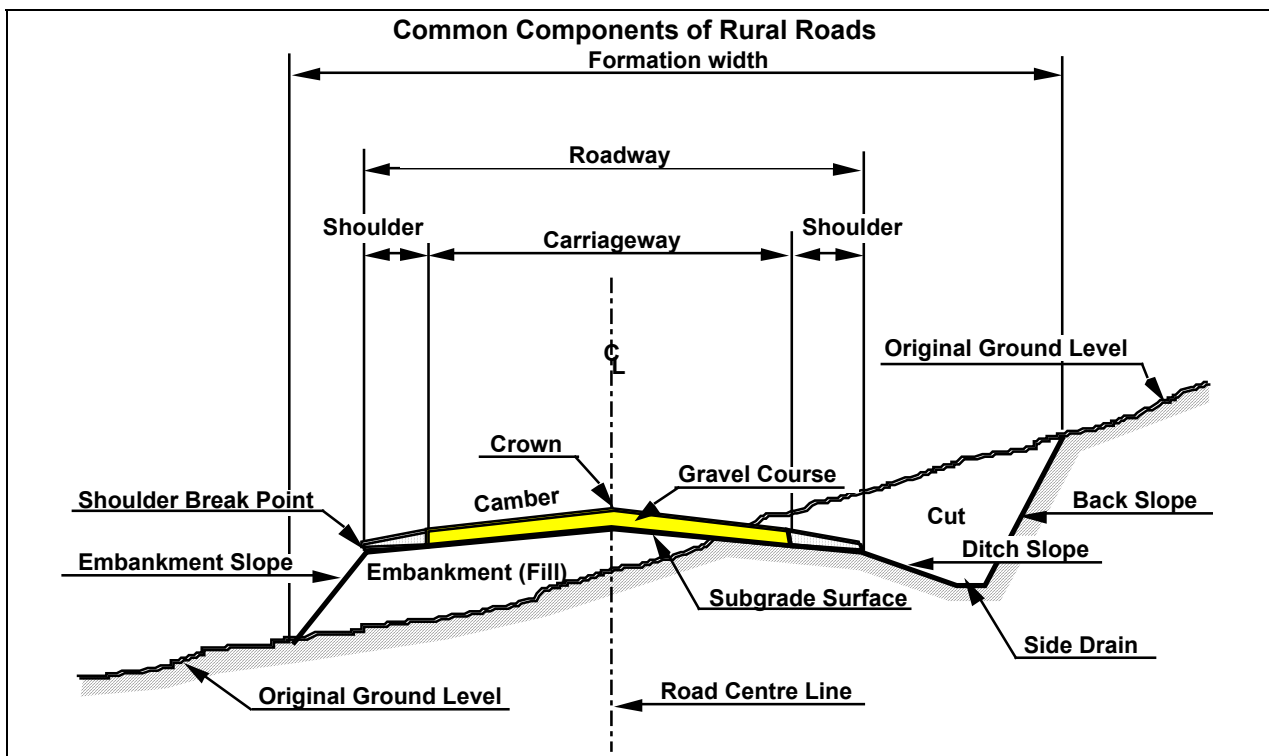

E.3 STANDARD CROSS SECTIONS FOR RURAL ROADS

A1: Standard; for flat or undulating terrain (as per Ministry of Works and Supplies Specifications)

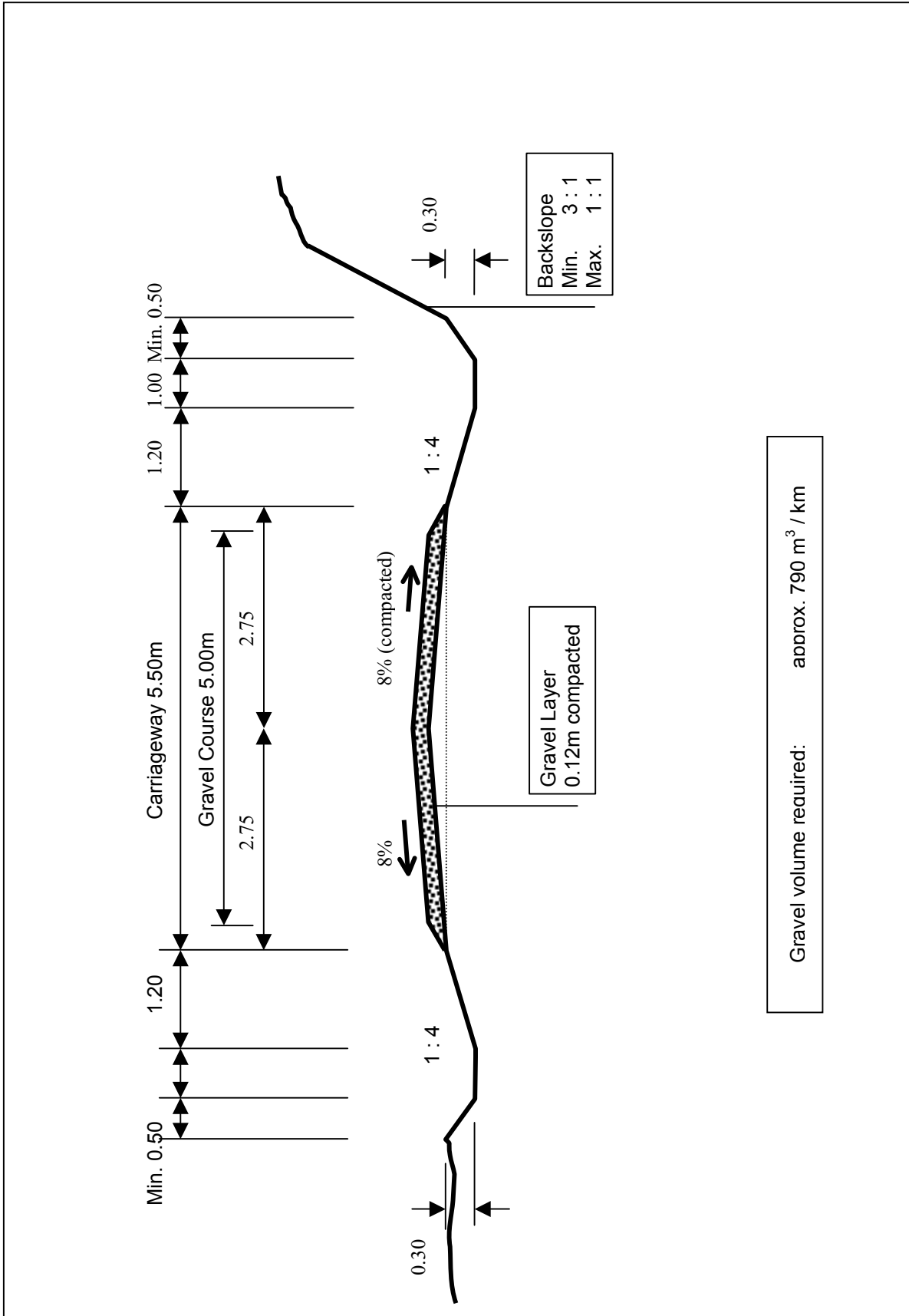

A2: Standard; for flat or undulating terrain (as per Ministry of Local Government and Housing specification)

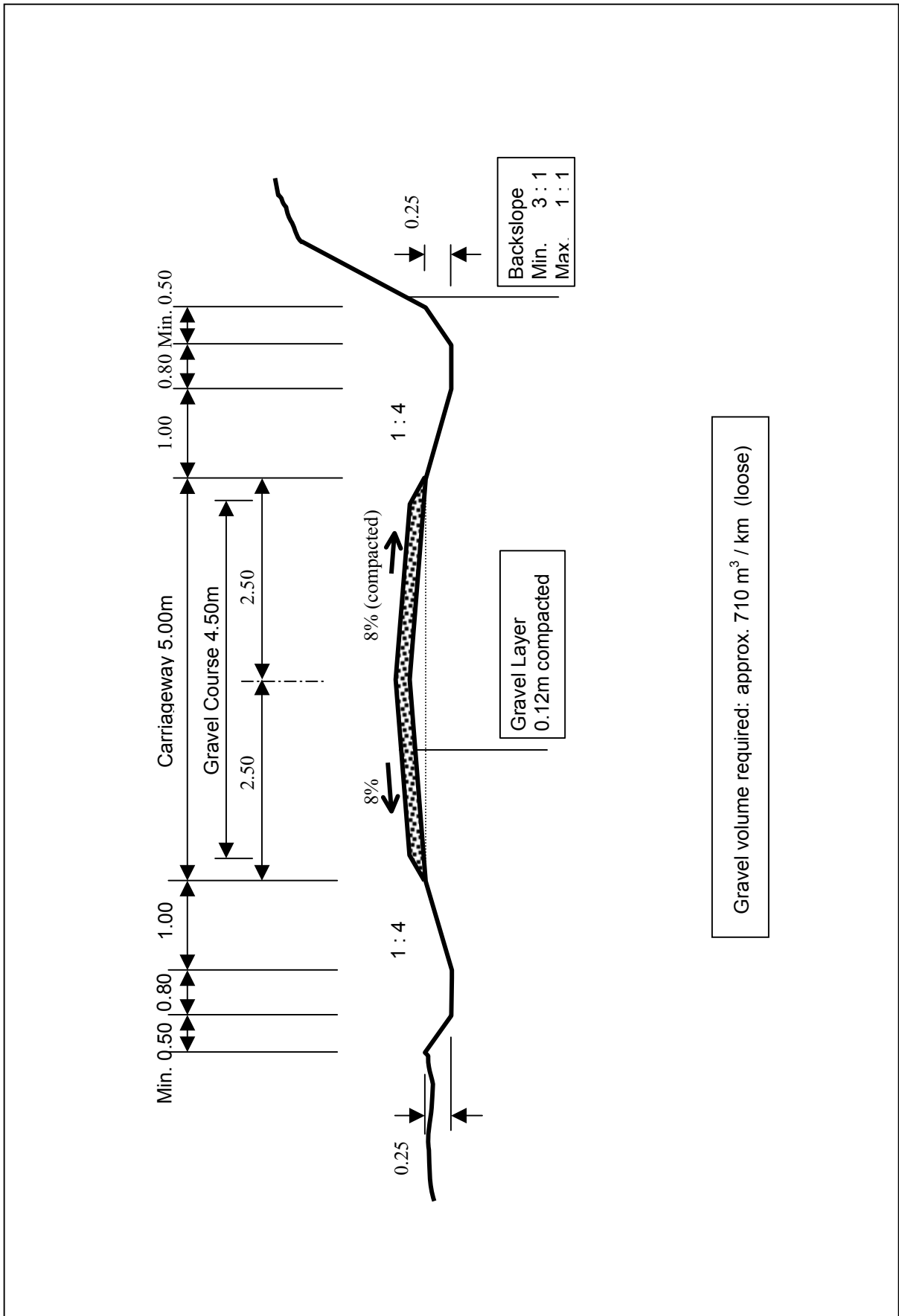

B: Reduced Cross-Section; for very low traffic volumes in flat or undulating terrain

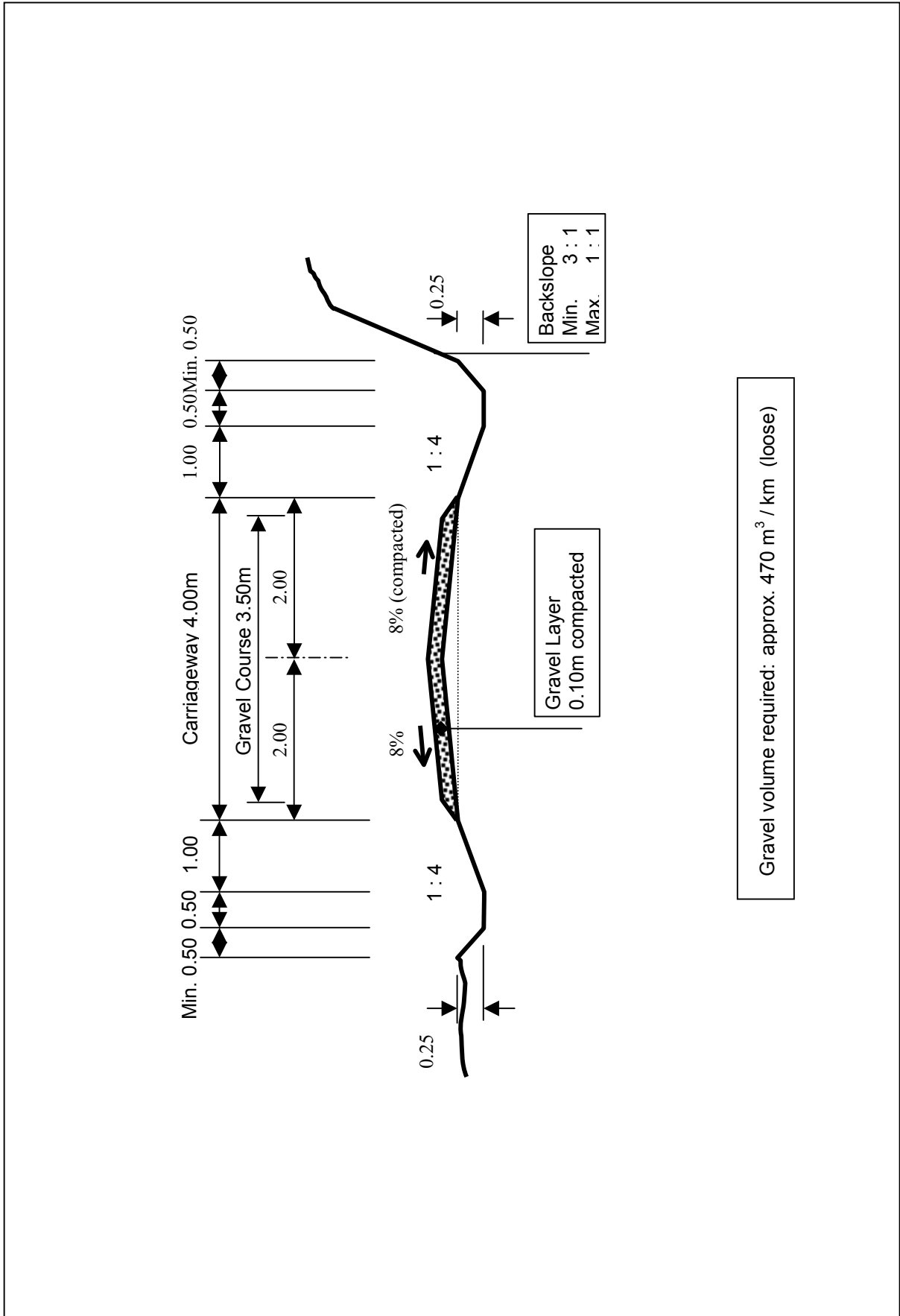

C: Mountain Road Cross-Section; for severe terrain and very low traffic volumes

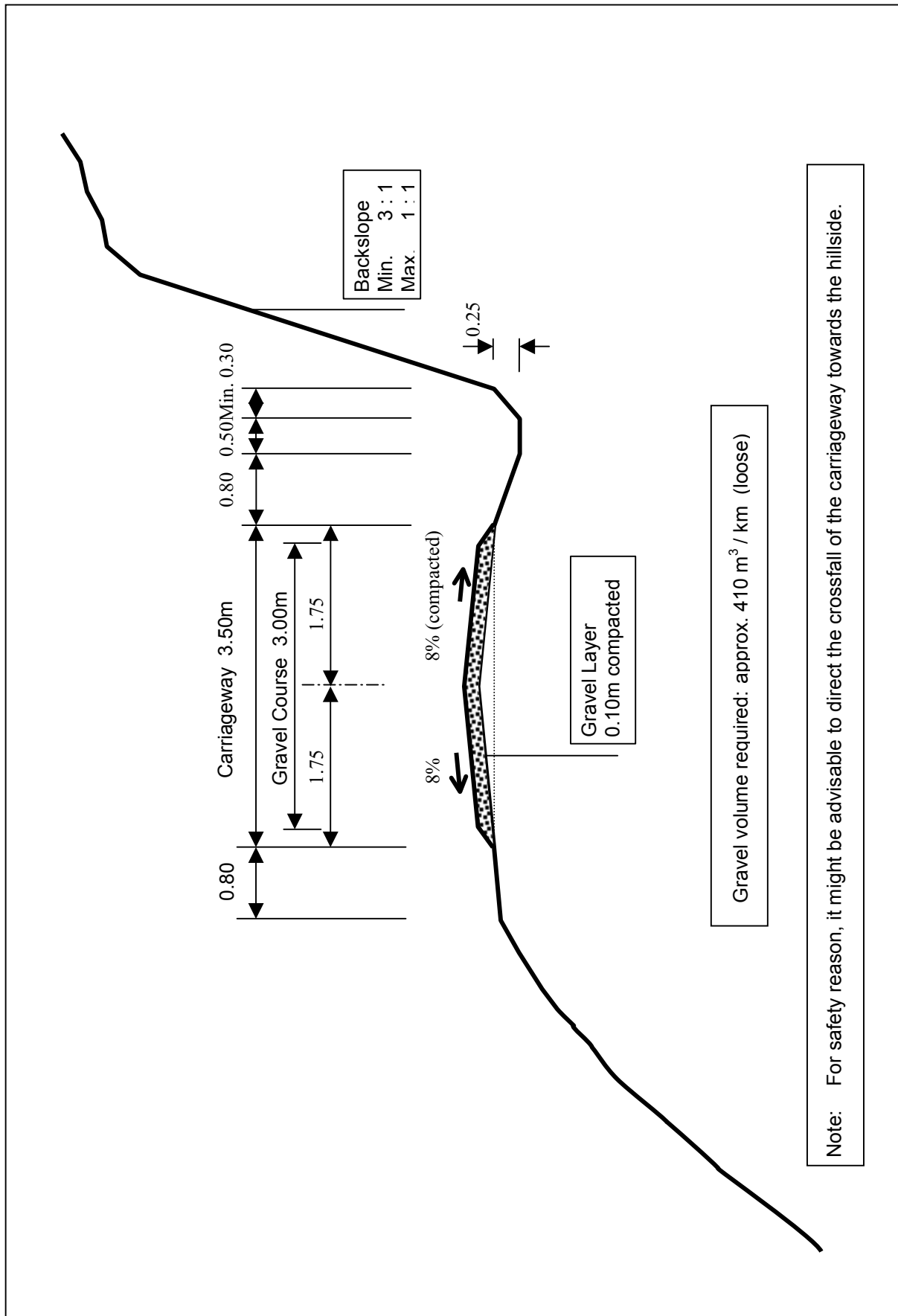

D: Black Cotton Soil Cross Section

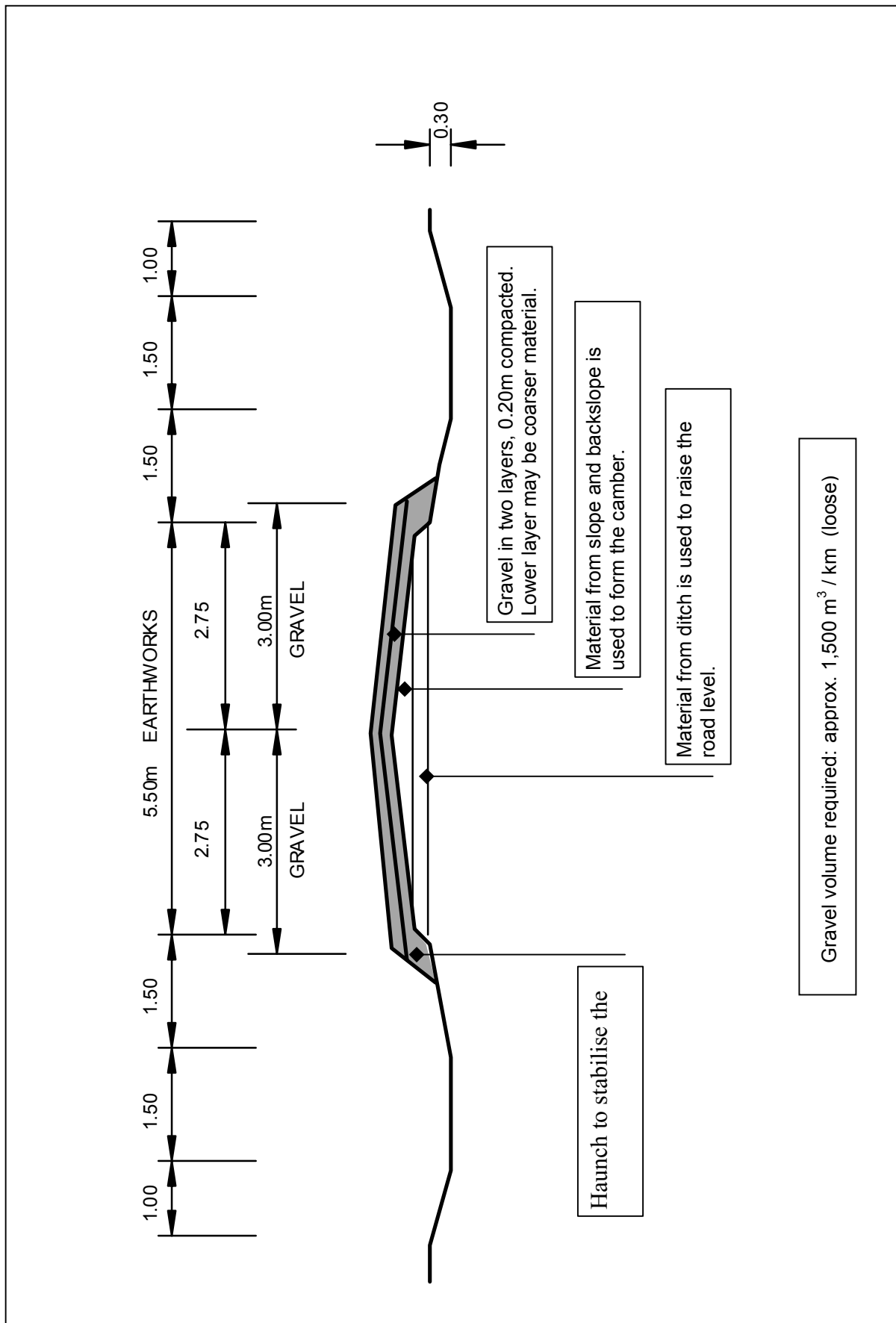

E: Embankment

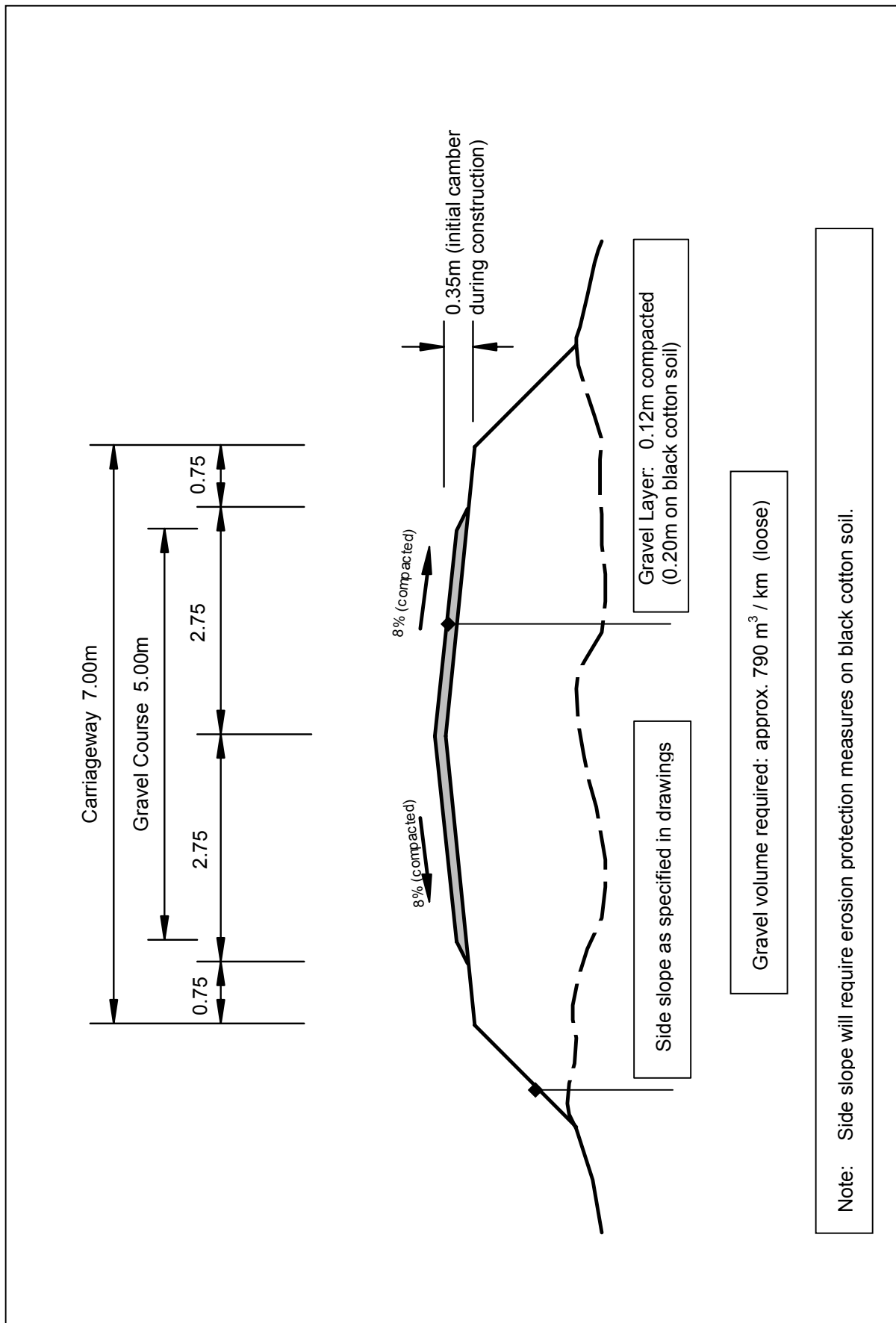

F: Superelevation

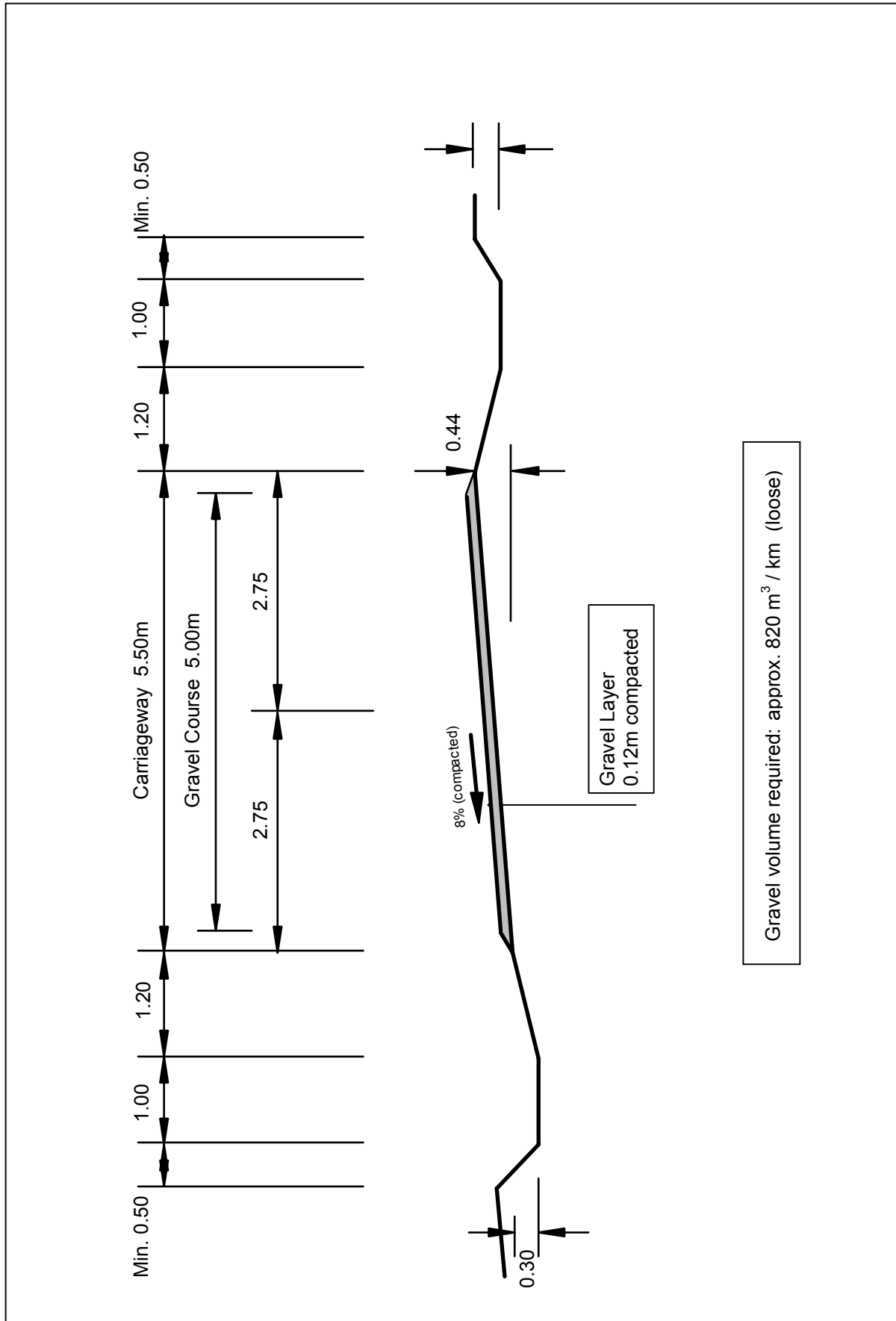

E.4 WORK MANAGEMENT

E.4.1 Site Inspection

Before tendering and commencement of works, the contractor should walk the entire alignment of the road together with the site supervisor and carry out a thorough site inspection. It is necessary to collect all data that is important for site planning (see check suggested checklists below):

Camp Site and Labour:

- Where are the best locations for site camps (considering distance to site, water availability, access to market and health centres, security, etc.)?
- How many camp sites are required (at any one time / do you need to shift campsites during the work / how many times)?
- Is any preparation work required for the camp, e.g. access road, bush clearing, etc.?
- What is the average walking distance for the labourers, a.) from their homes to the camp, and b.) from the camp to the sites (gravelling site, quarry, reshaping site)?
- What is the availability of skilled/unskilled labourers?
- Can you get support from the local authorities to recruit and organise labour?
- Who are the people 'who matter' in the area of your operation?
- What is the transport distance from the company's base to the camp?
- What mode of transport is required and how many trips (camp facilities, tools, fuel, spares, material, supervision, payments, etc.)?

Road Condition:

What is the existing condition of the track/road before work commences in comparison to the required standards?

- Drainage (are any drainage facilities in place? If yes, what is their quality? Are there special problems with the drainage?)
- Formation (are there any section of the track/road where there is an existing formation?)
- Structures (are there already structures in place and what is their condition?)
- What is the quality of the in-situ soil where the road will be constructed? Are there sections with weak soils or rock?
- Where are the trouble spots of the road and of what nature are they?
- Are there soil erosion problems along the track/road and are there other environmental problems that need to be taken care of?
- Has the alignment of the road to be constructed surveyed and set out? Do you foresee any problems with the alignment as set out?

Quarry Access:

- What is the length of the access road that you need to construct or improve and through what type of terrain does it run?
- How much work needs to be done to improve the access road so that the hauling can be carried out undisturbed? (Try to estimate the required work input and the relevant costs.)

Quarry:

- How much gravel is available in the particular quarry? You should assess the volume of gravel that you can get from the quarry and compare it with the gravel volume indicated in the contract document.
- Is the quarry located in low-lying terrain? Low-lying quarries may well become unworkable when it rains.
- Does the quality of the gravel match the contract specifications? Has the client carried out the necessary tests?
- Is water available at or near the quarry site?
- How much of an overburden will have to be removed to reach the gravel material and where can it be deposited (haul distance from quarry to depot)?
- Is the land owned by the client? Will there be a charge for its use? If it is owned by a local landowner, how much compensation will have to be paid?
- Is there a danger of soil erosion when you exploit the quarry and what would be the required protection work? For example filling of the quarry with overburden at the end of the job, etc.
- What is the size of the quarry? How can you organise the work in the quarry, e.g. how many labourers can comfortably work in the quarry, can tippers and/or tractors with trailers turn in the quarry?

Hauling:

- What is the average hauling distance for this job (there can be more than one quarry)? Definition: The average hauling distance is the distance from the quarry to the middle of the closest and furthest road section that you need to gravel.
- What is the condition of the haul route when improved (gradient, roughness, river crossings, soil, etc.)?
- Can your equipment be used for hauling on this particular haul route?

Compaction:

- Where can water be collected for compaction?
- How is the condition of the access road to this place and what improvement work is required?
- What type of compaction equipment have you available and is it suitable for this site?

E.4.2 Site Work Planning

A labour-based road construction project, with as many as 150-250 labourers and a work-site that is several kilometres long, needs to be planned and organised carefully. Otherwise it is impossible to ensure high productivity from each labour gang and an efficient use of each piece of equipment.

Important Planning Issues to Consider:

- Overall, are all required **resources (labour, equipment, material)** available and can they be optimally utilised?
- What are the **activities** to be done?
- What **quantities** of work to be considered for each of these activities?
- What is **the sequence (order)** of carrying out these activities?
- What **productivity** (guidelines) should be used?
- What is the **time available**?

Common Activities for Rural Road Construction and their Sequence:

	Operation	Activities
Earth Road Construction	<i>Supporting</i>	<ul style="list-style-type: none"> • Water carrying, providing drinking water • Store work (receiving, storing, issuing, control) • Camp maintenance • Tool maintenance and repair • Equipment maintenance and repair • Security
	<i>Setting Out and Site Clearance</i>	<ul style="list-style-type: none"> • Setting out horizontal alignment • Bush clearing • Grass cutting • Stripping and grubbing • Removing trees and stumps
	<i>Quarry Preparation</i>	<ul style="list-style-type: none"> • Clearing quarry area • Improving quarry access road • Stripping overburden • Preparing initial stockpile of gravel
	<i>Slotting and Excavation</i>	<ul style="list-style-type: none"> • Slotting or profiles • Excavating to level - • Or side borrow • First compaction
	<i>Side Drains and Camber</i>	<ul style="list-style-type: none"> • Ditching and spreading • Second compaction • Backsloping • Sloping • Camber formation • Hauling (by wheelbarrow) • Reshaping (if required) • Final Compaction
	<i>Other Drainage and Scour Checks</i>	<ul style="list-style-type: none"> • Excavating mitre drains • Excavating catch water drains • Desilting culverts • Constructing scour checks
	<i>Small Structures Major Structures Erosion Control</i>	<ul style="list-style-type: none"> • Constructing single culverts, drifts, foot bridges • Constructing multiple culverts, box culverts, bridges • Providing erosion control (planting, seeding, etc.)
Gravelling	<i>Quarry Works</i>	<ul style="list-style-type: none"> • Excavation and stockpiling
	<i>Loading and Spreading</i>	<ul style="list-style-type: none"> • Reshaping of road to be gravelled • Loading gravel • Hauling gravel • Spreading gravel • Compaction of gravel layer
	<i>Maintenance</i>	<ul style="list-style-type: none"> • Maintaining road carriageway and drainage (during defect liability period)
	<i>Reinstatement</i>	<ul style="list-style-type: none"> • Reinstating the quarry
Paving	<i>Road paving</i>	<ul style="list-style-type: none"> • Bitumen sealing • Block paving • Stone paving • Concrete slab paving

- 
- **Quality and progress of works depend to a great extent on a well structured planning approach and balanced sequencing of activities. The sequence of activities as shown in the above table should be followed.**
 - **Earth road improvement and gravelling/paving should be carried out as separate operations.**

Incentive Schemes for Labour Works:

- ◆ **Daily paid** whereby workers are paid an agreed sum of money each working day in return for a fixed number of hours.
- ◆ **Piecework** whereby workers are paid an agreed sum of money per unit of output. Determination of the daily output is usually left to the discretion of the worker.
- ◆ **Taskwork** whereby workers are paid a fixed daily wage in return for a fixed quantity of work. **This is the preferred arrangement for labour-based work = fair and easy to manage**

Establishing Task Rates

Important factors to set task rates:

- ➔ The **difficulty of the work** e.g. soil hardness/wetness, bush thickness, throwing distances.
- ➔ The **condition of the tools**
- ➔ The **temperature/weather conditions**
- ➔ The **fitness/health** of the labourers and their experience of work

To establish a task rate for an activity follow this procedure:

- Step 1** Set aside one day for a trial on the activity. Organise the labourers on a daywork basis on this activity.
- Step 2** Supervise the men/women closely, making sure that they all work hard for an eight-hour period.
- Step 3** Stop works after eight hours and measure the quantity of work, which has been done by the labourers. Divide this total work completed by the number of labourers on the activity. This gives an average task rate for the activity.

$$\text{Task Rate} = \frac{\text{Total Work Completed in 8 hours}}{\text{Number of labourers on activity}}$$

Repeat this exercise frequently and adjust the task rate so that all labourers work on site for at least six hours a day.



Task Rates are important – keep them fair!!

Productivity Rates:

Productivity of skilled and unskilled labour and equipment is the most important planning element. It determines the duration of the job and to a large extent the cost. It is therefore essential to keep detailed record of productivity rates and to monitor them on every job.



For guiding rates refer to Module M, Productivity Guidelines, of this handbook.

E.4.3 Site Camp Establishment

A site camp should be established before works commence. The location of the camp should preferably be half way along the first road section for earth road rehabilitation or close to a quarry for gravelling. Existing bad road and access conditions may however affect this decision.



For details on camp location and establishment refer to Module C of this handbook.

E.4.4 Site Organisation and Staffing

A labour-based road construction project, with as many as 150-250 labourers and a work-site that is several kilometres long, needs to be planned and organised carefully. Otherwise it is impossible to ensure high productivity from each labour gang and an efficient use of each piece of equipment.

To be able to control the work, it must be split into simple operations. Each operation is then usually assigned to a separate labour-gang with its own supervisor in charge. To check that the activities of each gang meet the targets of the overall construction schedule, a site agent is required for co-ordinating the gangs. The following figure shows the typical organisational structure that is required to manage a labour-based construction site.

Typical site organisation

company set-up	main functions
<p>contractor</p>	<ul style="list-style-type: none"> • owner of the company • overall responsibility • work planning, co-ordination and monitoring • financial planning and control
<p>site agent</p>	<ul style="list-style-type: none"> • in charge of all site operations • site planning, logistics and resource management • supervision and productivity control • site administration
<p>site supervisor construction</p>	<ul style="list-style-type: none"> • in charge of all earth road construction activities • daily site planning and supervision • labour control • overall site administration
<p>site supervisor gravelling</p>	<ul style="list-style-type: none"> • in charge of all gravelling activities • daily site planning and supervision • labour control • site administration
<p>site supervisor structures</p>	<ul style="list-style-type: none"> • in charge of all structure construction activities • daily site planning and supervision • labour control • site administration
<p>drivers and plant operators</p>	<ul style="list-style-type: none"> • in charge of their respective piece of equipment • daily maintenance • record keeping
<p>store person</p>	<ul style="list-style-type: none"> • in charge of site stores • keeping of store records • maintenance of handtools

On larger projects it might be useful to employ in addition a **site clerk** for recording daily labour attendance (musterroll), preparing monthly wage sheets, recording equipment usage, assisting in report preparation, summarising material consumption, and other administrative works

E.4.5 Recruitment of Labour

For guidelines refer to Module P, Labour Recruitment and Issues, Safety and Health on Site, of this handbook.

E.5 SITE PLANNING, REPORTING AND MONITORING

For details refer to Module N, Work Programming and Reporting, of this handbook.

E.6 EARTH-ROAD WORKS

Operations are divided into single work activities each carried out by a separate team (or gang). Usually there are distinct working teams for the following activities:

<p>Stage I Earth Road Construction and Quarry Preparation</p>	<p>Team 1: Setting Out Team 2: Clearing Team 3: Earth Works Team 4: Drainage and Structures Team 5: Quarry Preparations Team for Support (Camp) Works</p>
<p>Stage II Gravelling</p>	<p>Team 1: Quarry Works (Excavation and Loading) Team 2: Spreading and Compaction Team for Support (Camp) Works</p>

The teams (or gangs) have to be well balanced in size so that the activities follow each other at the same speed.

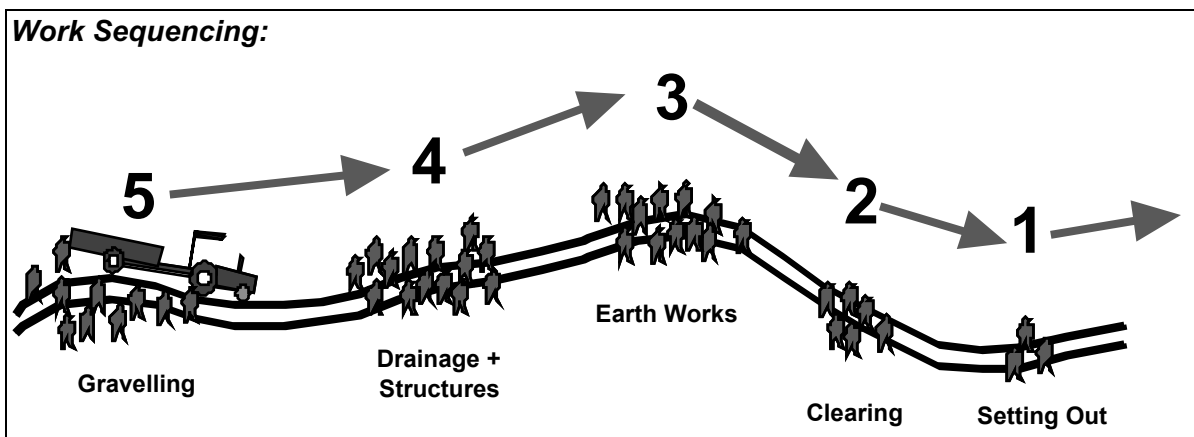

- ◆ The following Activity Sheets provide practical guidelines and checklists for all major construction activities.
- ◆ They are meant to be used as reference when preparing tenders, for developing work-plans, for instructing and training on site as well as for supervision and monitoring purposes.
- ◆ For the purpose of instructing and training the site cadre, it is therefore advisable to make copies of the Activity Sheets.

Ac **SETTING OUT**

Work Method:

Horizontal Alignment

- The horizontal alignment consists of a series of straight lines connected by curves.
- Setting out is achieved by establishing wooden centre line pegs every 10 metres along the alignment using ranging rods and tapes.
- The centreline is located within the road corridor in such a way that earthworks are minimised and obstacles (such as rocks, boulders, trees) are avoided if possible.
- If the alignment lies on steep sidelong (steep slope) ground, the centreline has to be carefully located to minimise earthworks. However it should be located in favour of cut material, rather than fill, to reduce the risk of the fill material sliding down the slope

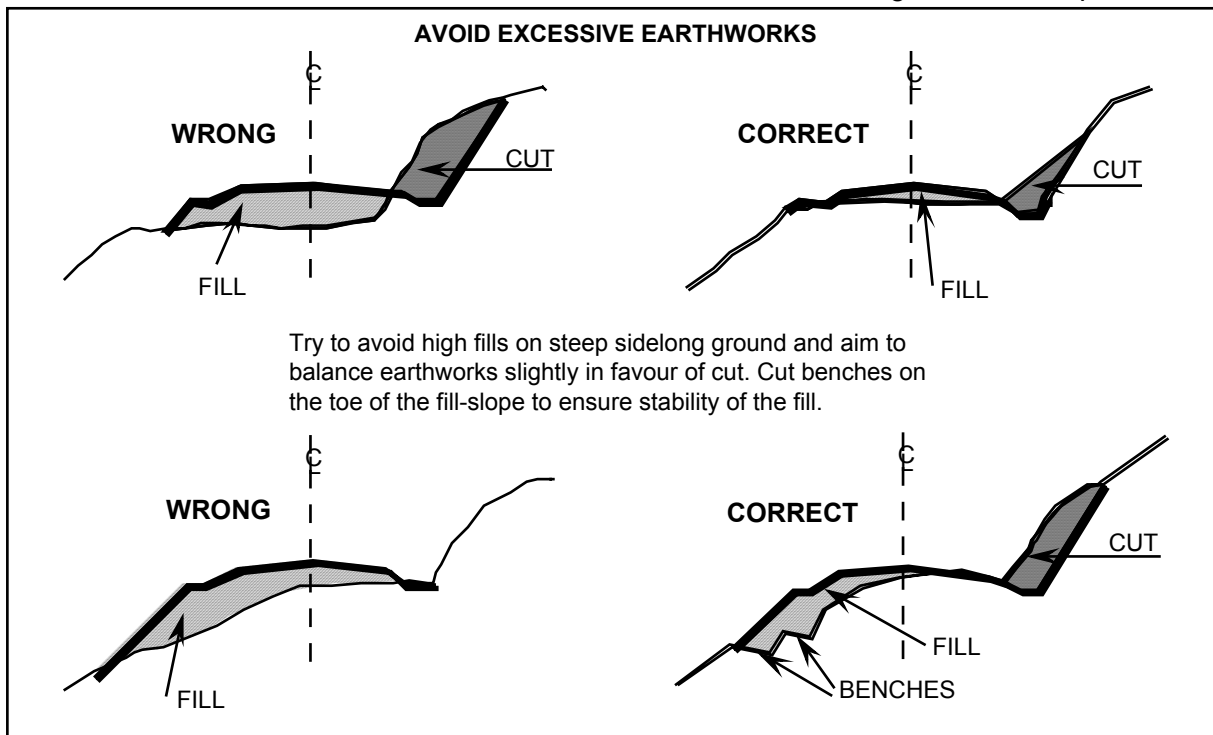

- The straights and their intersection points are established first. The connecting curves can then be set out and finally the distance pegs established → for setting out details see Module D.

Horizontal Curves

- There are four methods of setting out curves that may be used in labour-based road works. All require the use of ranging rods, tapes, string and pegs → for setting out details see Module D.

Vertical Alignment

This is determined after the preparation activities → see Activity Sheets C6A to C6D

Note

For Special setting-out cases, like hair pin bends, quarter and offset methods for curves refer to the Technical Manual, Module F-3, Setting Out

Labour:
 1 Site Supervisor (part time)
 1 Gang Leader
 2-3 Labourers

Tools and Equipment:
 • Minimum 3 ranging rods
 • Tape measures, 5 and 30m
 • Hammer

Material:
 • Strings
 • Pegs

Suggested Productivity Range:
 Daywork, (output depends on setting out task)

Actual Productivity:

--	--

Activity Sheet	C2	BU	Clearin
-----------------------	-----------	-----------	----------------

Work Method:

- Set out width of area to be cleared using pegs and strings.

A1 (STANDARD MWS)	=	14m
A2 (STANDARD MLGH)	=	13m
B (REDUCED)	=	11m
C (MOUNTAIN ROAD)	=	10m
D (BLACK COTTON)	=	16m
E (EMBANKMENT)	=	10 + (2 X EMBANKMENT HEIGHT)
F (SUPERELEVATION)	=	VARIABLES, AS PER ORIGINAL CS)
(confirm with improvement plan from engineer, if available)		

- Define quantity of work for the day and allocate labourers accordingly.
- Cut and remove all bushes and shrubs within this area and dispose outside of the cleared area. A panga (bush knife) and stick are required to cut, control and discard the vegetation.
- If it is necessary to burn the material, do it after stripping and grubbing, and within the same area. The material to be burned in controlled heaps to reduce spreading of fire.

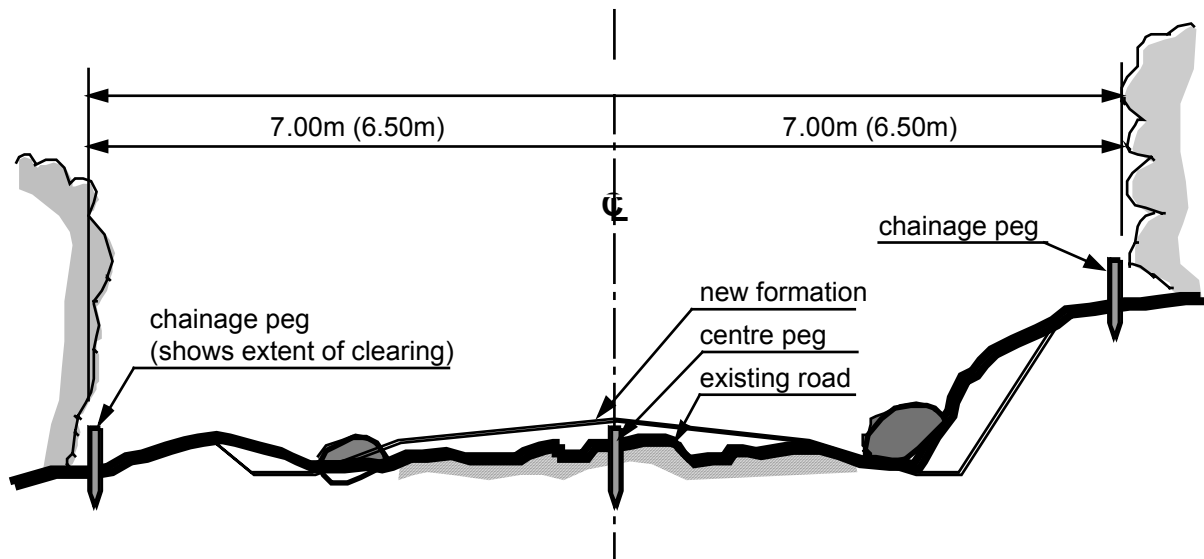

NOTE:

- disposal of shrubs outside the marked strip for bush clearing, preferably on lower side of road
- dimensions refer to cross section A1 and in brackets to A2

<p>Labour: 1 Gang Leader Labourers, according to day task</p>	<p>Tools and Equipment: • Bush knives • Hoes • Wheelbarrows</p>	<p>Material: • Strings • Pegs</p>
<p>Suggested Productivity Range: Bush clearing = 300 – 800 m² / day / labourer</p>		<p>Actual Productivity:</p>

Activity Sheet **C3**

GRASS CUTTING, STRIPPING AND GRUBBING (C)

Work Method:

- Set out width of area to be cleared using pegs and strings (two meters less than for bush clearing over the width where earthwork will take place).
- Define quantity of work for the day and allocate labourers accordingly.
- Remove all grass, upper grass roots and other vegetation (except trees) remaining after bush clearing. All topsoil should also be removed from the grubbed width as this would weaken the road if included in its construction.
- The vegetation and topsoil should be discarded outside of the grubbed width.
- Burning of material to be done outside the cleared area in controlled heaps to reduce spreading of fire.

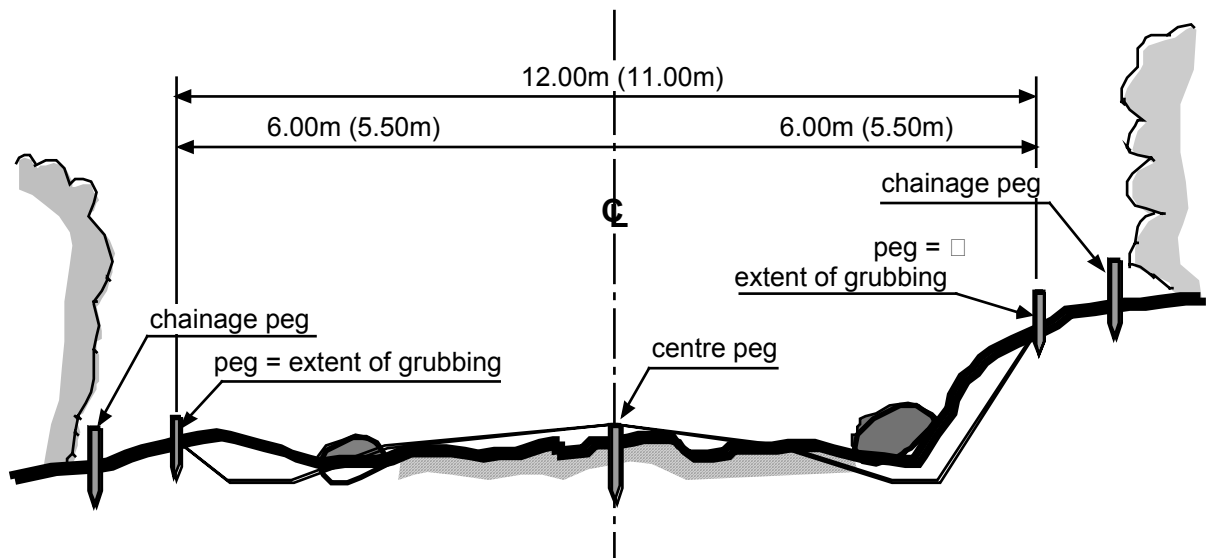

NOTE: □
 □ dimensions refer to cross section A1 and in brackets to A2 □

Labour:
 1 Gang Leader
 Labourers, according to day task

Tools and Equipment:

- Bush knives
- Hoes
- Shovels
- Rakes
- Wheelbarrows

Material:

- Strings
- Pegs

Suggested Productivity Range:
 Clearing (grass cutting, stripping and grubbing)
 = 100 – 200 m² / day / labourer

Actual Productivity:

Activity Sheet C4 TREE AND STUMP REMOVAL (Clearing)

Work Method:

- Set out width of area to be cleared using pegs and strings (same as for bush clearing).
- Define quantity of work for the day and allocate labourers accordingly.
- Cut tress. Fix ropes to ensure controlled felling. TAKE CARE TO AVOID INJURIES!
- Excavate around roots, cut stump and roots into pieces and remove.
- Dispose cut wood outside the cleared area while timber may be used by villagers. Some timber may also be used for scour checks and setting out pegs or for firewood.

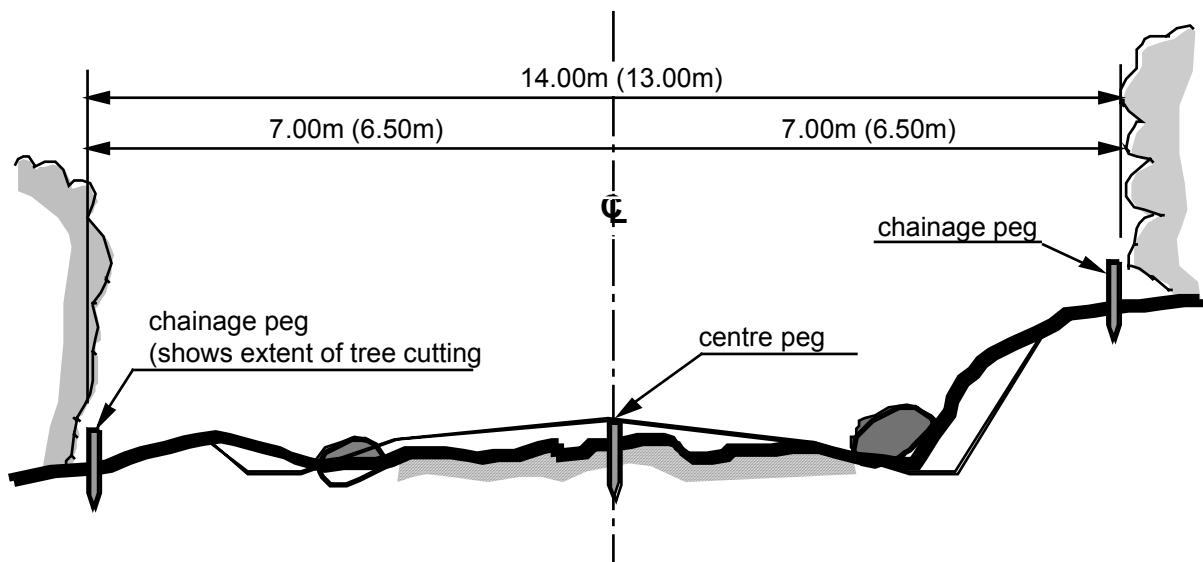

NOTE:

- disposal of cut wood outside the marked strip for bush clearing, preferably on lower side of road
- dimensions refer to cross section A1 and in brackets to A2

Labour:

1 Gang Leader
Labourers, according to day task

Tools and Equipment:

- Bow saws or two-men crosscut saw or chain saw
- Axes
- Mattocks
- Hoes and shovels
- Shovels
- Crowbars
- Ropes
- Wheelbarrows

Material:

- Strings
- Pegs

Suggested Productivity Range:

Tree and stump removal
= 150 – 250 m² / day / labourer
(or day work if work proves to be difficult)

Actual Productivity:

Activity Sheet C5 BOULDER REMOVAL (Clearing)

Work Method:

- Set out width of area to be cleared using pegs and strings (same as for grubbing).
- Define quantity of work for the day and allocate labourers accordingly.
- Remove boulders which are not bigger than 0.5m³ and dispose of outside the cleared area.
- Bury boulders which are bigger than 0.5m³ well below the formation.
- Bigger boulder is split using the fire and water method.
- Weathered rock is split using crowbars, chisels, sledgehammers or plugs and feathers.
- Larger boulders or rocky sections require blasting. This should only be done by experts and after having attained the necessary license and authority.
- Broken stones should be disposed outside the cleared area. Good stones may be selected and retained for structure works and/or scour checks or gabion works. Smaller pieces may also be retained for hardcore beds underneath foundations.

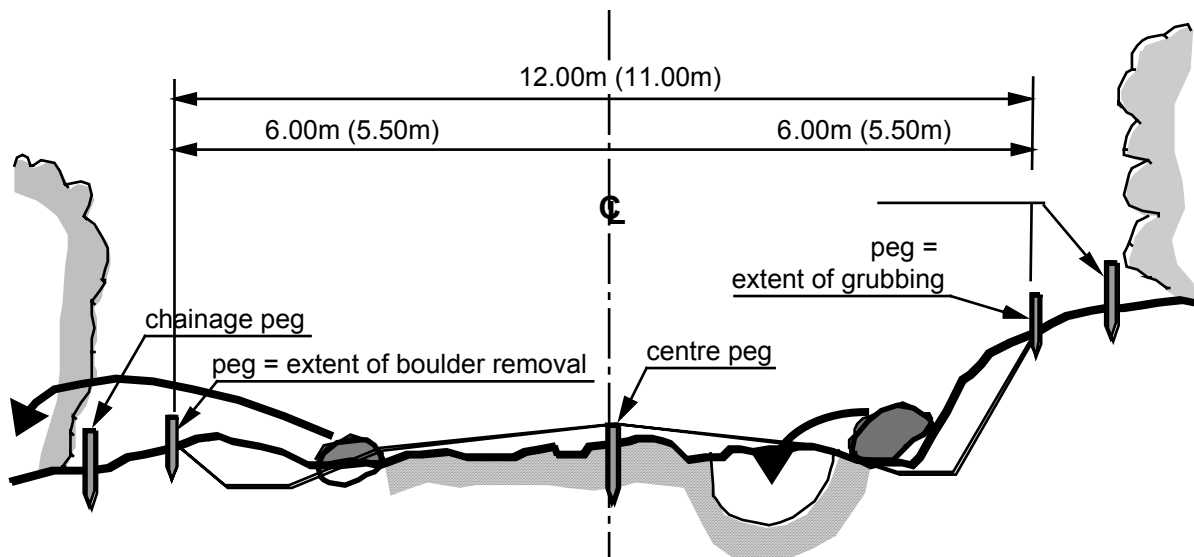

NOTE:
• dimensions refer to cross section A1 and in brackets to A2

Labour:
1 Gang Leader
Labourers, according to day task

Tools and Equipment:

- Chisels
- Feathers and plugs
- Sledge hammers + hammers
- Crowbars
- Pick Axes
- Shovels
- Ropes
- Wheelbarrows

Material:

- Strings
- Pegs
- Fire wood and water (for splitting)

Suggested Productivity Range:

- Boulder removal = 300 – 800 m² / day / labourer, if small boulders to bury or disposing
- Day work for rock breaking and larger boulders

Actual Productivity:

Activity Sheet

DEALING WITH ROCK

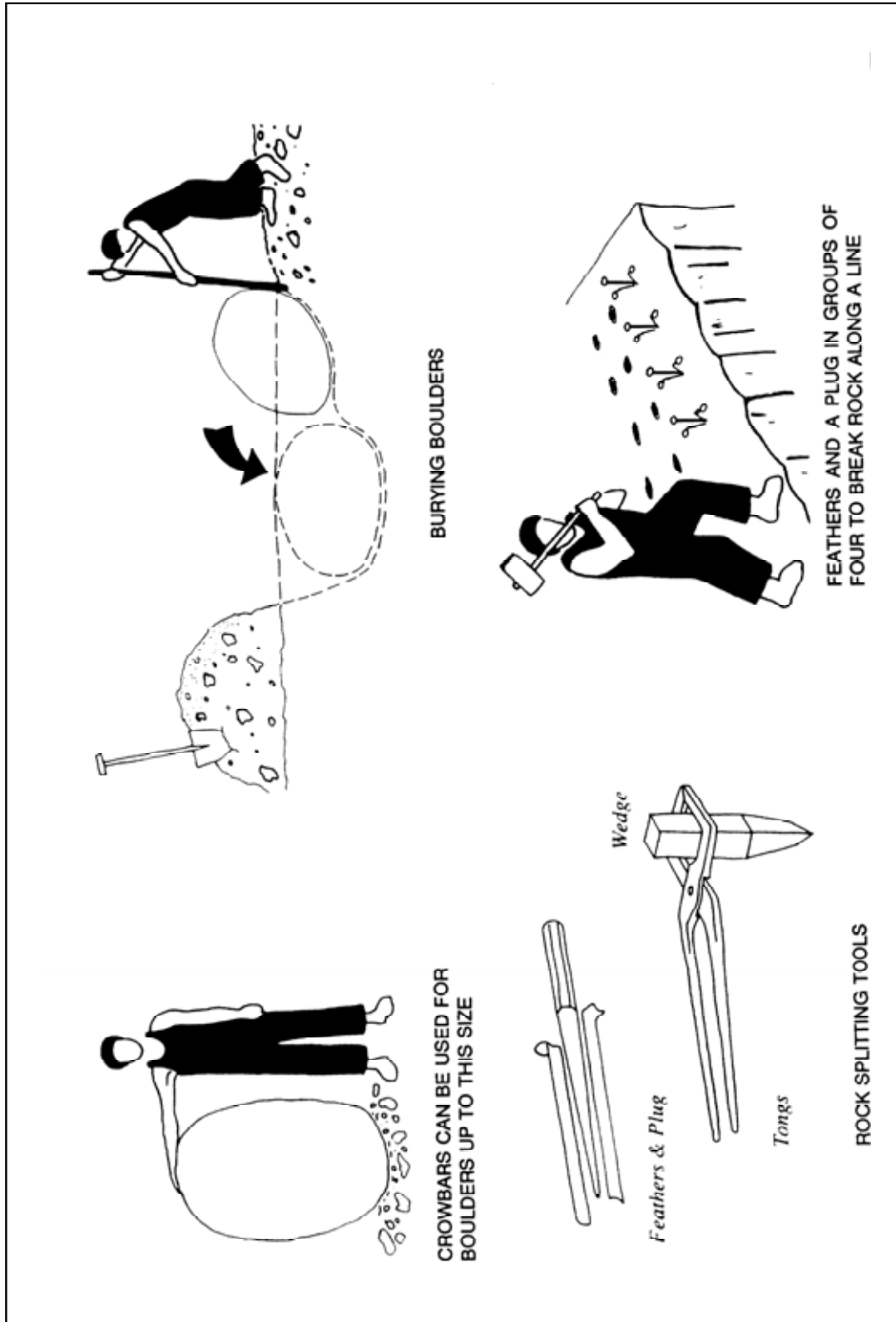

Ac

**SETTING OUT VERTICAL ALIGNMENT:
Slotting**

The slotting method is **adequate for most sections of road** where a reasonable vertical alignment exists. It usually allows earthworks to be balanced laterally and is suitable for the majority of situations on unpaved rural roads.

Work Method:

7. Set out a slot every ten meters in a right angle to the centre line. Each slot is 50cm wide. The length depends on the chosen cross-section and should extend from back of ditch to back of ditch (i.e. 9.90 metres on the Standard Cross Section A1).
8. If the slot is more than 0.5 metres high at any point, the sides of the slot excavation should be backsloped instead of vertical.
9. Compact the fill side of the slot using a hand rammer. Ensure with a straight edge and spirit level that the slot is exactly horizontal.
10. If the existing alignment is uneven the slots may vary considerably in alignment along the road. To overcome this, longitudinal balancing is carried out as a follow up operation to the initial slotting → for details see Activity Sheet 6B.

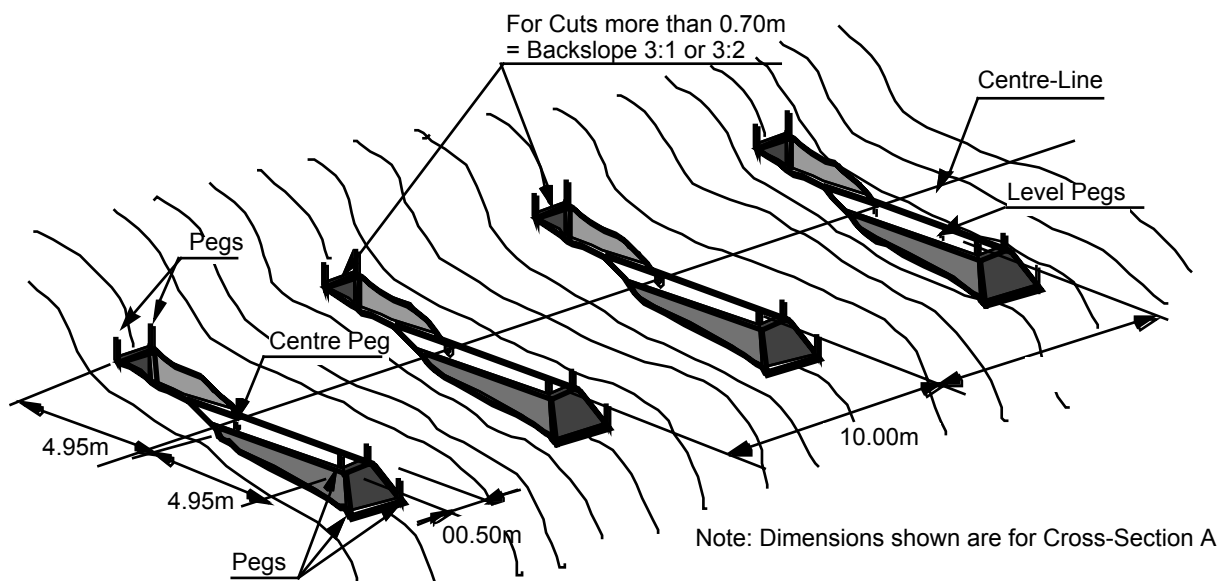

Labour:

1 Site Supervisor (part time)
1 Gang Leader
Labourers, according to day task

Tools and Equipment:

- 2m straight edge
- spirit level
- 3 boning rods
- Tape measure
- Hand rammer
- Mattock. Pick axe, hoe, shovel

Material:

- Strings
- Pegs

Suggested Productivity Range:

◆ Slotting = 3 – 4 No / day / labourer

Actual Productivity:

Activity Sheet **C6B**

**SETTING OUT VERTICAL ALIGNMENT:
Longitudinal Balancing**

If the existing alignment is uneven the slots may vary considerably in alignment along the road. To overcome this, longitudinal balancing is carried out as a follow-up operation to the initial slotting.

Work Method:

<p>Case 1</p>	<p>Slot B is lower by more than 10cm from the uniform gradient slot A to slot C. The level of slot B is raised by borrowing material from slot A and slot C until "d" is less than 10cm.</p>
<p>Case 2</p>	<p>Slot B is higher by more than 10cm from the uniform gradient slot A to slot C. The level of slot B is lowered by transporting material to slot A and slot C until "d" is less than 10cm.</p>
<p>Case 3</p>	<p>"d" is less than 10cm; no longitudinal balancing is needed.</p>

Labour:
 1 Site Supervisor (part time)
 1 Gang Leader
 1 Labourer to support

Tools and Equipment:

- 3 boning rods
- Tape measure
- hoe, shovel

Material:

Suggested Productivity Range:

- Part of slotting task

Actual Productivity:

Activity Sheet **C6C**

**SETTING OUT VERTICAL ALIGNMENT:
Terracing**

- The terracing method is suitable in **flat terrain without substantial earthwork quantities** and should not be used if cuts are higher than 0.25 metres or if the existing road formation is rutted with deeply eroded gullies.
- The terracing method balances the lateral earthworks within a material throwing distance of less than 20 metres. Road centrelines and formation width are set out at intervals of 10 metres to indicate the extent to be excavated by the labourers using pegs and strings.
- The terracing method does not involve any establishment or setting out of levels prior to the commencement of the excavation works.
- Guidance on the vertical road alignment entirely depends on visual control during construction and a final work approval.

Work Method:

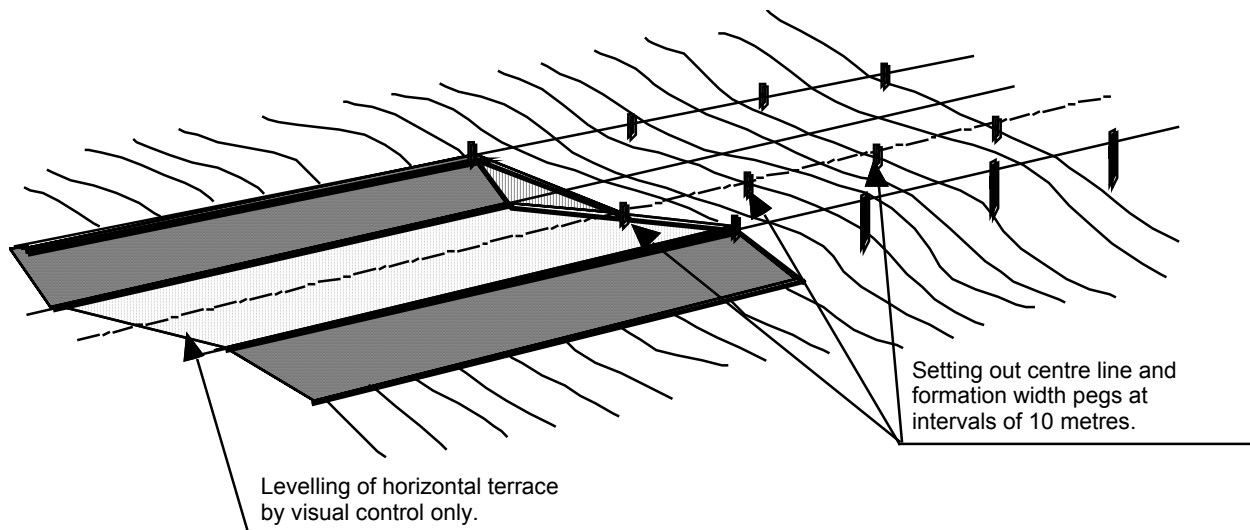

Labour:
 1 Site Supervisor (part time)
 1 Gang Leader
 1 Labourer, to assist

Tools and Equipment:
 • 2m straight edge, or longer
 • spirit level
 • 3 boning rods
 • Tape measure, 5m and 30m

Material:
 • Strings
 • Pegs

Suggested Productivity Range:
 • Daywork

Actual Productivity:

Activity Sheet **C6D**

**SETTING OUT VERTICAL ALIGNMENT:
Profile**

The profile method enables the vertical alignment of the road to consist of straight gradients connected with fairly smooth vertical curves.

Work Method:

- The first operation in the profile method is to construct a slot at each 10-metre centreline peg as described under the first stage of the slotting method. This allows a first approximation of the vertical alignment. The slots are not adjusted at this stage. To refine the alignment the following steps are taken:
- Choose setting out sections of approximately 60 to 100m, which have either more or less the same gradient of vertical curve.
- Setting out a gradients:

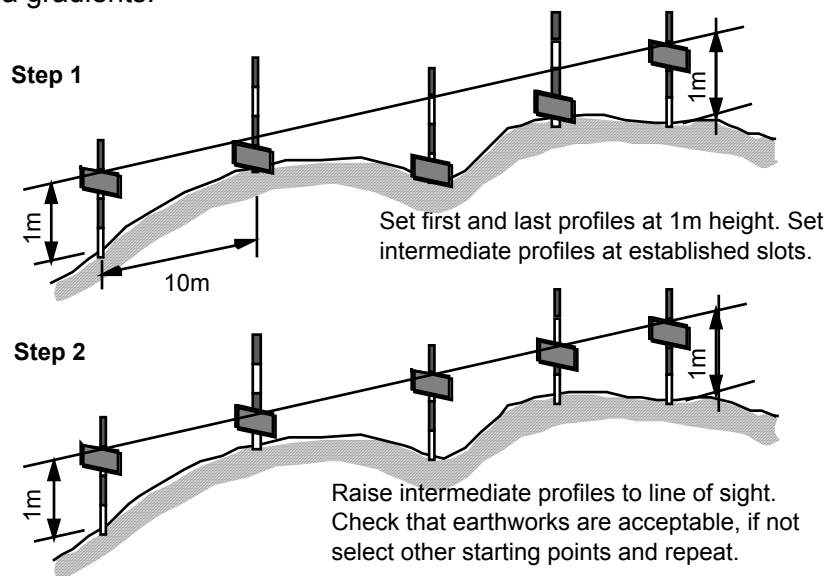

- Setting out a vertical curve:

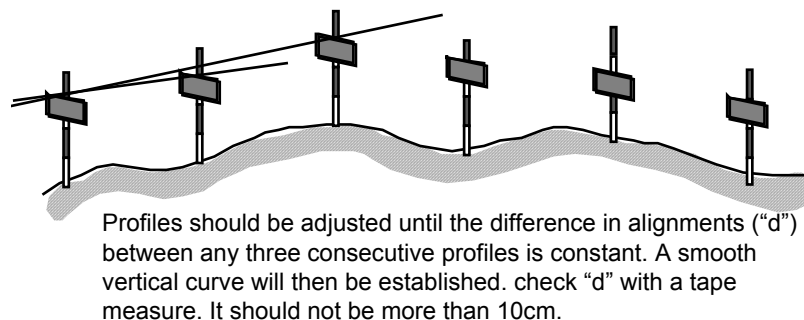

Labour:
 1 Site Supervisor (part time)
 1 Gang Leader
 1 Labourer, to assist

Tools and Equipment:
 • 10 profile boards (ranging rods with sliding boards)
 • Tape measure, 5m and 30m

Material:
 • Strings
 • Pegs

Suggested Productivity Range:

- Daywork

Actual Productivity:

Activity Sheet C7 EXCAVATION TO LEVEL

Work Method:

- The slots act as a guideline for the excavation and filling of each 10-metre section of road to achieve a transversely level terrace.
- Define quantity of work for the day and allocate labourers accordingly. (Calculate volume of earthworks between two consecutive slots for individual tasks).
- Spread the fill material in thin layers (about 0.15m) and compact to a density as specified in the contract. The operation continues until a smooth terrace is achieved to the same levels as the slots.
- Check the level of the terrace with boning rods (or traveller if the profile method is used) and correct where necessary.
- Compact terrace to density specified in the contract document. Use pedestrian vibrating roller or tractor towed dead weight roller. Ensure optimum moisture content of the soil when compacting!

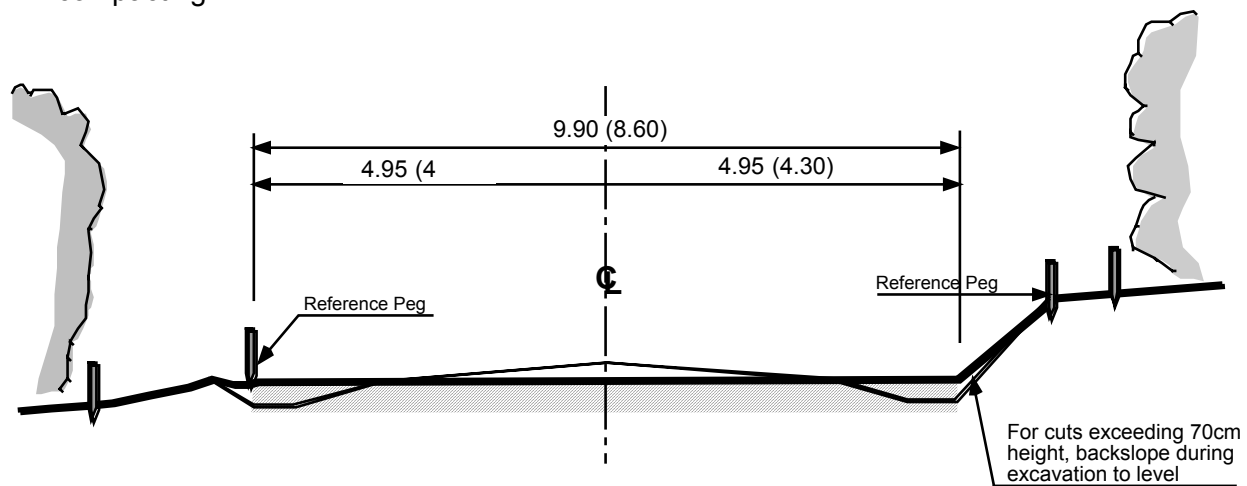

Note: On steep sidelong (steep slope) ground there is a danger of fill material slipping down the slope. In these circumstances "benches" should be cut into the existing ground under the toe of the fill to help anchor it. (→ see benching on Activity Sheet C1)

<p>Labour: 1 Gang Leader Labourers</p>	<p>Tools and Equipment:</p> <ul style="list-style-type: none"> • Pick axes • Mattocks • Hoes • Shovels • Rakes or Spreaders • Wheelbarrows • Straight edge, 2m or longer • Spirit level • Boning Rod Set • Pedestrian vibrating roller or tractor towed dead weight roller 	<p>Material:</p> <ul style="list-style-type: none"> • Strings • Pegs
---	---	---

<p>Suggested Productivity Range: Excavation to level = 3 - 4 m³ / day / labourer</p>	<p>Actual Productivity:</p>
--	------------------------------------

Activity Sheet **C8** *DITCHING*

Work Method:

- Set out the width of the ditches on both sides using pegs and strings. Establish the material pegs and show edge of fill in the middle with strings. (See dimensions below).
- Define quantity of work for the day and allocate labourers accordingly.
- Excavate the ditches for the correct size. Use the ditch template to control width and depth. Throw the excavated material to the middle in between the material pegs.
- Spread and level the material in the middle.
- Compact middle layer with pedestrian vibrating roller or tractor towed death weight roller.

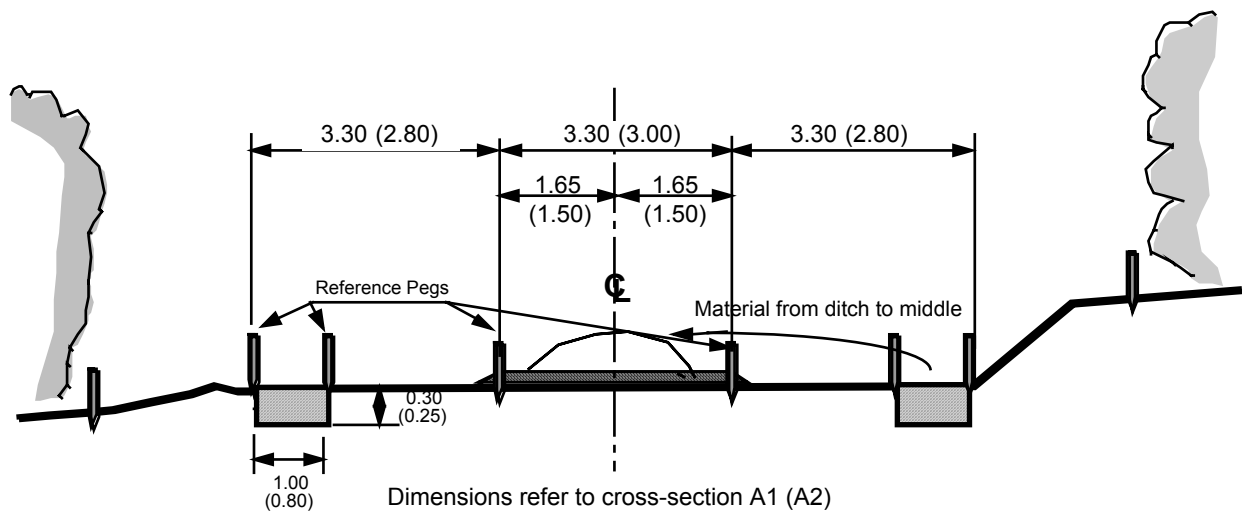

Labour:
1 Gang Leader
Labourers

Tools and Equipment:

- Pick axes
- Mattocks
- Hoes
- Shovels
- Rakes or Spreaders
- Ditch templates
- Straight edge, 2m or longer
- Pedestrian vibrating roller or tractor towed dead weight roller

Material:

- Strings
- Pegs

Suggested Productivity Range:
Ditching = 2 – 3.5 m³ / day / labourer

Actual Productivity:

Activity Sheet **C9** **BACKSLOPING**

Work Method:

- Set out the outer side of the backslope using pegs and strings. Establish the material pegs again and show edge of fill in the middle with strings. (See dimensions below).
- Define quantity of work for the day and allocate labourers accordingly.
- Cut the slopes to the correct shape. Use the slope template to control width and slope.
- Throw the excavated material to the middle in between the material pegs.

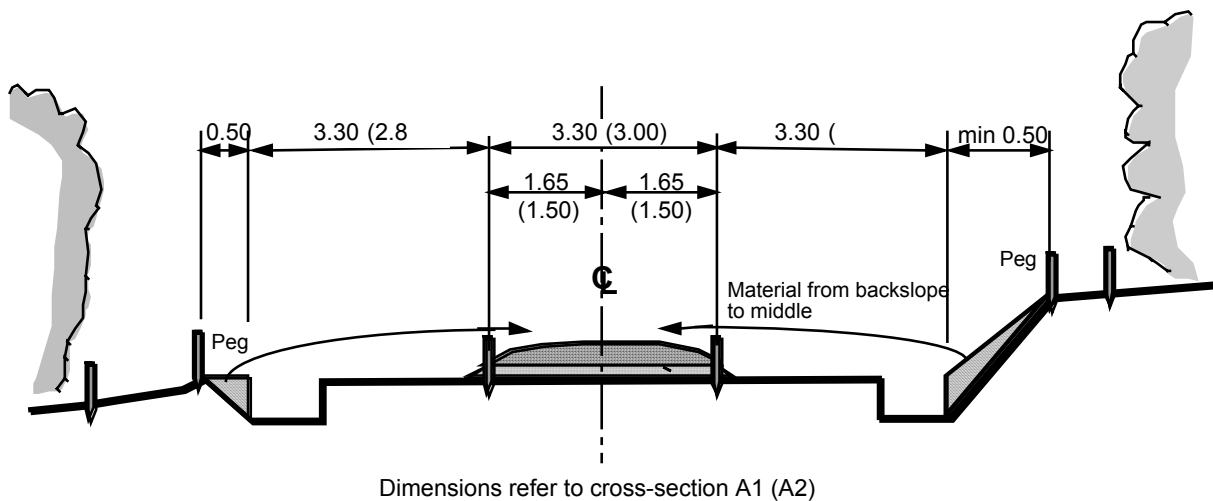

Labour:
1 Gang Leader
Labourers

Tools and Equipment:

- Pick axes
- Mattocks
- Hoes
- Shovels
- Rakes or Spreaders
- Slope templates and spirit level
- Straight edge, 2m or longer
- Pedestrian vibrating roller or tractor towed dead weight roller

Material:

- Strings
- Pegs

Suggested Productivity Range:
Backsloping = 2.5 – 4.0 m³ / day / labourer

Actual Productivity:

Activity Sheet C10 SLOPING

Work Method:

- Set out the shoulder break-point line using pegs and strings. Establish the material pegs again and show edge of fill in the middle with strings. (See dimensions below).
- Define quantity of work for the day and allocate labourers accordingly.
- Cut the slopes to the correct shape. Use the ditch-slope template to control the slope.
- Throw the excavated material to the middle in between the material pegs.

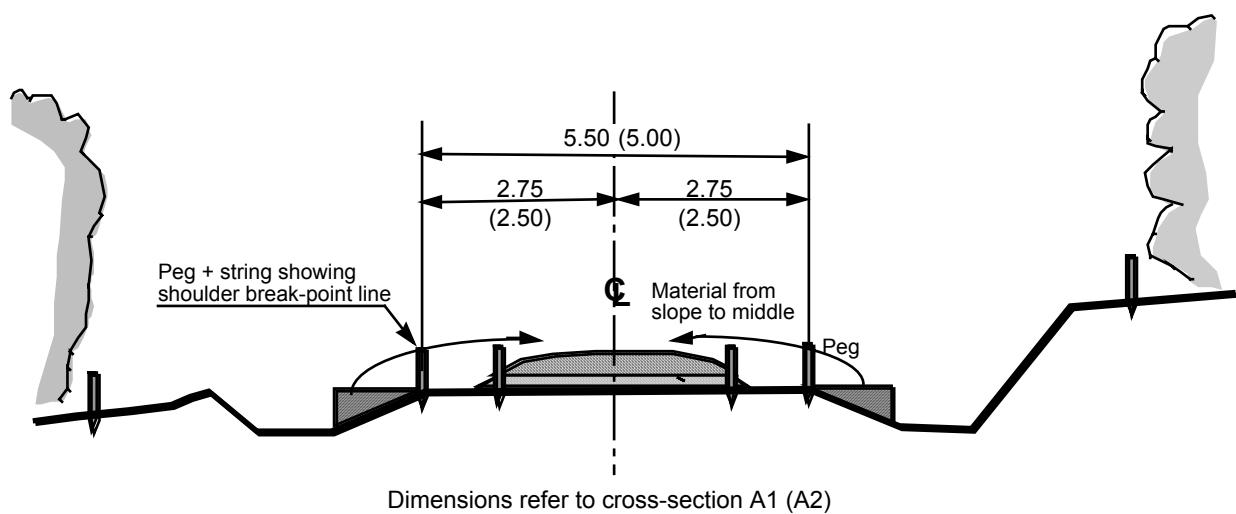

Labour:
1 Gang Leader
Labourers

Tools and Equipment:

- Pick axes
- Mattocks
- Hoes
- Shovels
- Rakes or Spreaders
- Ditch-Slope templates and spirit level

Material:

- Strings
- Pegs

Suggested Productivity Range:
Sloping = 2.5 – 4.0 m³ / day / labourer

Actual Productivity:

Activity Sheet C11 CAMBER FORMATION

Work Method:

- Set out the shoulder break-point line using pegs and strings. Re-establish the centre line using pegs. (See dimensions below).
- Define quantity of work for the day and allocate labourers accordingly.
- Spread the material that has been heaped in the middle towards the edge (shoulder break point).
- Form the camber by ensuring that the crossfall from the middle to the edge is about 8% to 10%. Check with the camber board and spirit level. (The material will later settle during compaction and over time and the original “roof” shape will be rounded).
- Compact the spread material with a pedestrian vibrating roller or tractor towed death weight roller. Ensure an even surface. Reshape where necessary or fill depressions with additional material from the backslope.

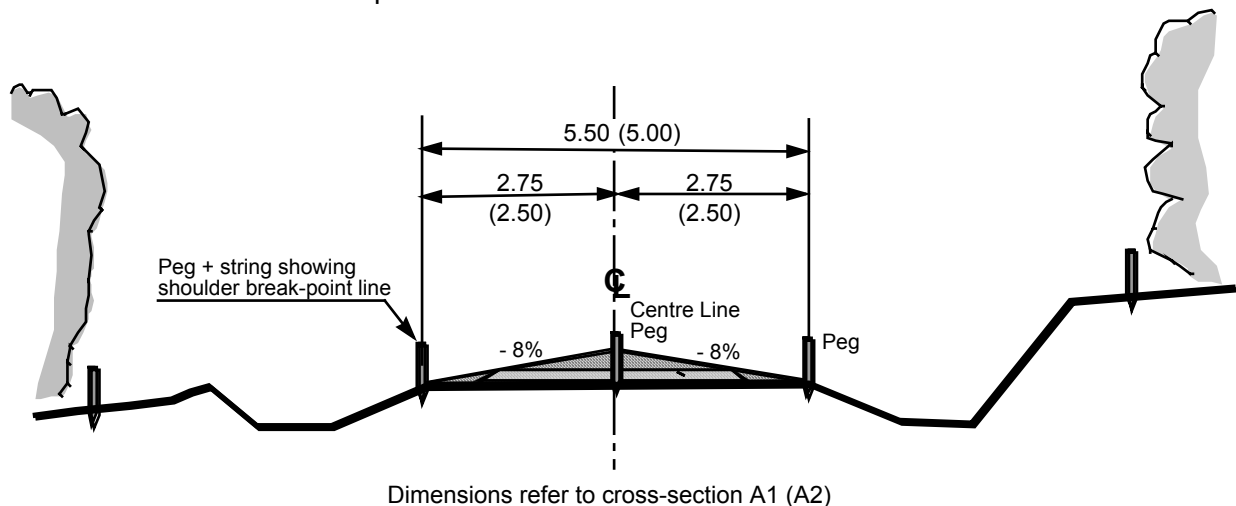

Labour:
1 Gang Leader
Labourers

Tools and Equipment:

- Hoes
- Shovels
- Rakes or Spreaders
- Camber board and spirit level
- Wheelbarrows
- Pedestrian vibrating roller or tractor towed dead weight roller

Material:

- Strings
- Pegs

Suggested Productivity Range:
Camber formation = 100 – 200 m² / day / labourer

Actual Productivity:

Activity Sheet **C12** **MITRE DRAINS**

Work Method:

- Set out the mitre drain as per the drawing below. Wherever possible they should be constructed at intervals of 20 metres along the road alignment. Ensure that the gradient of the mitre drain equals the gradient of the side drain or it not less than 2%. Identify mitre drain locations before ditching in order to spare “blocks” from being excavated.
- Define quantity of work for the day and allocate labourers accordingly.
- Excavate mitre drain. Ensure backslopes on both sides. Use excavated material as blockage on the inner side of the mitre drain.
- Where the gradient of the mitre drain is more than 4% scours checks might be required.

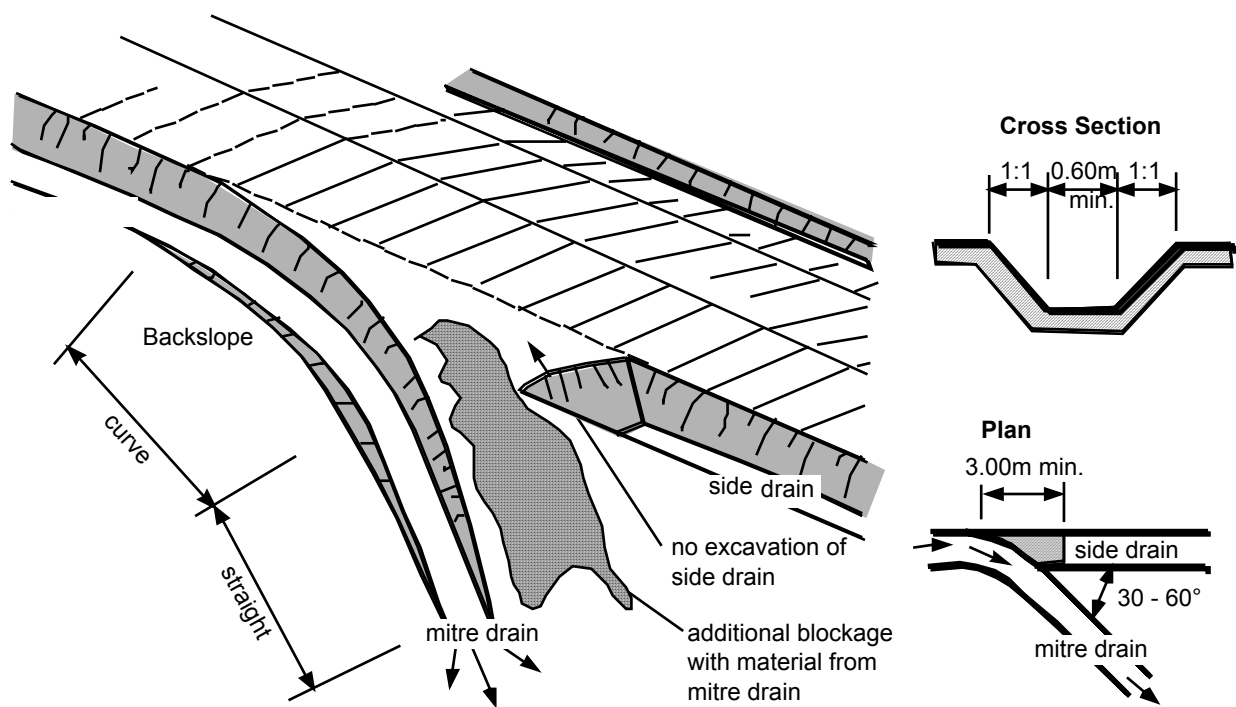

Labour:
1 Gang Leader
Labourers

Tools and Equipment:

- Hoes
- Pickaxes
- Mattocks
- Shovels

Material:

- Strings
- Pegs

Suggested Productivity Range:
Mitre drain = 2.0 – 3.5 m³ / day / labourer

Actual Productivity:

Activity Sheet **C13** **CATCH WATER DRAINS**

Work Method:

- Catch water drains are usually required in hilly or mountainous terrain where there is a lot of surface water. This needs to be collected and safely led away before it reaches the excavated slope on the hillside. Where catch water drains have to be located outside the road reserve cooperation with the landowners has to be sought.
- Set out the catch water drain using pegs and strings. Ensure gradient of min. 2% but not steeper than 4%. The drain should not be too close to the cut face (see drawing below). The drain should be minimum 60cm wide and at the valley side 40cm deep.
- Define quantity of work for the day and allocate labourers accordingly.
- Excavate the drain with slopes of min. 3:1. Heap the excavated material below the drain and compact slightly with hand rammer. Plant grass or fast growing bushes to consolidate and retain the material of the block.
- Where the gradient of the drain is more than 4% construct scour checks for erosion control.

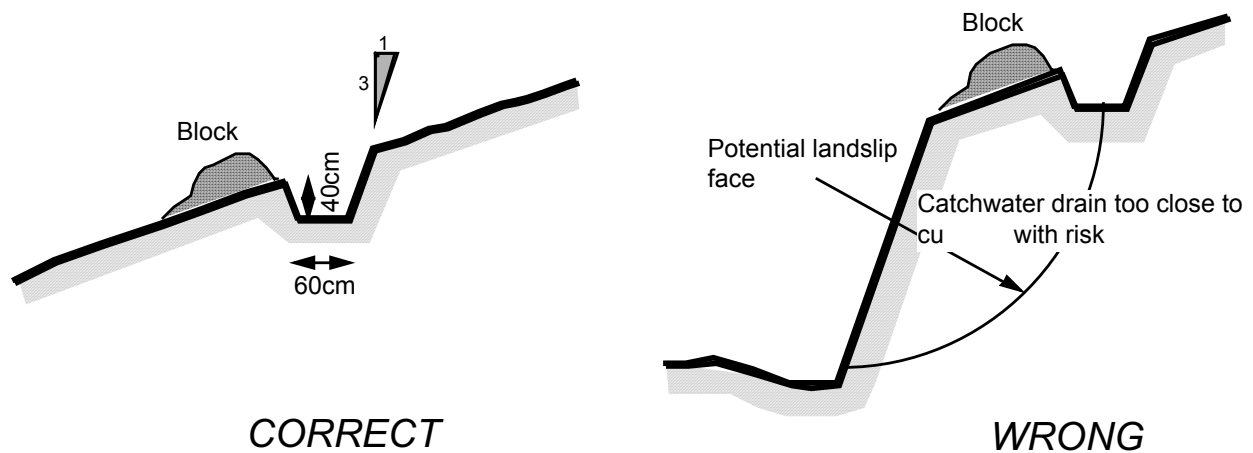

Labour:
1 Gang Leader
Labourers

Tools and Equipment:

- Hoes
- Pickaxes
- Mattocks
- Shovels

Material:

- Strings
- Pegs

Suggested Productivity Range:
Catch water drain = 2.0 – 3.5 m³ / day / labourer

Actual Productivity:

Activity Sheet **C14** **SCOUR CHECKS**

Scour checks are required to **reduce the speed of the water** flowing in the ditch so **that no erosion** can take place. Usually for gradients below 4% no scour checks are required.

Work Method:

- Define locations for scour checks as per the table below. Mark locations with pegs.
- Define quantity of work for the day and allocate labourers accordingly.
- Construct as per the following drawing (using wooden pegs → follow the same principles when using stones. Use ditch slope template with scour check lath.

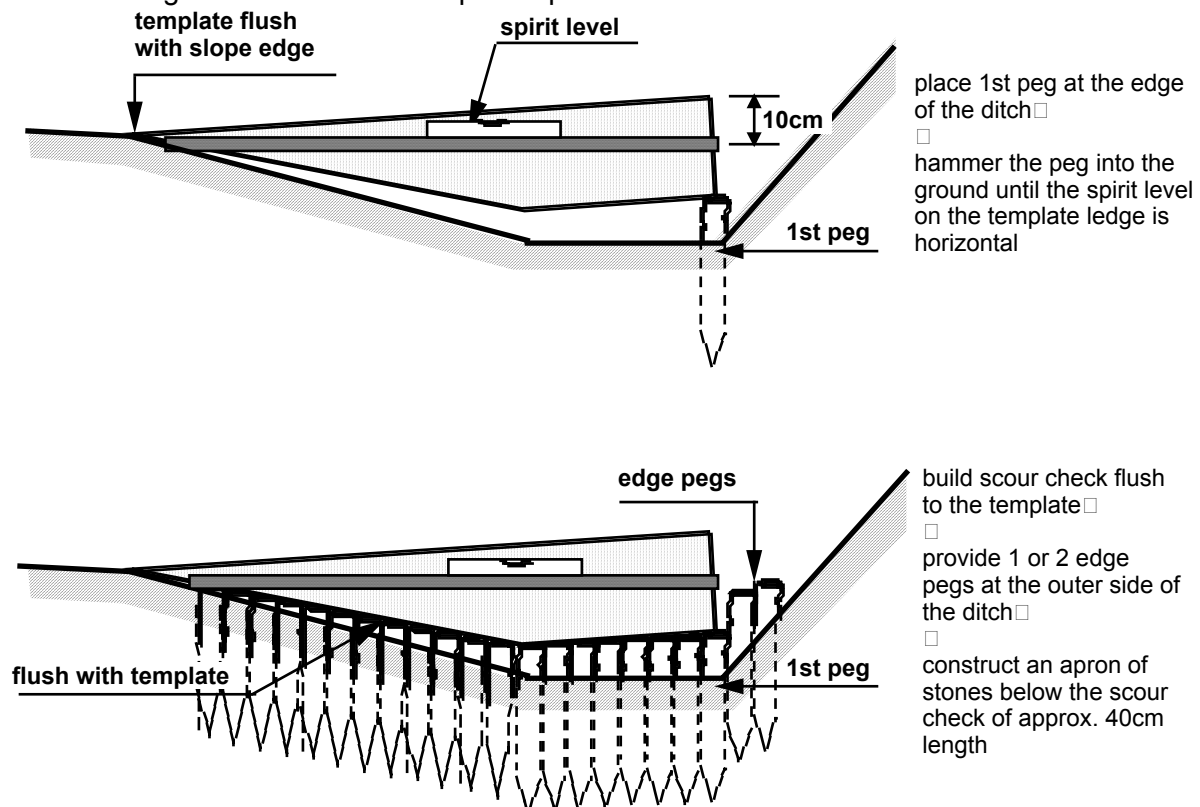

GRADIENT OF ROAD	SCOUR CHECK SPACING ACCORDING TO SOIL CONDITIONS		GRADIENT OF ROAD	SCOUR CHECK SPACING ACCORDING TO SOIL CONDITIONS	
	GOOD	POOR		GOOD	POOR
2%	None	None	8%	7.5m	4m
3%	None	20m	9%	6m	3m
4%	None	15m	10%	5m	2.5m
5%	20m	10m	12%	4m	Lining with masonry
6%	15m	7.5m	15%	Lining with masonry	Lining with masonry
7%	10m	5m			

Labour:
1 Gang Leader
Labourers

Tools and Equipment:

- Ditch and slope template with spirit level
- Hammer
- Bush knife

Material:

- Strong pegs, or
- Stones

Suggested Productivity Range:
Scour checks = 2 – 4 No. / day / labourer

Actual Productivity:

E.7 QUALITY CONTROL FOR EARTH ROAD WORKS

ROAD DIMENSION TESTS				
(i) Type of tests: Simple checks on the dimensional accuracy of the construction works.				
(ii) Methods used: Tapes and/or templates are used to measure the completed works.				
Test	Method	Location	(every ..)	Tolerance
Width of carriage way sub-base terrace (excavation to level)	tape	field	100m	+/- 50mm
Width and depth of side drains	template	field	10m	+/- 20mm

ROAD PROFILE TESTS				
(i) Type of tests: Checks on the camber and longitudinal profile of the carriageway.				
(ii) Methods used: Camber boards, boning rods and/or levelling instrument are used to measure the completed base and surface layer.				
Test	Method	Location	Test Interval (every ..)	Tolerance
Camber	template	field	20m	+/- 10mm
Longitudinal profile	boning rods	field	20m	+/- 50mm

E.8 CULVERTS



- For details on culvert design and construction refer to the **Culvert Manual, An Introduction to Hydraulics, Design and Construction (MOWS)**, and to the **Technical Manual for Labour Based Road Rehabilitation (MOWS)**, Chapters H-3 and H-4.
- For details on masonry work refer to **Module H**.

E.8.1 Definitions

- A relief culvert, or cross drainage structure, is an integrated part of the road drainage system, and conveys water from the upper (uphill) side of the road to the lower (downhill) side. It discharges runoff during and after rainfall from the road surface and adjacent roadside areas. Relief culverts carry water seasonally only.

- A stream culvert, or cross drainage structure, is required at the intersection point between an existing watercourse and the road alignment. The volume of water to be discharged through the crossing includes the flood carried by the stream or river and the runoff from the road drainage system. Flood levels will be largest after heavy rains, but a minimum flow can normally be expected throughout the year.

Typical Culvert Features

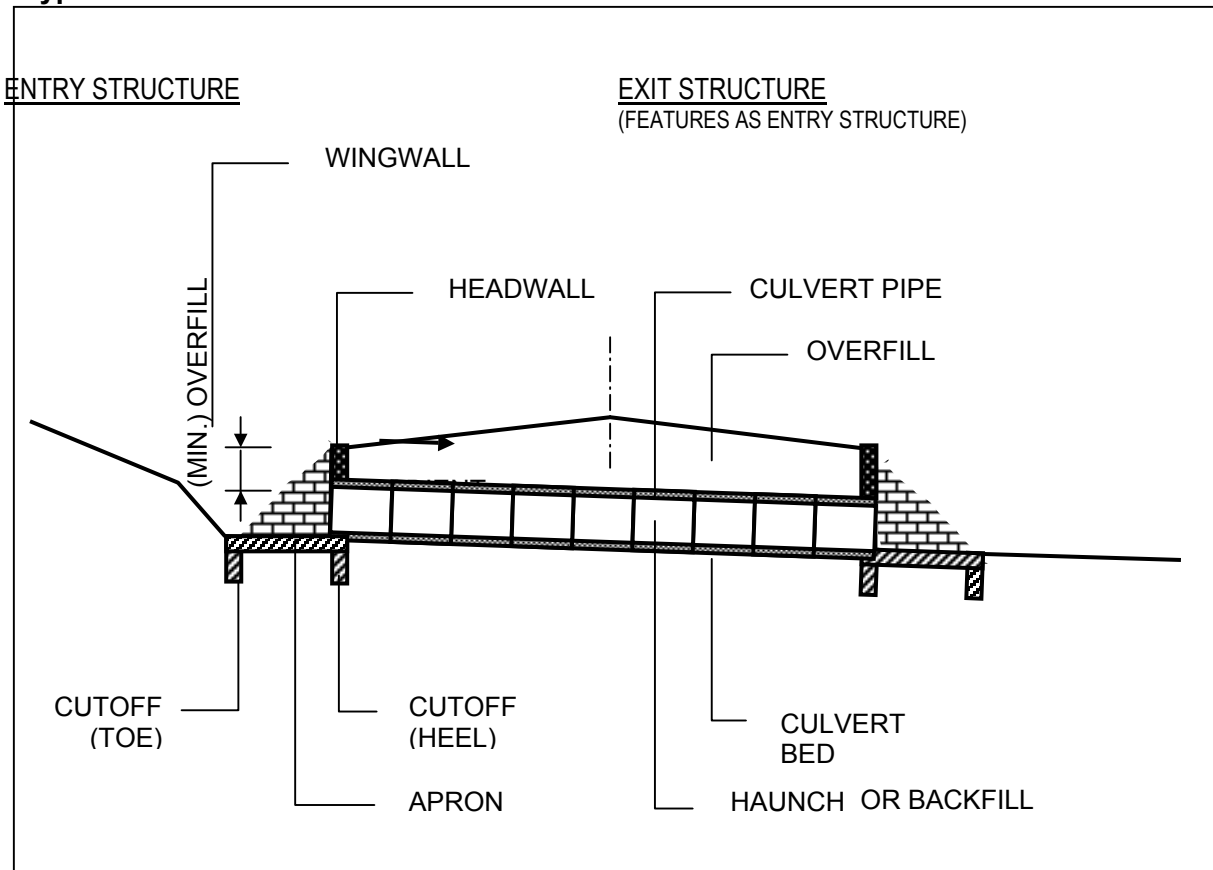

E.8.2 Manufacturing Culverts

The rings are cast locally using steel moulds. No reinforcement is used. The common pipe length for each ring is normally between 0.90 and 1.20m. The most commonly used size is the 0.60m Ø (24") pipe, although 0.90m Ø (36") are applied on some watercourses and multiple barrel situations.



- For details on concrete technology refer to Module G.
- For details on culvert production refer to Module I.

E.8.3 Setting Out

- Relief culverts or cross drainage structures are placed perpendicular to the (horizontal) road alignment. Stream culverts must be set out in the direction causing the lowest possible disruption to the natural flow of the watercourse.

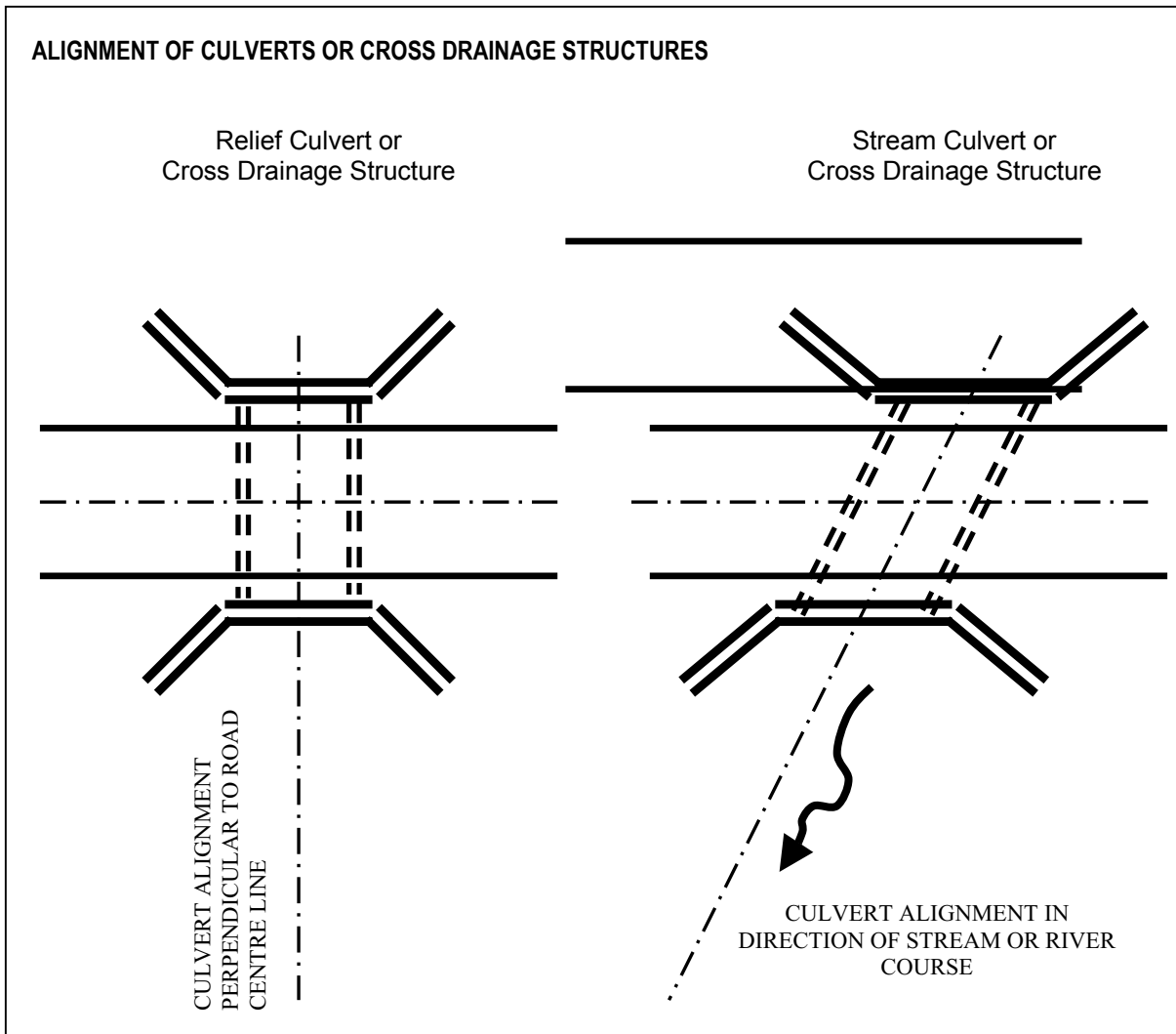

Procedures For Setting Out 0.60 M Ø Culvert in Undulating Terrain										
PROCEDURE STEP BY STEP	EXAMPLE/EXPLANATION									
<p><u>STEP 1</u></p> <p>Establish two pegs (peg A and peg B) at both road edges of the completed formation. Make sure that pegs are on the same level (use line and level or Abney level).</p>										
<p><u>STEP 2</u></p> <p>Measure distance between peg A and peg B (usually 5.50m for cross section A1 and 5.00m for A2)</p>										
<p><u>STEP 3</u></p> <p>Calculate the depth to be excavated at the inlet to ensure adequate cover (peg A).</p>	<table> <tr> <td>Outside diameter Of culvert pipe</td> <td>Ø 600mm</td> <td>0.72m</td> </tr> <tr> <td>Overfill</td> <td></td> <td>+0.45m</td> </tr> <tr> <td>Total depth</td> <td></td> <td>=1.17m</td> </tr> </table>	Outside diameter Of culvert pipe	Ø 600mm	0.72m	Overfill		+0.45m	Total depth		=1.17m
Outside diameter Of culvert pipe	Ø 600mm	0.72m								
Overfill		+0.45m								
Total depth		=1.17m								
<p><u>STEP 4</u></p> <p>Calculate the difference in level between peg A and B with the chosen gradient. 4% is normally selected as the ideal gradient in these terrain conditions.</p>	<table> <tr> <td>Gradient</td> <td>4%</td> </tr> <tr> <td>Difference in level:</td> <td></td> </tr> <tr> <td></td> <td>$\frac{4\% \times 5.50m}{100\%}$</td> </tr> <tr> <td></td> <td>=0.22m</td> </tr> </table>	Gradient	4%	Difference in level:			$\frac{4\% \times 5.50m}{100\%}$		=0.22m	
Gradient	4%									
Difference in level:										
	$\frac{4\% \times 5.50m}{100\%}$									
	=0.22m									
<p><u>STEP 5</u></p> <p>Calculate the depth to be excavated at the outlet (peg B).</p>	<table> <tr> <td>Inlet depth</td> <td>1.17m</td> </tr> <tr> <td>Difference in level:</td> <td>+0.22m</td> </tr> <tr> <td>Depth at outlet</td> <td>=1.39m</td> </tr> </table>	Inlet depth	1.17m	Difference in level:	+0.22m	Depth at outlet	=1.39m			
Inlet depth	1.17m									
Difference in level:	+0.22m									
Depth at outlet	=1.39m									

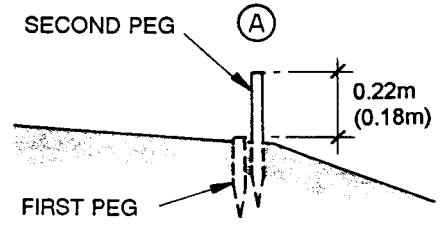
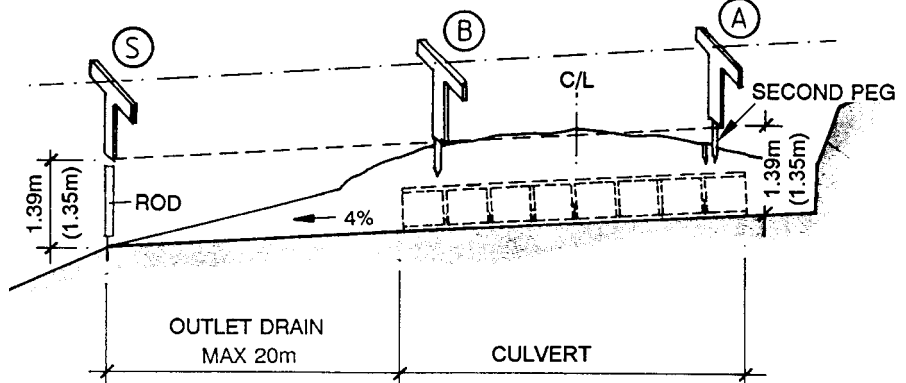
Procedures for Setting Out 0.60 M Ø Culvert in Undulating Terrain, Continued	
PROCEDURE STEP BY STEP	EXAMPLE/EXPLANATION
<p><u>STEP 6</u></p> <p>Raise level peg A by the same measurement that you have calculated under step 4 by establishing a second peg. (Difference in level).</p>	
<p><u>STEP 7</u></p> <p>Find the end of the outlet-drain by using boning rods and a stick or rod of length 1.39m. Walk the distance S away from B until the tops of A, B and S are in line.</p>	
<p><u>STEP 8</u></p> <p>Commence excavation of outlet drain starting from peg S and working towards peg A. Establish the excavation level for the culvert by measuring vertically down 1.39m from peg B and 1.17m from peg A.</p> <p>Note: In case the resulting outlet drain is longer than the maximum acceptable length, a detailed survey and design as described on page F 29 of the Technical Manual is required.</p>	

Procedures for Setting Out 0.60 M Ø Culvert in Flat Terrain	
PROCEDURE STEP BY STEP	EXAMPLE/EXPLANATION
<p>STEP 1 Based on levels obtained during the pre-construction survey, identify the end of the proposed outlet drain and place peg (1) flush to the existing terrain level. (Level ± 0.00)</p>	
<p>STEP 2 Set out inlet and outlet headwalls (begin and end of culvert line) and place pegs (2) and (3), flush to the existing terrain levels.</p>	
<p>STEP 3 Measure L, W and establish existing levels of pegs (2) and (3).</p>	<p>Example: L = 20.00 m; W = 8.50 m; Level (2) = +0.93; Level (3) = +1.11</p>
<p>STEP 4 Decide at which slope the outlet drain is to be excavated and culvert pipes are to be installed.</p>	<p>Example: Slope of outlet drain = 2% Slope of culvert pipes = 2%</p>
<p>STEP 5 Calculate invert level excavation depth at peg (2).</p>	<p>Example: Invert (2) = ±0 + = +0.40 Excavation(2) = 0.93–0.40 = 0.53m</p>
<p>STEP 6 Calculate invert level excavation depth at peg (3).</p>	<p>Example: Inv.(3)= +0.21 + = +0.61 Excavation(3) = 1.11–0.61 = 0.50m</p>



• In cases where the culvert has to be raised to allow water do drain, a ramp will have to be constructed over the culvert. How to construct such a ramp is detailed in the Technical Manual, Section H, Small Structures, Standard Relief Culvert H-4.

E.8.4 Culvert Bedding and Haunching

- Culverts must be bedded in stable material. Firm clay or sandy material is usually suitable. Wet, soft or organic material should be excavated and replaced with fine gravel, laterite, cement stabilised selected soil or concrete. Large stones could damage the culvert rings under loading and must not be allowed in contact with the rings and should be removed, or covered with suitable material. If necessary gravel containing stones up to 20mm or concrete may be used to bed the culvert rings.
- The culvert bed should be excavated to give continuous support over the lower third of the barrel. The shape of the bed should be controlled using a culvert template. The gradient should be controlled using boning rods and the established excavation pegs.

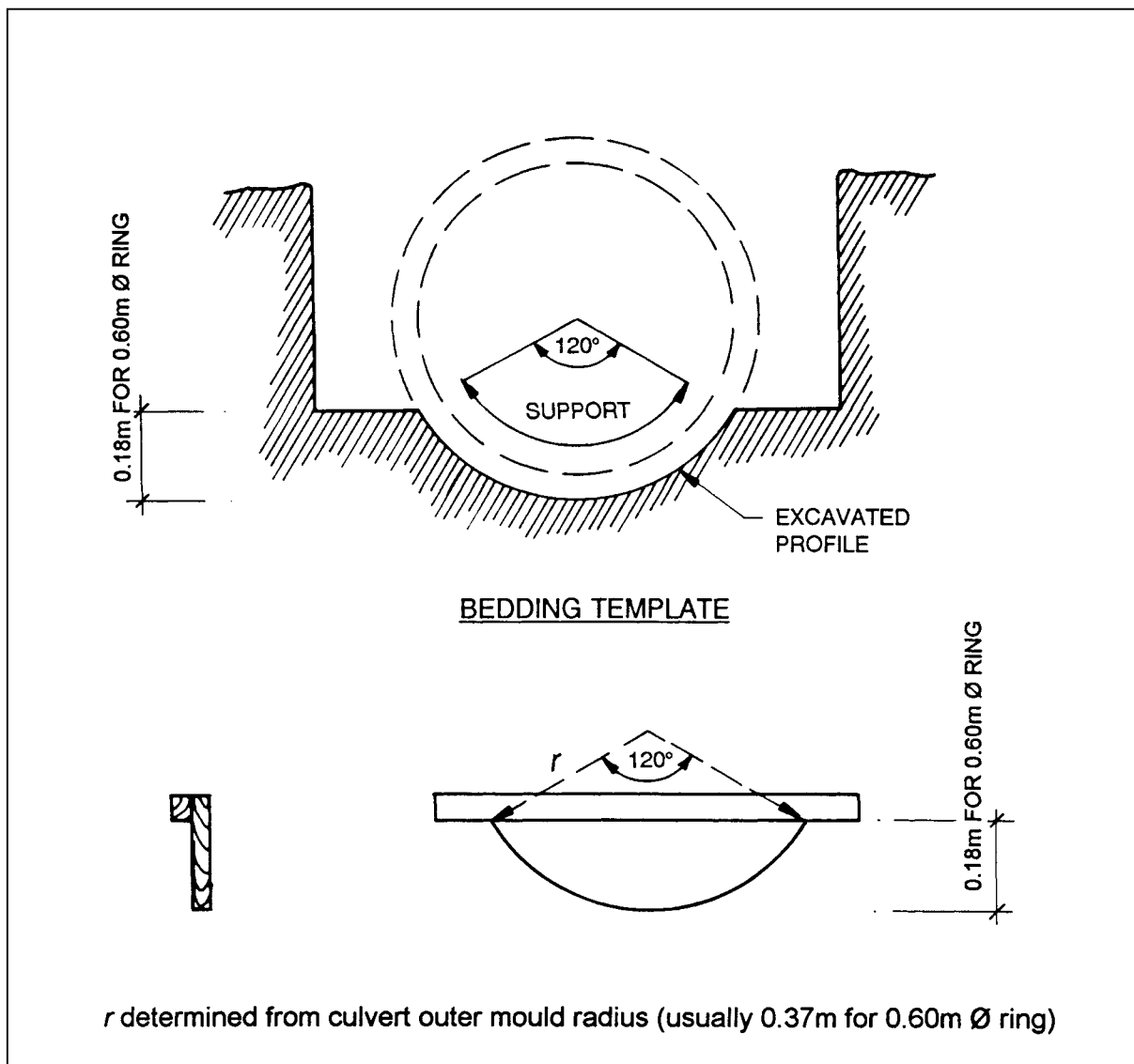

- Culvert overfill is usually determined in the drawings and specifications. If this should not be the case, the engineer should be requested to provide clear instructions.

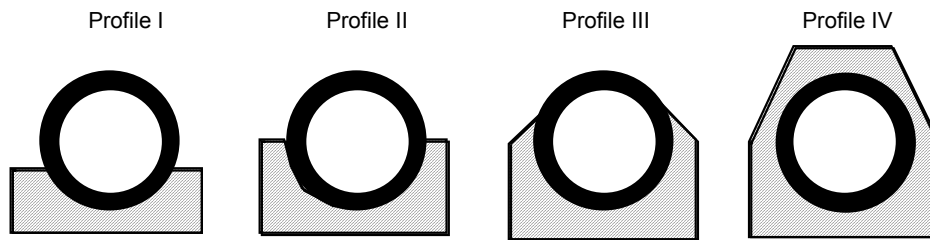
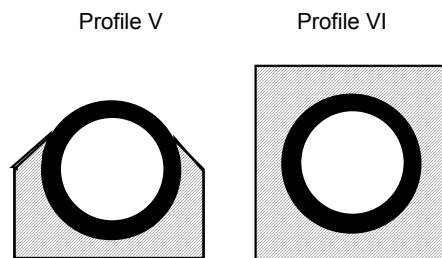
Pipe Bedding, Haunch and Surround Profile:**Concrete Cross Sections****Cement stabilised Laterite Cross Section**

- For details on concrete technology refer to **Module G**.
- For details on culvert production refer to **Module I**.

Important Notes for Working with Standard Relief Culverts Ø 60cm

- Particular attention must be given to location and levels of culverts to prevent erosion, siltation and long outfalls.
- In general culvert outfall drains should not exceed 20m length.
- Some locations require the road alignment to be raised to accommodate the culvert. The maximum ramp gradient should be 5%.
- Culvert rings should be well seated on a shaped bed (check with template and boning rods), or concrete bedded.
- Overfill must be at least 2/3 barrel diameter of well compacted material (0.45 m for 0.60 m Ø culvert) over the top of the culvert.
- Provision of haunching or full concrete surround is required if overfill is less than 2/3 barrel diameter.
- Provision of cement stabilised bedding, haunching or full concrete surround is required in poor insitu soil.
- Dry stone headwalls may be adequate for intermittent flows.
- Masonry, concrete or brick aprons are always required.
- Masonry/concrete/brick headwalls and outlet apron cutoffs are required for permanent water courses or high flows.
- All aprons should have cutoff walls, toe and heel, on both inlet and outlet sides.

E.9 SMALL STRUCTURE WORKS

E.9.1 Introduction

Small structures are common features on rural roads. They are usually designed to utilise the locally available materials and to be cost effective. Typical types of structures are; drifts, vented drifts, masonry arch culverts, multiple culverts, box culverts, and smaller bridges. Most of these structures are constructed using masonry or concrete components.



- For principles and details on concrete technology refer to Module G.
- For principle and details on masonry work refer to Module H.

This section provides you with general information on small structures and gabion works, as these are very common on rural roads.



- For further details on structures refer to the *Culvert Manual: An Introduction to Hydraulics, Design and Construction (MOWS)*, and to the *Technical Manual for Labour Based Road Rehabilitation (MOWS)*, Chapter H-5.
- Detailed drawings and specifications for structures are provided in the contract document. Contact the Engineer should they be unclear or incomplete. Ask for detailed instructions.

E.9.2 Common Structures for Rural Roads

Structures on rural roads usually have to be affordable and at the same time they should be durable and relatively maintenance free. Long-span bridges are therefore avoided which means that structures are “low-lying”. As much as possible locally available materials are used for construction, such as stones, sand, and timber.

Drifts are very common structures especially in areas where rivers are seasonal. In cases where a constant flow of water has to be accommodated, vented drifts (or Irish bridges) are built. Short-span bridges can be built as box-culverts or stone-arch culverts. Some principle features are provided in the following diagrams:

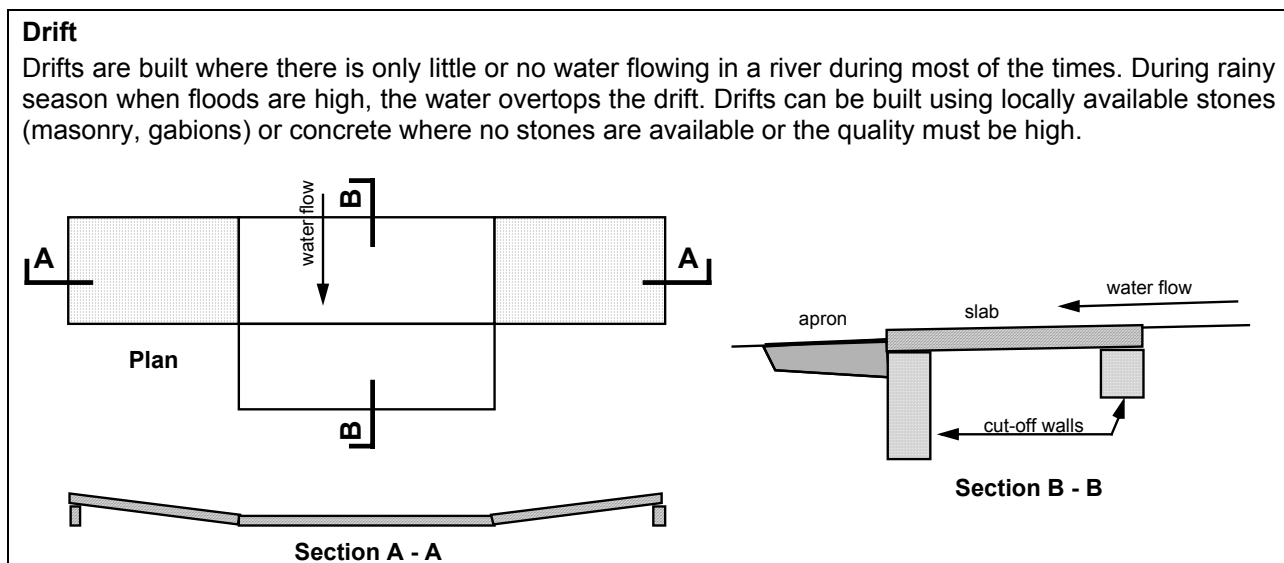

Vented Drift

The culvert pipes accommodate the normal water flow. During high floods the water is allowed to overtop the structure. In most cases the slab is made of concrete or masonry. The head walls are masonry while the culverts can be of concrete or steel (Armco). Also mini arches made of masonry are possible.

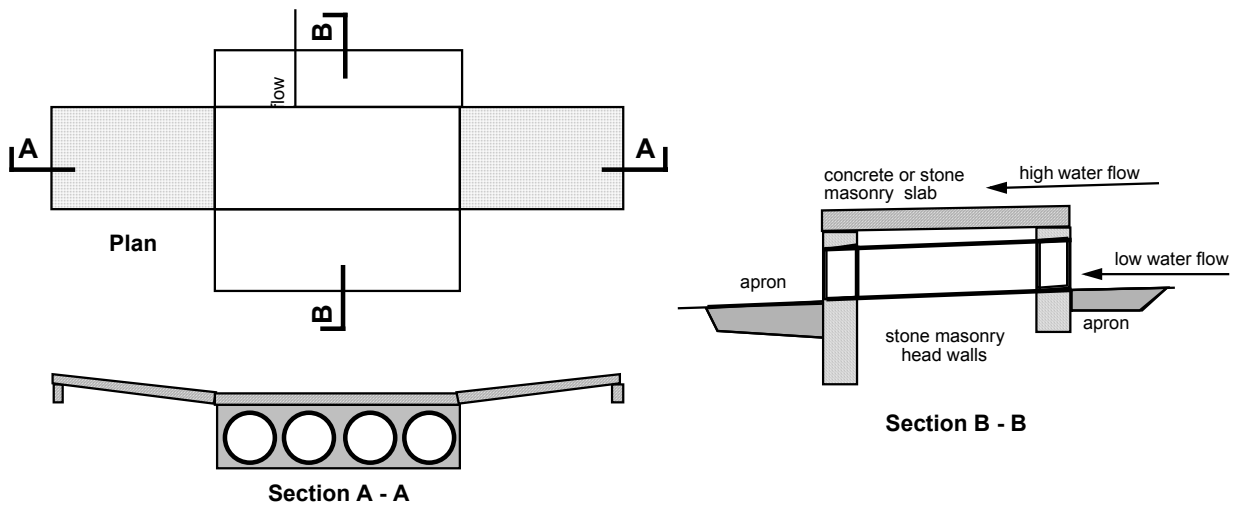

Box Culvert

The walls and the bottom slab of box culverts are usually made of masonry. The deck has to be reinforced concrete.

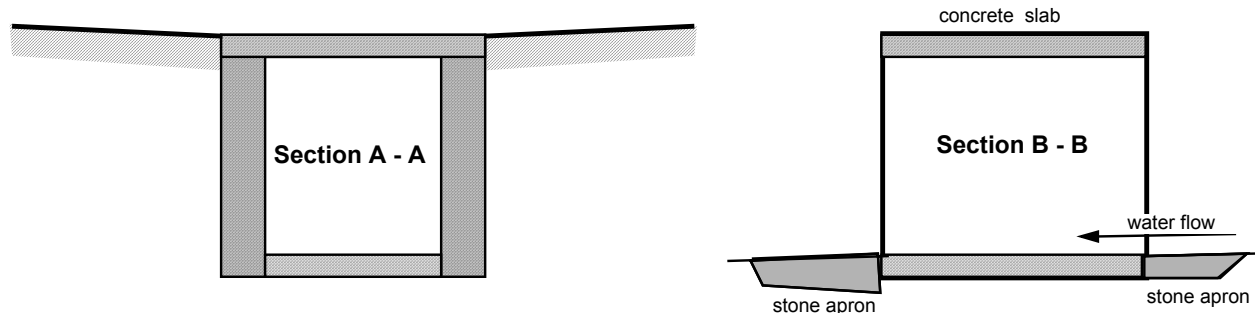

Arch Culvert

Apart from cement no material needs to be imported as locally available stones and sand can be used. Building arches requires special skills.

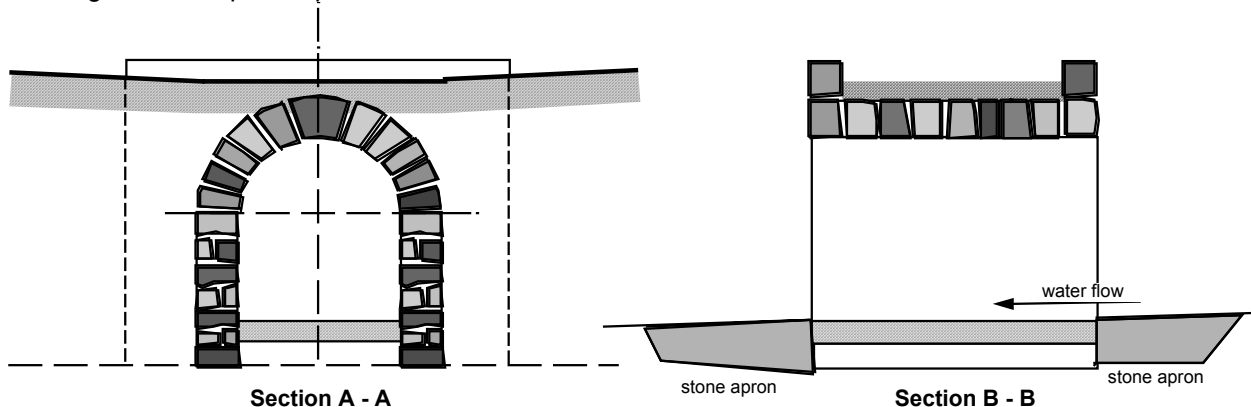

E.9.3 Important Considerations for the Construction of Structures

It is a fact that many contractors lose money on structure works due to their negligence of details, lack of proper planning and making wrong assumptions. Very often work that is not directly part of the construction of the structure is simply forgotten or underestimated. This is particularly the case with regards to river training works and diversion of the water flow to keep the work site dry. These are work items that are difficult to estimate and require some degree of experience and professional imagination. The following list is meant to assist in the estimating and planning process for structure works:

Structure Site:

- Investigate the **access to the structure site**. Is it accessible with transport vehicles such as lorries or tractors? If not, what needs to be done to improve the access?
- Is there a place next to the structure for a **site camp with space** for i) simple camp facilities ii) storing construction material, iii) mixing concrete / mortar, and iv) preparing form work, gabions, re-bars, cement blocks, etc.?
- Where is the next source for **construction water** in the case where a structure has to build in a seasonal watercourse?
- Can the **site camp** be placed on a spot that is **safe during rains / floods**?

Preparing the Work:

- **Study carefully all construction drawings** and compare them with the real situation on site. Note all issues that are not clear or which you cannot fully understand. Ask the Engineer to clarify. In the case where drawings are unclear, not sufficiently detailed or incorrect, ask the Engineer to give proper instructions in writing or by providing new drawings. Additional sketches might also help.
- **Prepare a detailed work plan**. Subdivide the work into all working activities that have to be carried out on a step-by-step basis (chronological order). Estimate carefully the time that is required. Inform the Engineer about your detailed work plan and get his/her consent.
- In the case where **works cannot be completed during the dry season**, investigate carefully what the consequences are. Prepare a proposal on how to deal with the problem and discuss it with the Engineer. This is particularly important when you have prepared your estimates on the assumption that all works could be completed during the dry season. You may have to request for a variation order if the work-start was delayed by the client, and hence your original work programme can no longer be observed.
- Based on the work plan develop a detailed **resources plan** (labour, equipment, tools and material) that covers all the working steps. Consequently you can then develop a **transport plan**, which details what and when to transport.
- Make sure that the Engineer provides **sufficient and accurate benchmarks** from which you can easily transfer levels to the various structure elements. Do not assume yourselves levels, as these are the responsibility of the Engineer.
- Make sure you have **sufficient skilled labour** on site that can master structure works!
- Have your own **quality assurance** system in place → see Modules G, H, and I.



Most important: Do not forget to study carefully all construction drawings and compare them with the real situation on site!

Building the Structure:

- **Clear the site** totally from bush and grass including the area well above and below the actual structure site.
- Start excavation work only when the structure to be built has been properly **set out** (pegs, wire lines, levels) and the Engineer has approved the setting out.
- In the case of constant water flow, start by **diverting** it to one side of the bed so that work can be carried out on the dry side. Sand bags and water pumps are often required for this exercise. Make sure your labourers are safe when working in water, e.g. provide gumboots, install a water pump.
- It is advisable to carry out **river bank protection works before or in parallel** with the actual structure works in order to ensure that the water flow does not change the path and endangers your structure site and labourers working on it.
- Before you cast or lay any foundation, make sure the **Engineer approves in writing the foundation levels and dimensions!** The same applies for **reinforcement** before casting concrete.
- Make sure the **Engineer approves the levels and dimensions** of any further structure element before you continue with the next one.
- Drift slabs can often not be cast in one day either because there of constant water flow on one side of the riverbed (diverted) or because the slab is simply too long. Therefore, proper **construction joints** have to be provided → see details in Module G, Concrete Technology, Section 7.4, Joints for Floors / Slabs.
- Request the Engineer on time to **measure all those work items that cannot be measured anymore at a later stage**. For example, the exact size of foundations can only be measured when the excavation is completed and before concrete is cast. The same applies for hardcore layers, blinding layers, apron fills, back fills, etc.
- When you complete a structure side make sure that the Engineers **approves all work** and that you hand-over the structure in writing based on the approval.

E.9.4 Gabion Works

- Gabions are wire mesh boxes filled with stones and tied together to form basic structures. They are used principally for retaining walls, drifts and erosion protection. The standard size of gabion boxes is: 2m length, 1m width and 1m height.
- Gabion boxes may be made from purpose made gabion cages, welded steel mesh sheets or galvanised chain link fencing.
- Foundations must be excavated level. Unsuitable material has to be removed and replaced with good soil, stone or gravel and compacted.
- Cages have to be woven together using 3mm galvanised binding wire, securing all edges every 0.15m with a double loop. Tighten the binding wire with a pair of heavy-duty pliers and secure with multiple twists.
- Stretch and stake the connected baskets with wires and pegs to achieve the required shape (all sides rectangular).
- Fill baskets by hand using hard durable stones not larger than 250 mm and not smaller than the size of the mesh. The best size range is 125 - 200 mm. Place the stones as if for dry stone masonry.
- Fill the boxes to 1/3 of the height. Fit horizontal bracing wires and tension with a windlass to keep the vertical faces even and free of bulges. Further bracings should be fixed after filling to 1/3 of the height.
- Lids are closed and stretched tightly over the stones, (carefully) using crowbars if necessary. The lid is securely woven to the tops of the walls using galvanised wire.

1. ASSEMBLE CAGE

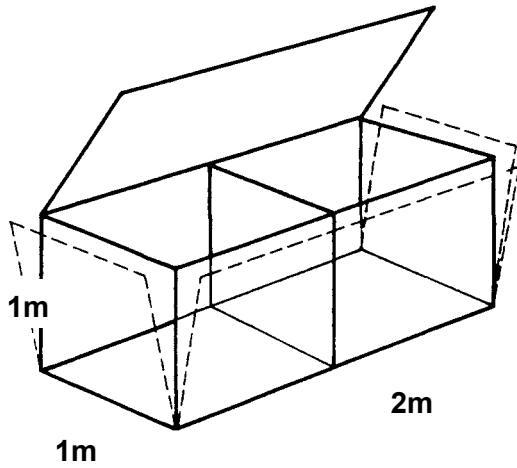

2. WEAVE BOXES SECURELY TOGETHER

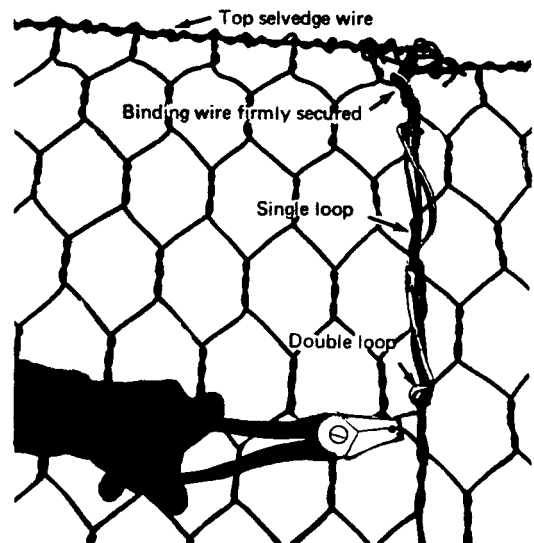

3. STAKE AND STRETCH CAGES TO REQUIRED SHAPE

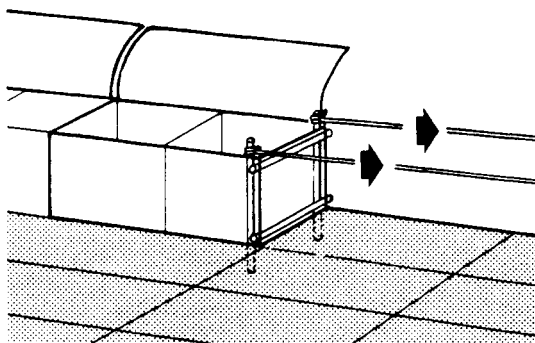

4. INTERMEDIATE BRACING

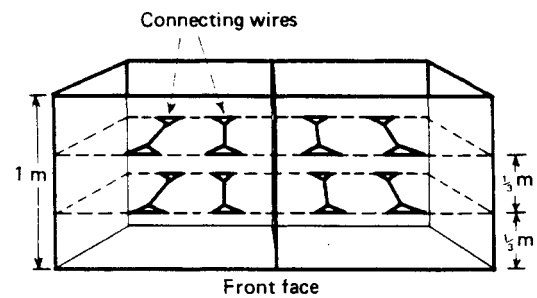

5. WINDLASS BRACING

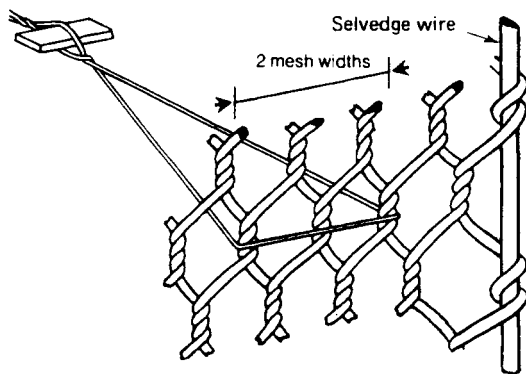

6. CLOSE AND SECURE LID

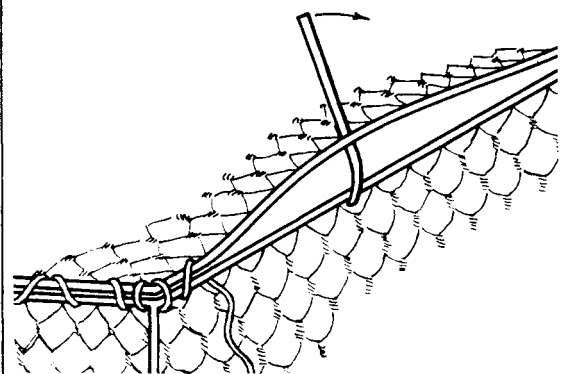

E.10 GRAVELLING

E.10.1 Planning and Organising Works

As for earth construction, gravelling is an operation that has to be well organised. Gravelling works are normally divided into two main activities: First preparation, and second the actual gravelling operations.

Preparation activities (normally carried out in advance of gravelling):

- Reshaping the road
- Preparing quarry access roads
- Preparing the quarries
- Initial excavation of gravel.

Actual gravelling activities:

- Main excavation of gravel in the quarry
- Loading
- Hauling
- Off loading and spreading
- Compaction
- Stockpiling of gravel for maintenance.



Gravelling is an expensive and complex operation. Careful planning and control of resources and productivity rates is essential.

The organisation of the labour gangs must be carefully balanced to suit the available equipment and average haul times between the quarry and the road site. The number of labourers required for loading and unloading/ spreading are directly related to the target number of loads to be hauled. Other activities are more independent. Particular attention should be paid to ensuring that a sufficient amount of gravel is excavated for the following day's haulage.



Ensure that a piece of equipment never stands idle on site. Equipment is too expensive to be parked!

Daily planning involves the following steps:

- Determining the available haulage capacity.
- Determining haulage distance and gravel haulage target.
- Verifying availability of gravel stockpiles.
- Allocating labour to the activities directly linked to the haulage operation (e.g. loading, off-loading, spreading, crushing of oversize stones, etc.).
- Allocating the remaining labour-force to the other activities.
- Crosschecking total labour requirement with usual attendance.
- Adjusting the number of trucks or tractors or labour gangs as necessary.

Gravel Quantities Required per KM Road						
Cross section	Average width of gravel surface (m)	Compacted gravel (m)	Loose Gravel (m)	Quantity loose	Quantity gravel (m³/km)	Total Quantity
A1	5.25	0.12	0.150	790	30	820
A2	4.75	0.12	0.150	710	30	740
B	3.75	0.10	0.125	470	30	500
C	3.25	0.10	0.125	410	30	440
D	6.00	0.20*	0.250	1,500	30	1,530
E	5.25	0.12	0.150	790	30	820

* Depending on the compaction equipment, gravel course may be spread and compacted in two layers.

E.10.2 Equipment and Tools

The choice of equipment depends on what is available to the contractor. Each type of equipment has its advantages and disadvantages. Basically the choice is determined by the cost.



When costing equipment ensure that all cost elements are considered; capital, operational and replacement costs!

Typical Graveling Equipment Set		
2 - 5 Tractors 4 - 10 Trailers	or	1 - 5 Trucks
1 - 2 Pedestrian Vibrating Rollers	or	1 Tractor with Towed Dead-weight Roller
1 Fuel Bowser (Towed)	or	10 - 20 Fuel Drums
1 Water Bowser (Towed)	or	Removable Tank on Haulage Truck

The exact number of trucks or tractors and trailers depends on the haul distances, gravel width and thickness and available labour, and should be adjusted accordingly.



- **For equipment service and repair refer to Module L, Maintenance of Plants and Vehicles.**
- **For graveling handtools refer to Module C, Site Camp and Tools, Section C.3, Hand Tools.**
- **For detailed explanations of graveling operations refer to the Technical Manual for Labour Based Road Rehabilitation (MOWS), Chapter J.**

E.10.3 Activities

Activity Sheet G1 <i>RESHAPING</i>	
<p>Work Method: The road to be gravelled must be first brought back to its original cross-section if i) gravelling does not follow immediately after formation and ii) if an existing road is being re-gravelled.</p> <ul style="list-style-type: none"> • Carry out reshaping immediately in advance of the gravelling operation. • For light reshaping allocate one gang (camber reshaping, shoulder reshaping). • For heavy reshaping allocate two gangs, one for the carriageway activities and one for drainage cleaning. • If necessary establish exact width to be reshaped using pegs and strings. • Define quantity of work for the day and allocate labourers accordingly. 	
<p>Labour: 1 Site Supervisor (part time) 1 Gang Leader Labourers</p>	<p>Tools and Equipment:</p> <ul style="list-style-type: none"> • Tape measures, 5 and 30m • Hammer • Camber Template and spirit level • Rakes • Hoes • Shovels • Tractor and towed grader
<p>Suggested Productivity Range: For light reshaping: • 20 to 50 m of road / day / labourer For heavy reshaping and cleaning drainage: • Use task rates as for construction</p>	<p>Actual Productivity:</p>

Activity Sheet G2 <i>PREPARING QUARRY ACCESS ROAD</i>	
<p>Work Method: Where the quarry is not within the road reserve or located directly along an existing road, an access track has to be constructed or improved.</p> <ul style="list-style-type: none"> • Assess work that needs to be done and divide into activities as for construction, e.g. excavation, forming camber, opening drainage • Define quantity of work for the day and allocate labourers accordingly. • Allocate labourer to continuously maintain the access road. 	
<p>Labour: 1 Gang Leader Labourers</p>	<p>Tools and Equipment:</p> <ul style="list-style-type: none"> • Handtools and equipment as per work required
<p>Suggested Productivity Range: Identify activities as for construction → use task rates accordingly</p>	<p>Actual Productivity:</p>

Activity Sheet **G3** **QUARRY PREPARATION**

Requirements:

Make arrangements so that the quarry can be optimally exploited, environmental damage is limited, overburden can be stockpiled for quarry reinstatement, and the quality gravel can be extracted where the quality of the gravel varies. You may need to re-check the quality of the gravel. Inform the Engineer if the quality is doubtful before starting excavating (→ also refer to quality field test at the end of this module).

Work Method:

- Setting out the boundaries of the quarry using pegs or boning rods so that the gangleader and labourers know exactly where the quarry is.
- Define quantities of work activities for the day and allocate labourers accordingly
- Clear bush and dig out roots. Remove debris from quarry.
- Excavate overburden (top soil / humus) and stockpile on approved and secure place.

Quarry without Access Road:

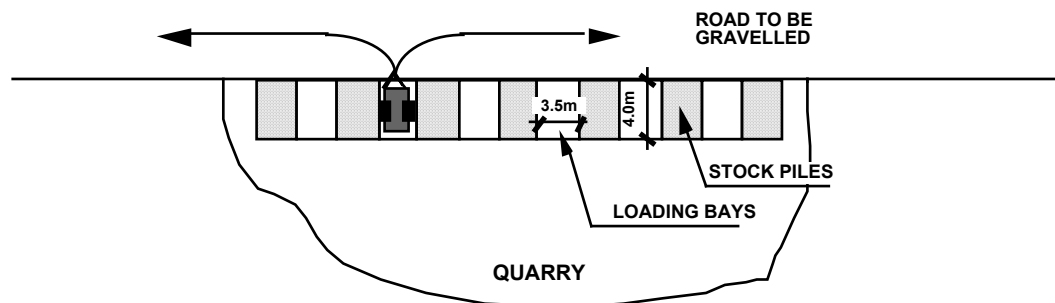

Quarry with Access Road:

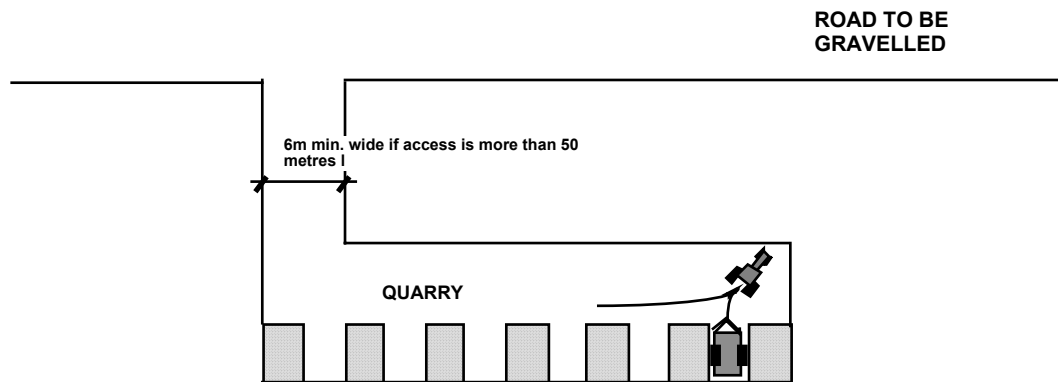

Labour:
 1 Site Supervisor (part time)
 1 Gang Leader
 Labourers

Tools and Equipment:
 • Tape measures, 5 and 30m
 • Bush knives, Axes
 • Hoes, Pickaxes
 • Shovels, Wheelbarrows

Material:
 • Strings
 • Pegs

Suggested Productivity Range:

- Bush clearing = 300 – 800 m² / day / labourer
- Excavating overburden + loading onto wheelbarrow = 2 – 4 m³ / day / labourer
- Hauling overburden =
 - 0 - 40m = 10,5 m³ / day / labourer
 - 40 – 60m = 8 m³ / day / labourer
 - 60 – 80m = 6.5 m³ / day / labourer
 - 80 – 100m = 5.5 m³ / day / labourer

Actual Productivity:

Activity Sheet

G4

Gravel Excavation

Quarry Arrangements:

Where possible, bays should be excavated and the gravel stockpiled alongside. In this way the gravel is always cast down into or from the same level as the trailers or lorries.

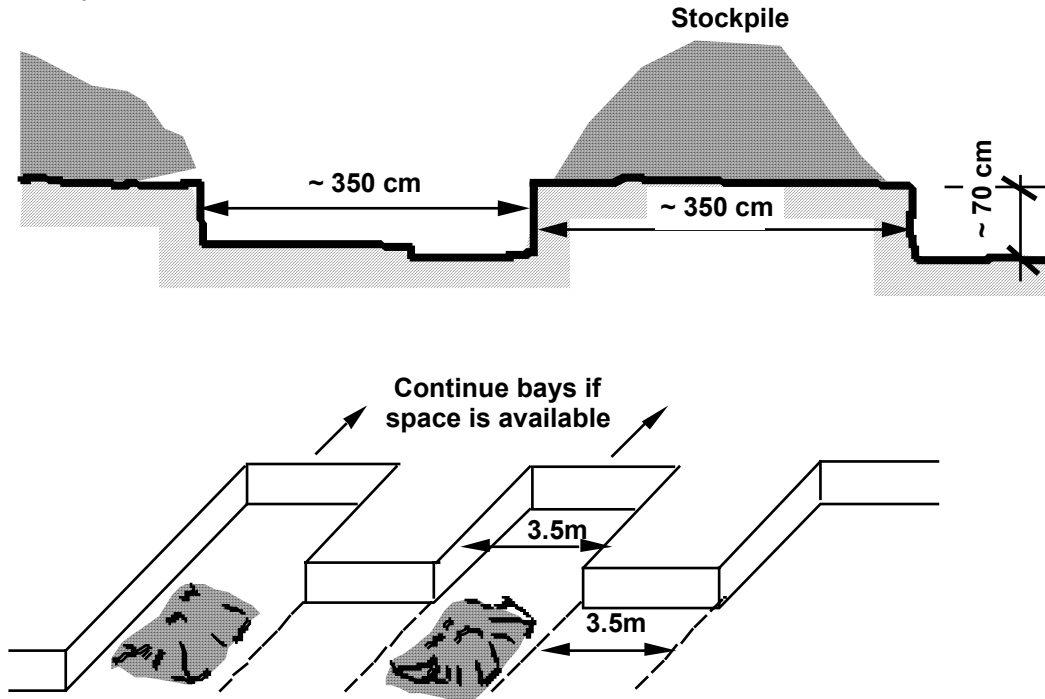

Standard excavation bay ca. 3.5m wide and 0.7m high will allow stockpile between bays. Trailer or lorry can be easily reversed into loading bays. A 4m long bay will give about 12m³ of gravel (loose) or 4 trailers loads □ 4qm

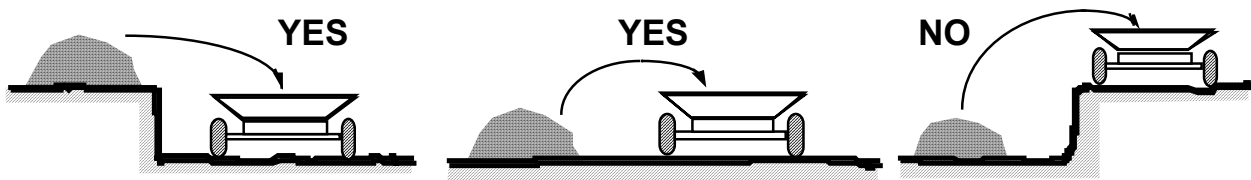

Work Method:

- Set out the bays to be excavated and the place where gravel has to be stockpiled.
- Define quantities of work activities for the day and allocate labourers accordingly.
- Always excavate sufficient gravel to ensure that the haulage equipment on the next day can be fully utilised.

Labour:
 1 Site Supervisor (part time)
 1 Gang Leader
 Labourers

Tools and Equipment:
 • Tape measures, 5 and 30m
 • Pickaxes and Crowbars
 • Hoes and Mattocks
 • Shovels

Material:
 • Strings
 • Pegs

Suggested Productivity Range:
 • Excavating insitu gravel = 1.6 – 2-4 m³ / day / lab.
 • Excavating loose gravel = 2 – 3 m³ / day / labourer

Actual Productivity:

Activity Sheet **G5** **LOADING GRAVEL**

Work Method:

Loading stockpiled gravel onto trucks or tractor trailer:

- Calculate the hauling trips to be made for the day (see tables hauling equipment and hauling distances) and the labour required for loading this equipment.
- Divide the loading gang into groups of 4 – 6 labourers for tractor-trailers, or 8 – 10 labourers for trucks.
- Load trailers / trucks in the order in which they arrive in the quarry. Fill flash with top of the bodywork (defined quantity for each piece of hauling equipment).
- Continue with excavation to have sufficient stockpiled gravel for the following day.

1. Loading Operation First Day □

□
(start loading of material at the far end of bay)

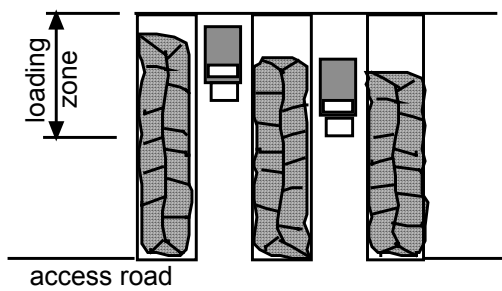

2. Loading Operation Second Day □

(loading at the near end of bay and excavation to continue where loading was done the previous day at the far end of the bay)

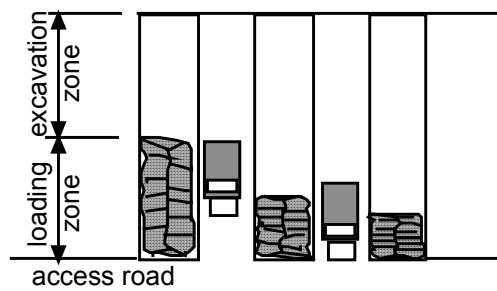

Labour:

1 Site Supervisor (part time)
1 Gang Leader
Labourers

Tools and Equipment:

- Hoes
- Shovels

Material:

Suggested Productivity Range:

For light reshaping:

- loading gravel onto trailer = 8 – 10m³ / day / labourer (loose gravel)
- loading gravel onto truck = 5 – 7.5m³ / day / labourer (loose gravel)

Actual Productivity:

Activity Sheet

G6

HAULING GRAVEL

Work Method:

The haul distance, type of equipment used and condition of the haul route determine the quantity of gravel that can be hauled in a day by each operational piece of haulage equipment.

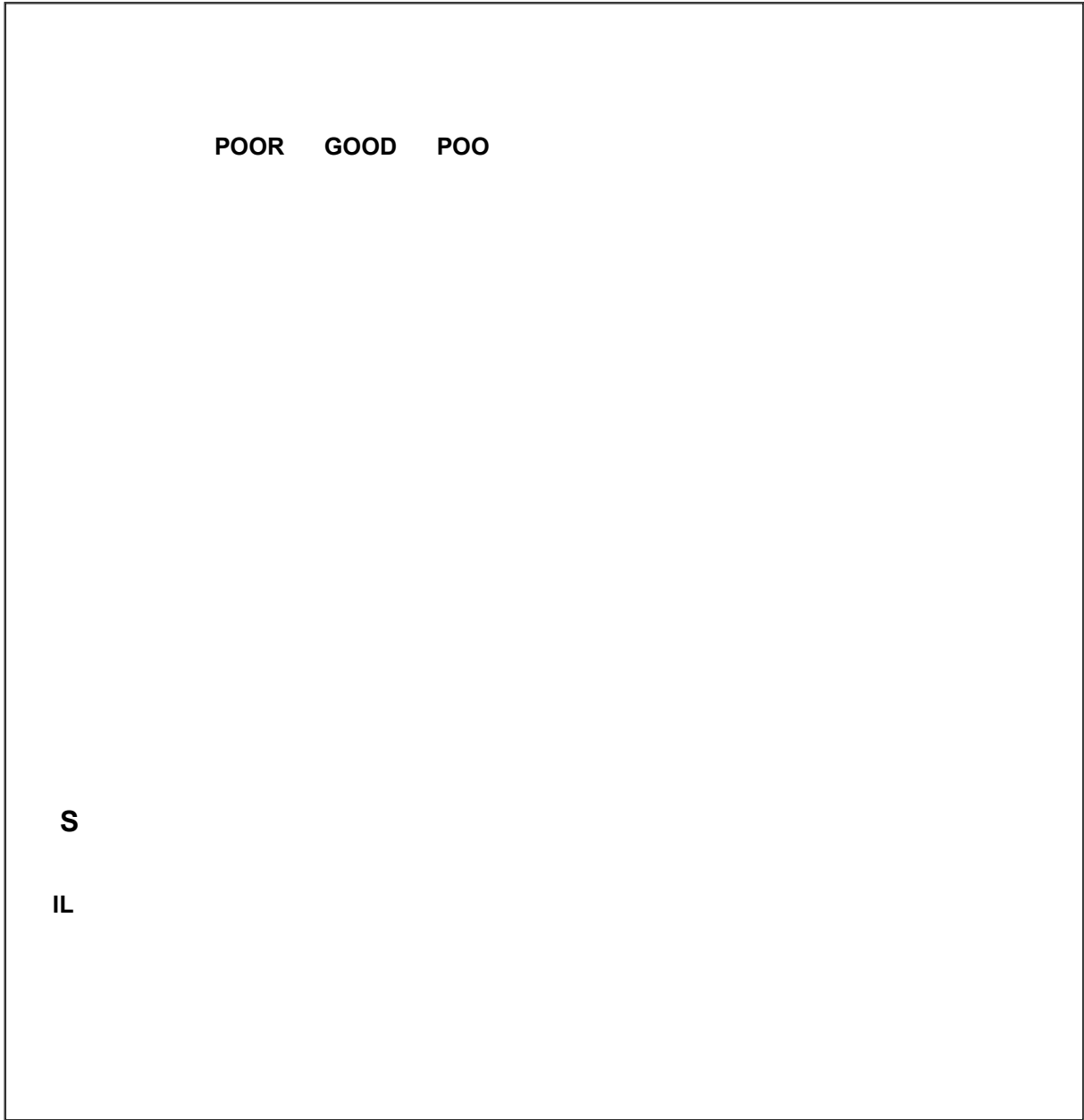

POOR = poor haul route

GOOD = good haul route

Note: For trucks, more than for tractor/trailer combinations, the quality of the haul route and good work organisation are important for enhancing daily haulage productivity.

Activity Sheet

G7

OFF-LOADING AND SPREADING GRAVEL

Work Method:

This is a combined activity, carried out by one gang of labourers. It is important that the trucks or trailers are off-loaded in the shortest possible time.

- Set out off-loading and spreading boxes using pegs and strings in accordance with the volume of the haulage equipment. Box width according to standard width of surface, length of box = trailer or truck capacity divided by road width multiplied by layer thickness (loose) → for standard 3m³ trailers and 5m³ trucks see reference tables next page.
- Pegs to be set at the centre line and edge of box to ensure a satisfactory cross fall (8% = use camber board) and longitudinal gradient (use boning rods).
- From the haulage table (activity sheet G6) calculate the total volume of gravel to be spread for the day. Allocate labourers accordingly.
- Offload gravel and spread immediately using hoes and heavy-duty rakes or spreaders. Any gravel lumps or stones larger than 63mm should be broken down using sledge hammers

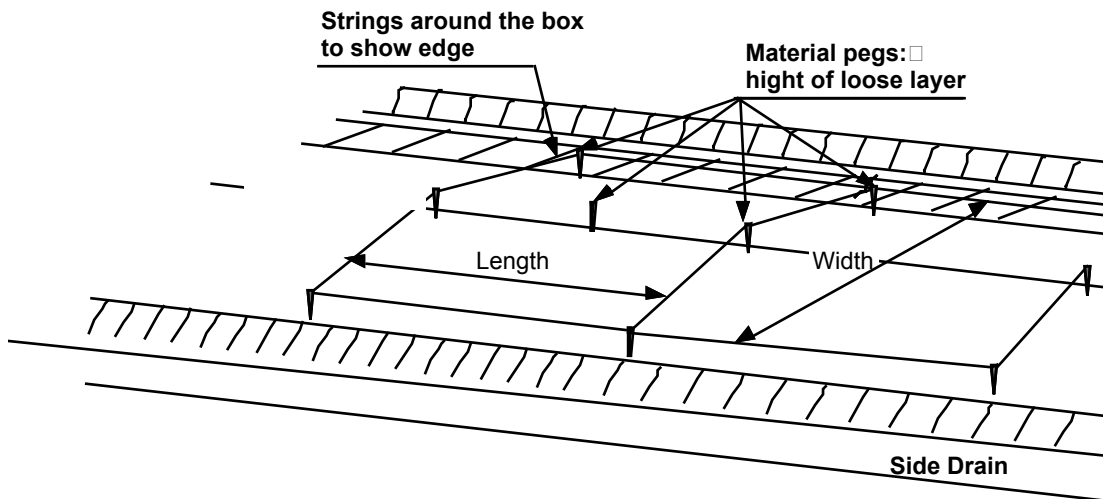

Labour:

1 Site Supervisor (part time)
1 Gang Leader
Labourers

Tools and Equipment:

- Hoes
- Shovels
- Heavy Duty Rakes or Spreaders
- Sledge Hammer
- Camber Board + Spirit Level
- Boning Rods

Material:

- Pegs
- Strings

Suggested Productivity Range:

Offloading and spreading = 12 – 16m³ / day / labourer

Actual Productivity:

UNLOADING GRAVEL: "BOX" DIMENSIONS - 3m³ TRAILERS

ROAD TYPE (CROSS SECTION)	GRAVEL WIDTH (AVERAGE) (m)	GRAVEL THICKNESS (COMPACTED) (m)	GRAVEL THICKNESS (LOOSE) (m)	BOX LENGTH (3m ³ TRAILER) (m)
STANDARD (A1) } EMBANKMENT (E) }	5.25 5.25	0.12 0.20	0.15 0.25	3.80 4.60*
STANDARD (A2)	4.75 4.75	0.12 0.20	0.15 0.25	4.20 5.10*
REDUCED CS (B)	3.75	0.10	0.125	6.20
MOUNTAIN (C)	3.25	0.10	0.125	7.40
BLACK COTTON (D)	6.00	0.20	0.25	4.00*

* Gravel to be laid in two separated layers of 0.125m thickness using these box dimensions.

UNLOADING GRAVEL: "BOX" DIMENSIONS - 5m³

ROAD TYPE (CROSS SECTION)	GRAVEL WIDTH (AVERAGE) (m)	GRAVEL THICKNESS (COMPACTED) (m)	GRAVEL THICKNESS (LOOSE) (m)	BOX LENGTH (5m ³ TRUCK) (m)
STANDARD (A1) } EMBANKMENT (E) }	5.25 5.25	0.12 0.20	0.15 0.25	6.30 7.60*
STANDARD (A2)	4.75 4.75	0.12 0.20	0.15 0.25	7.00 8.40*
REDUCED CS (B)	3.75	0.10	0.125	10.70
MOUNTAIN (C)	3.25	0.10	0.125	12.30
BLACK COTTON (D)	6.00	0.20	0.25	6.70*

* Gravel to be laid in two separated layers of 0.125m thickness using these box dimensions.

Activity Sheet **G8** **COMPACTION**

The required degree of compaction is specified in the contract. An initial compaction can be achieved by driving with the haulage equipment over the newly spread gravel (→ start gravelling from the quarry). Full compaction has to be achieved with appropriate equipment.

→ For details on compaction and compaction equipment refer to Module F

Work Method:

- Water the gravel to achieve the optimum moisture content as required by the specifications.
- Wait sometime for the water to penetrate the gravel material. Where the water cannot penetrate the gravel, mixing might be required. Watering during the spreading operation is an economic way of ensuring that the gravel is uniformly moist.
- Compact using equipment, e.g. pedestrian vibrating roller or towed dead weight roller.
- The number of passes has to be determined through tests. Usually 6 to 8 passes are sufficient if the moisture content is optimal.
- Ensure uniform rolling and number of passes. Also ensure that there is always a lateral overlap of at least 20cm from pass to pass.

Labour:
 1 Gangleader
 1 Hauling equipment operator
 1 labourer to clean the roller drum (sometimes required where gravel sticks on drum)

Tools and Equipment:

- Pedestrian Vibrating Roller or Dead Weight Roller
- Water Bowser

Material:

- Water

Suggested Productivity Range:

→ see tables in Module F

Actual Productivity:

E.10.4 Quality Control for Gravelling

GRAVEL SOURCE TESTS (FOR BASE LAYER)				
<p>(i) Type of tests: Check on the suitability of a gravel source for surface layer. Unlike most other tests, the client can only carry out these tests in the laboratory before construction commences. However, if you are doubtful about the quality of the material you may use a simple field test to identify the suitability of the chosen gravel. If the test described below shows doubtful results, then the client should be consulted for further instructions.</p> <p>(ii) Methods used: - "Bottle" test to identify the grading. - Moulding and drying test to identify plasticity and strength</p>				
Test	Method	Location	When?	Tolerance
Grading	bottle	field	when in doubt of quality	NA
Plasticity	moulding	field	when in doubt of quality	NA
Strength	drying	field	when in doubt of quality	NA

GRAVEL LAYER TESTS (FOR BASE OR SURFACE LAYER)				
<p>(i) Type of tests: Tests on the thickness and degree of compaction of the finished base layer.</p> <p>(ii) Methods used: - Tapes are used to measure the gravel thickness. - Special laboratory tests are used by the client to measure the degree of compaction. A simple way of ensuring the compaction is achieved is by ensuring that the required minimum number of compaction passes, at optimum moisture content, are actually made. This method does not provide the contractor with the actual result but ensures that the desired compaction is achieved in most cases.</p>				
Test	Method	Location	Test Interval (every ..)	Tolerance
Thickness of gravel layer	tape	field	50 m (in centre and towards edge)	+/- 10 mm
Degree of compaction	counting compaction passes	field	always	0

MODULE F:

COM

F.1	Introduction	F-1
F.2	Factors Influencing Compaction	F-1
F.3	Compaction Plant	F-2
F.4	Field Density Tests	F-4

F.1 INTRODUCTION

Soil compaction is the process whereby soil particles are constrained to pack more closely together through a reduction of the air voids, generally by mechanical means. Under compaction, soil will reduce its volume and therefore its density will increase. In road construction, the compaction of soil is important for three main reasons:

- it increases the strength of soil,
- it reduces the permeability, thus reducing moisture content changes (water cannot enter the soil easily and change its strength),
- it reduces the settlement and increases resistance to deformation.

The level of compaction to be achieved in the field during construction is normally specified as a percentage of the maximum dry density obtained in a compaction test in the laboratory. This is usually described in the contract specifications as shown by the following example:

“Unless otherwise specified, the layers of fill material shall be compacted throughout to a dry density of at least 95% MDD (Standard Compaction), except for the upper 300 mm which shall be compacted to a dry density of at least 100% MDD (Standard Compaction).”

How this compaction is achieved is left to the contractor. The client is only interested in the end result or product. This specification is therefore also referred to as “**Performance Specification**”. The client or his representative will check the achieved density before the work is accepted.

Another way of determining compaction is to specify the minimum number of passes to be carried out with a certain type of roller and with a specified moisture content of the soil. This is then referred to as “**Method Specification**”. The client or his representative will have to check whether the required number of passes are actually carried out by the contractor and whether he adheres to the specified moisture content.



When reading this Module F, it is also recommended that you consult Module B. Soils, for reference purposes.

F.2 FACTORS INFLUENCING COMPACTION

Coarse grained soils (gravel and sand):

Good compaction in coarse-grained soils depends upon particle-size distribution. The best results are achieved with “well-graded” soil. Poorly graded soils will have a high air content even when compacted. As for concrete, the finer particles of a “well-graded” coarse soil will fill the gaps between the larger particles and thus decrease air voids. A small proportion of clay not exceeding 12% will in most cases, improve the stability of compacted coarse-grained soil by acting as a binder.

Fine grained soils:

Silts and silty soils, e.g. black cotton soil, are extremely difficult to compact and very unstable in the presence of water. If possible, they should be avoided in any type of construction.

Clay and clayey soils can normally only be compacted when in a plastic state (optimum moisture content). Clay and clayey soils can be used as fill material on some occasions.

Moisture content:

The degree to which compaction can be achieved is governed by the moisture content. If the soil is too dry, friction between particles tends to resist close packing. If the soil is too wet, the water between particles prevents close packing. Therefore, there is an **optimum moisture content** at which a maximum density is achieved. As rule of thumb, the optimum moisture content of the soil can be checked in the field by squeezing a sample in the hand:

- if the material is too dry, it will not stick together and must be thoroughly mixed with water before compacting it,
- if water runs out of the material, it is too wet and should not be compacted but left to dry out until the moisture content has reduced,
- if the material is wet enough to stick (you can form a ball), it has the optimum moisture content and is suitable for compaction.

Amount of compaction:

The degree of compaction that is achieved in a certain volume of material is a function of the compactive effort applied. Within practical limits, the higher the compactive effort, the higher is the density that will be achieved and therefore the more stable the soil will be. The compactive effort or amount of compaction applied to a soil can vary in two ways:

1. by varying the type of compaction plant (a 3 tonne roller will obviously achieve a smaller compactive effort than a 8 tonne roller), and
2. by varying the number of passes.

Each plant, however, has an upper limit of compactive effort, beyond which additional passes have no further effect. As a general rule, this upper limit is reached after **about 6 passes**.



Thickness of layer:

The thicker the layer of loose material that is being compacted, the less the average density will be and therefore the stability resulting from a certain compactive effort. As a general rule, the loose layer to be compacted should not be less than 10cm and the maximum thickness may range from 10 cm to 40cm depending on the roller to be used (see tables below).

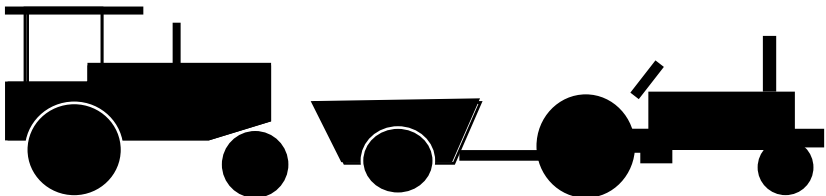

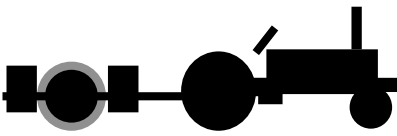
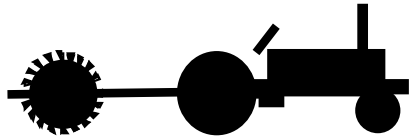
F.3 COMPACTION PLANT

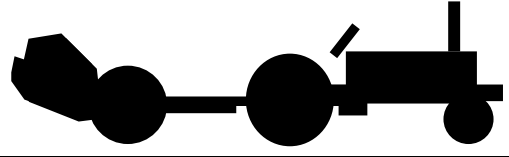
<p>smooth wheeled rollers; self propelled or drawn</p> <p><u>suitability:</u> for light clayey and well graded soils</p>		 <p>note: tractor drawn dead weight rollers are often used on labour-based road sites</p>			
operational weight	t	2.5 to 4.5	4.5 to 7.0	7.0 to 10.0	10.0 to 15.0
roller width	cm	100 to 150	145 to 175	150 to 195	180 to 210
working speed	km/hr	1.5 to 3.0	1.5 to 3.0	1.5 to 3.0	1.5 to 3.0
thickness loose layer	cm	10	15	20	25
approx. passes	No.	4 to 8	4 to 8	4 to 8	4 to 8

1. grid rollers <u>suitability:</u> for light clayey and well graded soils 2. tamping rollers <u>suitability:</u> clayey soils		1. 	2. 
operational weight	t	15	2.5 to 8.5
roller width	cm	175	120 to 150
working speed	km/hr	2.4 to 4.8	2.4 to 4.8
thickness loose layer	cm	20 to 40	20 to 30
approx. passes	No.	4 to 8	8 to 16

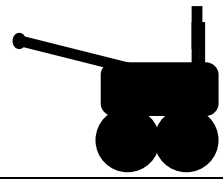
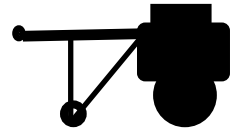
1. towed vibrating rollers <u>suitability:</u> for light clayey and well graded soils 2. self propelled double vibrating rollers <u>suitability:</u> for light clayey and well graded soils		1. 	2. 
operational weight	t	3 to 5	1 to 5
roller width	cm	140 to 190	80 to 110
working speed	km/hr	1 to 3	1 to 2
thickness loose layer	cm	30	15 to 30
approx. passes	No.	2 to 4	2 to 4

1. pedestrian tandem vibrating rollers <u>suitability:</u> for light clayey and well graded soils 2. pedestrian vibrating rollers <u>suitability:</u> clayey soils		1. 	2. 
operational weight	t	1 to 1.5	0.5 to 1.0
roller width	cm	90	70 to 80
working speed	km/hr	1 to 2	1 to 2
thickness loose layer	cm	15 to 20	15
approx. passes	No.	4 to 6	4 to 6

1. vibro tampers <u>suitability:</u> for light clayey and well graded soils 2. dropping weight compactors <u>suitability:</u> all soils		1.  note: for compaction of backfill only	2.  note: for compaction of backfill only
operational weight	kg	100	50 to 100
compacting area	cm ²	1000 to 1600	890 to 530
blows / min	No.	500	60 to 80
thickness loose layer	cm	20 to 30	20
approx. passes	No.	2 to 4	2 to 4



The operational details and specifications indicated for the various rollers are of a general nature and are meant to provide an overview only. More accurate data can be obtained from the manufacturers and from experienced contractors.

F.4 FIELD DENSITY TESTS

To control whether the required compaction has been achieved density tests have to be regularly taken during the construction period. This is part of the measurement procedure of the client or his representative.

However, as a contractor you are also interested to find out yourself:

- whether the density specified in the contract has been achieved before the client measures, and
- what the minimum compaction operation is to achieve this required density so that you do not carry out more work and spend more money than what is actually required.

Large-scale contractors are required to establish a site laboratory where both the client and the contractor can carry out the tests. For small-scale contracts, where mainly labour is used, such laboratories are usually not set up. However, tests can still be carried out by, for example using the laboratory facilities of Road Departments or Material Departments.

Several methods are used for determining the achieved field density:

Drive Cylinder:

This is the simplest method where a fixed volume of soil is removed by driving a thin-walled cylinder down into the soil. The sample is taken to the laboratory where the dry weight is determined. The dry density is calculated by dividing the oven-dried mass of the soil specimen by its volume. The method is not applicable to friable soils (soil that crumbles, e.g. too much clay content) and soil containing coarse material, e.g. gravel layer.

Rubber Balloon:

With the rubber balloon method the volume of the test hole is determined by measuring the volume of water necessary to fill the hole after a thin, elastic, watertight membrane (balloon) has been inserted into the hole. A slight pressure is applied to the water to ensure complete filling of the test hole.

Sand Replacement:

The sand replacement or sand cone method is widely used to determine the density of compacted soils. A sample is removed by hand excavating a hole in the soil. The in situ volume of the sample is determined by measuring the volume of dry, free-flow sand necessary to fill the hole. A special cone is used to pour the sand into the hole. The dry weight of the sample is determined in the laboratory. The method is not recommended for soils that are soft, friable or in a saturated condition.

Nuclear Density Gauge:

This apparatus uses gamma rays to measure wet density (total density) and neutrons to measure the water content. The results are immediately available at site and it is therefore not a laboratory test. It is necessary to calibrate the results with direct measurements of density and water content of each soil type encountered at site. The gauge is very costly and therefore usually used on large equipment-based sites. Safe handling is of the utmost important, as the gauge is potentially dangerous.

Dynamic Cone Penetrometer (DCP):

The DCP is an instrument designed for the rapid in-situ measurement of the structural properties of existing road pavements and base/sub-base layers with unbound materials (earth or gravel for example). Continuous measurements can be made to a depth of 800mm and with an extension rod to 1200mm. A correlation can be established between the DCP measurements and the California Bearing Ratio (CBR) so that results can be interpreted and compared with CBR specifications. This instrument is easy to use in the field and provides quick results. It is often used on labour-based road sites.

MODULE G:

CONCRETE TECHNOLOGY

G.1	Introduction	G-1
G.2	Materials for Concrete	G-1
G.2.1	Aggregates	G-1
G.2.2	Cement	G-1
G.2.3	Water	G-2
G.3	Types of Concrete	G-2
G.4	Mixing of Concrete	G-3
G.4.1	Batching	G-3
G.4.2	Mixing	G-3
G.4.3	Water Cement Ratio	G-4
G.5	Transporting Concrete	G-5
G.6	Placing Concrete	G-5
G.7	Construction Joints	G-6
G.7.1	Definition and Purpose	G-6
G.7.2	Construction Joint Between Foundation and Wall	G-6
G.7.3	Joints for Retaining Walls	G-7
G.7.4	Joints for Floor Slabs	G-8
G.8	Curing Concrete	G-8
G.9	Removal of Formwork	G-8
G.10	Quality Control for Concrete Works	G-9

G.1 INTRODUCTION

In labour-based road works, concrete is mainly used for structures, like bridges, box culverts and drifts but it is also used for the fabrication of culvert rings. In order to achieve the required structural strength and specified quality, it is important to adopt the correct procedures when working with concrete. This module provides simple guidelines on how to work with concrete on site.



For more details refer to the Technical Manual for Labour Based Road Rehabilitation (MOWS), Chapter H-2, Concrete Technology.

Concrete is a mixture of Mineral Aggregates (stone/gravel/sand). Cement, and Water.

After mixing these ingredients in controlled proportions, the concrete begins to harden after 1/2 to 1 hour due to the chemical reaction of the cement with the water. The hardening time takes 12 hours but continues gaining strength. After 28 days approximately 90% of the final strength is achieved (the usual period after which strength testing is carried out).

G.2 MATERIALS FOR CONCRETE

G.2.1 Aggregates

The aggregates are “fine” and “coarse”. Fine aggregate is **sand up to 2 mm** and coarse aggregates are **stones from 2 mm up to 50 mm**. If sand is not easily available quarry dust can be used instead.

Grading; is the variation in the size of the aggregates and is usually defined in the contract specifications with the sieving curves to be used. As a general guideline for use on site the aggregates should be mixed in the following proportions:

- **1 part of fine aggregates,**
- **2 parts of coarse aggregates.**

Impurities; it is very important to use only clean aggregates as impurities, like organic material and clay, can cause considerable loss of strength in the finished concrete. If the aggregates need to be washed, attention must be given in order not to wash off the fine sand.

To assess the cleanliness of aggregates a simple **bottle test** can be carried out. Fill a clear bottle half with aggregates, add water to the top and shake well and then allow the aggregates to settle. After about 30 minutes, if the aggregate is clean, there should be no or very little (less than 5%) dirt or silt deposited on top of the aggregates and the water above should also be clear.

Storage of aggregates; if aggregates have to be stored for a longer period of time (e.g. at a culvert-manufacturing site) then distinct bays for the various aggregates should be constructed. On site aggregates should be deposited on a clean ground (no dirt and no topsoil) on clearly separate heaps to avoid uncontrolled mixing. During the rains it is also advisable to cover sand with a polyethylene sheet or tarpeline in order to avoid the fine particles being washed off.

G.2.2 Cement

Cement, also known as Ordinary Portland Cement (OPC) is produced from limestone and clay. It is normally sold in paper bags containing 50 kg each.



50 kg of cement equals 36 litres cement.

Storage; cement does not set unless exposed to humidity. It is, therefore, advisable to store cement in a shed, preferably without windows. A boarded floor or wooden platform raised above the ground is advisable. Bags:

- should not be stocked above man-height,
- should not touch the walls of the shed so that air can freely circulate,
- must be off-loaded by hand in order to keep the paper bags unbroken, and
- should be used up in rotation (first stocked - first used).

Hardened lumps found when opening the bag should be removed by sieving the cement.

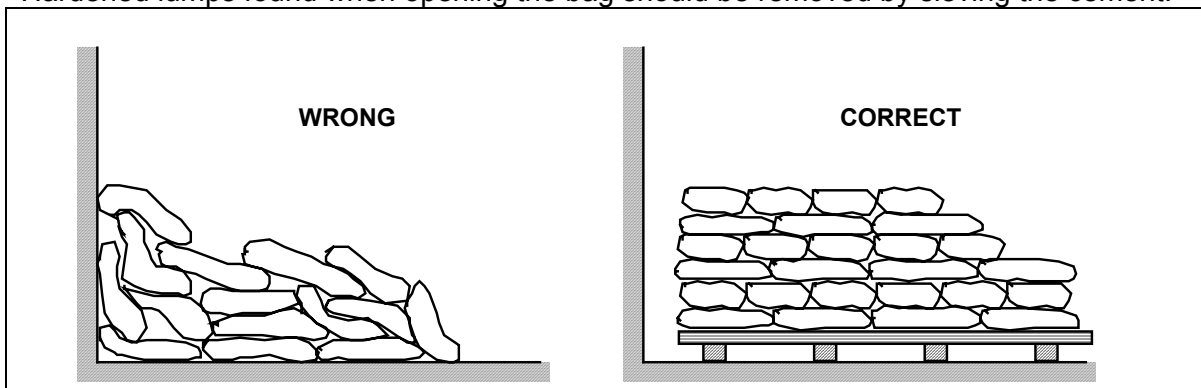

G.2.3 Water

Mixing **water must be clean**. It can be taken from rivers, lakes wells and from taps. Salt water (sea or lake), surface run-off water and water with other chemical or organic impurities must not be used. Dirty water with organic particles can be filled in a drum and used after these particles have settled at the bottom (use only the clean upper part of the water).

G.3 TYPES OF CONCRETE

The proportion of the mix affects the quality and strength of the concrete and varies therefore depending on its intended use. For labour-based road works the three following types are usually used:

Type	Use	Mix	Condition
Lean Concrete	<ul style="list-style-type: none"> • blinding of foundation excavation • culvert beds • culvert packing • other minor works where little strength is required 	1 : 4 : 8	Meagre mix with little cement content, stiff and not too wet
Mass Concrete (grade 15)	<ul style="list-style-type: none"> • gravity, non reinforced structures • culvert packing • kerb stone placing • concrete building blocks • etc. 	1 : 3 : 6	Medium mixture with more cement than lean concrete and with coarse aggregates up to 50 mm in size. The grade indicates the required strength of 15N/mm ² after 28 days.
Structural Concrete (grade 20 or 25)	<ul style="list-style-type: none"> • reinforced structures • reinforced and unreinforced culverts (note: RTS recommends concrete grade 25 for unreinforced culverts) • haunching of culverts where a bearing capacity is required • under-water concrete, reinforced or unreinforced 	1 : 2 : 4	“Fat” mixture with a high amount of cement and a maximum aggregate size of 20 mm to allow for culvert production and to easily pass around reinforcement bars. The grade indicates the required strength of 20 or 25N/mm ² after 28 days.

Note: the proportion of the mix is always = **cement : sand : stones**

There are higher grades of concrete (40 to 40) that are used in special cases (e.g. pre-cast bridge beams). These are usually not required for labour-based site works.



Always check in the contract specifications for the required concrete grade or mix. Consult the Engineer when you are in doubt or where it is not specified and ask for written instructions!

G.4 MIXING CONCRETE

G.4.1 Batching

Concrete on site is usually mixed by hand and where available with a power mixer. In order to achieve the required mix proportions **gauge boxes** are used to batch the dry aggregates. The box, made out of wood or metal, has the same volume as a bag of cement when filled level with the top = **36 litres**.

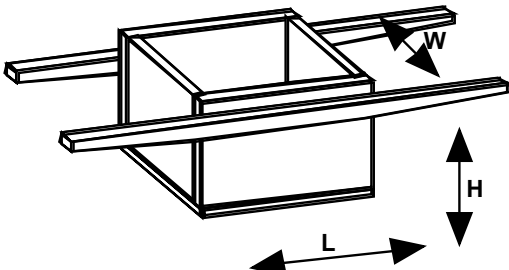

Inside measurements:

- length = 40 cm
- width = 30 cm
- height = 30 cm
- volume = 0.036 m³ = 36 litres

Batching by volume:

Concrete Type (Grade)	Mix by Volume Cement-Sand-Stones (Max. Stone Size)	Batch with 1 Bag of Cement			Material Required for 1 Cubic Metre		
		No. of boxes of Aggregates		Approx. Yield per Batch	Finished Concrete (Approximate)		
		Sand	Stones		Cement Bags (kg)	Sand (m ³)	Stones (m ³)
Lean	1 : 4 : 8 (40 mm)	4	8	0.30 m ³	3.3 (166 kg)	0.47	0.94
Mass (15)	1 : 3 : 6 (50 mm)	3	6	0.24 m ³	4.3 (215 kg)	0.46	0.92
Structural (20)I	1 : 2 : 4 (20 mm)	2	4	0.16 m ³	6 (300 kg)	0.42	0.84
Structural (25)	1 : 1.5 : 3 (20 mm)	1.5	3	0.14 m ³	7.3 (365 kg)	0.38	0.76

G.4.2 Mixing

Hand-mixed batches should not exceed 0.5 m³. The mixing should never be done on the bare ground, as this results in contamination of the mix. A platform of about 4m by 4m has to be built with either boards or metal sheets or lean concrete.

Procedure for mixing by hand:

- ◆ Measure the amount of sand and stones with the gauge box and put them in alternating layers on the platform.
- ◆ Spread the cement over it.
- ◆ The dry materials are mixed at least three times. Two persons, one on each side of the heap, shovel the heap to one side by turning the material in the process. This operation is repeated, the heap being thrown back to its original position and then back again until the colour of the dry mix is uniform.
- ◆ Water is then added by a third person while turning the mix the fourth time using a garden watering can or a bucket (use your hand to sprinkle from the bucket) so that the water is spread evenly while the material is mixed again. Only the correct amount of water should be added (see guideline below). The mixing must be continued (to be turned at least three times) until the concrete is uniformly wet and has reached the required consistency.
- ◆ Another often-applied method is to spread the dry mix, to make a hollow in the middle and then add the water into this hollow. Afterwards the mixing is done very carefully by avoiding that any of the water from the middle gets lost.

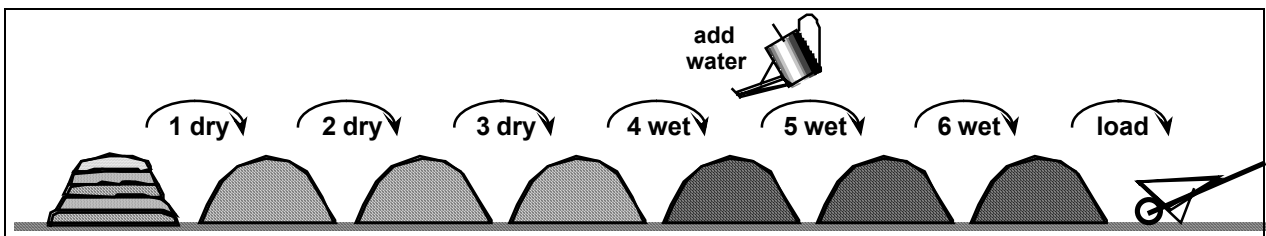
**G.4.3 Water-Cement Ratio**

The strength of concrete depends, to a great extent, on the amount of cool and clean water used in mixing. The amount of water used should be the minimum necessary to give sufficient workability for efficient consolidation of the concrete. The amount of water is specified by weight and stated as a fraction of the cement used or: **weight of water divided by weight of cement = water/cement factor.**

➔ **As an approximate rule the water/cement ratio equals 0.5. This means that the water content is usually 25 kg (or litres) to 50 kg or (one bag) of cement.**

Depending on the type of aggregate, the proportion of the mix and the natural moisture content of the mix, the water content can vary from:

- ➔
- 24 litres to 28 litres per bag of cement for concrete mixed by hand
 - 22 litres to 26 litres per bag for concrete mixed by plant

➔ **Every litre of water added in addition reduces the strength of the concrete equivalent to 2 - 3 kg of cement. Therefore, as a rule of thumb, the drier the concrete, the stronger.**

If the sand is damp (moisture can amount to up to 25% of the volume) then the added water quantity will need to be reduced.

A simple hand test helps to determine whether the mix has the right consistency and water content:

- ◆ Pick a handful of ready mixed concrete and form a ball in your hand. If this is not possible, then the mix is too wet.
- ◆ If it is possible to form a ball in your hand, drop this ball onto a hard surface...if the ball totally collapses, then the mix is too dry.

G.5 TRANSPORTING CONCRETE

Concrete should be **mixed as near as possible to the site** of placement to avoid segregation during transport and to shorten the time between mixing and placing. On site, concrete is usually transported in wheelbarrows.

G.6 PLACING CONCRETE

Concrete should be placed in position as soon as possible and before setting has begun. This allows a **maximum of 15 minutes** after mixing to transport and place the concrete.

The formwork or shuttering for the concrete must be clean, secure from movement or leakage and should be wetted before the concrete is filled in. Steel formwork should be oiled (old engine oil mixed with diesel will do) to allow it to be removed easily later.

For walls concrete has to be placed in layers of thickness not exceeding **30 cm when hand ramming**. This may be increased to **50 cm when a vibrating poker** is used. Each layer must be rammed or vibrated before the next is spread. As a rule of thumb, sufficient compaction is achieved when water appears on the surface and/or drips through the joints of the formwork, provided the water/cement ratio is correct and the formwork has been constructed with tied joints.

Hand ramming should be carried out using a round steel reinforcement bar (do not use a rammer). Pock the bar in small distances deep into the concrete layer, twist the bar and move at it at same time up and down. Repeat this procedure at every 10 to 15 cm. Excessive compaction of concrete causes disintegration of the mix. This is particularly risky when using the vibrating poker. The bigger stones sink to the ground and the water with the cement appears at the top.

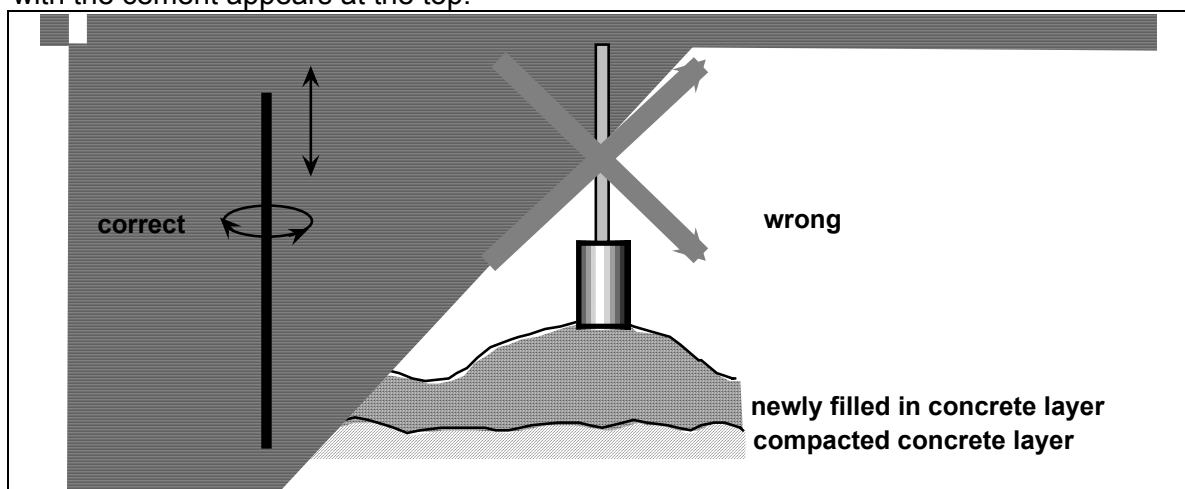

The formwork must be cleaned on the outside just after placing the concrete using a trowel, brush or broom. Do not use a hosepipe to splash water onto the formwork, as this would allow water to enter the joints and wash out the concrete.

The top or crown of the placed concrete should be given a smooth finish with a float. Only “cold” joints, where later more concrete will be added, need to be left rough to ensure a good bond for the next layer or element.

Adequate compaction for slabs can only be achieved with a vibrator.

G.7 CONSTRUCTION JOINTS

G.7.1 Definition and Purpose

Concrete constructions, especially large ones, are not totally rigid. Their form may change mainly due to shrinkage, temperature differences, settlement and earth movements. If the construction does not allow these form-changes to happen, then cracks and other damages will be the result. It is therefore essential that the Engineer plans for **Dilatation Joints** at the right places to avoid such damages.

Ensure that the Engineer provides you with all the necessary details and instructions for dilatation joints. Make sure the Engineer checks the dilatation construction arrangements before you cast the next element!

Besides dilatation joints there are also **Construction Joints** necessary for large concrete constructions. Construction joints are necessary because it is often not possible to cast the concrete of larger elements in one day. The work has to be interrupted and continued later. These construction joints can be easily predetermined and the correct arrangements made if the work is planned well = **planned construction joints**. However, due to unforeseen circumstances it could happen that concrete work cannot be completed as originally planned and an “**accidental joint**” needs to be made.

Dilatation and construction joints are required for all larger concrete constructions, for walls as well as for slabs. This module provides some practical guidelines for construction joints in retaining walls and floor slabs, such as for drift slabs.

G.7.2 Construction Joint Between Foundation and Wall

Due to the construction process a joint between the concrete foundation and the concrete wall (e.g. for a retaining wall) cannot be avoided. For retaining walls or larger abutments the construction joint should be constructed as shown in the following drawing:

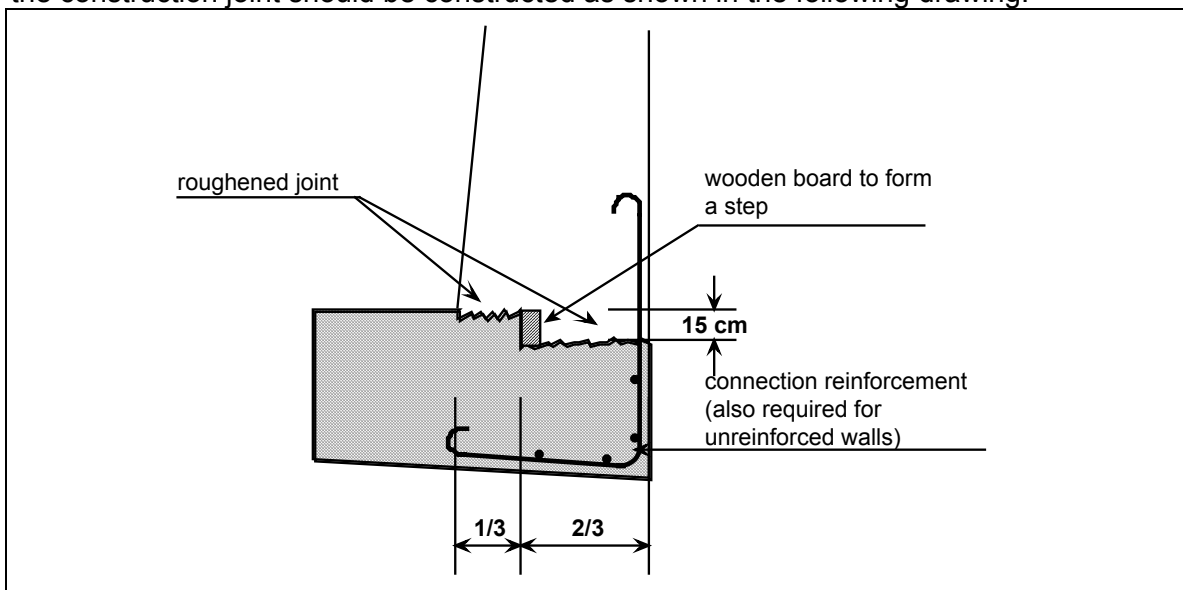

Before the wall is cast on top of the foundation the wooden board needs to be removed and the roughened joint to be cleaned and wetted. Before the first layer of wall concrete is added, a thin layer (approximately 2 to 3 cm) of a mixture of 1 (cement) : 2 (sand) has to be uniformly filled onto the joint. This “fat” mixture allows for a better bond between the foundation and the wall.

G.7.3 Joints for Retaining Walls

For retaining walls horizontal and vertical joints may be required:

Horizontal joints are normally only necessary as construction joints for high retaining walls which cannot be cast in one casting process, e.g. if the wall is higher than 300 cm (the maximum filling height for concrete is 300 cm). Such construction joints must be constructed horizontally on the same level and, if possible, exactly along a joint of timber boards of the form work as shown in the drawing below:

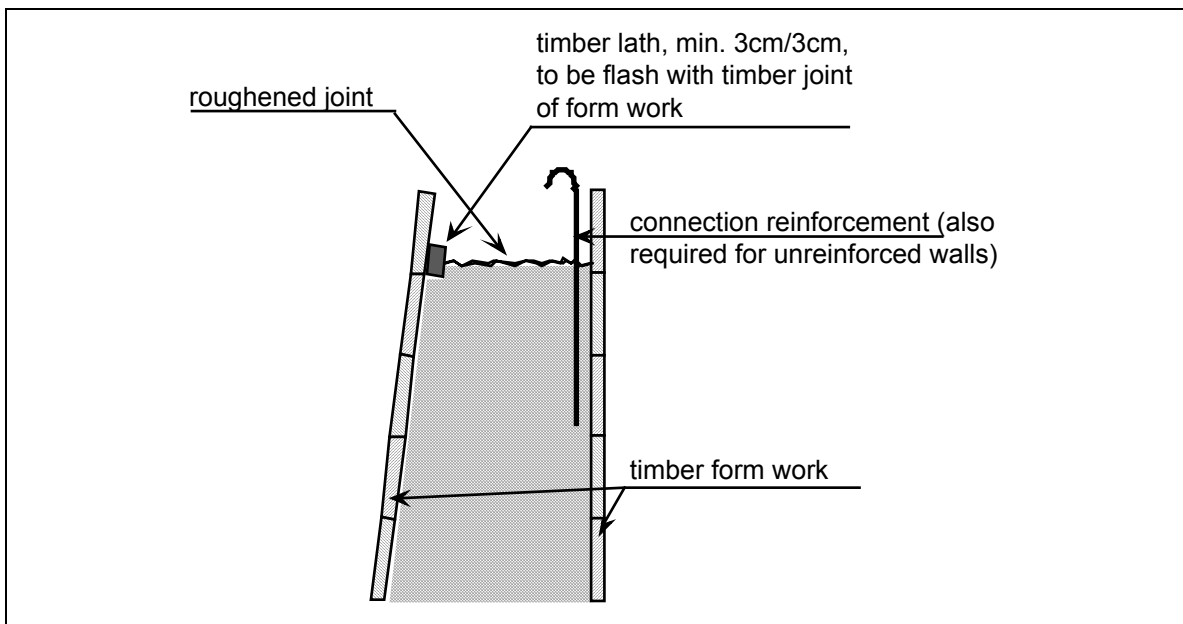

Vertical Joints are necessary either as construction joints or as dilatation joints. In principle, dilatation joints must go vertically through all wall elements, which means right from the foundation to the crown of the wall. Two basic types of joints are possible: i.) Smooth joints, which allow the neighbouring wall elements to move independently, and ii.) Interlocking joints, which do not allow the neighbouring wall elements to move individually. The detailed design of the dilatation joints must be provided by the Engineer. The drawing below shows the two principle joints only:

Smooth Joint:

Interlocking Joint:

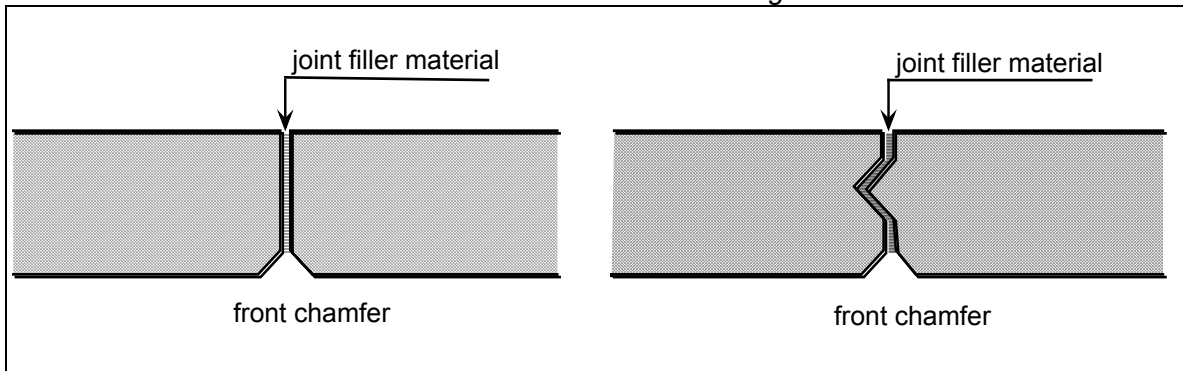

G.7.4 Joints for Floor/Deck Slabs

Slabs for drifts are often quite large and it is not always possible to cast them in one day. It is then necessary to arrange for proper construction joints. These can be planned before the work starts and the required arrangements made. However, it is always possible that the concrete casting work gets unexpectedly interrupted and an “accidental joint” needs to be made. The construction method is for both joint types basically the same and it is therefore advisable to have the necessary material (timber boards, wooden lath 3cm/3cm plus connecting rods) at site to be ready at any time. The drawing below shows the principle method for constructing the joint:

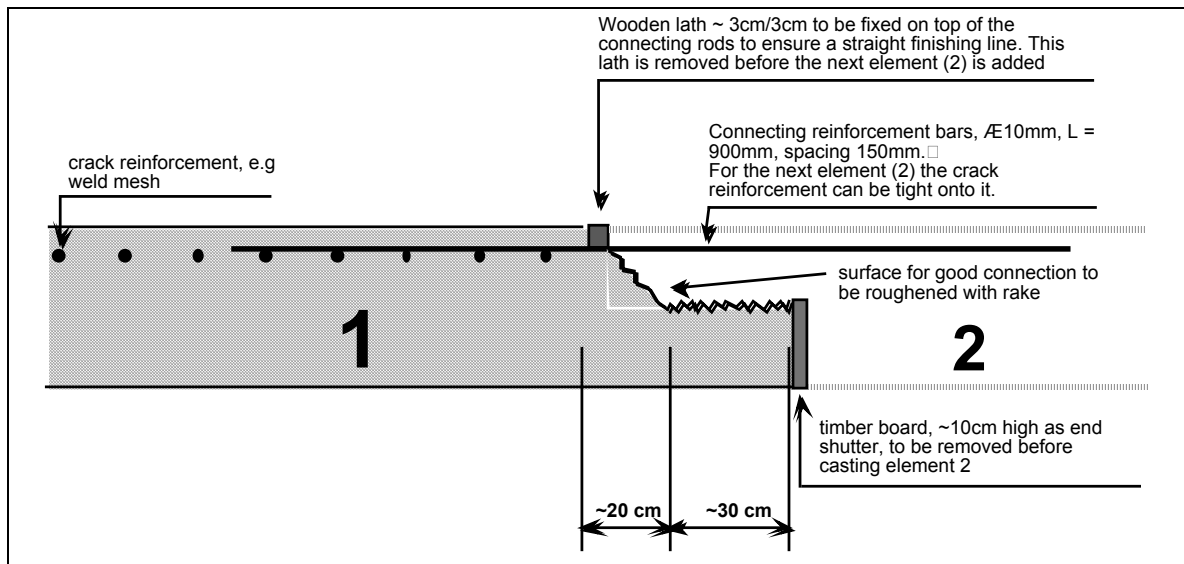

Before the next concrete slab element (2) is added to the previous one (1), the timber board and the lath must be removed, the concrete surface must be completely cleaned and the connecting rods must be tight to the reinforcement bars or the weld mesh of the second element. If the concrete is not compacted with a vibrator, then a connecting cushion of approximately 2 cm to 3 cm comprising of a mixture of 1 (cement) : 2 (sand) must be added onto the interlocking edges before the concrete work of element (2) can start.

G.8 CURING CONCRETE

Concrete hardens with water as a result of the hydration of the cement. If the concrete surfaces are not protected against drying out, the water content will drop below the amount required for complete hydration. The result is weakened concrete with cracks. It is, therefore, necessary to keep the concrete surfaces continuously wet for at least 7 days (better 14 days). This can be achieved by:

- sprinkling water on concrete surface, taking care to keep a permanent wet surface,
- covering the concrete surface with either empty cement bags, or sand or sawdust (minimum 5 cm layer). These covers must also be kept continuously wet, and
- wooden formwork for walls can be loosened a bit, left in place and regularly flooded with water.

G.9 REMOVAL OF FORMWORK

The time limit for removing the formwork should be indicated in the contract specifications. If this is not the case **request the Engineer to provide written instructions.**

A general rule of thumb:

- **Formwork for walls can be removed = after 48 hours**
- **Formwork for reinforced bearing slabs with span up to 5 metres = after 20 days.**
- **Formwork for reinforced bearing slabs with span exceeding 5 metres = after 28 d.**

G.10 QUALITY CONTROL FOR CONCRETE WORKS

CONCRETE TESTS

- (i) Type of tests:
Check on the suitability of the material for concrete making and the strength of the cured concrete. Unlike most other tests, the client carries out these tests in the laboratory. However, the Site Supervisor has to ensure on site that he/she achieves the required specifications. Continuous control mechanisms and simple site tests ensure good quality work.
- (ii) Methods used:
(see table below)
- (iii) Rectification measures:
Adjustment of batching volumes and mixing water for every major concrete operation.

Test Item	Method	Location	When?
M1.) Sand purity and grading	visual	quarry supplier	before procurement
M2.) Aggregate purity + grading	visual	quarry supplier	before procurement
M3.) Water purity	visual, if req. Lab-test	site	always
M4.) Cement age and condition	production date + visual inspection	at supplier's and at site	when buying and using
P1.) Mixing (batching) place	visual identification	site	before project
P2.) Identification of concrete type	check specifications	contr. docs. and drawings	for every concrete job
P3.) Weather conditions	visual	site	- ditto -
F1.) Batching volumes	box 40x30x30cm	site	start of project
F2.) Mixing arrangements	counting batches and water	site	always
F3.) Mixing time (3' dry, 3' wet)	count	site	always
F4.) Mixture (consistency and plasticity)	hand moulding, slump test	site	for every concrete job
F5.) Casting time limit	1 hour	site	always
F6.) Compaction (vibration)	- fill layers of max. 30cm height - cement milk passing joints	site	always
F.7.) Curing	keep wet	site	always for min. 15 days

Legend: M = Material Tests, P = Preparation Tests, F = Fabrication Tests

MODULE H:

STONE MASONRY WORK

H.1	Introduction	H-1
H.2	Materials for Stone Masonry (cement bound)	H-1
H.3	Mortar	H-1
H.4	Quantities	H-2
H.5	Stone Masonry Work	H-3
H.5.1	Foundations	H-3
H.5.2	Construction of Walls	H-3
H.6	Dry Stone Masonry (without mortar)	H-4
H.7	Brick and Block Masonry Work	H-5
H.8	Quality Control for Mortar	H-7

H.1 INTRODUCTION

This module provides some basic guidelines for stone masonry work applicable for simple road structures, like:

- culvert head and wingwalls,
- drifts
- arch culverts
- small bridges
- retaining walls

These guidelines apply for construction of minor works only, while designs for masonry in major structural works may require further specifications. This should be detailed in the contract specifications and drawings. If such relevant construction details are not mentioned, you need to contact the Engineer and ask for the required specifications in writing.

H.2 MATERIALS FOR STONE MASONRY (cement bound)

Sand:

Clean building sand, the same as for concrete. Check cleanliness with bottle test (see module G. Concrete).

Cement:

The same as for concrete (see module G. Concrete).

Water:

The same as for concrete (see module G. Concrete).

Stones:

It is important to choose only good stones to build walls. The following cannot be used:

- weathered stones
- cracked stones
- small stones (longest side smaller than 20cm)

Always choose stones whose shape is as near as possible to a rectangular prism. Stones must be free of dust and dirt. It is therefore advisable to wash them and, if necessary, clean them with a brush.

H.3 MORTAR

Mortar for road structures is a mixture of cement, sand and water. The mortar binds the stones together. The strength of the bond depends on factors such as:

- the amount of cement used,
- the amount of water used,
- the type and quality of sand,
- the quality of workmanship.

Mixing Proportions:

Construction Type	Mixture (Cement : Sand)
not bearing walls; stone lining, minor walls	1 : 7
small retaining walls; head and wingwalls, retaining walls up to 1 m height	1 : 6
bearing walls; walls for structures, retaining walls higher than 1 m	1 : 4

Note: always check in the contract specifications for the required mortar grade or mix. Consult the Engineer when you are in doubt or where it is not specified and ask for written instructions!

Mixing:

The mixing procedure for mortar is the same as for concrete (see guidelines G.4.2).

➔ The **Water-Cement** ratio (see guidelines G.4.3) should be approximately 0.4 to 0.5, which is equal to: **20 litres to 25 litres of water per bag of cement**

➔ **Rules of thumb for mortar for stone masonry:**

- The consistency should be such that it does not flow out of the trowel.
- The mortar can be kneaded in the hand and retains its form.
- The quantity of mortar to be mixed should not be more than a mason can use within one hour.

H.4 QUANTITIES

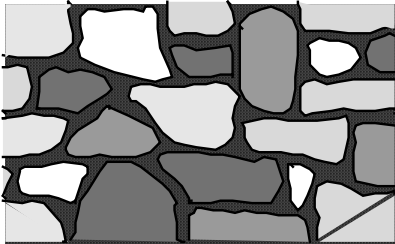
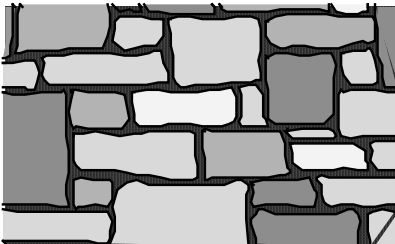
Masonry Type	Approximate Width of Joints	Requirements for 1 m ³ of Finished Wall
 <p>Rubble stone masonry; the stones are not specifically cut or shaped. To build a wall with proper bonding using rubble stones requires well-developed skills from a mason.</p>	1 cm to 4 cm	<p>Stones: approx. 1.3 to 1.5 m³ (includes waste)</p> <p>Mortar: 300 to 400 lt./ m³</p>
 <p>Shaped stone masonry; the stones are shaped to a rectangular prism. Using these stones it is easier to produce a wall with proper bonding and uniform surface.</p>	1 cm to 2.5 cm	<p>Stones: approx. 1.2 m³ (includes waste)</p> <p>Mortar: 200 to 300 lt./ m³</p>

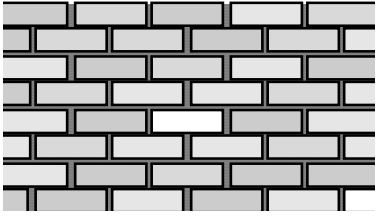
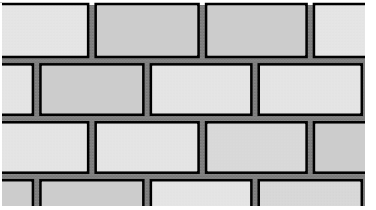
	<p>Brick masonry; bricks can be of various sizes and can be laid in many different bonds</p>	<p>1,2 cm to 1.5 cm</p>	<p>Bricks: approx. 1.1 m³ (includes waste)</p> <p>Mortar: 250 to 270 lt./m³</p>
	<p>Block masonry; blocks can be of various sizes. Blocks may be of different material, e.g. burned clay, concrete, sand-cement, etc.</p>	<p>1,2 cm to 2 cm</p>	<p>Blocks: approx. 1.1 m³ (includes waste)</p> <p>Mortar: 200 to 250 lt./m³ (depending on the size of the blocks)</p>

H.5 STONE MASONRY WORK

H.5.1 Foundations

Foundations for **bearing walls** are usually made of reinforced concrete and need to be appropriately designed by the Engineer and specified in the contract specifications and drawings.

For **minor walls** up to 150 cm in height, which do not support a heavy weight, no special concrete foundation is required. However, some principle guidelines apply as follows:

- depth underground = minimum 40 cm, on firm uniform ground
- 5 cm lean concrete (1 : 4 : 8) as a base
- the first course (footing course) should be laid with the largest and straightest stones since the stability of the wall depends largely on the bearing of the stones on the ground

H.5.2 Construction of Walls

Joints:

- for rubble stone masonry = 1 cm to 4 cm
- for shaped stone masonry = 1 cm to 2.5 cm

No stone should touch another but should be fully laid into mortar

Bond:

The bond should allow a minimum overlap of 1/4 length of the smaller stone (see sketch next page). Most of the stones are laid as stretchers. Headers, or through stones, should be laid at regular intervals to bond the two faces of the wall together. The bond stones should cover at least 2/3rds of the wall thickness and their overlap should not be less than 10 cm.

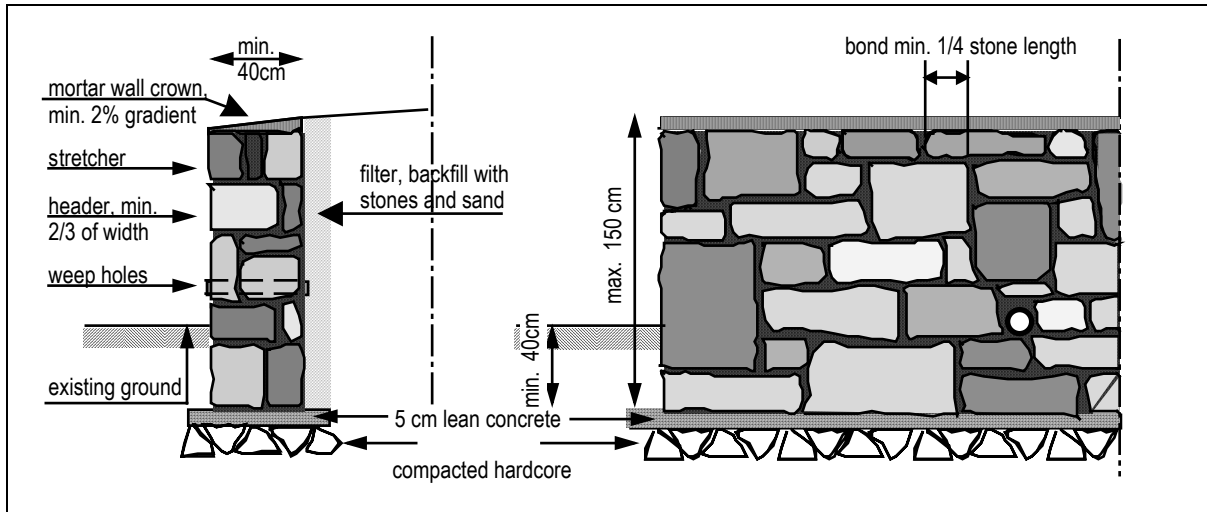

- Rules for quality construction:**
- Construct a proper foundation
 - Use only stones which are not cracked and weathered
 - Clean all stones with water and brush
 - Stones need to be wet before laying to ensure good connection with the mortar
 - Use the largest stones for the bottom layer and the corners of the wall to ensure stability
 - Use mortar of the correct mixture and consistency
 - Ensure proper bonding and joints
 - Keep the wall crown wet (use wet sacks or sand) and protect the wall from direct sun impact for at least one week to ensure proper curing

H.6 DRY STONE MASONRY (without mortar)

Dry stone masonry may be applicable for walls, which do not have to carry loads. However, they have to withstand the earth pressure with their own weight and it is therefore necessary to ensure that they are “heavy” enough. Some practical construction guidelines are shown in the drawing below.

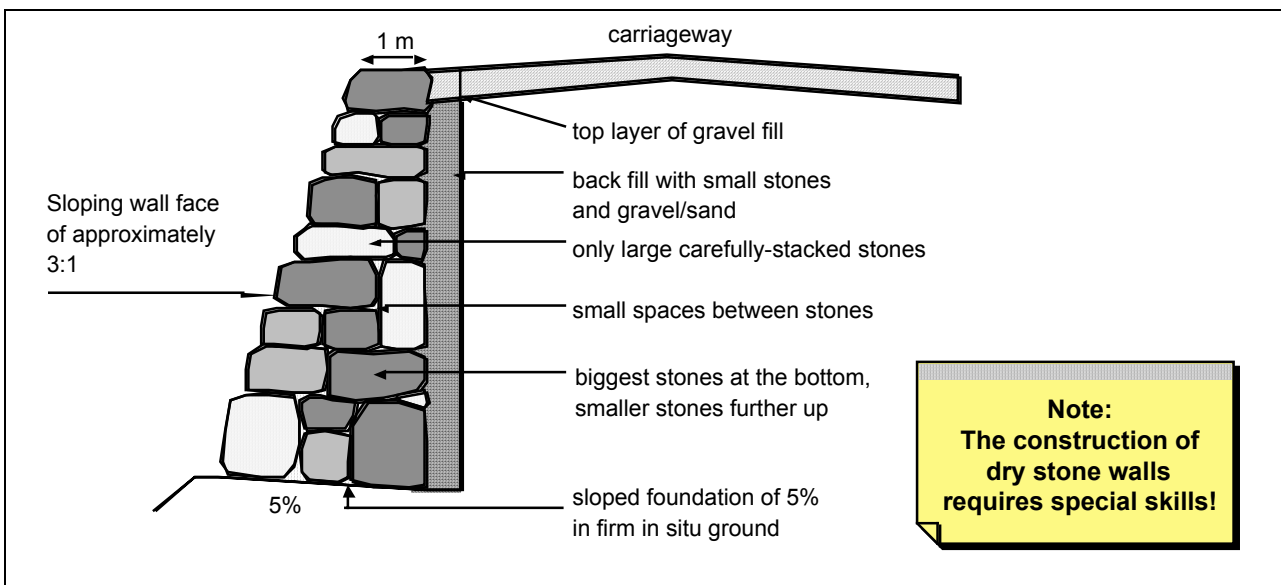

H.7 Brick and Block Masonry Work

Foundations:

Foundations for **bearing walls** are usually made of **reinforced concrete** and need to be appropriately designed and specified in the contract specifications and drawings.

For **minor walls**, which do not support a heavy weight, foundations (footings) can also be **made with bricks or blocks** and serve the same purpose as concrete foundations.

11. depth underground = minimum 40 cm, on firm uniform ground
12. 5 cm lean concrete (1 : 4 : 8) as a base

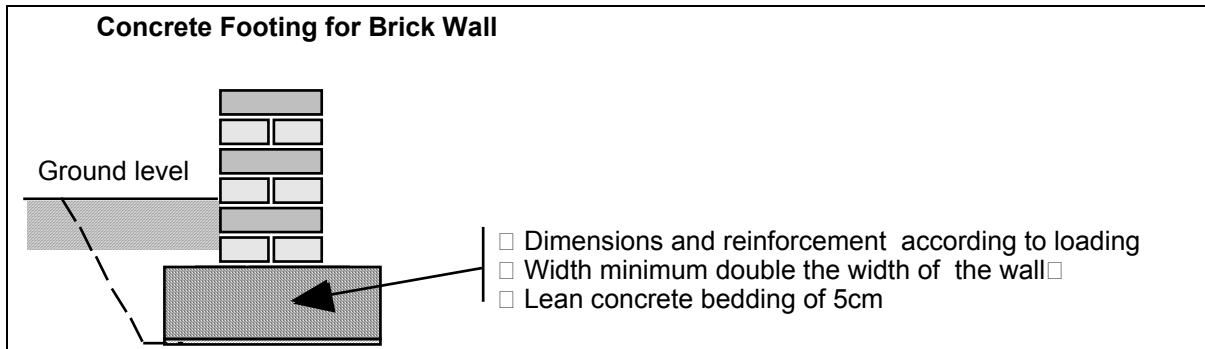

As a rule of thumb brick or block foundations should be **twice as wide as the actual wall thickness on the lowest wall course**. Each course of the foundation is reduced in regular 1/4 offsets on each side until the actual wall thickness is reached:

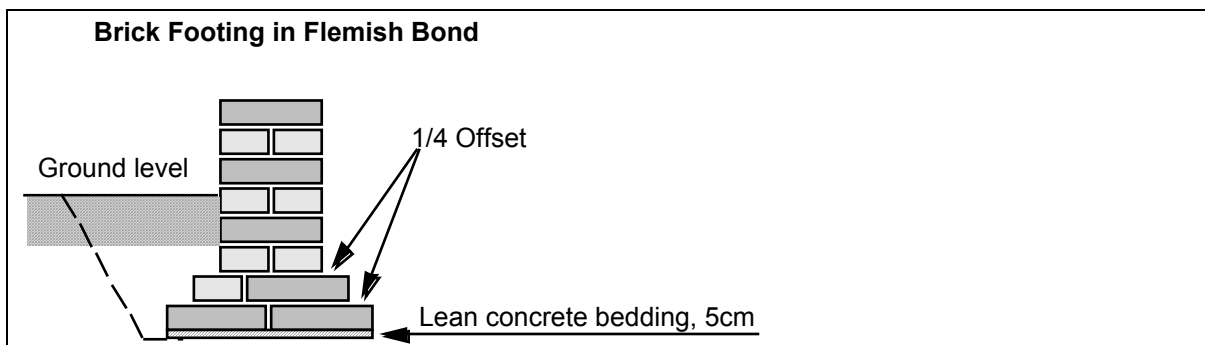

Joints:

7. for brick masonry = 1,2 cm to 1,5 cm
8. for shaped stone masonry = 1,2 cm to 2.0 cm

Bond:

Bricks can be laid in very many different bonds. However, for the purpose of public infrastructure works the bond must be practical and easy to construct. Therefore, only two different bonds are recommended, specifically the “**Stretcher Bond**” and the “**Flemish Bond**”.

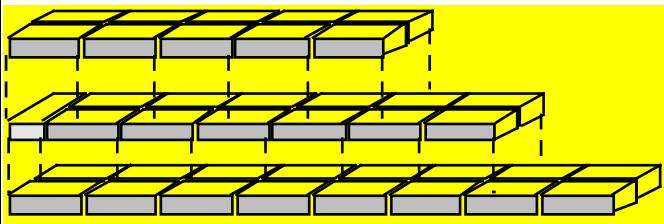
STRETCHER BOND

Stretcher

1 Header, Stretcher

Stretcher

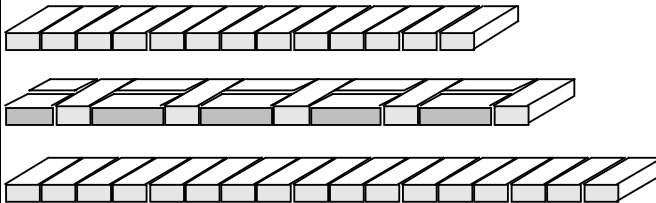
FLEMISH BOND

Header

3/4 Stretcher / Header / Stretcher /
Header

Header

Common Masonry Tools:

- Tape measure
- Square
- Plum bob with string
- Mason string
- Spirit level
- Line level and/or hosepipe (for transferring levels)
- Straight edge
- Trowels, various shapes and sizes depending on the work
- Masonry hammer, various sizes and shapes depending on the work
- Chisels, various sizes and shapes, e.g. flat and pointed
- Wheelbarrow and/or mortar basin
- Floats, wooden and steel, various sizes depending on the work
- Protection goggles, helmet and protective gloves (mainly for stone masonry)

Rules for quality brick and block masonry construction:

- **Construct a proper foundation.**
- **Use only bricks which are not cracked and from the same supplier.**
- **Bricks need to be moistened before.**
- **Use mortar of the correct mixture and consistency.**
- **Before you start building the wall always lay first two courses “dry” (without mortar) to find out the correct bonding.**
- **Ensure proper bonding and joints.**
- **For every course check for plumbness of the corners and levels.**
- **Keep close watch on the size of the joints.**
- **Finish the joints and clean the brickwork as you go along.**
- **For civil works only flush joints are required (pointed, concave, recessed, raked, etc. joints are only used for buildings as decorative measure → costly, have no particular structural purpose)**
- **Keep the wall crown wet (use wet sacks or sand) and protect the wall from direct sun impact for at least one week to ensure proper curing**

H.8 Quality Control for Mortar

MORTAR TESTS			
<p>(i) Type of tests: Checks on the suitability of the material for mortar making and the strength of the cured mortar. Unlike most other tests, the client carries out these tests in the laboratory. However, the Site Supervisor has to ensure on site that he/she achieves the required specifications. Continuous control mechanisms and simple site tests ensure good quality work.</p> <p>(ii) Methods used: (see table below)</p> <p>(iii) Rectification measures: Adjustment of batching volumes and mixing water for every major concrete operation.</p>			
Test Item	Method	Location	When?
M.1.) Sand purity and grading	visual	quarry supplier	before procurement
M.3.) Water purity	visual, if req. laboratory	site	always
M.4.) Cement age and condition	production date + visual insp.	at supplier and at site	when buying and using
P.1.) Mixing (batching) place	visual identification	site	before project
P.2.) Identification of mortar type	check specifications	Contract document and drawings	for every masonry job
P.3.) Weather conditions	visual	site	- ditto -
F.1.) Batching volumes	box 40 x 30 x 30cm	site	start of project
F.2.) Mixing	counting batches – mix 3x dry , 3x wet	site	always
F.3.) Mixture (consistency and plasticity)	- hand moulding - grove “V” test with trowel	site	for every masonry job
F.4.) Usage time limit	set time limits = 30 minutes	site	always
F.5.) Curing	keep wet	site	always for min. 7 days

Legend: M = Material Tests, P = Preparation Tests, F = Fabrication Tests

MODULE I:

CULVERT PRODUCTION

I.1	Introduction	I-1
I.2	Manufacturing Facilities and Resources	I-1
I.3	Casting	I-1
I.4	Stripping and Curing	I-2
I.5	Loading, Transport and Off-Loading	I-2

I.1 INTRODUCTION

Where unreinforced culverts are used for cross drainage purposes the rings should be cast locally at a suitable site where water, sand and aggregate are available. Ideally, the casting should be carried out at the site camp as this reduces transport costs and breakage. A skilled artisan should be in charge of the casting site to ensure that good quality work is achieved.

In order to maintain good quality, the guidelines for concrete technology in Module G should be applied. For more details refer to the Technical Manual for Labour Based Road Rehabilitation (MOWS), Chapter H-2, Concrete Technology.

I.2 MANUFACTURING FACILITIES AND RESOURCES

- A concrete platform (lean concrete) for mixing and casting, if possible covered by a simple shed (can be dismantled and used on the next site). The size of the platform is determined by the number of rings to be cast every day and the minimum curing requirement of one week before culvert rings can be moved.
- A small store for cement.
- Sufficient water storage capacity.
- Simple bays to stockpile sand and aggregates.
- A storing place for the finished culvert rings.
- A ramp for loading the culvert rings onto a lorry or trailer.
- Steel culvert moulds (usually Ø 60 cm and/or Ø 90 cm).
- Handtools (shovels, trowel, float, watering can, wooden hammer, steel bar, spanner for mould bolts, wheelbarrows, etc.).
- If available, a concrete mixer.
- Skilled artisan and labourers (recommended productivity 1.5 to 2 rings / day / person).

I.3 CASTING

- The moulds must be clean (to be cleaned immediately after casting and after stripping).
- Apply a thin film of used engine oil mixed with diesel (1 : 2) with a brush to the inside of the moulds.
- Install the culvert moulds. Ensure that the inner and outer rings are carefully centred to ensure even thickness of the concrete ring. Allow for sufficient working space around the moulds.

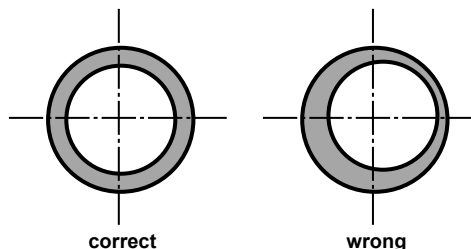

- Mix concrete, either by hand (as described in Module G, Concrete Technology) or using a mixer, if available.

For high quality rings a mix of 1 : 1.5 : 3 is recommended. Should the required strength not be achieved then the cement content may be increased to a mix of 1 : 1.5 : 2.

- Fill the ready concrete mix in equal layers of approximately 15 cm into the moulds. Compact by tamping with a steel-rod and by carefully pounding the moulds with a wooden hammer.
To simplify the pouring and minimise waste, a circular wooden board of suitable size can be placed over the inner mould. The concrete can be heaped onto this board and evenly distributed into the mould.
- Finish the culvert top immediately using the float. Clean the mould thoroughly inside and outside as long as the spilled concrete is still wet.
- Cover the top of the finished rings with either used cement bag paper, some moist sacks or plastic sheets.
- The theoretical quantities of materials required for casting one ring of 1.0 metre length (according to concrete class used) are:

	CONCRETE CLASS 20			CONCRETE CLASS 25		
	RING DIAMETER			RING DIAMETER		
	450mm	600mm	900mm	450mm	600mm	900mm
CONCRETE VOLUME (m³)	0.08	0.14	0.28	0.08	0.14	0.28
CEMENT (50kg Bag)	0.48	0.84	1.68	0.58	1.02	2.04
SAND (m³; loose)	0.034	0.059	0.118	0.030	0.053	0.106
AGGREGATE (m³; loose)	0.067	0.118	0.235	0.061	0.106	0.213

I.4 STRIPPING AND CURING

- The moulds should not be removed for at least 24 hours. Remove the moulds very carefully to avoid damaging the rings.
- Clean the moulds immediately and oil them ready for reuse.
- The concrete rings should not be moved for at least one week (7 days).
- **Important:** Keep the new rings wet and protected from direct sunshine. This can be done by retaining the rings under the sunshade and by covering them with sacks, which must be sprinkled from time to time to keep them constantly moist. Do not move the rings during this period at all.
- Allow at least for three weeks of storage (including the week where the curing is carried out) before the rings are transported to the construction site. If possible also keep the rings during this period protected from direct sunshine and ensure that they are kept wet.

I.5 LOADING, TRANSPORT AND OFF-LOADING

- Load the rings by rolling them carefully over an earth or removable wooden ramp onto the vehicle. Place the rings standing onto a cushion of sand or saw dust.
- Fill old tyres or wooden planks between empty spaces to avoid the rings from damaging each other and from tipping over. Instruct the driver to drive slowly on rough roads.
- The rings must be carefully off-loaded using ropes, wooden planks or old tyres. Off-load as close as possible to the culvert site and avoid rolling rings as much as possible.



- Un-reinforced culverts can perform very well provided they are laid carefully onto a compacted culvert bed and adequately covered with backfill material. Backfill should be done in well compacted layers of about 15 cm. The **thickness of the cover must be at least 3/4 of the internal ring diameter**: For Ø 60 cm culverts = min. 45 cm cover, for Ø 90 cm culverts = min. 68 cm.
- **Consult the Engineer if the specifications for culvert placing are not clear or if the backfill would create a hump on the road.**
- For concrete pipes manufactured on site the concrete mixture ratio for cement : fine aggregate : coarse aggregate is 1:1.5:3.
- Under ideal conditions in a well-established production yard, the mix ratio might be reduced to 1:2:4.
- Culvert moulds should be oiled, placed on a horizontal base and well centred prior to casting of rings.
- Culvert moulds should be stripped without causing damage to the fresh concrete rings and must be cleaned immediately thereafter.
- Fresh concrete rings should remain at the casting place for 7 days and require curing and protection from sunshine.
- Rings may be transported to site 28 days after manufacture.
- Occasionally haunching, e.g. with cement stabilised laterite (1 : 10), is specified in the contract.



For quality control measures refer to Module G. Concrete Technology.

MODULE J:
TRAFFIC CONTROL AND SAFETY

J.1	General	J-1
J.2	Standard Signs	J-1
J.3	Traffic Control	J-2







J.1 GENERAL

As a road work contractor you are directly responsible for the safety of your workers and the road users. Whenever work is being carried out on or close to the carriageway, adequate measures have to be taken to warn and protect both road users and your workers by ensuring that:

- the necessary temporary traffic signs and protection are provided and correctly located on site for the duration of the work,
- all equipment and vehicles are parked off the carriageway or behind protective barriers and signs, when not in use,
- no material is to be left in a dangerous location and that the road adjacent to the work site is kept clean and swept of any debris arising from the work,
- all excavations are protected for the benefit of all road users, equipment and workers,
- all operators are trained in the operation of their equipment,
- operators and labourers are informed of the potential risks of and procedures for working with or close to machinery,
- traffic control operations are carried out properly and that road users are not unnecessarily delayed,
- where work on the carriageway or shoulder remains unfinished overnight, then proper warning lights re to be arranged and, if necessary protected,
- all sites are to be left tidy and cleared of debris when the work is completed.

J.2 STANDARD SIGNS

The following signs should be available for traffic control on site:

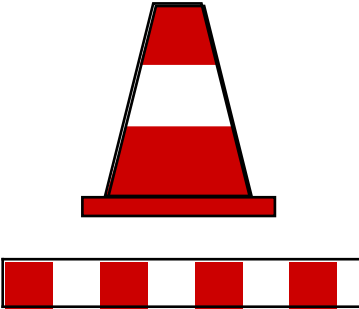
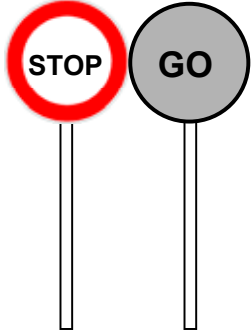
 <p>2 No. "Men Working"</p>	 <p>2 No. "Road narrows on Right Ahead" (sign may be reversed)</p>	 <p>2 No. "Turn Left" (direction of arrow may be reversed)</p>
 <p>2 No. "Keep Left" (direction of arrow may be reversed)</p>	 <p>2 No. "Road Clear"</p>	 <p>2 No. "Speed Limit"</p>
 <p>2 No. "No Overtaking"</p>	 <p>20 No. traffic cones 2 lane closure barriers</p>	 <p>2 No. reversible stop/go signs</p>

J.3 TRAFFIC CONTROL

To protect your labourers who work on the road and to enable the traffic to pass unhindered the following specific safety measures are recommended:

Routine maintenance work on low traffic volume roads:

- either traffic signs "Men Working" or yellow / orange flags are to be placed on the road shoulder before and after the site where the labourers are working,
- preferably labourers should wear yellow or orange coloured safety vests or harnesses.

Rehabilitation or regravelling work on earth and gravel roads:

Wherever possible **diversions** should be established so that traffic can be directed away from the road section under rehabilitation or regravelling. Properly installed road signs, which clearly show the diversion, are essential and the road or road section under work needs to be blocked by adequate barriers and signals.

After the diversion has been completed and before work starts, warning signs, barriers and cones must be placed around the work area. Signs must be placed in the following order:

- "Men Working" signs should be placed 200 metres in front of the work area.
- "Turn Left/Right" arrows should be placed 100 metres in front of the work area.
- **Cones** should be placed diagonally across the road to lead into the diversion.
- "Keep Left/Right" arrows should be placed at the ends of the lines of cones.
- **Barriers** should be placed behind the lines of cones.
- "End of Restriction" signs should be placed beyond the ends of the diversion
- At **night** yellow lamps should also be used to mark the extent of the work at the diversions.

Sign posting for diversions:

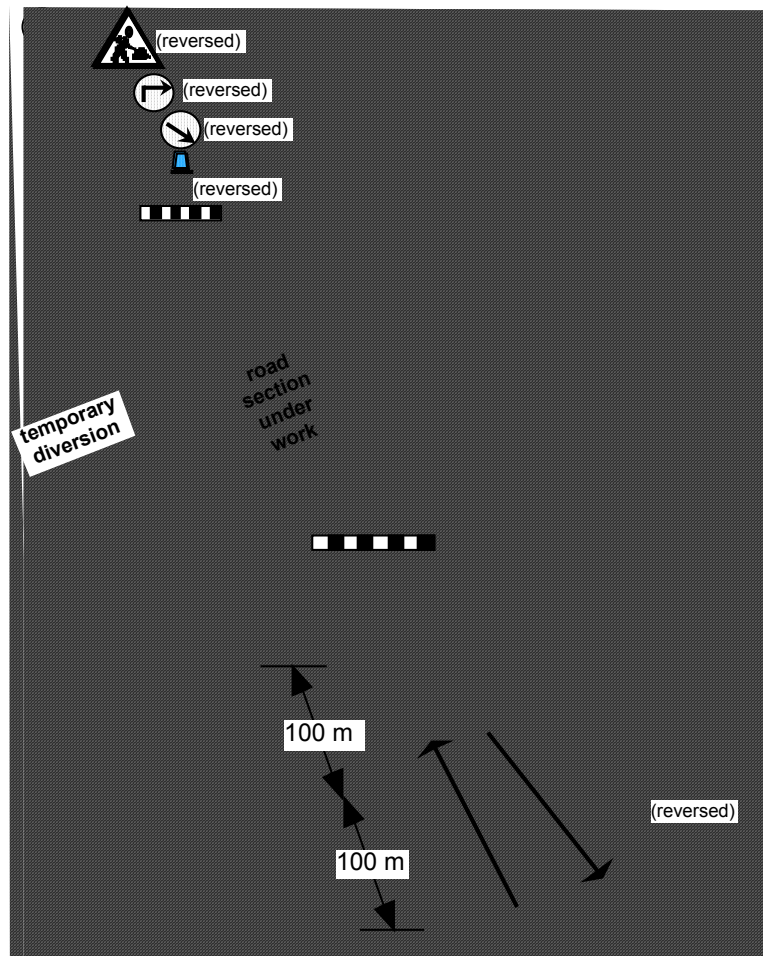

However, very often it is not possible to divert traffic as the road network is not dense enough and the construction of diversions is too expensive. Therefore, roads are to be kept open to traffic. Work should be carried out on one side of the road at a time allowing traffic to pass on the other. Before work starts, warning signs, barriers and cones must be placed around the work area.

Signs must be placed in the following order:

- **"Men Working"** signs should be placed 200 metres in front of the work area,
- **"Road Narrows"** signs should be placed 100 metres in front of the work area,
- **"Speed Limit"** signs should be placed at the start of the work area,
- **Barriers** should be placed at each end of the work area
- **Cones** should be placed in a taper at the approaches to the work area and at a maximum spacing of 10 metres along the middle of the road next to the work area.
- **"End of Restriction"** signs should be placed 50 metres beyond the work area.

Sign posting for diversion of traffic to one side of the road:

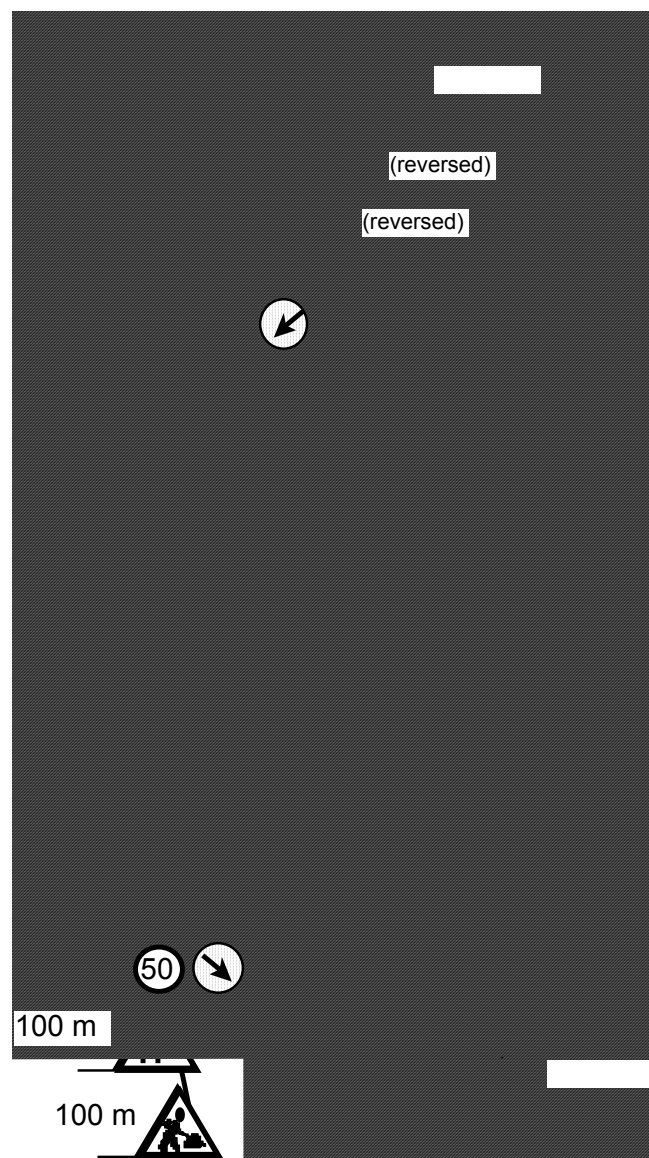

➔ For Labour Issues, Safety and Health on Site, please refer to Module P

MODULE K:

ROAD MAINTENANCE

K.1	Introduction	K-1
K.2	Common Maintenance Terms	K-1
K.3	Maintenance Operations and Activities	K-5
K.4	Management for Routine Maintenance Work	K-7
K.4.1	Management Cycle	K-7
K.4.2	Organising Routine Maintenance Works	K-7
K.5	Routine Maintenance Activities for Drainage of Paved and Unpaved Roads, Carriageway of Unpaved Roads	K-10
K.6	Routine Maintenance For Carriageway of Paved Roads	K-24

K.1 INTRODUCTION

Traditionally maintenance works was carried out directly by the road owners, mainly government departments and municipalities. Through the recent restructuring efforts of the government and with it the public service, more and more infrastructure work is contracted out to the private sector while the government retains the role of the enabler and controller. Maintenance of **roads becomes increasingly a business opportunity for local consultants and contractors**. Maintenance contracts are usually relatively small in terms of turnover and are long-term in nature. Large-scale contractors may not find this very attractive. On the other hand such contracts can be very attractive for small-scale and emerging contractors. Routine maintenance contracts over a longer period of time provide a steady income, on which a contractor can count and at the same time allow emerging contractors to enter into construction business.

Routine maintenance work is technically not too sophisticated but requires good and careful planning and control as work is spread over many locations and usually over a longer time period. However, contractors need to be fully aware of all routine maintenance activities including carriageway activities on paved road.

This Module provides guidelines for maintenance work management and implementation, specifically for routine maintenance for both unpaved and paved roads.

K.2 COMMON MAINTENANCE TERMS



For common road terms refer to Module E, Labour-Based Road Construction

Bleeding	Excess binder on the surface of the pavement.
Block Cracking	Interconnected cracks forming a series of large polygons usually with sharp corners or angles.
Corrugation	A series of ridges perpendicular to the centre line of the road and usually extend across the whole width of the carriageway.
Cracking	Narrow breaks in a surfacing or pavement material caused by overloading, fatigue or weakness of the material.
Crazing (Alligator Cracks)	Interconnecting network of cracks in the road surfacing.
Depression	Localised low areas of limited size in the pavement surface or in any other surface.
Edge Cracking	Longitudinal cracking near the edge of the pavement.
Excess Aggregate	Aggregate particles not coated with binder after application of binder.
Fretting	The loss of chippings from the surface seal or premix layer due to poor bond between the aggregate and the seal or binder.

Glazing	Wear or embedment of chippings in the surfacing giving a smooth, shiny appearance.
Pothole	A depression or hole in the road surface. Potholes are structural failures which include both the surfacing and roadbase layer. They are usually caused by water penetrating a cracked surfacing and weakening the roadbase. Further trafficking causes the surfacing to break up and a pothole develops.
Rutting	Rutting is a load associated deformation and appears as longitudinal depressions in the wheelpaths. It is the result of an accumulation of non-recoverable vertical strains in the pavement layers and in the subgrade.
Loss of Surface Aggregate	Removal of aggregate from a surface dressing, or from surfaces with coated aggregate.
Scour	Erosion of a channel bed area by water in motion, producing a deepening or widening of the channel.
Slip	Slope material sliding downhill because of instability, water penetration or flow.
Streaking	Alternate lean and heavy lines of bitumen running parallel to the pavement centre line, caused by blocked or incorrectly set spray nozzles.
Stripping (Ravelling)	The loss of surface seal from the pavement due to poor bond between the seal and the lower pavement layer.

MAINTENANCE OPERATIONS

Aggregate Brooming	Using a broom to spread chippings on a surface.
Attendant or Lengthperson	A person contracted to maintain a section of road. Can be male or female and the term "Attendant" or "Lengthperson" assumes either sex.
Compaction	Reduction in bulk of fill or other material by rolling or tamping.
Emergency (also urgent) Maintenance	Certain unforeseen situations necessitating remedial action to be taken as soon as possible e.g. flood damage, slips.
Fog Seal	A very light film of binder sprayed onto a road to bind or enrich the surface.
Pass	A single longitudinal traverse made by a grader, roller or other piece of equipment working on the road.
Patching	The execution of minor local repairs to the pavement and shoulders.
Periodic Maintenance	Operations that are occasionally required on a section of road after a period of a number of years. They are normally large scale and require specialist equipment and skilled resources to implement, and usually necessitate the temporary deployment of those resources on

the road section. These operations are costly, require specific identification and planning for implementation, and often require design.

Road Maintenance	Suitable routine, periodic and urgent activities to keep pavement, shoulders, slopes, drainage facilities and all other structures and property within the road margins as near as possible to their as-constructed or renewed condition. Maintenance includes minor repairs and improvements to eliminate the cause of defects and avoid excessive repetition of maintenance efforts.
Routine Maintenance	Operations required to be carried out once or more per year on a section of road. These operations are typically small scale or simple, but widely dispersed, and require skilled or un-skilled manpower. The need for some of these can be estimated and planned on a regular basis e.g. vegetation control.
Sanding	Spreading coarse sand onto a bituminous road surface that is bleeding.
Scarifying	The systematic disruption and loosening of the top of a road or layer surface by mechanical or other means.
Slurry Seal	A mixture usually containing fine graded aggregates, water, bitumen emulsion, cement and sometimes an additive, spread on the road surface by a specially equipped machine, or by hand.
Surface Dressing	A sprayed or hand applied film of bitumen followed by the application of a layer of stone chippings, which is then rolled.
Urgent (also Emergency) Maintenance	Certain unforeseen situations necessitating remedial action to be taken as soon as possible, e.g. flood
Wind Row	A ridge of material formed by the spillage from the end of the machine blade.

MAINTENANCE PLANT AND EQUIPMENT

4WD	Four Wheel Drive vehicle or equipment.
Aggregate Silo (Hopper)	Storage container for aggregate which is fed from the top and emptied from the bottom.
Bitumen Heater-Distributer Truck	A truck with an insulated tank and heating system designed to apply a bituminous binder at an even and uniform rate of spread.
Drag	An apparatus towed behind a vehicle or piece of equipment to remove minor irregularities and redistribute loose surface material.
Grader	A self-propelled or drawn machine that cuts soil in thin layers and spreads it evenly. For maintenance usually used to reform the camber and smoothen the gravel or earth surface.
Gritter	A self-propelled machine or an apparatus fitted to the back of a tipper truck, to spread chippings in a controlled and constant rate of spread.
Hoist	A hydraulic, mechanically or manually operated lifting device.

Hopper	The body of a road-paving machine into which the premixed materials are tipped prior to spreading.
Mechanical Broom	Motor-operated rotary broom used to sweep loose material and objects from the pavement surface, usually attached to a tractor.
Mixing Plant	Mechanical plant designed to grade and mix mineral aggregates and binder to produce premix material.
Patching Vehicle	A specialist truck equipped with a bitumen tank of about 2000 litres capacity, with or without heater, cover for personnel, hopper for aggregate, and handspray lance.
Paver-Screed-Plate	A levelling device with a flat bottom mounted at the rear of the paver, which strikes off the fresh premix at the desired thickness and provides some initial compaction to the mix.
Ramps	Timber or steel planks for loading and unloading small items of equipment.
Road Paver	A self-propelled or tractor-drawn machine designed to evenly spread and partially compact aggregate mixtures.
Spray Lance	Apparatus permitting hand-application of bituminous binder at a desired rate of spread through a nozzle.
Squeegee	A small wooden or metal board with a handle for spreading bituminous mixtures by hand.

MATERIALS

Aggregate	Hard mineral elements of construction material mixtures, for example: sand, gravel, crushed rock.
Asphalt	Sometimes used to describe plant mixed bituminous materials. See also Bituminous Binder.
Asphaltic Concrete	A high quality manufactured mixture of bitumen and aggregates.
Bituminous Slurry (Slurry-Seal)	Mixture, usually of fine-grained aggregates, water, bituminous binder (emulsion), cement, and sometimes an additive, for a road surface seal.
Bituminous Binder, Asphalt	A petroleum oil based or natural product used to bind or coat aggregates for road pavements.
Bitumen Emulsion	Bitumen dispersed in small particles in water. Emulsion is made in a special plant. When used, the emulsion 'breaks', whereby the water separates from the bitumen and leaves the bitumen to function as the binder.
Chippings	Clean, strong, durable pieces of stone made by crushing or napping rock. The chippings are screened to obtain material in a small size range.
Gabion	Stone-filled wire or steel mesh cage. Gabions are often used as retaining walls or riverbank scour protection structures.

Sand Mixtures	Sands of different gradings, mixed to provide the required material for a bituminous mixture.
Sod	As Turf but with more soil attached (usually more than 10cm).
Tar Binder	A binder made from processing coal.

K.3 MAINTENANCE OPERATIONS AND ACTIVITIES

Maintenance operations have to be carefully planned and adjusted to the actual requirements. Maintenance contracts are actually allocated in accordance with the basic maintenance operations. The three main operations are:

- **ROUTINE MAINTENANCE:** Operations required to be carried out once or more per year on a section of road both for paved and unpaved roads. These operations are typically small scale or simple, but widely dispersed, and require skilled or unskilled manpower. The need for some of these can be estimated and planned on a regular basis e.g. vegetation control.
- **PERIODIC MAINTENANCE:** Operations that are occasionally required on a section of road after a period of a number of years. They are normally large scale and require specialist equipment and skilled resources to implement, and usually necessitate the temporary deployment of those resources on the road section. These operations are costly and require specific identification and planning for implementation, and often require design.
- **EMERGENCY MAINTENANCE:** Certain unforeseen situations necessitating remedial action to be taken as soon as possible, e.g. flood.

It is necessary to identify these maintenance operations to be able to:

1. Set priorities and plan maintenance work,
2. Organise maintenance work,
3. Quantify maintenance work,
4. Estimate maintenance work for funding purposes,
5. Instruct maintenance work to the maintenance personnel.

The operations are divided into single work activities. Common activities may be determined as per the following tables:

Typical Routine Maintenance Activities for Unpaved Roads

Inspection and removal of obstacles

Cleaning of drainage structures and their inlets and outlets (culverts, splashes, etc.)

Repair of culvert headwalls, approaches and aprons of splashes, etc.

Repair of culvert drains/off-shoot drains/catchwater drains and excavation to original sizes

Cleaning of side drains and excavation to original size

Filling of potholes in carriageway

Repair of shoulder and slope erosion

Light reshaping of carriageway (camber formation, corrugation, ruts, etc.)

Maintenance of erosion controls in drains

Cutting of grass on shoulders and side drains

Clearing bush

Typical R

Inspection and removal of obstacles

Cleaning of drainage structures and their inlets and outlets (culverts, splashes, etc.)

Repair of culvert headwalls, approaches and aprons of splashes, etc.

Repair of culvert drains/off-shoot drains/catchwater drains and excavation to original sizes

Cleaning of side drains and excavation to original size

Cleaning of catchwater drains and excavation to original size

Patch and reshape shoulder (gravel shoulder)

Patch surface edge

Patch potholes, (including patching of local severe ruts/depressions)

Seal cracks

Sand off bleeding areas

Bush clearing and grass cutting

Typical Periodic Maintenance Activities

Heavy reshaping of road or road section (by labour, drag, towed grader)

Installation or reconstruction of small drainage structures

Rehabilitation of road or road section

Rehabilitation of major structures (bridges, drifts)

Reshaping and regravelling/resealing of road or road section

Provision of gravel stacks along the road to be used for routine maintenance activities

Typical Emergency Maintenance Activities

Reconstruction / repair of culverts (washouts, erosion or breakage)

Reconstruction / repair of structures (washouts, erosion, damage from high floods)

Clearing of landslide, tree fall or rock-fall.

Reconstruction / repair of a road section (washout or serious erosion)

Reconstruction / repair of drainage systems (serious silting up or erosion)

Reconstruction / repair of erosion protection (serious washout, landslide, etc)

This module deals with routine maintenance activities only. For re-gravelling (gravelling) details refer to Module E. For road safety details refer to Module J.

K.4 MANAGEMENT OF ROUTINE MAINTENANCE WORK

K.4.1 Management Cycle

All maintenance operations require careful planning, supervision and monitoring. The maintenance management cycle shows the required activity phases in the logical sequence

Maintenance contractors are not involved in phases 1 to 3. For the preparation of tenders however, a contractor will be involved in phase 4 by preparing maintenance workplans. Phase 5 consists of the actual contract work.

Also phase 6 is part of contract work implementation:

- The client requires information on the quality and quantity of work carried out by contractors.
- The contractor requires information on resources actually spent and productivity rates achieved.

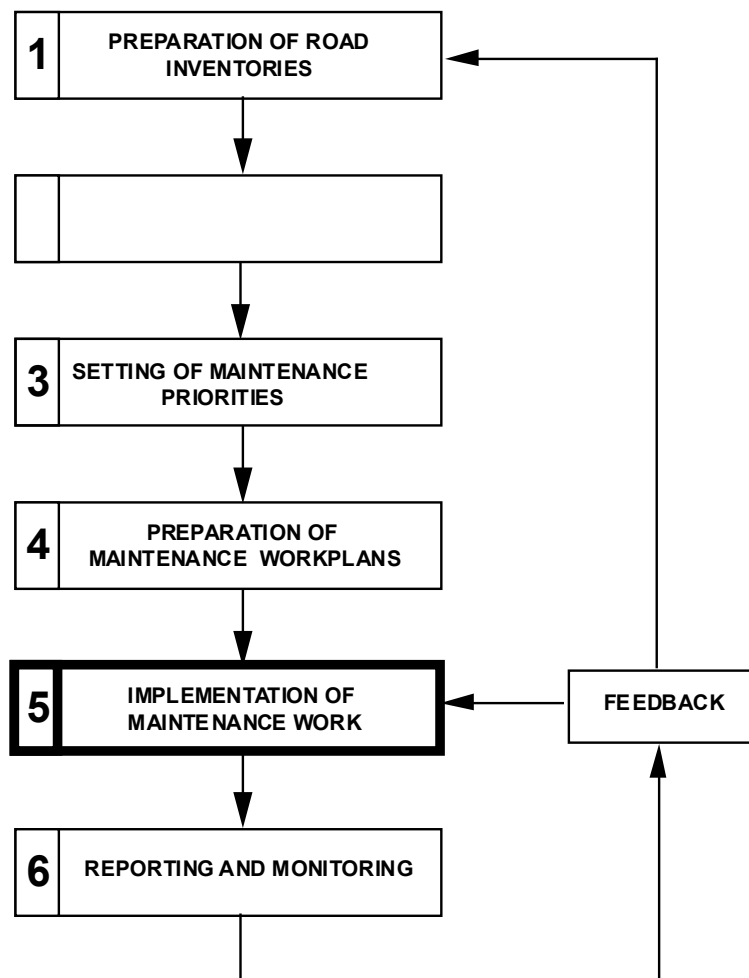

K.4.2 Organising Routine Maintenance Works

Site Inspection:

Before preparing a tender the site must be inspected to collect important data such as:

- Existing condition of road.
- Condition survey of client as compared with contractor's own assessment.
- Availability of skilled and unskilled labourers.
- The local leaders and authorities from whom support/co-operation is required.
- Transport distance to site.
- Mode of transport required for work and supervision.
- Traffic details and weather conditions.

Organising the Site Routine maintenance on a road or road section can be carried out using different ways of organising works. The two alternatives are:

- **Lengthperson:** A labourer is appointed for a distinct section of road, typically 1 to 1.5 km in length. He or she is provided with all the necessary handtools to carry out all the routine maintenance activities as instructed by the contractor. The *advantage* is that a continuous maintenance of the entire road can be guaranteed at all times and one person can be made fully responsible of a road section. Labourers living next not the road can be effectively utilised. This alternative may be particularly suitable for performance contracts. The *disadvantage* is that supervision has to be spread along the whole contract length. A supervisor has to visit all road sections and labourers individually and therefore has to be mobile.
- **Gangsystem:** A gang of labourers may consist of up to 20 labourers and is directly supervised by a gang supervisor. The gang works along the road, section by section, and carries out all activities. The *advantage* is that supervision can be concentrated and planning of the work is easier. The *disadvantage* is that no continuous maintenance of the whole road section under contract is possible. Another disadvantage is that labourers often have to walk long distances until they reach the work site.

Transport: Transport is required for the contractor (ideally a pick-up) to supervise works and to transport tools or small amounts of material. The Gang Supervisor may also require transport, especially if work is organised using the Lengthperson system. A bicycle or a motor cycle is usually ideal.

Common Tools:

For each labourer:

- Hoe
- Grass cutter
- Shovel
- Bush knife
- Rake or spreader

For sharing:

- Wheelbarrows
- Earthrammers
- Long handles shovels and spikes to clean culverts
- Bush saw

For Supervisor:

- Tape measure
- Ditch template and/or straight edge and spirit level
- Strings and pegs

Requirements for Activities on Bitumen Surface (Bitumen Emulsion) Minimal requirements for pothole patching, crack sealing and slurry sealing are:

- Pick-up (transport of tools, roller, sprayer, premix)
- Emulsion sprayer pump
- Pedestrian vibrating roller or vibrating plate
- Pick axes
- Shovels and bitumen rakes

- Wheelbarrow
- Brooms
- Watering cans
- Drum of diesel oil for use in cleaning the spray lance*, and other tools,
- Spare jet for the spray lance,
- Box of tools for use in dismantling the spray lance,
- Rags, Hessian (for slurry seal)
- Squeegees
- Handhammers
- Paint brushes,
- Metal bucket,
- Two-metre straight edge,
- Chalk for marking.

Planning and Reporting

The overall plan is the workplan as stipulated in the contract. For execution this plan has to be broken down into smaller plans for instruction and supervision purposes. This is best done by using **Weekly Instructions and Reports** (see form below).

Besides this form, it is important to maintain a proper labour record in the form of a Musterroll. This form is also used for paying labour wages (see sample form in Module N).

COMPANY: <u>TECHNOPLUS</u>		GANGLER'S INSTRUCTIONS			ROUTINE MAINTENANCE	
ROAD NAME: <u>BONOKI - MARUBA</u>		ROAD NO: <u>E22</u>	GANG REF. <u>E22/1</u>	GANGLER'S NAME: <u>Jacob Ondieki</u>		
INSTRUCTION FOR WEEK: <u>No6 (4.7. - 8.7.95)</u>		BY: <u>Peter Foreman</u>		DATE OF INSTRUCTION <u>3.7.95</u>		
GANG SIZE: <u>8</u> NO		WORKING DAYS THIS PERIOD: <u>3</u> NO		TOTAL WORKER DAYS AVAILABLE: <u>24</u> NO		
A		B		AxB = C		
ACTIVITY	LOCATION FROM -- TO G	PLANNED WORKER DAYS D	TASK RATE E	PLANNED OUTPUT DxE = F	ACHIEVED WORKER DAYS H	ACHIEVED OUTPUT K
<i>Inspection and Removal of Obstructions</i>	<i>0.000 - 17.000</i>	<i>1</i>	<i>-</i>	<i>-</i>	<i>1</i>	<i>-</i>
<i>Clean Culverts</i>	<i>0.000 - 17.000</i>	<i>4</i>	<i>2No</i>	<i>8No</i>	<i>4</i>	<i>7No</i>
<i>Clean side Drains</i>	<i>0.000 - 17.000</i>	<i>13</i>	<i>50m</i>	<i>650m</i>	<i>12</i>	<i>600m</i>
<i>Repair Scour Checks</i>	<i>0.000 - 17.000</i>	<i>1</i>	<i>5No</i>	<i>5No</i>	<i>1</i>	<i>5No</i>
<i>Cut Grass</i>	<i>0.000 - 17.000</i>	<i>5</i>	<i>350m2</i>	<i>1750m2</i>	<i>5</i>	<i>1750m2</i>
TOTAL WORKER DAYS		planned	24	achieved	23	

K.5 ROUTINE MAINTENANCE ACTIVITIES FOR DRAINAGE OF PAVED AND UNPAVED ROADS, CARRIAGEWAY OF UNPAVED ROADS



- The following Activity Sheets provide practical guidelines and checklists for common routine maintenance activities for the drainage of paved and unpaved roads as well as routine maintenance of carriageway of unpaved roads.
- The Activity Sheets are meant to be used as reference when preparing tenders, for developing work-plans, for instructing and training on site as well as for supervision and monitoring of ongoing work.
- For the purpose of instructing and training the site cadre, it is therefore advisable to make copies of the Activity Sheets.

The activity sheets are grouped as per the Routine Maintenance Specifications of the Ministry of Supply, Roads Department:

Activities for Drainage of Paved and Unpaved Roads, Carriageway of Unpaved Roads

RM1 Inspect and remove obstacles

RM2A Clean culverts

RM2B Repair erosion in culvert inlets, outlets and discharge drains

RM3 Clean mitre drains

RM4A Clean side drains

RM4B Repair side drain erosion

RM5 Repair scour checks

RM6 Repair shoulder, side slope and back slope erosion

RM7 Repair potholes

RM8 Reshape carriageway and repair ruts and gullies

RM9 Repair culvert

RM10 Control vegetation

RM11 Grub edges of carriageway and shoulder

Activity Sheet

RM1**INSPECT AND REMOVE OBSTRUCTION****Standard Specification:**

Carriageway and ditches to be clear form any obstructions and debris

Work Definition:

Inspection of the section of the road and removal of any obstruction and debris form the carriageway and ditches (only what can be removed on the spot which poses immediate danger to the traffic)

Seasonal Priority:

Just before rains (1) / Rainy season (2) / Just after rains (3) / Dry season (4)

Work Method:

- Walk along the road/section, check all road features, drainage structures and road furniture
- Remove on the spot any obstruction form the carriageway and ditches within your capacity and dispose of well clear of the drainage systems
- For other job requirements found during the inspection assign resources (labour, tools, etc.) and carry out as described in respective activity sheets.

Special Considerations:

- Report to traffic police for any broken down vehicle on the carriageway
- Report any missing or broken traffic signs to Roads Department

Tools and Equipment:

- Axe
- Bush knife (panga)

Material:

- Strings
- Pegs

Safety Signs and Devices

- Safety Vest

Suggested Productivity Range:

Inspection = 8000 – 10,000 m / day / labourer

Actual Productivity:

Activity Sheet **RM2A** *CLEAN CULVERTS*

Standard Specification:

Culverts, including inlets and outlets to be clean of sand, silt and debris.

Work Definition:

- Clean all sited culverts, including inlets and outlets.
- Remove debris, silt and sand and dispose of well clear of the drainage system.

Seasonal Priority:

Just before rains (1) / Rainy season (2) / Just after rains (3) / Dry season (4)

Work Method:

- Check culvert inlets, barrel and outlets for silt, sand and debris (use torch to check barrel).
- Remove and dispose of well clear of the drainage system, preferably on the lower side of the road.
- If the culvert is severely blocked use long handled tools, like shovel and rode (iron bar 10 to 12mm, 12m long) or scoop with a bucket tied to a rope.

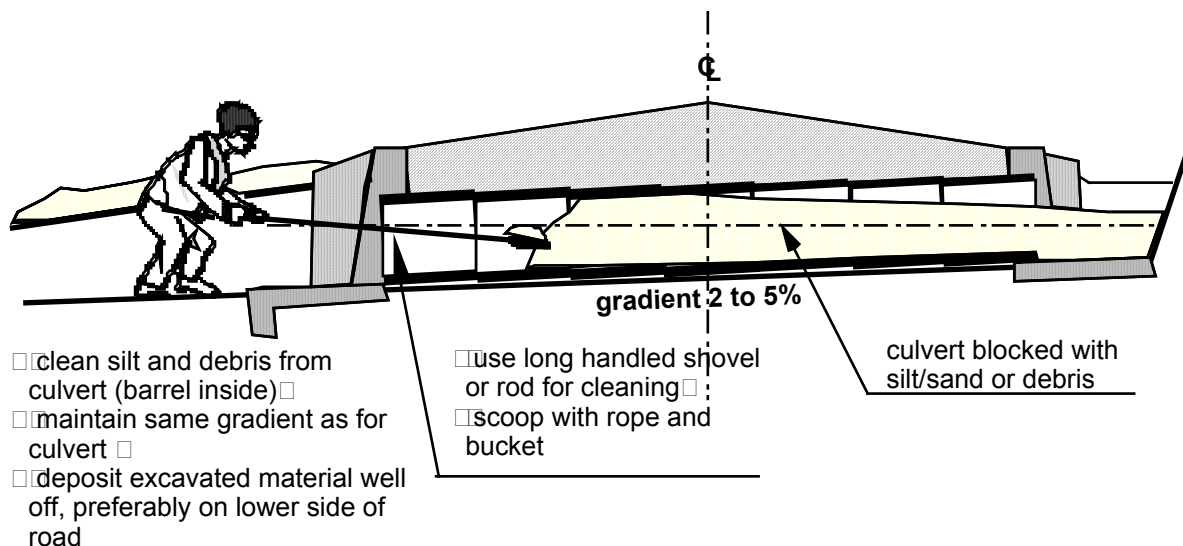

Special Considerations:

- Discharge drains which are longer than 20m have to be treated as mitre drains → RM3

Tools and Equipment:

- Torch
- Hoe and Shovel
- Long handled shovel, spike
- Wheelbarrow
- Rope and bucket
- Rod (10-12mm, 12m long bar)
- Slasher, panga and rake

Material:

Safety Signs and Devices

- Safety Vest

Suggested Productivity Range:

Cleaning = 1 to 4 culvert lines / day / labourer
(depending on blockage level and length of culvert)

Actual Productivity:

Activity Sheet **RM2B****REPAIR EROSION IN CULVERT INLETS,
OUTLETS AND DISCHARGE DRAINS****Standard Specification:**

- Inlets, outlets and drains to be free from erosion.
- Measures taken to prevent from recurrence of erosion or to prevent severe erosion, e.g. stone pitching, stone lining, scour checks, turfing, etc.

Work Definition:

- Repair erosion on inlets, outlets and discharge drains of culverts and provide erosion control measures.

Seasonal Priority:

Just before rains (1) / Rainy season (1) / Just after rains (3) / Dry season (4)

Work Method:

- Check for erosion in inlets, outlets and discharge drains.
- Excavate loose material.
- Fill with approved material, stones and selected granular material in layers and compact with hand rammer.
- Provide erosion measure if required, e.g. stone lining, scour checks, turfing, etc.

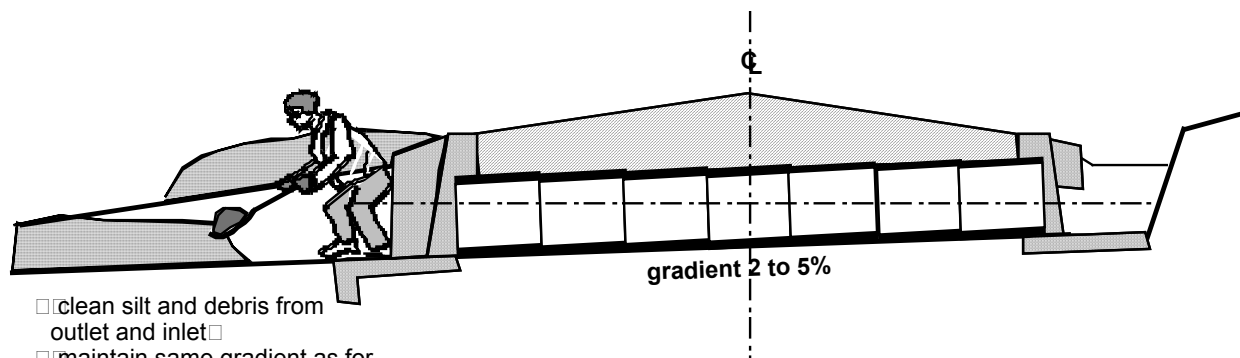

- clean silt and debris from outlet and inlet
- maintain same gradient as for culvert
- excavate outlet with a minimum width of 60cm
- repair erosion

Special Considerations:

- For erosion measures refer to technical manual.

Tools and Equipment:

- Shovel
- Hoe
- Hand rammer
- mason's tools if stone lining / pitching or masonry scour checks

Material: (for erosion control measures only)

- Sand
- Cement
- Good quality stones
- Stacks for wooden scour checks

Safety Signs and Devices

- Safety Vest

Suggested Productivity Range:

Repair Erosion = 2 to 3 m³ / day / labourer

Actual Productivity:

Activity Sheet **RM3** *CLEAN MITRE DRAINS*

Standard Specification:

Drains to be clean from silt and debris, and to have the original dimensions and gradient (minimum 1%).

Work Definition:

Remove all silt and debris from mitre drains and cut to specified depth, width and shape.

Seasonal Priority:

Just before rains (1) / Rainy season (2) / Just after rains (3) / Dry season (4)

Work Method:

- Remove all silt and debris to specified levels, gradient and shape.
- Deposit all excavated material and debris on the lower side of the mitre drain (valley side).
- Check levels and gradient and correct where necessary.

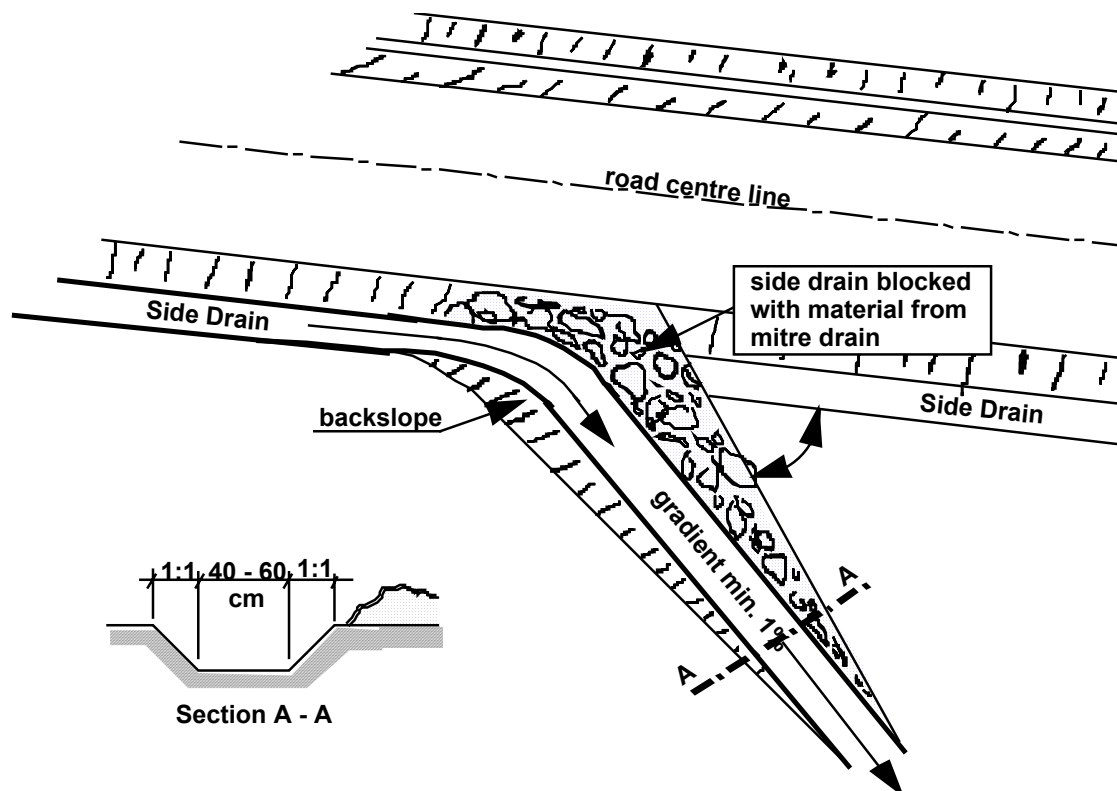

Special Considerations:

- Ensure that the block in the side drain effectively leads the water into the mitre drain (see drawing above).

Tools and Equipment:

- Shovel
- Hoe
- Pick axe
- wheelbarrow

Material:

Safety Signs and Devices

- Safety Vest

Suggested Productivity Range:

Cleaning = 2 to 3 m³ / day / labourer

Actual Productivity:

Activity Sheet RM4A CL

Standard Specification:

Drains to be clean form silt and debris, and to have the original dimensions.

Work Definition:

Remove all silt and debris form side drains and cut to specified depth, width and shape.

Seasonal Priority:

Just before rains (1) / Rainy season (2) / Just after rains (3) / Dry season (4)

Work Method:

- Check existing depth and shape of side drains using template and tape measure.
- Re-establish levels and shape at suitable intervals, e.g. cut slot every 10 metres, using template and spirit level. Set out longitudinal line using pegs and strings.
- Remove silt and debris and re-excavate to original shape.
- Throw excavated material well clear of the drain, preferably on lower side of the road.

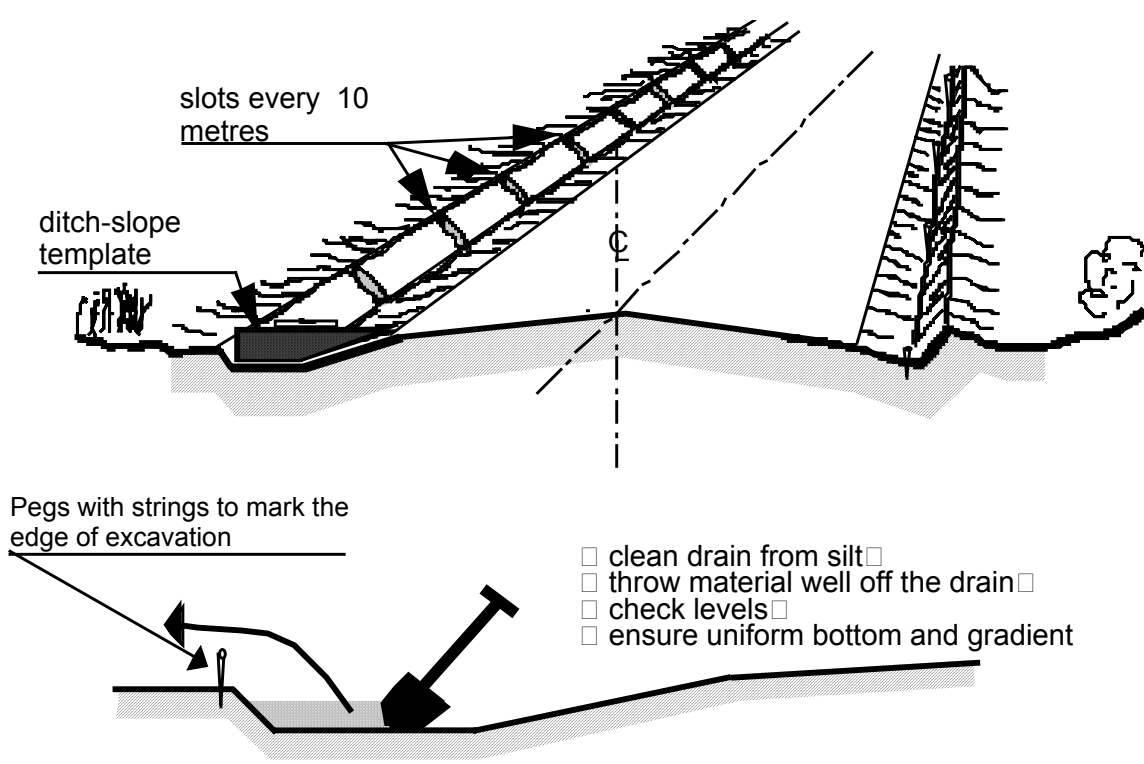

- clean drain from silt
- throw material well off the drain
- check levels
- ensure uniform bottom and gradient

Tools and Equipment:

- Shovel
- Hoe
- Pick axe
- Ditch-slope template, spirit level
- wheelbarrow

Material:

- Pegs
- Strings

Safety Signs and Devices

- Safety Vest

Suggested Productivity Range:

Cleaning = 2 to 3 m³ / day / labourer

Actual Productivity:

Activity Sheet **RM4B** *REPAIR SIDE DRAIN EROSION*

Standard Specification:

Side drains to be free from erosions and/or steps taken to prevent erosion.

Work Definition:

Repair all eroded side drains and/or carry out measures to prevent erosion.

Seasonal Priority:

Just before rains (2) / Rainy season (3) / Just after rains (1) / Dry season (4)

Work Method:

- Repair erosion by filling with suitable granular material and compact.
- Alternatively, line with stones (dry or cement bound) or plant grass.
- Repair damaged scour-checks and/or install new ones where missing (refer to RM5).

Special Considerations:

- Where erosion is severe, more scour checks may have to be constructed.
- Stone lining and pitching are good alternatives but are expensive.
- Grass planting is often a cheap alternative where the gradient is not too steep.

Tools and Equipment:

- Shovel
- Hoe
- Handrammer
- Wheelbarrow
- Ditch-slope template, spirit level
- wheelbarrow

Material:

- Granular material
- cement, sand and stones for lining
- stacks for wooden scour checks

Safety Signs and Devices

- Safety Vest

Suggested Productivity Range:

Erosion Repair = No of metres / day / labourer
(depending on degree of erosion and type of repair work)

Actual Productivity:

Activity Sheet

RM5

RE

COUR CHECKS

Standard Specification:

All damaged scour checks to be repaired to specified standard. Below scour checks drain to be free of erosion.

Work Definition:

Repair all damaged and reinstate missing scour-checks.

Seasonal Priority:

Just before rains (1) / Rainy season (2) / Just after rains (3) / Dry season (4)

Work Method:

- Check all scour-checks for damages and whether missing.
- Repair damaged scour (wooden or stone scour checks) checks including aprons and backfill with good material and compact in accordance with specifications.
- Replace missing scour checks including aprons and backfill with good material and compact.

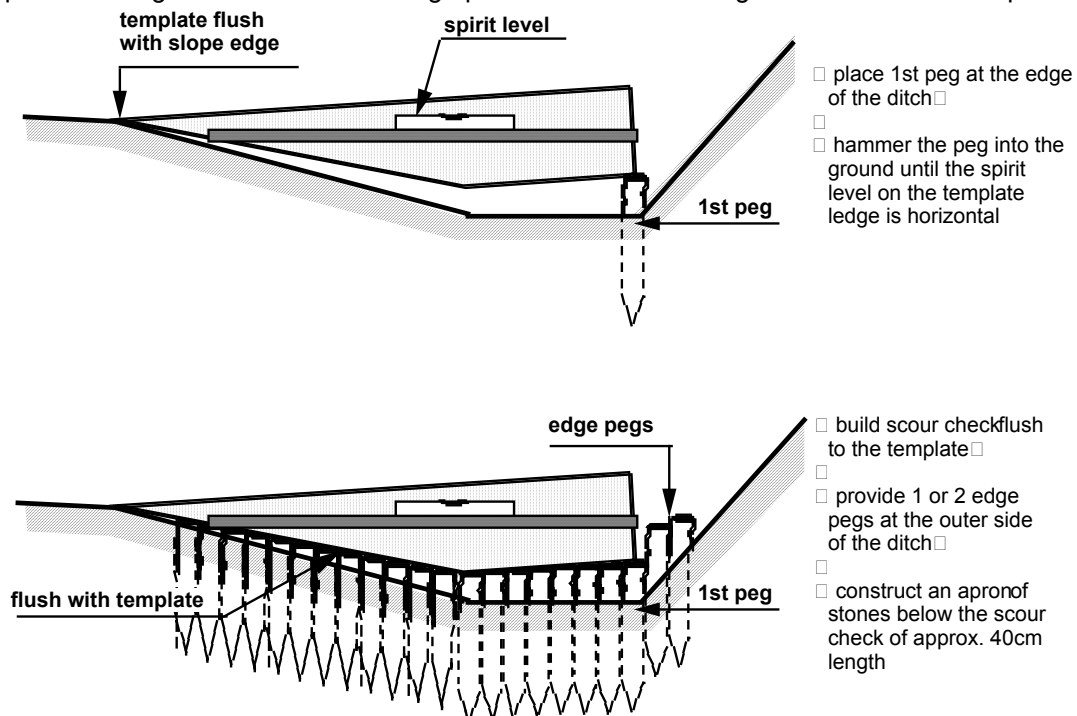
**Special Considerations:**

- Wooden scour checks only apply to earth roads and low class gravel roads.
- On higher class gravel roads and bitumen roads provide stone (or masonry) scour checks.

Tools and Equipment:

- Scour-check template with spirit level

For wooden scours checks

- Axe, bush knife
- Mattock, Sledge hammer
- Wheelbarrow

For masonry scour check

- Shovel
- Mattock or pick axe
- Mason's tools
- Wheelbarrow

Material:

- *For wooden scours checks*
 - wooden stacks (hard wood if possible)
- *For masonry scour check*
 - Cement and Sand
 - Stones

Safety Signs and Devices

- Safety Vest

Suggested Productivity Range:

Scour checks = 2 – 4 No. / day / labourer

Actual Productivity:

Activity Sheet

RM6**REPAIR SHOULDER, SIDE SLOPE AND
BACK SLOPE EROSION****Standard Specification:**

Shoulders and slopes to be free from erosion.

Work Definition:

Repair erosion on shoulders, side slopes and back slopes.

Seasonal Priority:

Just before rains (4) / Rainy season (2) / Just after rains (1) / Dry season (3)

Work Method:

- Check extent of erosion.
- Fill gullies and ruts with selected material / soil and compact.
- Plant grass along shoulder line and on slopes to avoid further erosion.
- For gravel shoulders use approved gravel for filling.

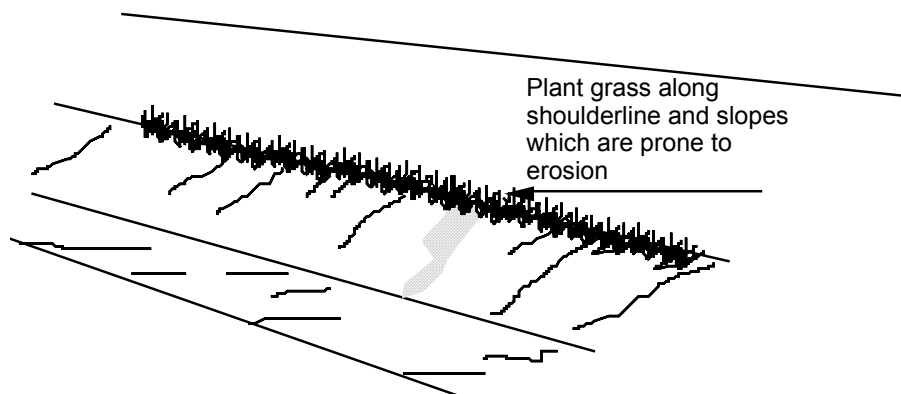
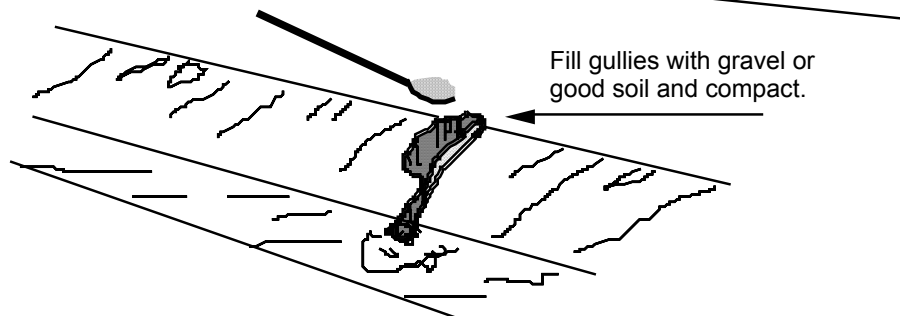
**Special Considerations:**

- For larger eroded areas on slopes broadcasting seeds of local grass and plants may be more appropriate than planting grass.

Tools and Equipment:

- Hoe
- Shovel
- Hand Rammer
- Wheelbarrow
- Slope-ditch template + spirit level

Material:

- Gravel for shoulder repair
- Grass Turf and / or grass seeds

Safety Signs and Devices

- Works Ahead" Signs
- Traffic Cones
- Safety Vest

Suggested Productivity Range:

Erosion Repair = 5 to 10 m²/ day / labourer

Actual Productivity:

Activity Sheet

RM7**REPAIR POTHOLES****Standard Specification:**

Carriageway to be free from potholes.

Work Definition:

Cut and fill with selected suitable gravel and compact.

Seasonal Priority:

Just before rains (2) / Rainy season (2) / Just after rains (3) / Dry season (4)

Work Method:

- Remove weak or soaked material from pothole dig out until firm ground/material is reached.
- Cut back to firm material in square or rectangular size.
- Wet the hole if material is dry and fill in new material in layers of not more than 10cm and compact
- Last layer to be slightly higher than the existing surface (allow for settling)

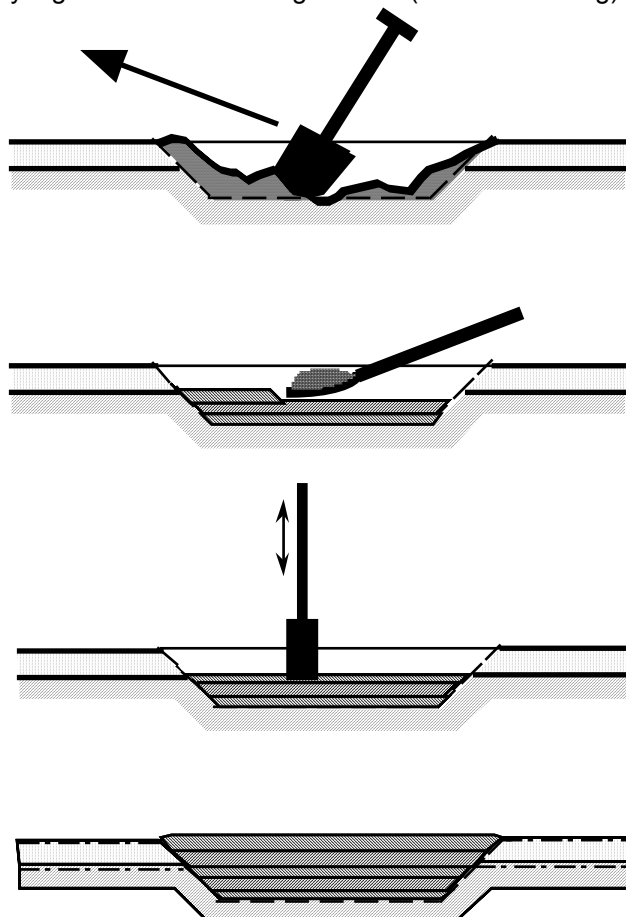
**Special Considerations:**

- Moisten fill material if dry for good compaction

Tools and Equipment:

- Pick Axe or Mattock
- Hoe and Shovel
- Hand Rammer
- Wheelbarrow

Material:

- Approved Gravel

Safety Signs and Devices

- Works Ahead” Signs
- Traffic Cones
- Safety Vest

Suggested Productivity Range:

Pothole Filling = 5 to 10 m² / day / labourer

Actual Productivity:

Activity Sheet

RM8

RESHAPE CARRIAGEWAY AND REPAIR RUTS AND GULLIES**Standard Specification:**

Carriageway to be free from wheel ruts, shoulder to be free from deformations and camber to drain.

Work Definition:

Light reshaping of carriageway by cutting and filling back dislodged material and ensuring camber can drain.

Seasonal Priority:

Just before rains (2) / Rainy season (4) / Just after rains (1) / Dry season (3)

Work Method:

- Cut shoulder to original shape and gradient.
- Fill wheel ruts and gullies with suitable gravel.
- Reshape camber by raking back dislodged material. Check gradient with camber board.
- Compact smaller fill areas with hand rammer. Larger areas may be compacted by traffic.

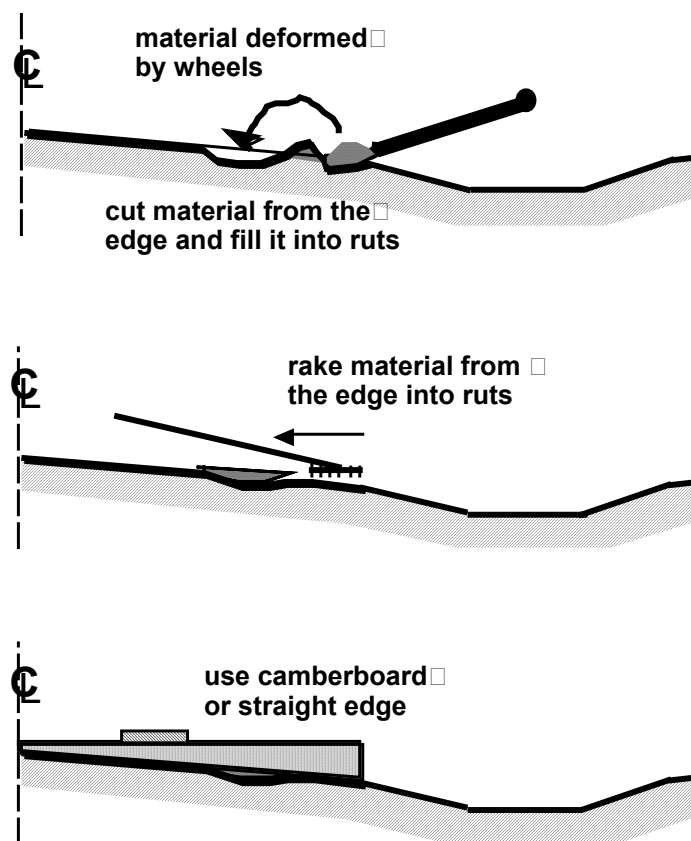
**Special Considerations:**

- Suitable material to be hauled by wheelbarrow if material from shoulders and carriageway is insufficient or of poor quality.

Tools and Equipment:

- Pick Axe or Mattock
- Hoe and Shovel
- Hand Rammer
- Wheelbarrow
- Camber Board and Spirit Level

Material:

- Approved Gravel

Safety Signs and Devices

- Works Ahead" Signs
- Traffic Cones
- Safety Vest

Suggested Productivity Range:

Erosion Repair = 5 to 10m² / day / labourer

Actual Productivity:

Activity Sheet

RM9**REPAIR CULVERTS****Standard Specification:**

All headwalls and wingwalls including aprons to be free from cracks and minor damages.

Work Definition:

Repair of culvert masonry head and wingwalls including aprons by filling cracks and replacing dislodged/missing stones.

Seasonal Priority:

Just before rains (2) / Rainy season (4) / Just after rains (3) / Dry season (1)

Work Method:

- Check headwalls and wingwalls including aprons for cracks and dislodged, missing stones.
- Fill cracks using cement mortar.
- Replace/place dislodged or missing stones with cement mortar.
- Repaint headwalls after repair if necessary.

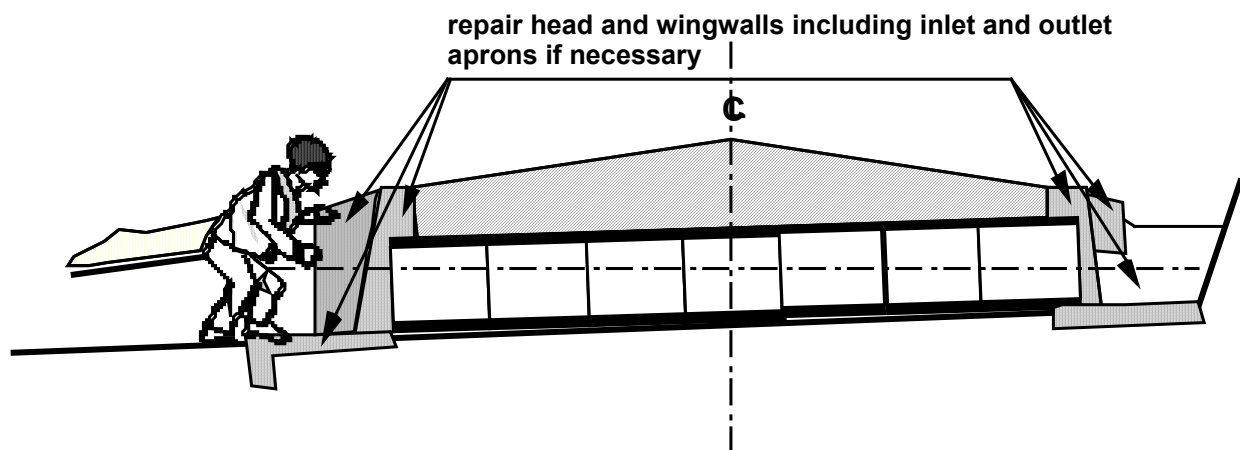
**Special Considerations:**

- For head and wingwalls with dry masonry replace dislodged stones and wedge them firmly into place.

Tools and Equipment:

- Mason's Tools
- Shovel
- Wheelbarrow
- Crowbar
- Paintbrush

Material:

- Stones
- Cement
- Sand
- Water
- Paint

Safety Signs and Devices

- Safety Vest

Suggested Productivity Range:

Daywork

Actual Productivity:

Activity Sheet **RM10** *CONTROL VEGETATION*

Standard Specification:

Road reserve, side ditch and side slopes to be free from tall grass, height not more than 5cm above ground.

Work Definition:

Cut all tall grass and shrubs within the road reserve, including shoulders, slopes and ditches and dispose of well clear of the drainage system and road reserve.

Seasonal Priority:

Just before rains (1) / Rainy season (2) / Just after rains (3) / Dry season (4)

Work Method:

- Cut all tall grass within the road reserve, including side drains, slopes and shoulders.
- Gather / rake and dispose of well clear off the drainage system.
- Do not burn the grass even after gathering.

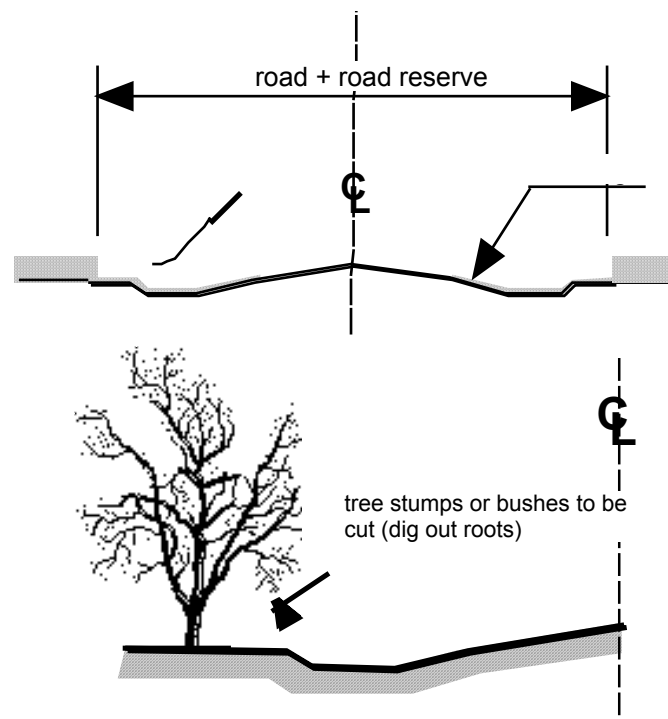
**Special Considerations:**

- Do not burn grass.

Tools and Equipment:

- Slashers
- Panga / Bush Knife / Axe
- Rakes

Material:**Safety Signs and Devices**

- "Works Ahead" Signs
- Safety Vest

Suggested Productivity Range:

Grass cutting = 100 - 300 m² / day / labourer

Actual Productivity:

Activity Sheet **RM11****GRUB EDGES OF CARRIAGEWAY AND****Standard Specification:**

Edge of carriageway and shoulder to be free from vegetation.

Work Definition:

Grub off grass tufts on carriageway edge and shoulders and remove.

Seasonal Priority:

Just before rains (3) / Rainy season (4) / Just after rains (2) / Dry season (1)

Work Method:

- Set out shoulder-carriageway line using pegs and strings.
- Grub edge using a hoe towards the slope and remove the material (grass and roots).
- Up-root bushes and young trees on shoulder.
- Gather debris with a rake and dispose well clear off the drainage system.
- Do not burn debris.

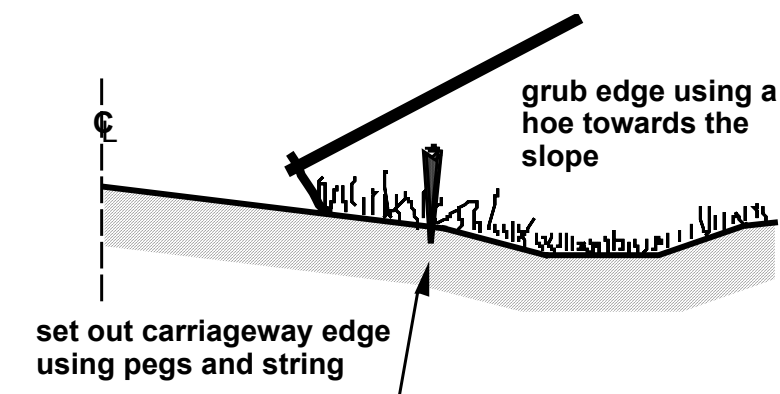
**Special Considerations:**

- Do not grub grass on the side slopes and in the ditch as the roots of the grass prevent erosion.

Tools and Equipment:

- Hoe
- Rake
- Wheelbarrow
- Shovel

Material:

- Pegs
- Strings

Safety Signs and Devices

- "Works ahead" Signs
- Traffic Cones
- Safety Vest

Suggested Productivity Range:

Grub edges = 100 – 300m / day / labourer

Actual Productivity:

K.6 ROUTINE MAINTENANCE FOR CARRIAGEWAY OF PAVED ROADS



- The following Activity Sheets provide practical guidelines and checklists for common routine maintenance activities for the carriageway of paved roads.
- The Activity Sheets are meant to be used as reference when preparing tenders, for developing work-plans, for instructing and training on site as well as for supervision and monitoring of ongoing work.
- For the purpose of instructing and training the site cadre, it is therefore advisable to make copies of the Activity Sheets.

The activity sheets are grouped as per the Routine Maintenance Specifications of the Ministry of Works and Supply, Roads Department:

Activities for Carriageway of Paved Roads	
General	Working with bitumen emulsion
Preparation	Prepare cold asphalt premix
RM12	Patch surface edge
RM13	Patch potholes, (including patching of local severe ruts/depressions)
RM14	Seal cracks
RM15	Slurry seal for localised sealing

Working with Bitumen Emulsion

The most commonly used binder for road maintenance is Bitumen Emulsion, which is in broad terms bitumen dispersed in small particles in water. The emulsion is fabricated in a special plant and is sold in bulk or in drums of 210 litres.

There are two basic types of emulsion, which are chemically different:

- **CATIONIC** → An emulsion where the **emulsifier is an acidic organic salt**. The bitumen globules carry a positive electrostatic charge. This emulsion is suitable for all types of rock.
- **ANIONIC** → An emulsion where the **emulsifier is an alkaline organic salt**. The bitumen globules carry a negative electrostatic charge. This emulsion can give poor adhesion with acidic rocks (such as granite and quartzite) but good adhesion with basic rocks (such as basalt) and with limestone. The addition of small percentage of fresh hydrated lime, or sometime cement, to the aggregate will improve adhesion to acidic rocks. Anionic emulsions are usually slower setting which is preferred for slurry seal operations.

There are three grades of anionic and cationic emulsions; **Rapid, Medium or Slow setting** and normally contain between 40 to 70 percent bitumen, 65 percent being the best for most labour-based works.

<i>Grade of Emulsion</i>	<i>Abbreviation</i>	<i>Appropriate Use</i>
Rapid setting	RS	Sand seals Surface dressing Penetration macadam
Medium setting	MS	Pre-mixed bitumen and gravel (course grading)
Slow setting	SS	Otta seal Pre-mixed bitumen and gravel (fine grading) Slurry seal

- The most commonly used bitumen concentration (in emulsions available in Zambia) is 60%.
- The code name for emulsions are based on the following principle; **K** = cationic, **A** = anionic, **1** = spray grade, **2** mix grade, **3** = stable grade, **60** = 60% concentration, **RS** = rapid setting, **MS** = medium setting, **SS** = slow setting.
An emulsion coded **K2RS60** means: a cationic emulsion of **mix grade, rapid setting** and **60% bitumen** concentration.
- Some emulsions such as slow setting grades can be diluted with water if necessary but a test on a small quantity of emulsion and water should be carried out to confirm that the quality of the water is satisfactory.
- Make sure that the **quality of water for dilution on site is checked**, and note that water for dilution of cationic emulsion must not be alkaline (i.e. PH above 7). Water is likely to be very alkaline in limestone areas. A simple way of testing the compatibility of water and emulsion in the field is to mix half a litre of water and emulsion respectively and if there is a mismatch they will separate immediately.
- When using emulsion it will soon 'break', whereby the water separates from the bitumen particles and leaves the bitumen to function as the binder. One can easily see **when emulsion breaks as it turns from brown to black**.

Never mix cationic with anionic emulsion, as an instant 'break' and a subsequent massive cleanup job is the result! Equipment/tools should therefore, be thoroughly cleaned with diesel before any interchange

- Emulsions have a **limited shelf life** as they start to separate (settle) after long time in storage. It is advisable to avoid storage in drums for longer than three months. The drums should be stored lying down under a shade and be rolled a few times when they are taken out for use.
- Emulsions containing less than 70% bitumen can be sprayed and mixed at ambient temperatures. Emulsions that contain more than 70% bitumen require heating to approximately 70°C.
- The most commonly used emulsion types in Zambia are for dry and hot weather **Anistable** or **Catmix** and for cold and wet weather **Catmix**.
- For **pothole patching and edge repairs mix grade emulsion** is the most useful.

- When procuring material i.e. emulsions and aggregate – the Provincial Road Engineer (Project Manager’s Representative) should be consulted on the type of emulsion(s) normally used in the province and where the source of aggregate is.
- Cationic emulsions are, as a general rule, more useful in rainy and cold season and anionic emulsions in hot and dry season – therefore, some countries in the region are differentiating between “summer” and “winter” mixes.
- Smaller nominal stone size in an aggregate gives a more dense mix and is less likely to allow water to seep through. However, this limits the thickness of the patch, as the recommended thickness is 2 to 4 times of the maximum stone size of the aggregate.



When preparing the coldmix as a rule of thumb the **bitumen emulsion content should be about 10% by weight**. The approximate density for an emulsion is 1 Kg/litre and for aggregate 1.5Kg/litre respectively.

- The **aggregate should not contain too many fines** when cationic emulsion is used.
- It is strongly recommended that small quantity **trial mixes** be made in the field before attempting to mix bigger quantities. It is further recommended that the contractor controls the emulsion content very carefully in order to **avoid the coldmix being too “rich”**. One way of avoiding the coldmix from becoming too rich is to **ensure that the aggregate is coated only to 80%** and not the normally specified 100%. Bitumen emulsion experts in Zambia have derived this “better practise” out of long hands-on experience.
- **Caution** – dampen the aggregate before mixing - but do not add water to the mix.
- A coldmix can be placed on the stabilised base material in a pothole immediately after the filling operation is completed. If the placing of coldmix is carried out the next day, the primed stabilised material should be swept and cleaned, or eventually receive a new coat of prime emulsion to provide a tack, before the coldmix is placed. After the coldmix has been placed in the pothole it should be sanded or spread with quarry dust to prevent pick-up on tyres.
- **Priming** of the stabilised material (used to fill the pothole) can be done with the same emulsion as that used for the coldmix. If necessary, the emulsion could be diluted with suitable water at a 50/50 ratio to improve its penetration.
- Paraffin or diesel oil should be used for cleaning of equipment, tools and containers.



Environmental concern: Bitumen is semi-solid under most conditions, is not biodegradable and is poorly soluble in water. The environmental impacts of bitumen emulsions are the same as those of normal bitumen once the emulsion has broken. Contamination of soil and water should be avoided though bitumen itself has low toxicity. However, they can contain certain solvents, emulsifiers and modifiers.

Handling precautions: – Bitumen emulsions cause irritation to skin and eyes. Therefore, skin should be thoroughly washed after any contact with emulsion, and always before going to the toilet, eating or drinking. Solvents such as petrol, diesel oil, white spirit, etc. should not be used for removing emulsion from the skin as these may spread the contamination. Use soap and warm water. Protective clothing should always be used when handling bitumen whether hot or cold mixed

Activity Sheet Preparation**PREPARE COLD ASPHALT PREMIX****Standard Specification:**

Check for exact specification in contract document or get advice from the Engineer. See also details in Section K.6, Bitumen Emulsion.

Work Method:

- Prepare clean mixing area, preferably concrete slab or steel plates.
- Heap mixing piles of 5mm aggregate in a circle around a central area, which will be used to stockpile the cold mix. Each aggregate pile equals one standard builder wheelbarrow of 60 litres (≈ 100kg).
- Dampen the aggregate but do not make it wet.
- Measure out 10 litre of emulsion, which is equal to 10Kg to be mixed with 100Kg (one pile) of aggregate (emulsion content of 10% by weight).
- Open the mixing pile and pour the emulsion onto the mixing pile. Ensure that emulsion does not run out of mixing pile.
- Mix aggregate and emulsion with 2 – 3 workers using shovels or concrete mixer until all of the aggregate is well covered with emulsion. Do not overmix.
- Spread the mix and wait for the emulsion to break. The mix will turn from brown to black in colour in approximately five minutes, if emulsion and aggregate are compatible.
- Place mix on central stockpile area and form a heaped stockpile.
- Repeat the above steps until a sufficient amount of coldmix has been prepared.
- Place a tarpaulin or other suitable material over the stockpile to protect it from weather.

Special Considerations:

- The stockpile life is approximately 3 months, however, the stockpile life varies with the mix design.
- Mixing can be done in a standard concrete mixer or by hand. The method of mixing will vary with the type of mixer:
 - (i) With a rotary drum (type concrete mixer): it is preferable to add a portion of the emulsion first, otherwise the aggregate may cling to the bottom of the bowl
 - (ii) With a none-tilt concrete mixer or a paddle mixer the aggregate may be added first.
 - (iii) The most suitable sequence for rapid mixing can quickly be determined by the contractor (trial and error method).
 - (iv) When mixing by hand the emulsion is simply poured over the batch, which is turned over with shovels until coating is complete.
 - (v) If difficulty in obtaining a uniform mix, particularly with fine graded aggregate, dampen the aggregate/dust to assist dispersion of the emulsion.
- (iv) Caution – when using concrete mixer do not over-mix as it can cause stripping of the emulsion from the larger particles of the aggregate.

Tools and Equipment:

- Concrete platform or steel plates for mixing
- Builders Wheelbarrow
- Shovel
- 10 litre measuring can
- 1 litre can (for measuring emulsion and water)
- Hand or engine driven concrete mixer (optional)

Material:

- 5mm nominal stone size aggregate
- Quarry dust (not always required)
- Cationic or anionic mix grade emulsion
- Water
- Paraffin or diesel oil (for cleaning)
- Cleaning cloth

Safety Signs and Devices**Suggested Productivity Range:**

Hand mixing = 3 – 4m³ / day / labourer
Machine mixing = depending on the mixer

Actual Productivity:

Activity Sheet **RM12** PATCH SURFACE EDGE

Standard Specification:

Edge of carriageway to be unravelled and stable.

Work Definition:

Patch edge of bitumen carriageway and repair shoulder

Seasonal Priority:

Just before rains (3) / Rainy season (4) / Just after rains (2) / Dry season (1)

Assessment of Defect:

Define the depth of the shoulder erosion and check whether the base or even the sub-base is affected.

If the base and sub-base are affected, first repair the entire shoulder including the base and sub-base and then the road edge (see method 2).

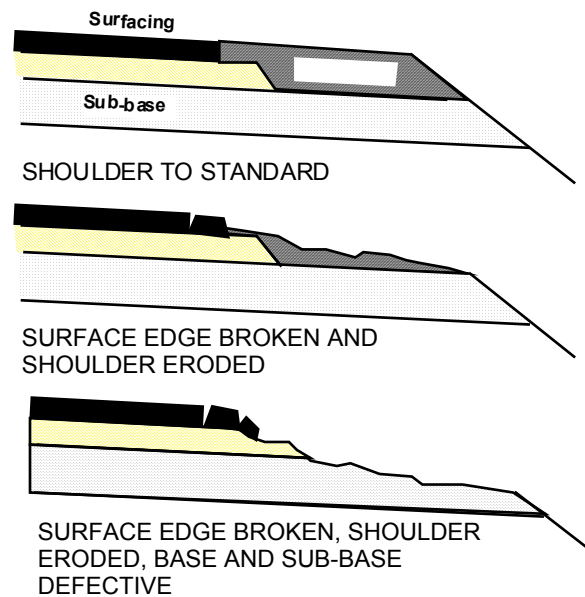

Work Method, Alternative 1:

- Dig and remove all unstable material (surface and shoulder) to the depth of the base.
- Brush out and clean the area.
- Loosen the existing shoulder gravel to allow a key for the added material.
- Add new gravel in layers of not more than 10 cm to shoulder, add water if necessary and compact with hand rammer or hand roller.
- Allow for some surplus material (level of shoulder to be slightly higher than surface) for later settlement.
- Make sure the crossfall of the shoulder is the same as for the carriageway.
- Remove any excess material for further use along the road and clear the section of debris.
- Mark out the line along the road edge to be cut. Use string line to maintain edge line. Cut a trench of about 8 cm width and 8 cm depth into the base. Make sure the sides are vertical.
- Brush out and clean the area of the excavation.

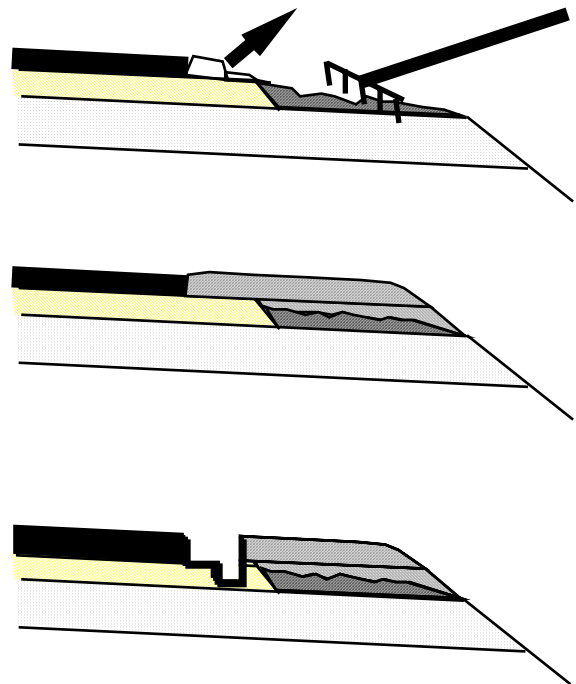

- Apply a prime coat (60% Cationic or Anionic mix grade emulsion diluted to 50/50) to the surface of the excavated area using block brush. Make sure the edges of the patch are well coated.
- Place premix carefully in the edge trench and rake the material to the correct level.
- Compact the premix thoroughly. The surface of the new edge should stand approximately 5 mm above the existing road surface after compaction.
- The surface of the patch must be dusted or sanded just before the final compaction pass in order to prevent "pick-up" by vehicles.
- After 3 days or more the patch must be sealed by applying bitumen emulsion and a single layer of 6 mm chippings. The chippings must be thoroughly rolled.

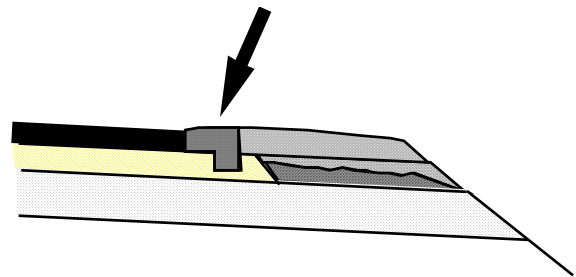

Work Method, Alternative 2:

- Dig and remove all unstable material until you reach firm material. Level the area.
- Brush out and clean the area.
- Rebuilt the base and sub-base using the same material. Compact thoroughly.
- Rebuilt the shoulder as described in method 1.
- Repair the surface edge as described in method 1.

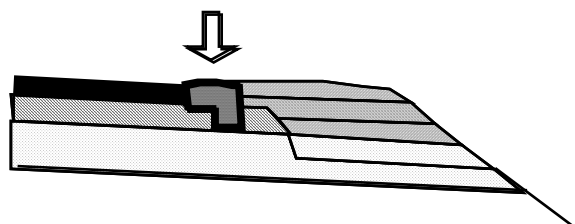
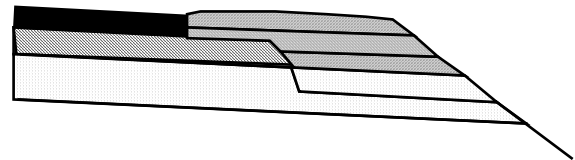
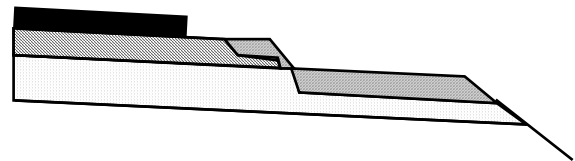
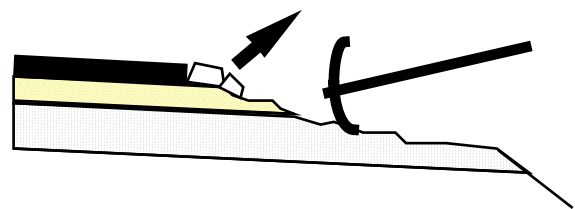

Tools and Equipment:

- Truck or pick-up with amber flashing light
- Pick Axes + Shovels
- Metal rakes with metal straight edge
- Wheelbarrow
- Hard Brooms and block brushes
- Small vibrator roller/plate or hand rammer
- Watering can with - rose head
- 2m straight edge
- Measuring tape

Material:

- Pegs
- Strings
- Marking Chalk
- Primer (60% Cationic or Anionic mix grade emulsion diluted to 50/50)
- Coldmix
- Solvent
- Sealant (as primer)

Safety Signs and Devices

- "Works ahead" Signs
- "Road narrows" Signs
- "slow down" Signs
- "Stop / Go" Boards
- Traffic Cones
- Red Flags
- Safety Vest

Suggested Productivity Range:

Repair carriageway edge: 10 – 20 m / day / labourer

Actual Productivity:

Activity Sheet **RM13****PATCH POTHOLES (including patching of local severe ruts/depressions)****Standard Specification:**

Road surface to be free from potholes.

Work Definition:

Fill potholes using approved material for sub-base, base and premix for surface layers.

Seasonal Priority:

Just before rains (1) / Rainy season (2) / Just after rains (3) / Dry season (4)

Work Method:

Mark the sides of the pothole in a rectangular shape. Check whether only the bitumen layer is affected or also the base or even sub-base layers.

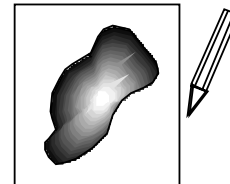

- Remove all loose material and excavate the pothole to at least 40mm depth until hard, firm ground is reached.
- Where the base, or even the sub-base, is affected, excavate loose material and refill with approved material. If necessary stabilise material as instructed by the Engineer. Compact with hand rammer in layers.
- The bottom of the pothole must be hard and brushed clean with a broom.
- Paint the bottom and sides of the pothole with prime (60% Cationic or Anionic mix grade emulsion diluted to 50/50) using a block brush. Paint evenly, not too much but that the prime covers the surface totally.
- Place coldmix in the pothole and rake out to 10mm above the existing road surface.
- Compact with hand rammer and / or roller / vibrator plate until a uniform level is reached.
- The surface of the asphalt must be even and with no holes.
- Paint the surface of the pothole with emulsion sealant (60% Cationic or Anionic mix grade emulsion diluted to 50/50). Sand if necessary.
- Keep traffic off the pothole until the surface is dry.

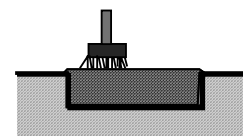
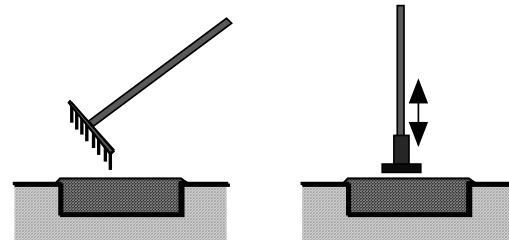
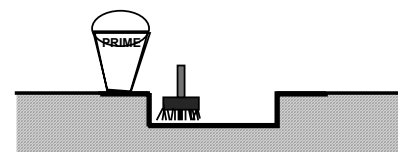
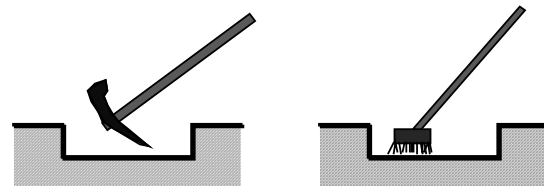
**Tools and Equipment:**

- Truck or pick-up with amber flashing light
- Pick Axes + Shovels
- Metal rakes with metal straight edge
- Wheelbarrow
- Hard Brooms and block brushes
- Small vibrator roller/plate or hand rammer
- Watering can with - rose head
- 2m straight edge and measuring tape

Material:

- Marking Chalk
- Primer (60% Cationic or Anionic mix grade emulsion diluted to 50/50)
- Coldmix
- Solvent
- Sealant (as primer)

Safety Signs and Devices

- "Works ahead" Signs
- "Road narrows" Signs
- "slow down" Signs
- "Stop / Go" Boards
- Traffic Cones
- Red Flags
- Safety Vest

Suggested Productivity Range:

Fill potholes: 4 – 10m² / day / labourer

Actual Productivity:

Activity Sheet **RM14** SEAL CRACKS

Standard Specification:

Surface to be free from cracks wider than 2mm

Work Definition:

Fill cracks with emulsion

Seasonal Priority:

Just before rains (1) / Rainy season (4) / Just after rains (2) / Dry season (3)

Work Method:

- Sweep the cracked area clean.
- Mark those cracks which are wider than 2mm with chalk.
- Pour emulsion in the cracks using a watering can. Use emulsion KRS60 or KMS60.
- Spread coarse sand over the filled cracks.
- If necessary repeat sanding at a later stage → check some days later whether the bitumen “bleeds” through the sand cover.

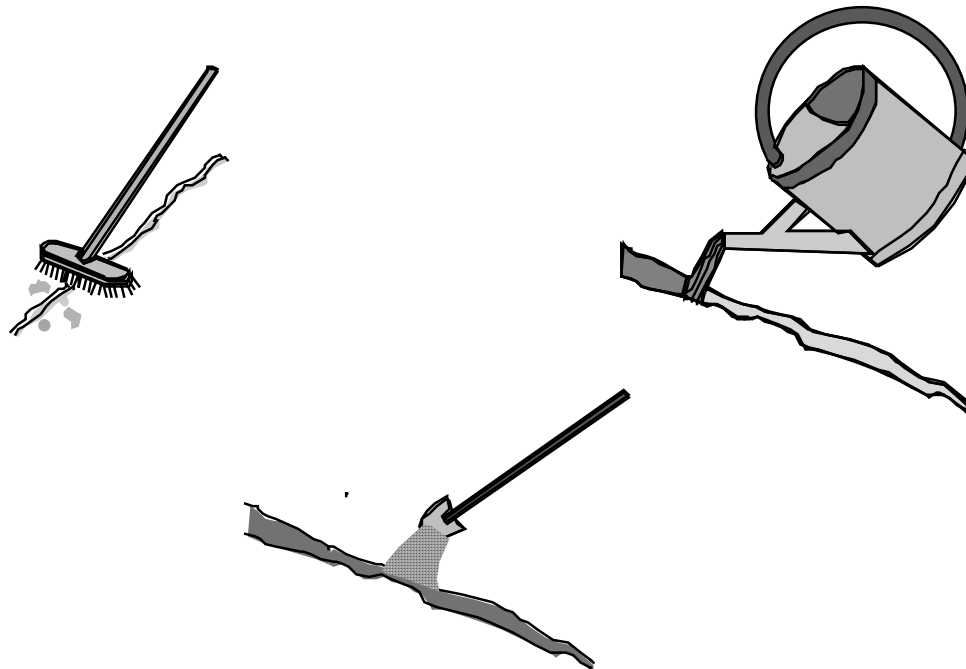

Special Considerations:

- Bitumen emulsion Cationic 60% is usually sold as KRS60. Also KMS60 may be used if KRS60 is not available.

Tools and Equipment:

- Truck or pick-up with amber flashing light
- Watering cans
- Shovels
- Wheelbarrow (for sand)
- Broom

Material:

- Chalk
- Bitumen emulsion, Cationic 60%
- Coarse sand

Safety Signs and Devices

- “Works ahead” Signs
- “Road narrows” Signs
- “slow down” Signs
- “Stop / Go” Boards
- Traffic Cones
- Red Flags
- Safety Vest

Suggested Productivity Range:

Fill cracks = day work

Actual Productivity:

Activity Sheet **RM15** *SLURRY SEAL FOR LOCALISED SEALING*

Standard Specification:

Carriageway to be free from cracks, depressions or large potholes.

Work Definition:

Apply slurry seal for patch repair.

Seasonal Priority:

Just before rains (1) / Rainy season (2) / Just after rains (3) / Dry season (4)

Work Method:

- Mark the sides of the area to be rectified in a rectangular shape.
- Sweep the area clean with a hard broom.
- If oil spillage on the road surface, wash off with paraffin or diesel oil and brooms
- Lay a rope or battens around area to be rectified - of the required diameter/thickness.
- Make certain no free water is present when the application of slurry begins, but the surface could be lightly dampened
- Hand-mix the slurry on the road or in a wheelbarrow. Alternatively a small concrete mixer can be used
- The crusher dust is first mixed thoroughly with cement.
- The bitumen emulsion is added, and the mixing process is continued. If the mix appears too dry, small quantities of water should be added. When a creamy workable consistency is obtained, mixing must be stopped
- The slurry is now poured onto the prepared area.
- With the use of squeegees it is evenly spread over the area to a thickness of 5mm. Finish off the surface by either brushing lightly with a broom or by dragging a piece of wet hessian.

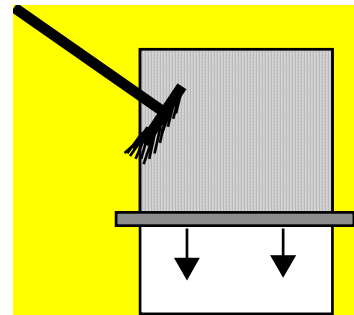
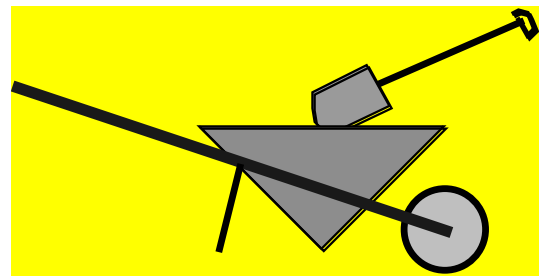
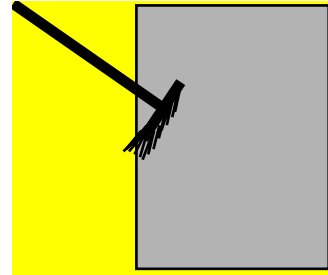

Tools and Equipment:

- Truck or pick-up with flashing light
- Shovels
- Squeegees
- 20l bucket
- Optional: Concrete mixer
- Wheelbarrows
- Hard Brooms and block brushes
- Vibrator roller/plate or hand rammer
- Watering can with - rose head
- 2m straight edge and measuring tape

Material:

- Crusher dust, 0 – 3mm refer envelope on next page
- Portland cement, 1.5 to 3Kg (approx. 1 to 2%) by weight
- Anionic emulsion, 60% stable-mix grade emulsion – 23% by volume

Safety Signs and Devices

- "Works ahead" Signs
- "Road narrows" Signs
- "slow down" Signs
- "Stop / Go" Boards
- Traffic Cones
- Red Flags
- Safety Vest

Suggested Productivity Range:

Apply slurry seal = 5 to 20 m² / day / labourer

Actual Productivity:

MODULE L:
MAINTENANCE OF PLANT AND VEHICLES

L.1	Introduction	L-1
L.2	Workshop Set-up	L-1
L.3	Control System	L-3
L.4	Maintenance of Plant	L-5

L.1 INTRODUCTION

The importance of proper, regular plant and vehicle maintenance cannot be overemphasised. Everything you do as a contractor should either make you money or save you money. Plant and vehicle maintenance costs money immediately, but saves you much more in the long run. Regular maintenance is carried out in order to:

- prevent damage to the plant/vehicle and auxiliary equipment by locating worn out or wrongly adjusted parts,
- have a fully available and efficient plant/vehicle fleet, and
- prevent accidents.

Daily and weekly maintenance must be carried out (see recommended maintenance checklists under Sections L.4 and L.5). For this purpose it is important that operators and drivers are provided with enough time to check their machines and vehicles. For daily maintenance at least 1/2 hour should be set aside. Monthly or kilometre/hour based services have to be carried out in accordance with the manufacturers instructions (consult service manuals).

L.2 WORKSHOP SET-UP

A simple workshop with essential equipment and tools needs to be set up at the main camp, or for larger contracts on site, where repair work and major services can be carried out. The minimum requirements for a workshop are:

- a roof covered area of about 50 to 60 m²
- one inspection pit (or ramp)
- cemented workshop floor
- a small store for spare parts, tools & equipment

The level of the workshop floor should be kept above the surrounding ground which must be well drained. If possible, electricity and water should be provided. The store must have lockable doors. To provide sufficient light in the workshop some transparent roofing sheets can be installed. Such a workshop would be sufficient to maintain all equipment and vehicles that are required for labour-based road construction or rehabilitation contracts. The following arrangements are recommended for the main workshop and the site:

Suggested work to be carried out in the main <u>workshop</u>:	Suggested work to be carried out at <u>site</u>:
<ul style="list-style-type: none"> • monthly services • suspension repairs • steering system repairs • electrical system repairs • fuel system repair, except fuel pumps • brake system repairs • removal and replacement of exchange units • engine tuning • tyres and tubes repairs and exchange • other minor repairs <p>(One qualified mechanic and one or two mechanical assistants are required for this work).</p>	<ul style="list-style-type: none"> • regular services if distance to main camp is too far • daily inspection, cleaning and greasing • tyre and tube repairs • wheel bearing adjustment • battery checking and filling • tightening and replacement of bolts and nuts <p>(Daily inspection, greasing and cleaning should be carried out by the drivers and mechanics. On a larger site it will pay off to have a reliable mechanical assistant employed.)</p>

Recommended <u>workshop</u> equipment and tools:	Recommended <u>site</u> equipment and tools:
<ul style="list-style-type: none"> • Portable arc welding equipment with a 220 V AC power outlet. For the welder an apron, gloves, safety goggles, etc. • Gas welding and cutting outfit • Anvil - Forge if tools from the field, like shoves, picks etc. are to be repaired at the District Workshop. • Air compressor (not absolutely necessary) or foot pump • Angle grinder • Hard wood work bench • Hand drilling machine with 16 mm check and different speeds • Torque wrench 50 - 225 NM • Circlip pliers external 25 - 90 mm diameter • Circlip pliers internal 25 - 90 mm diameter • Drill set 2-26 mm diameter • Set of taps, according to the fleet metric/imperial/UNF/BSF • Pop rivet set • Set of bearing pullers • Multimeter = Volts/Amps/Ohm for DC up to 36/6000/10,000 • Battery service and testing kit • Battery charger • Soldering iron • Common mechanical tools and tool boxes 	<ul style="list-style-type: none"> • Complete spare tyres for all equipment on site • Common mechanical tool box • Tyre levers • Electric pressure pump, to be driven by tractor battery • Axle stands • Hydraulic jack 5 tons • Strong ropes • Winch (hand operated) and steel ropes

Recommended spare parts to be kept at <u>workshop</u> :	ed spare parts to be kept at <u>site</u> :
<p><i>Fast Moving Items (to be ready at all times)</i></p> <ul style="list-style-type: none"> • Oil filter • Fuel filter • Spark plug • Points • Engine mountings • Bulbs for head lamps, side lamps, stop lights, indicators • Terminal and cabin mountings • Fan belts • Fuses • V-belts • Spring bushes • Wiper blades • Ball joints • Gasket for rocker arm cover • Radiator hose lower/upper • Air cleaner element • Speedometer cable • Shock absorber • Tyres and tubes 	<ul style="list-style-type: none"> • Oil and Grease • Brake fluid • Assorted nuts & bolts & washers • Patches + solution gum • Cleaning material • Insulation tape • Electrical connections • Electrical wire

<p>Slow Moving Items (to have few on stock)</p> <ul style="list-style-type: none"> • Coils • Injection nozzles • Brake linings/pads • Main leaf • U-bolt • Centre bolt • Water pump repair kit • Brush for starter • Brush for alternator <p>Consumption Items (to have sufficient in stock)</p> <ul style="list-style-type: none"> • Oils • Grease • Brake fluid • Assorted nuts & bolts & washers • Patches + solution gum • Cleaning material • Welding rods/gas + electric • Gas • Soldering fluid/powder • Insulation tape • Electrical connections • Electrical wire 	
---	--

L.3 CONTROL SYSTEM

Equipment and vehicles are usually the most expensive investments for a contractor. A proper control system must therefore be in place. This does not require a sophisticated system, but it should provide sufficient information on the use of the equipment and the mechanical work carried out including the use of spare parts and consumables. For each piece of equipment or vehicle the following needs to be known:

1. availability and utilisation rates,
2. fuel consumption,
3. spare-part consumption,
4. its present condition,
5. operating costs over a certain time.

The easiest system for a contractor is to have a separate logbook for each piece of equipment and vehicle. This can be a simple note book which you can prepare yourself. The following details should be recorded on a daily basis:

1. date,
2. working site or journey details,
3. odometer/hour-meter at the beginning and end of each day, plus distance/time driven,
4. fuel and oil issued (= fuel consumption per km or hour),
5. signature of driver

Example of Logbook (operations)

Date	Details of Journey	Km/Hr before	Km/Hr after	Total Km/Hr this Journey	Fuel Issued	Signature Driver

On a separate page of the log book service and repair details can be recorded. You can also specify in the log book when the routine services are planned, so that the driver/operator, site supervisor and the mechanic can always check when the next service is due.

The daily movements of the equipment or vehicle should always be signed by the driver, while the repairs and services should be specified and signed by the mechanic.

Example of a Logbook (maintenance record)

Date	Details of Repair / Service	Spare Parts used	Consumable Items used	Signature Mechanic	Next Service



It is important that you analyse the entries in the log books at least once a month. Take your time to do this, you might loose a lot of money if you don't!!

To keep all equipment in good condition it is important to have it inspected and serviced regularly. You therefore have to plan the services accordingly and to make sure the necessary arrangements are made in time. It is recommended to prepare a yearly service schedule for all vehicles and equipment.

Maintenance service schedules are based on kilometres driven or engine hours operated. In addition, daily and weekly checks have to be carried out. However, it is recommended to plan the service schedule on a regular time schedule, e.g. every two months, regardless whether each piece of equipment has reached the targeted hours or kilometres (of course, you must not let the equipment pass the kilometres- or hourly-based service limit as set by the manufacturer). This system allows a better planning of operations and gives your machinery a regular service in good time, whether the milometer or hour-meter is working or not. The other advantage is also that your staff will get used to regular services and it will become routine for them. Ask your equipment and vehicle dealers for advice on the detailed requirements for services.

L.4 MAINTENANCE OF PLANT



These checklist only recommend daily and weekly routine service procedures. Monthly or mileage/hourly based services must be carried according to the instructions of the manufacturer. Consult the service manual or the manufacturer’s representative.

Checklist for DAILY SERVICE of <u>Plants</u>	
Service Item	Remarks
A.) “walk around check”: 1. oil, fuel or water leak 2. loose or missing nuts 3. worn-out tyres 4. blade/bucket wear or damage 5. bolts and safety-pins on tractor hydraulic operated auto-hitch and other hitches 6. operators compartment 7. cleanliness	
B.) engine transmission check. 1. engine oil level 2. transmission oil level 3. hydraulic system oil level 4. engine coolant level 5. fuel level 6. fan belt adjustment 7. battery electrolyte level 8. battery terminals 9. free movement of controls	- top up if necessary - use correct oil type! - - top up if necessary with clean water - fuel tank must be filled after each shift or at end of day - - top up if necessary with distilled water - clean if dirty
C.) cleaning 1. pre-cleaners 2. air filter 3. tyres / tracks	
D.) greasing 1. nipples 2. all units	- consult service manual to know which nipples to grease daily - only if the plant has worked in water

Checklist for WEEKLY SERVICE of <u>Plants</u>	
Service Item	Remarks
A.) washing the plant	
B.) checking oil levels: 1. engine 2. gearbox 3. transmission 4. differential 5. final drive 6. torque converter 7. all gear cases and reduction gear cases	general: top up if necessary, use correct oil type and do not overfill
C.) greasing <u>all</u> nipples	
D.) tracks: 1. cleaning 2. inspecting for loose and missing parts and leaks 3. lubrication rollers, idlers and sprockets	
D.) wheels and tyres: 1. cleaning 2. checking and tightening nuts 3. controlling free play 4. checking tyre inflation	- tyres must be cold for inflation check
D.) cooling system and fanbelt: 1. checking radiator and hoses for damage, leaks and clogging 2. topping up engine coolant level 3. checking belt tension	- clean if necessary - use only clean water - adjust if necessary
E.) mould board, blade, bucket: 1. tightening pins and bolts 2. checking cutting edges and bits	- replace if required - for dozers and graders, including towed graders
F.) air filters: 1. cleaning pre-cleaners 2. cleaning primary filters	- do not operate plants with air-cleaners disconnected!
G.) electrical system: 1. topping up battery electrolyte levels 2. cleaning top of battery and terminals 3. inspecting cables	- use only distilled water
H.) fuel system: 1. drainage of any sediment from diesel tank 2. cleaning strainer in fuel tank filler opening 3. cleaning fuel tank breather 4. cleaning primary filters 5. draining secondary filters	- only if valve fitted
I.) hydraulic system: 1. checking pipes connections and seals for leaks 2. checking and tightening cap screws	

Checklist for DAILY SERVICE of <u>Vehicles</u>	
Service Item	Remarks
A.) checks inside passenger's compartment 1. cleanliness 2. fuel 3. parking brakes, horn, wipers 4. tools (spare wheel, spanner, jack and handle)	- always fill tank after work is completed
B.) checks after starting the engine 1. speedometer and gauges 2. warning and indicator lamps 3. lights and indicators 4. foot brake 5. abnormal noises	
C.) engine checks 1. oil leaks 2. coolant level and radiator leaks 3. battery terminals 4. oil level 5. level of windscreen cleaning water	- call mechanic if oil leaks - top up if necessary - tighten or clean if necessary - top up if necessary - to up if necessary

Checklist for WEEKLY SERVICE of <u>Vehicles</u>	
Service Item	Remarks
A.) washing the vehicle	
B.) visual checks: 1. body work for dents and cracks 2. body bolts and nuts 3. chassis frame and cross members 4. road springs and U bolts 5. oil, fuel or water leaks 6. all lights, indicators, gauges, etc.	
C.) checking oil levels: 1. engine oil level 2. brake fluid level 3. hydraulics oil level 4. gearbox oil level 5. differential oil level	general: top up if necessary
D.) greasing all points:	- consult manufacturer's manual for greasing points
E.) wheels and tyres: 1. checking and tightening all nuts 2. checking free play 3. tyre pressure	- also check spare wheel
F.) cooling system and fanbelt: 1. checking of cooling level 2. belt tension	- top-up with clean water if necessary - adjust if necessary

<p>G.) air filter: 1. cleaning 2. changing air cleaner oil</p>	
<p>H.) electrical system: 1. checking electrolyte level 2. cleaning battery and terminal 3. inspecting all cables</p>	<p>- top up with distilled water if necessary</p>
<p>I.) miscellaneous: 1. cleaning breathers 2. draining servo unit 3. draining fuel tank 4. checking clutch and brake pedal free play</p>	

Safety hints during maintenance service:

- Do not service the plant or vehicle while the engine is operating.
- Do not allow unauthorised personnel on the plant or vehicle when it is being repaired.
- Lower all cable or hydraulic controlled equipment before servicing. When work is to be done with the blade suspended, put a block under it.
- When inflating a tyre be careful to prevent the air pressure from rising too high. During inflation, keep your body away from the tyre.
- Stop the engine when checking or adjusting fanbelt and rotary parts.
- Do not leave metal objects on the battery. Short-circuiting of the electrodes will generate sparks which damage the battery and can create fire danger. Always disconnect the battery before repairing the electrical system
- When you use gasoline for cleaning purposes, make sure that there is no naked flame in the vicinity.
- Wait until the cooling water temperature drops, then remove the radiator cap carefully. Loosen it little by little to let the pressure escape.



WARNING!

Before starting maintenance work:

- **ENSURE** that the person doing the work is:
 - a.) **competent to do it**
 - b.) **fully conversant with the machine or vehicle**
 - c.) **ensure that all safety precautions have been met**
- **ensure that the machine is at a standstill and completely switched off**
- **ensure that the machine is on level ground**
- **ensure that the machine is secured against all movement**

On completion of work:

- **ensure that all safety devices have been correctly refitted, adjusted and tested!**
- **ensure that all aspects of the machine are functioning correctly!**

MODULE M:

PRODUCTIVITY GUIDELINES

M.1	General	M-1
M.2	Productivity Rates for Earth Road Works	M-1
M.3	Productivity Rates for Graveling Works	M-3
M.4	Productivity Rates for Hauling Equipment	M-5
M.5	Productivity Rates for Routine Maintenance Works	M-6

M.1 INTRODUCTION

Productivity rates are most essential for planning of and costing of works. Without reliable productivity rates at hand neither the client nor the contractor will be able to prepare realistic plans and estimates. Winning or losing a tender is very often a question of what rates have been assumed for the Bill of Quantity (BQ) items.

Often the client maintains a schedule of rates (also called norms) for all possible work items. Also well-developed contractor associations provide their members with regularly updated schedules as guidelines for planning and tendering of jobs. However, whether or not such services are available, each individual contractor must maintain his own record of rates that is based on his own site experience.

This Module provides guidelines for productivity rates for most of the activities that are carried out on labour-based sites.



Use these productivity guidelines cautiously. Develop your own set of rates based on your site experience.

Due to the fact that the task rate system is being used as the most practicable and effective system for work planning, allocation and supervision on most labour-based sites, this Module will present productivity rates also on the basis of task rates. For estimating/costing purposes the rates will have to be converted into unit coefficients. In other words, the time that is required to carry out one unit of a certain BQ item.

Example:

- The assumed task rate for excavation of normal soil is 4m³ per worker-day.
- The respective productivity coefficient for 1m³ is 0.25 of a worker-day (1 day divided by 4m³).



For information on the different incentive schemes and how to establish task rates, please refer to Module Section E.4.2, Site Work Planning.

M.2 PRODUCTIVITY RATES FOR EARTH ROAD WORKS

The following table provides a possible range of task rates for the common earth road construction activities. These rates will need to be reduced for activities in confined spaces or where there are obstructions, e.g. excavating tree roots or beside foundations of structures.

TABLE F.6 - TASK RATES		LINEAR PRODUCTIVITY IN METRES PER MANDAY							REMARKS
		CROSS SECTION TYPE							
ACTIVITY	TASK RATE	A1	A2	B	C	D	E		
Bush clearing	300 - 800 m ² /md	60 - 160 m	67 - 178 m	75 - 200 m	86 - 229 m	55 - 145 m	55 - 145 m	md = manday; Volumes measured insitu.	
Stripping & grubbing	100 - 200 m ² /md	20 - 40 m	22 - 44 m	25 - 50 m	29 - 57 m	18 - 36 m	18 - 36 m	Quantity measured on area covered by vegetation only.	
Tree & stump removal	150 - 250 m ² /md	30 - 50 m	33 - 56 m	38 - 63 m	43 - 71 m	27 - 45 m	27 - 45 m	Small stumps task rate per m ² . Big ones by No.	
Boulder removal	300 - 800 m ³ /md								
Slotting	3 - 4 slots/md	30 - 40 m	33 - 44 m	43 - 57 m	50 - 67 m	25 - 33 m	25 - 33 m	Task rate to be increased in flat terrain.	
Excavation to level	3.0 - 4.0 m ³ /md	2 - 3 m	3 - 4 m	3 - 5 m	4 - 5 m	2 - 3 m	0.4 - 1 m		
Ditching	2.0 - 3.5 m ³ /md	3 - 6 m	5 - 9 m	8 - 14 m	8 - 14 m	2 - 4 m	N/A	Ditching, backslapping and sloping to be given as combined activities together with spreading; Linear Productivity includes drain on both sides of the road.	
Spreading	10 - 20 m ³ /md								
Backslapping	2.5 - 4.0 m ³ /md	17 - 27 m	20 - 32 m	20 - 32 m	33 - 53 m	8 - 13 m	N/A		
Sloping	2.5 - 4.0 m ³ /md	7 - 11 m	10 - 16 m	10 - 16 m	13 - 20 m	6 - 9 m	N/A		
Camber formation	100 - 200 m ² /md	18 - 36 m	20 - 40 m	25 - 50 m	29 - 57 m	17 - 33 m	14 - 29 m		
Mitre drains	3.0 - 4.0 m ³ /md								
Scour checks	1.0 - 2.0 No./md							Including collection of stones and pegs.	
Culvert laying	1.0 - 2.0 m/md							Group task	
Catch water drains	3.0 - 4.0 m ³ /md								
Hauling	4.5 - 9.0 m ³ /md								
Masonry work	0.3 - 0.5 m ³ /md								

TASK RATES FOR HAULING BY WHEELBARROW		
Hauling Distance	Task Rate Measured On Site (Equivalent Insitu Material)	No. Of Trips
0 - 40m	10.5m ³ /WD	210
40 - 60m	8.0m ³ / WD	160
60 - 80m	6.5m ³ / WD	130
80 - 100m	5.5m ³ / WD	110
100 - 150m	4.5m ³ / WD	90

Notes:

- The volume of a typical wheelbarrow is equivalent to 0.05m³ of compacted material (20 loads per m³).
- Task rate for hauling and tipping only; excludes loading and spreading.
- Assuming wheelbarrow volume equivalent to 0.05m³ of compacted/insitu material (0.07m³ loose) when struck level with top of bodywork.
- 2 wheelbarrows assigned to each hauling labourer.
- Good haul route (reduce tasks for poor haul route).

M.3 PRODUCTIVITY RATES FOR GRAVELLING WORKS



Gang tasks should be used for gravelling operations wherever possible.

TASK RATES FOR PREPARATION ACTIVITIES	
Activity	Task Rate
Reshaping road	20 - 50 m/WD
Clearing bush	200 - 1000 m ² /WD
Excavating overburden + loading onto wheelbarrow if necessary	2 - 4 m ³ /WD
Hauling by wheelbarrow	See table above

TASK RATES FOR GRAVELLING ACTIVITIES	
Activity	Task Rate/ Person
Excavating Gravel	1.6 - 2.4 m ³ /WD (insitu) 2 - 3 m ³ /WD (loose)
Loading Gravel onto Trailer	8 - 10 m ³ /WD (loose)
Loading Gravel onto Trucks	5 - 7.5 m ³ /WD (loose)
Off Loading and Spreading	12 - 16 m ³ /WD (loose)

The labourers assigned to each activity can be determined using the total quantities to be hauled and the productivity ranges shown in the table above.

The graph on the following page gives the daily labour requirements for various quantities of gravel to be hauled based on "balanced" gang sizes.

FIGURE J.8 – LABOUR REQUIREMENT FOR GRAVELLING ACTIVITIES

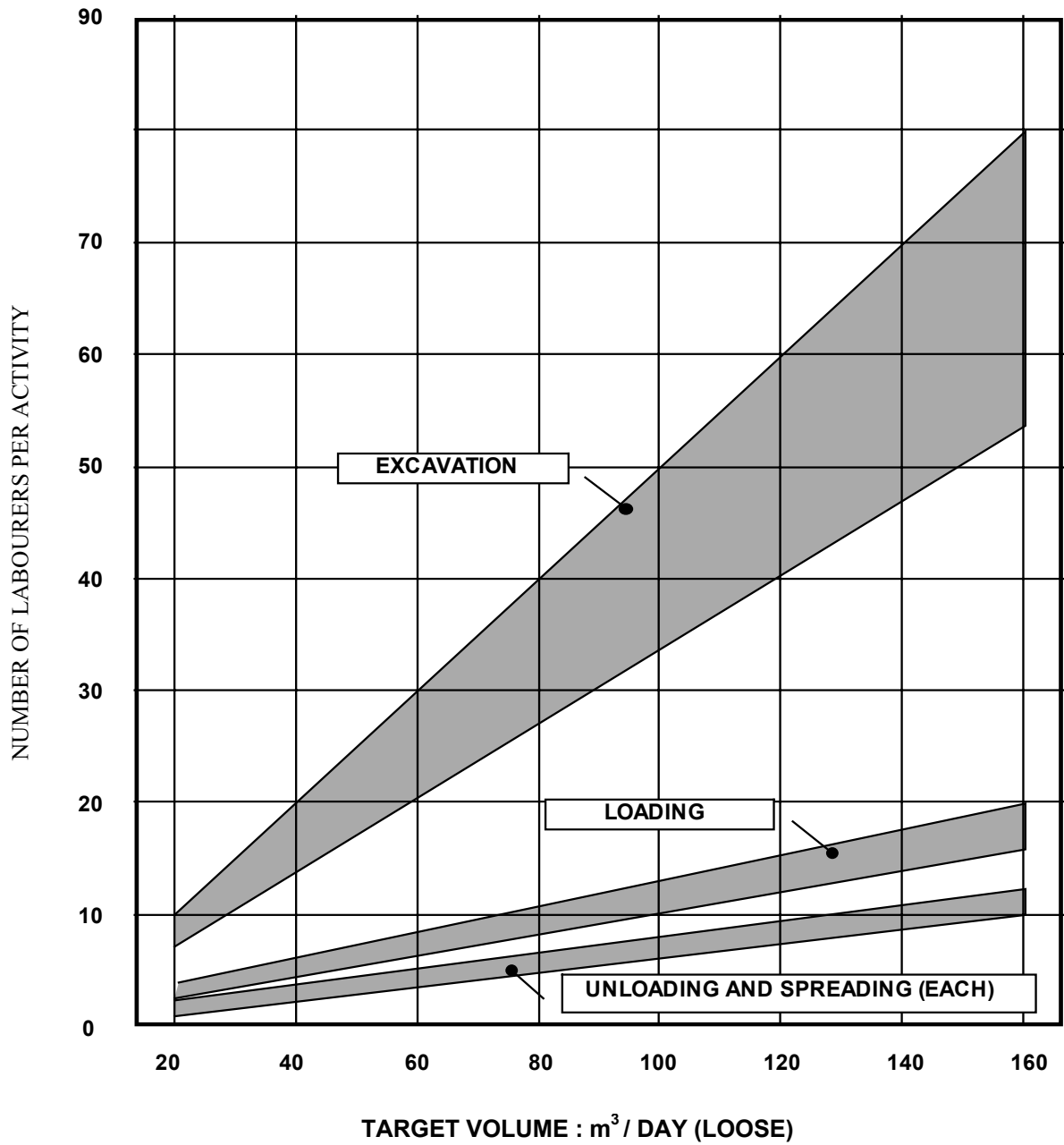

Each band shows the number of labourers required for each activity according to the amount of (loose) gravel to be hauled during the day. The bands are based on the productivity ranges in Table J.5. Minimum loading gang size should be 4 (tractors and trailers) and 8 (for trucks).

M.4 PRODUCTIVITY RATES FOR HAULING EQUIPMENT**Principle:**

The haul distance, type of equipment used and condition of the haul route determine the quantity of gravel that can be hauled in a day by each operational piece of haulage equipment. An estimation of expected haulage productivity is best achieved by analysing separately the time requirements for each of the sub-activities involved as follows:

- Loading of gravel in quarry
- Haulage of full tractor/trailer or truck from quarry to dumping site
- Off-loading of gravel at dumping site
- Return of empty tractor/trailer or truck from dumping site to quarry

Choice of Haulage Equipment:

- The maximum economic hauling distance of gravel by the tractor/trailer combination is usually about 2 - 4 km.
- Trucks may be economic for any distance up to about 20 km.
- The number of pieces of haulage equipment to be used is determined after establishing the quantity of stockpiled gravel that is ready for hauling, the haul distance, and the number of labourers available.

Gravelling Cycle Times:

Haul Distance	CYCLE TIME IN MINUTES							
	Tractor / Trailer				7 Ton Truck			
	45 – 55 HP		56 – 75 HP		Flat Bed		Tipper	
	Poor	Good	Poor	Good	Poor	Good	Poor	Good
0 – 1	26	22	24	21	44	42	38	36
1 – 2	41	29	36	28	51	45	45	39
2 – 3	56	37	47	34	57	47	51	41
3 – 4	71	45	59	40	63	50	57	44
4 – 5	87	52	71	47	70	52	64	46
5 – 6	102	60	82	53	76	55	70	49
6 – 7	117	68	94	59	83	57	77	51
7 – 8	132	75	106	66	89	60	83	54
8 – 10	156	87	123	75	99	64	93	58
10 – 12	186	102	146	88	111	69	105	63
12 – 14	216	117	170	100	124	74	118	68
14 – 16	247	132	193	113	137	79	131	73
16 – 20	292	155	228	132	156	86	150	80
20 – 24	353	186	275	157	182	96	176	90
24 – 30	429	224	333	189	214	109	208	103
Assumptions	LOADING AND OFF-LOADING IN MINUTES							
	Tractor / Trailer				7 Ton Truck			
	45 – 55 HP		56 – 75 HP		Flat Bed		Tipper	
	Loading	6		6		25		30
Off-loading	12		12		16		5	
	TRAVEL SPEED IN KM/HOUR							
	Tractor / Trailer				7 Ton Truck			
	45 – 55 HP		56 – 75 HP		Flat Bed		Tipper	
	Poor	Good	Poor	Good	Poor	Good	Poor	Good
Full	7	14	9	18	15	40	15	40
Empty	9	18	12	20	25	60	25	60

Haul Distance	GRAVELLING DAILY LOAD TARGETS: GOOD & POOR HAUL ROUTES							
	Tractor / Trailer				7 Ton Truck			
	45 – 55 HP		56 – 75 HP		Flat Bed		Tipper	
	Poor	Good	Poor	Good	Poor	Good	Poor	Good
0 – 1	16	19	18	20	10	10	11	12
1 – 2	10	14	12	15	8	9	9	11
2 – 3	7	11	9	12	7	9	8	10
3 – 4	6	9	7	10	7	8	7	10
4 – 5	5	8	6	9	6	8	7	9
5 – 6	4	7	5	8	6	8	6	9
6 – 7	4	6	4	7	5	7	5	8
7 – 8	3	6	4	6	5	7	5	8
8 – 10	3	5	3	6	4	7	5	7
10 – 12	2	4	3	5	4	6	4	7
12 – 14	2	4	2	4	3	6	4	6
14 – 16	2	3	2	4	3	5	3	6
16 – 20	1	3	2	3	3	5	3	5
20 – 24	1	2	2	3	2	4	2	5
24 – 30	1	2	1	2	2	4	2	4

Assumptions: Daily working hours for tractors/trailers and trucks = total working hours (8) minus service hour (1) = actual time on hauling job = **7 hours per day**

M.5 PRODUCTIVITY RATES FOR ROUTINE MAINTENANCE WORKS

Setting task rates for routine maintenance is not a straightforward issue as the conditions can vary significantly. The table below provides an overview of possible range of rates. Detailed site investigations are required for establishing accurate task rates in a given case.

TASK RATES FOR ROUTINE MAINTENANCE ACTIVITIES	
Activity	Task Rate Range (Per day / labourer)
RM1: Inspect and remove obstructions	8000 – 10,000 m
RM2A: Clean culverts	1 to 2 culvert lines
RM2B: Repair erosion in culvert inlets, outlets and discharge drains	2 to 3 m ³
RM3: Clean mitre drains	2 to 3 m ³
RM4A: Clean side drains	2 to 3 m ³
RM4B: Repair side drain erosion	Varying, depending on condition
RM5: Repair sour checks	2 – 4 No.
RM6: Repair shoulder, side slope and back slope erosion	5 to 10 m ²
RM7: Repair Potholes	5 to 10 m ²
RM8: Reshape carriageway and repair ruts and gullies	5 to 10 m ²
RM9: Repair culverts	Day Work
RM10: Control vegetation	100 to 300 m ²
RM11: Grub edges of carriageway and shoulder	100 to 300 m

Activity	Task Rate Range (Per day / labourer)
Preparation: Prepare cold asphalt premix, hand mixing	3 to 4 m ³
RM12: Patch surface edge	10 to 20 m
RM13: Patch potholes (including local severe ruts/depressions)	4 to 10 m ²
RM14: Seal Cracks	Day Work
RM15: Slurry seal for localised sealing	? to ? m ²

MODULE N:
WORKS PROGRAMMING AND REPORTING

N.1	Introduction	N-1
N.2	Required Plans and Reports	N-2
N.3	Planning Process	N-3
N.4	Useful Planning Checklists	N-4

N.1 INTRODUCTION

Road construction, rehabilitation or maintenance contracts are complex management tasks. They involve a lot of money and other resources and are therefore a potential risk to the contractor and the client. Conditions are changing almost on a daily basis and the effective co-ordination of human beings and equipment is particularly challenging. Adequate planning is the first step to a successful project. Reporting is essential to monitor the site activities and to control costs.

In order cope with these demands a structured management process is required. The management tasks can be subdivided based on the project phases. The management process is a constant cycle of planning, decision making, monitoring, correcting and re-planning activities:

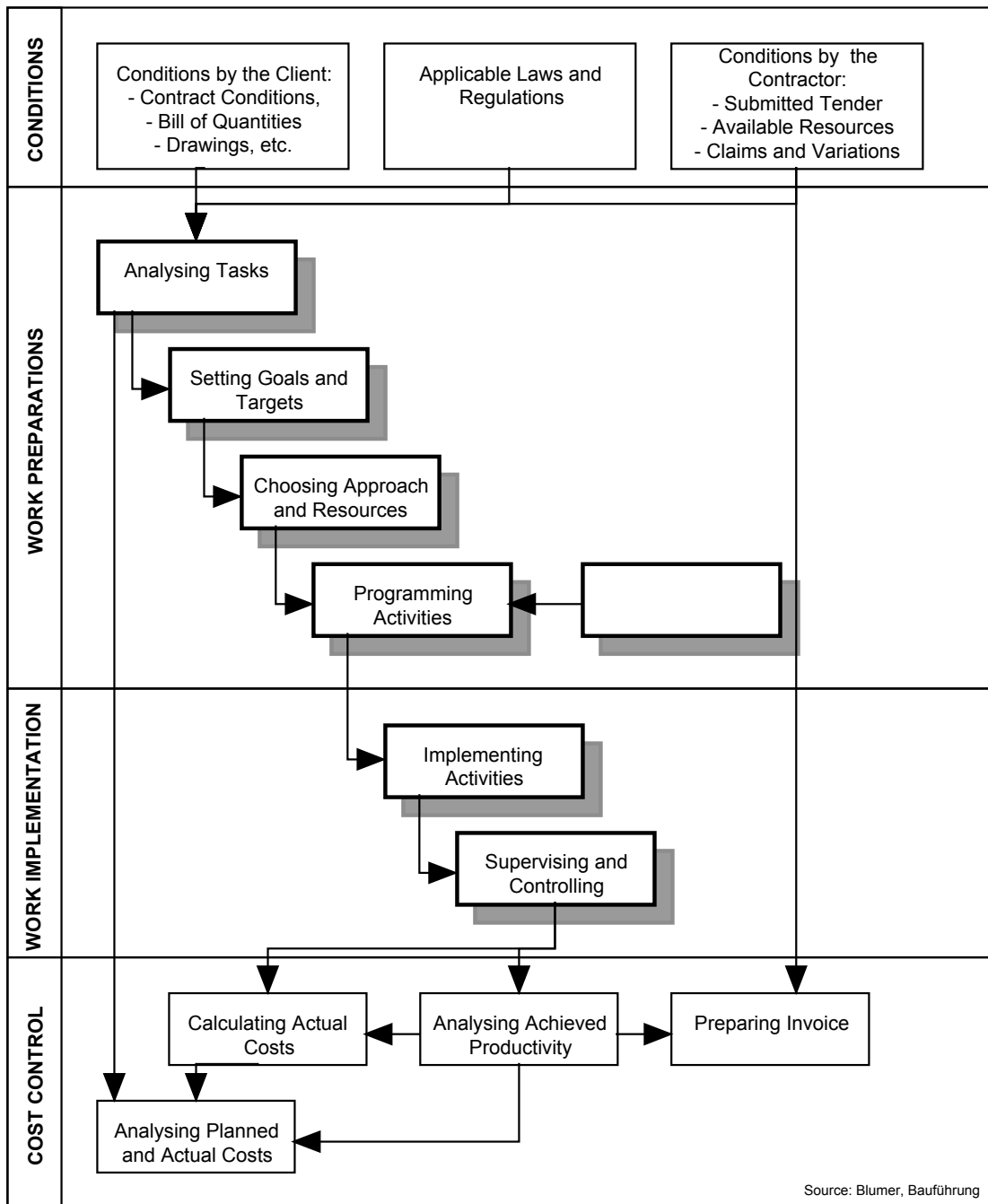

It is not within the scope of this module to provide detailed planning and reporting systems for road work operations, but it will suggest general and practical planning and reporting guidelines for labour-based road work contracts.

N.2 REQUIRED PLANS AND REPORTS

For labour-based road work projects the following minimal set of plans and reports is recommended:

Plan / Report	Purpose / Remarks
Site Inspection Report	Overall assessment of the site conditions prior to the commencement of works. This is usually carried out as part of the tendering process. (See notes under N.3 and N.4).
Project Work Programme (Plan)	This is the overall work programme for the entire project. The work programme is usually already required as part of the tender, but must be reviewed and detailed further before the work commences. The programme includes all required inputs, activities and activity targets. (See notes N.3)
Labour Record (Musterroll)	Records the recruited labour and the actual labour attendance. This is the base for labour payments.
Earth Works Calculations	This plan is used to exactly calculate the volume of earth works required for road construction (and sometimes rehabilitation). This plan is important to estimate the weekly and daily labour (and equipment) requirements.
Weekly Site Plans / Reports	Weekly Site Plans are required to plan the activities, estimate the targets (productivity) to be achieved and the resources in terms of labour, equipment and material to be used. The report, usually the same form is used, records the actual performance achieved. This feedback is very important to monitor the Project Work Programme and actual costs achieved.
Daily Site Plans / Reports	Daily Site Plans are necessary to plan all site activities in detail for each of the major operations. Major operations can be: <ul style="list-style-type: none"> • earth road construction (or rehabilitation) • gravelling (or regravelling), • culvert production, • structure work. These forms are particularly important for the allocation of tasks to the labourers and to ensure that labour and equipment are efficiently utilised. The report on the same form allows to control and monitor the progress of work and the resources used. This can then be used to re-calculate productivity rates and compare it with the assumptions made when estimating the item prices for the tender.
Store Records	Store records are essential to record all material and tools received and issued at site. The system has to allow for recording the tools issued to individual labourers and the material spent for each work site, e.g. structure sites. Other consumables, like petrol, diesel, oil, etc. must also be recorded. These records are important to control costs and to avoid misuse.
Equipment Records	Besides the equipment logbooks (see Module L.) where the movements and consumption of fuel plus the service details are recorded, no other records are necessary to keep track of the equipment usage details. However, the equipment operations on site must be planned together with the manual activities (see work programme, daily and weekly plans above).
Maintenance Plans and Reports	For maintenance, special plans and reports have to be prepared based on the adopted maintenance management system and the arrangements chosen for carrying out maintenance work.

N.3 PLANNING PROCESS

Planning a road construction project means:

1. deciding when the operations should start and when they should end,
2. calculating the labour requirements,
3. calculating the materials requirements,
4. calculating the equipment and tools requirements,
5. scheduling (programming) the ordering of materials, recruitment of labour, transportation, use of equipment and execution of construction activities,
6. calculating the cash requirements.

Preparations for planning:

In order to be able to prepare a plan one needs to have available essential data and background information, like:

- site inspection report
- contract document with specifications and work drawings
- list of available personnel, especially skilled labour
- list of available equipment
- list of available tools
- list of material required

Producing a Project Work Programme:

Armed with this information an overall Project Work Programme or Plan can be drawn up. This is usually done using the bar chart method. The following method is recommended:

- a) List all the activities you can think of, step by step, from the very beginning to the last activity. Split complex activities into smaller, manageable work units.
- b) Group the activities into a logic and chronological order, the way they will follow each other when carrying out the job.
- c) Identify from the bill of quantities the quantity for each respective activity.
- d) Estimate the number of workers you require to carry out the above activities considering the likely productivity rates and the operational arrangements.
- e) Estimate the equipment input you require to assist in carrying out the above activities.
- f) From there, calculate the time required for each activity and draw it onto the bar chart.
- g) Now re-check your bar chart and identify the bottlenecks. Some activities are probably taking too long, others might overlap unnecessarily with other activities creating a problem with your resources, etc. Refine the bar chart until you feel it reflects a practical and achievable approach.

Remember:

- The bar chart is a picture of how the work is going to be carried out.
- The bar chart shows how the various operations fit together.
- Always review and update the chart when the job is awarded and in progress.
- Make sure your site supervisory staff understand the plan.
- Display the bar chart in the site office.
- Make sure you monitor the performance on the different activities against the plan.
- Discuss the bar chart targets and the actual work achieved with your site supervisors every week.

From this overall work plan the weekly and daily plans can then be established. Typical forms used on I.b. sites in Zambia are shown in the Annex to this Module. Also shown in the Annex are simple musterrolls and store forms.



Although it is absolutely essential to use planning and reporting forms, make sure to use only the very necessary forms which provide you with the information to plan and control your work effectively.

N.4 USEFUL PLANNING CHECKLISTS

Checklist for Site Inspections:

Before you start preparing a tender and work plans you must visit the site and carry out a thorough site inspection. Make sure you collect all data necessary to prepare a realistic tender or plan. The following checklist is meant to assist you in your site inspection:

Original Track / Road Condition:

What is the existing condition of the track or road before construction or rehabilitation work commences in comparison to the required standards?

- For new construction:
 - how is the topography; flat, hilly, mountainous?
 - which are the soils along the new road?
 - are there problematic sections, e.g. rock, swamps, forest, steep gradients, etc.?
 - could there be problems with private land owners where the road will interfere with their land?
 - how are the site conditions for structures?
 - are there sections where erosion could be a particular problem?
 - are there potential problems with existing traffic?

- For rehabilitation or regravelling:
 - drainage; existing, open or blocked? sufficient mitre drains ? culverts in place? drainage gradients correct; scour checks in place?, etc.
 - camber; is the gradient sufficient or does it need to be improved?
 - roughness of carriageway; is heavy reshaping required?
 - structures; are the structures in good condition or do they require repair work?
 - is there any gravel left on the carriageway? if yes, how much?
 - where are the trouble spots of the road and of what nature are they?
 - is there soil erosion along the road caused by water running off the road and what must be done to avoid it?

Camp Site and Labour:

- Where are the best locations for site camps; considering distance to site, water availability, access to market and health centres, security, etc.?
- How many camp sites are required; at any one time, do you need to shift camp sites during the work, how many times?
- Is any preparation work required for the camp, e.g. access road, bush clearing, etc.?
- What is the average walking distance for the labourers, a.) from their homes to the camp, and b.) from the camp to the sites (gravelling site, quarry, reshaping site)?
- What is the availability of skilled/unskilled labourers?
- Can you get support from the local authorities to recruit and organise labour?
- Who are the people "who matter" in the area of your operation?
- What is the transport distance from the company's base to the camp?
- What mode of transport is required and how many trips (camp facilities, tools, fuel, spares, material, supervision, payments, etc.)?

Quarry:

- How much gravel is available in the particular quarry? Assess the volume of gravel that you can get from the quarry and compare it with the gravel volume you need for the road or section of road to be gravelled from this quarry. Try to estimate the thickness and area of the gravel deposit. You probably need to dig some test holes and carry out tests in a systematic manner.
- Is the quarry located in low-lying terrain? Low-lying quarries may well become unworkable when it rains.
- Does the quality of the gravel match the contract specifications?
- Is water available at or near the quarry site?
- How much of an overburden will have to be removed to reach the gravel material and where can it be deposited (hauling distance from quarry to depot)?
- Is the land owned by the client? Will there be a charge for its use? If it is owned by a local landowner, how much compensation will have to be paid? There are usually established procedures for compensation and standard prices. You can normally obtain advice and data from the client, since you both have an interest in getting good material at a reasonable cost,
- Is there a danger of soil erosion when you exploit the quarry and what would be the required protection work? For example filling of the quarry with overburden at the end of the job, etc.

Quarry Access:

- What is the length of the access road that you need to construct or improve and through what type of terrain does it run?
- How much work needs to be done to improve the access road so that the hauling can be carried out undisturbed? Try to estimate the required work input and the relevant costs.

Hauling:

- What is the average hauling distance for this job (there could be more than one quarry)? Definition: The average hauling distance is the distance from the quarry to the middle of the closest and furthest road section that you need to gravel.
- What is the condition of the haul route when improved (gradient, roughness, river crossings, soil, etc.)?
- Can your equipment be used for hauling on this particular haul route?

Compaction:

- Where can water be collected for compaction?
- How is the condition of the access road to this place and what improvement work is required?



It is useful to prepare a sketch, especially when you have to operate from more than one camp and/or more than one quarry. This can be a simple strip map with the most important data included.

Example of Strip Map:

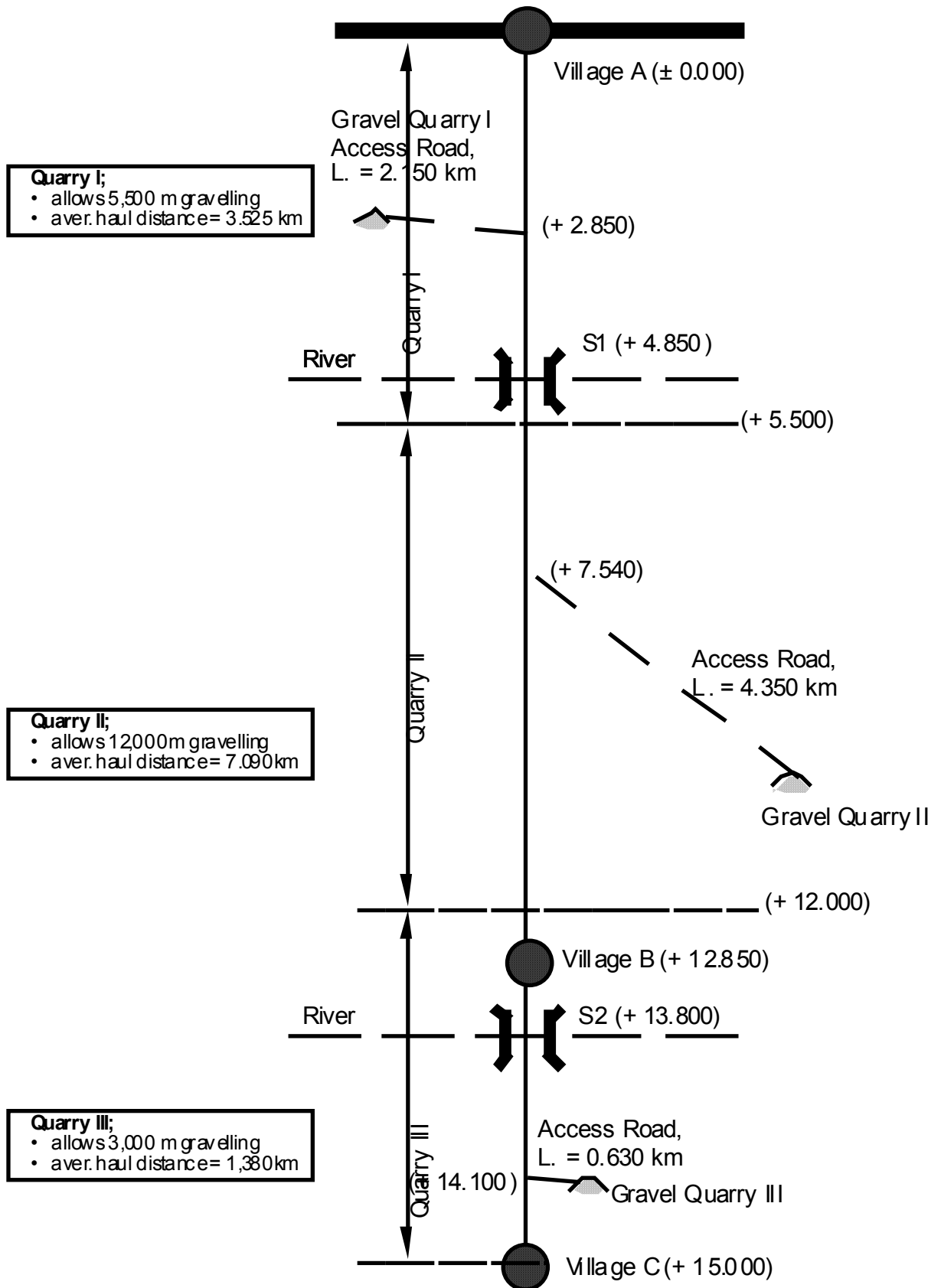

Checklist for common l.b. construction operations and activities:

OPERATION	ACTIVITY
Support	<ul style="list-style-type: none"> • setting out alignment • work at camp • water supply • erosion protection
Site clearing	<ul style="list-style-type: none"> • setting out of detailed activities • bush clearing • grubbing • tree and stump removal • boulder removal
Earth work	<ul style="list-style-type: none"> • excavation and filling • spreading • intermediate compaction
Drainage	<ul style="list-style-type: none"> • ditching (side drains, mitre drains, catch water drains) • sloping and back sloping • camber formation • final compaction • culvert installation • ditch erosion controls
Structures	<ul style="list-style-type: none"> • multiple line culverts, drifts, bridges, (large structure work to be carried out at a separate site with specialised personnel)
Improvement of quarry access road (if necessary)	<ul style="list-style-type: none"> • improvement work to allow the respective equipment to pass (continuous process during gravelling work)
Quarry preparation	<ul style="list-style-type: none"> • opening of quarry (removing of trees, crops, etc. removing overburden) • excavation and stockpiling of gravel
Road preparation	<ul style="list-style-type: none"> • re-shaping of road according to the desired standards • carrying out small repair work, e.g. washouts, culvert replacement
Quarry work	<ul style="list-style-type: none"> • excavation and stockpiling of gravel
Hauling	<ul style="list-style-type: none"> • hauling of gravel from quarry to road
Road Work	<ul style="list-style-type: none"> • re-shaping of road (if required) • off-loading of gravel • spreading and compaction • (provision of gravel stacks for maintenance)

Annexes:

1. Labour Input Estimates
2. Equipment Input Estimates
3. Work Programme and Report for Labour
4. Daily/Weekly Plan and Report
5. Example of a Musterroll
6. Example of typical Store Forms

MODULE O:

CONTRACT PROCEDURES

0.1	General	0-1
0.2	Contracting Parties	0-2
0.3	Contract Documents	0-2
0.4	Tender Procedures	0-3
0.5	Contract Implementation	0-5
0.5.1	Mobilisation	0-5
0.5.2	Contract Supervision	0-8
0.5.3	Contract Administration	0-10
0.5.4	Dispute Procedure	0-12
0.6	Demobilisation	0-13
0.7	Maintenance Period	0-15
0.8	Post Construction Evaluation	0-17
0.8.1	Records	0-17
0.8.2	Productivity and Cost Control	0-17

O.1 INTRODUCTION

Construction and maintenance projects and programmes are more and more carried out by the private sector. This requires well-established and managed contract procedures and documentation. This module deals mainly with contracting of construction projects. Maintenance work are often smaller and simpler procedures and documentation may be appropriate.

Any construction project can be divided into various stages reaching from the initial idea to the final handing over to owner and/or users. Four main stages (or phases) may be convenient for the different management activities, namely:

Stage	Activities and Management Teams
<i>Briefing</i>	These are the preparation activities, which the client has to carry out to identify the project. For roads these could be: road network identification, road inspection, surveys, priority setting, preliminary plans and cost estimates, etc. These activities are usually carried out by the client's own staff or by hired consultants. After the preparation has been carried out the client will have to seek approval for detailed planning and implementation.
<i>Designing</i>	Detailed planning consists of a number of activities that follow each other in a logic sequence: 1.Road Appraisal; 2.Field Assessment; 3. Preparation of Designs / Plans; 4.Preparation Tender Documents; 5.Invitation to Tender; 6.Issue of Documents; 7.Pre-tender Site Visit; 8.Tender Notices; 9.Submission of Tenders; 10.Tender Evaluation; 11.Evaluation Approval; 12.Preparation of Contract Documents; 13.Notification of Award; 14.Order to Commence. These activities are dealt with either directly by the client or by hired consultants. Contractors are involved in the process as from the 4 th activity (invitation to tender).
<i>Constructing</i>	Constructing means actual implementation of the works as per the contract and includes all steps from the moment of order to commence works until completion of the job. This is the stage where the contractor is the main actor. Works are supervised either directly by the client or through a hired consultant.
<i>Commissioning</i>	Commissioning stage represent the maintenance phase for the works, i.e. the stage when the contractor finalises his obligations under the contract and the Client prepares to take over the responsibility for maintaining the works from the contractor. By the end of the maintenance period the road shall be delivered to the client in the condition required by the contract with allowance for fair wear and tear. As for the construction stage the contractor plays a main role.



Comprehensive details of these 4 stages are described in the Contracting Manual for Labour Based Road Rehabilitation Work of the Ministry of Supply, Zambia.

The following sections provide an overview of those issues that are particularly important for a contractor to manage his/her contract. For general contract management issues refer to the above-mentioned manual.

O.2 CONTRACTING PARTIES

For conventional contracts the different parties have distinct roles and responsibilities:

- The **Client**, either an authority or private, makes an agreement with an Engineer (consultant) or Contract Manager to design a project and to manage the contract. The client funds the project and retains the overall control. On site, an Inspector who ensures that all parties adhere to their responsibilities and who directly represents the client's interests, represents the client.
- The **Engineer/Contract Manager** is usually a consultant and is in charge of designing and supervising the project on behalf of the client. For large projects, design and supervision is carried out by different consultants while in the case of smaller projects these work is often carried out by the client's own staff.
- An established **Contractor**, who is usually selected through a normal tendering process, carries out the work. The contractor is responsible for the execution of the work. On site a **Site Agent** usually represents the contractor.
- The contractor hires **Labourers** for the labour activities. Very often labourers are employed on casual terms, which means they can be hired and fired as required. A simple contract between the contractors and the labourer regulates the employment conditions.

O.3 CONTRACT DOCUMENTS

The Tender Documents provide all the legal and technical information to the tenderers, which will enable them to submit valid and competitive tenders and enter into contract with the client for provision of the works as specified in the contract. It is important to realise that "the contract" is a two-way relationship with rights and obligations by both parties to the contract. The responsibility of the Client starts with the specification of:

- What he wants ("the Works");
- The quantity and quality of the Works to be provided ("BOQ", "Specifications");
- How he wants the Works to be provided (e.g. use of labour-based methods or equipment);
- Who may provide the Works ("eligible tenderers");
- How the eligible tenderers may offer their services ("Instructions to Tenderers" and "Forms of Tender");
- Guarantees that the offers given are serious ("Tender Bonds");
- Guarantees of value for money ("Advance Payment Bonds", "Performance Bonds"); and
- The regulations to govern the provision of the works ("Conditions of Contract").

The full set of Tender Documents for **labour-based rehabilitation contracts** in Zambia includes:

- Volume I,** Section 1: Instruction to Tenderers
Section 2: Forms of Tender, Qualification Information, Letter of Acceptance + Agreement
Section 3: Conditions of Particular Application
Section 4: Contract Data and Schedules
Section 5: N/A for Volume I
Section 6: Tender Drawings
Section 7: Bills of Quantities
Section 8: Security Forms
- Volume II,** Section 3: Conditions of Contracts
Section 5: Specifications
Section 6: Standard Drawings

The full set of Contract Documents for the **routine maintenance performance contract** consist of the following sections:

- A1. Instruction to Bidders
- A2. Bidding Data
- B. Forms of Bid, Qualification Information, Letter of Acceptance and Agreement
- C. Conditions of Contract
- D. Contract Data
- E. Specifications
- F. Maps / Drawings
- G. Works Schedule

Both documents have been specifically developed for the use of labour-based methods.

O.4 TENDER PROCEDURES

Standard procedures for procuring contractors and to manage contracts are as per the following table.



For details refer to the Contracting Manual for Labour Based Road, Section E

Step	Explanation
<p>1. Pre-qualification</p>	<p>This is an invitation, usually in the press, for contractors to bid for a contract. Contractors may be short listed for an invitation depending on their past record or any other specific conditions/ criteria which the client may prefer, e.g. contractor must be from a certain location, or have a certain size, etc. Interested contractors have to submit records of past experience, previous clients, present staff, present plant and equipment fleet, current and future commitments, financial strength, etc.</p>
<p>2. Notice of Tender</p>	<p>The contractors who meet the pre-qualification criteria are identified and listed. The successful contractors receive the notice to collect tender documents against payment or a tender deposit. The deposit will not be returned to contractors who fail to submit their tender.</p>
<p>3 Instructions to Tenderers</p>	<p>Instructions are given together with the tender documents and may consist of: instructions on how to complete the tender / address and time for submission / procedures on how to submit alternative tender, amount of security (as a bank guarantee) / declaration of tenderer's obligation of a site visit / information on supplementary documents available / etc.</p>
<p>4. Tender Period</p>	<p>The tender period for labour-based contracts is usually four weeks. (For larger contracts the period is usually three months). Clarification of tender can be sought during the tender meeting when the bidding documents are issued or in writing at any time during the tender period. During the tender period the following activities need to be carried out:</p> <ul style="list-style-type: none"> • Pre-tender site visit to clarify details and conditions on site • Issue of tender notices containing additional information for tenderers by the client • Preparation of a preliminary work programme by the contractor • Estimation of resource requirements in terms of labour, material, equipment and cash flow to be provided as part of the tender by the contractor • Pricing of all work items (Bill of Quantity)
<p>5. Tender Opening</p>	<p>Tenders have to be submitted in sealed envelopes and on the date and time specified in the instructions to tenderers. The submitted tenders are usually opened immediately in the presence of the tenderers who wish to participate. The total sum of each tender is read including the statement that the tender bond is in order (or not).</p>
<p>6. Tender Evaluation</p>	<p>The appointed engineer or the client scrutinises the tenders and prepares an evaluation report. The following evaluations are made: arithmetical checking of BQ / checking for any unacceptable reservations or conditions / evaluating alternative tenders (if any) / evaluating foreign currency requirements / evaluating the work programme and construction methods / evaluating the proposed equipment to be used / checking the degree for subcontracting and qualifications of subcontractors / checking for unbalanced tender / comparison of tender sum with Engineer's estimates. The evaluated tenders and the recommendations are forwarded to the tender board for final evaluation and selection of the successful contractor.</p>
<p>7. Winning Tender → Award of Contract</p>	<p>Usually the lowest tenderer is selected. A letter of acceptance is issued to the winning tenderer after the client has accepted the evaluation report. The contractor must produce a bank guarantee (usually 5% of tender sum) when signing the contract. After the contract is signed, the Engineer issues an order to start work.</p>

O.5 CONTRACT IMPLEMENTATION

Upon signing of the contract, the Conditions of Contract come into force. Both parties must now make arrangements to fulfil their obligations and protect their interests under the contract.

CLIENT	CONTRACTOR
Obligations	Interests
Efficient project and contract management <ul style="list-style-type: none"> - Ensure contractor's access to the site - Secure adequate cash flow and payment procedures - Promptly communicate decisions and information pertaining to the contract 	Realise the profit from the contract <ul style="list-style-type: none"> - Be able to work as planned - Be paid on time - Be informed of decisions and conditions pertaining to the contract
Interests	Obligations
Fulfilment of project objectives <ul style="list-style-type: none"> - Be informed on progress and actions taken by the contractor - Good quality of the Works - Delivery on time - Delivery at contract price 	Efficient construction and contract management <ul style="list-style-type: none"> - Adhering to specifications - Effective planning and site management - Promptly act on decisions and other information received - Provide adequate warning on technical and other problems pertaining to the contract

O.5.1 Mobilisation

A mobilisation period of one month is common for rehabilitation projects. The duration should, however, be based on the actual need of the contractors, at the discretion of the Client, and be specified in the Contract Data.

Both parties must utilise the mobilisation period to finalise arrangements, which could not be completed before signing of the contract or are still outstanding. The following two checklists provide an overview of the mobilisation task to be carried out.

MOBILISATION TASKS BY THE CLIENT		
Task	Purpose	Checks and Requirements
Effect Advance Payment	Enable contractor to mobilise	Advance Payment Bond, money available
Information to local communities	Contractor's mobilisation and contract execution	Communities to be briefed on start of construction, labour-based works, employment conditions etc.
Prepare and issue construction drawings	Contract execution	Design, details etc. not provided on standard or tender drawings
Mobilise project staff	Project management	Qualifications, terms of employment, housing, transport
Open separate Project Bank Account	Control of project funds	Provide two authorised and backup signatories
Ensure sufficient cash flow, streamline payment procedures	Efficient contract execution	Limit the number of steps and signatories, provide backup signatories. Set up internal management reports to avoid queries and delays.
Review or set up accounting system	Control of project funds and payments under each contract	System must capture the costs for each individual contract as well as related costs for consultants etc.
Set up filing system	Accessibility and safekeeping of all contract related correspondence, documents and records.	One file number per contract divided in sections as required. To be kept in locked steel cabinet.
Reporting and Monitoring System	Control of project management and contract execution	Internal and external reporting and monitoring to capture all aspects of project.
Schedule of meetings	Dissemination of information, discussion and resolution of problems	Project co-ordination meetings, site meetings, staff meetings,
Quality control procedures	Control of contract execution	Acquire equipment and recruit staff, arrange for testing at laboratory.
Roles and functions of staff	Efficient project management	Draft and approve job descriptions
Transport	Supervision	Buy or hire pick-ups, motorbikes
Office space	Project management	Standard office inventory, communications, PC(s), copier, stationary
Site facilities	Supervision	Store, tools and equipment
Access to site and quarries	Contract execution	Quarry acquisition, handing over site to contractor

MOBILISATION TASKS BY THE CONTRACTOR

Task	Purpose	Checks and Requirements
Provide Advance Payment Bond	Enable mobilisation	Insurance policies, dedicated bank account
Provide Insurance Policies	Enable mobilisation	Information to insurance company, money for payment
Finalise cash flow analysis and financing arrangements	Enable mobilisation and construction	All requirements taken into account: Overheads, staff, labour, materials, tools, equipment, transport, interest payments, equipment lease/hire etc.
Take possession of site	Enable site establishment	Ensure that client has fulfilled his obligations
Mobilise office and site staff	Project and site management	Qualifications, terms of employment, housing, transport
Recruit labourers	Contract execution	Information to local leaders
Open dedicated Project Bank Account	Control of contract proceedings	Provide authorised signatories
Review or set up accounting system	Control of contract proceedings and payments	System must capture all costs and enable cost breakdown on bill items and costs components
Set up filing system	Accessibility and safekeeping of all contract related correspondence, documents and records.	One file number per contract divided in sections as required. To be kept in locked steel cabinet.
Reporting and Monitoring System	Control of project management and contract execution	Internal and external reporting and monitoring to capture all aspects of project.
Schedule of meetings	Dissemination of information, discussion and resolution of problems	Project co-ordination meetings, site meetings, staff meetings,
Quality control procedures	Control of contract execution	Acquire equipment and recruit staff, arrange for testing at laboratory as required.
Roles and functions of staff	Efficient contract management	Draft and approve job descriptions
Acquire equipment, transport	Contract execution and supervision	Finalise arrangements for procurement, lease or hire
Purchase tools, materials	Contract execution and supervision	Finalise arrangements for supply
Office space	Contract management	Standard office inventory, communications, PC(s), copier, stationary
Site facilities	Contract execution and supervision	Site camp, office, workshop, store

O.5.2 Contract Supervision

Supervision of the contract works is carried out either directly by the client's staff or by an appointed consultant. It is important for a contractor to know what the supervision activities are.

Supervision Issues:

Technical Issues – ensuring that the contract works are executed in accordance with the standards and specifications.

For labour-based rehabilitation, the following requires special attention:

- **Setting out.** If the setting out is poorly or inaccurately done, the standards will not be achieved and the actual quantities may differ substantially from the quantities in the BQ;
- **Drainage features.** Adequate drainage is the most important aspect of earth and gravel roads and must be provided for in the initial setting out of the horizontal and vertical alignment, including position of cross drainage structures and outlets;
- Properly shaped and compacted **road camber** before application of the gravel layer;
- **Quarry excavation** to ensure use of only approved material and minimal in mixing of topsoil or other unsuitable material;
- **Gravel layer** thickness and compaction in accordance with standards;
- **Quality of concrete** works;
- Quality and position of **erosion protection measures**. Poorly executed work will soon collapse or cease to function as intended during heavy rains and strong water flows.

Quality Control - covers all technical aspects of supervision. Records must be taken systematically and filed for later reference. It is the supervisor's duty to alert the contractor about deviations from standards and specifications as early as possible to avoid repetitions and compounding of the problems.

Timing – ensuring that the contract works are delivered within the specified time. Performance charts comparing the actual progress with the planned should be up-dated on a monthly basis. Explanations and plans to remedy the situation should be sought when the progress is significantly slower than planned. Strict control of the technical and quality issues contribute to alleviation or avoidance of time related problems.

Financial Issues – ensuring that the works are delivered to the agreed tender price including allowance for contingencies. The control of the technical and time related issues influences the contractor's financial performance. The actual control of the project finances is carried out through the accounting system.

Management Issues – ensuring that the contractor is managing the contract, his/her site, staff and labour force in accordance with best practices and prevailing labour standards. Of particular importance for labour-based works is the contractor's adherence to international / national labour standards. Clauses to govern these issues should be included in Conditions of Particular Application to protect labourers and staff from exploitation, discrimination, favouritism and denial of basic rights. The Inspectors should closely monitor and keep records on: General work organisation; Setting of task rates; Issue of hand tools and their quality and maintenance; Late- or non-payment of staff and labourers;

Supervision Activities:

Site Inspections- the most important means of maintaining control with the execution of the works. Only by seeing the problems first hand can the course of action be agreed upon and directives be given after discussion with the contractor's site staff. Site Inspections must be carried out at least on a weekly basis, sometimes more frequently, depending on the phase of construction and the possible difficulties for the contractor.

Site Instructions - the contractor's Site Agent should be instructed to maintain a Site Instruction Book in which all the instructions given to him/her is recorded and signed by the one giving the instructions. The book should be in the form of a triplicate booklet, the original to be given to the contractor, one copy to the Project Manager for action and filing and the second copy to remain in the book for the Supervisor to follow-up on the instructions.

Site Records - for day-works and non-standard activities, accurate site records must be maintained to prevent disputes during measurement. The Project Manager should define the limits of non-standard and day-works which the Inspectors can approve, all within the provisions in the Bill of Quantities.

Site Meetings - regular Site Meetings, e.g. on a monthly basis, should be held and chaired by the Project Manager. The purpose of the Site Meetings are to provide a collective forum for discussion of problems and dissemination of information and thereby saving time and effort as well as minimising the possibility of information and resolutions being misconstrued by passing through several levels in the organisation. Both parties should be represented by responsible contract managers, senior management staff, site staff and external personnel as appropriate.

Minutes from the Site Meetings should be compiled and distributed immediately after the meeting and should contain:

- Time and venue for the meeting
- Project Name / No
- People present with Name/Title/Organisation
- Concise records of the resolutions made and information disseminated
- Points of Any disagreement by either party
- Responsible person(s) and deadlines for actions to be taken.

Work Approval - Work should generally be approved without undue delay, especially where further progress depends on the approval of the completed parts of the works, e.g. for gravelling of completed sections of road formation and covering up of concrete works.

The approval of completed works or parts of the works must be recorded on Site Records and signed by the responsible Engineer/Inspector.

The Engineer/Inspectors must check that the contractor maintains all completed portions of the works its approved condition until the subsequent step is commenced. For instance, when the formation has been checked for conformity with the specifications and approved, it must be maintained in perfect condition, i.e. in terms of width, camber, evenness and compaction, until the gravel layer is applied. (This maintenance should not be confused with the maintenance during the Defects Liability Period that commences once the work is declared substantially complete)

Variation Orders - are orders to vary the works by:

- Making changes to or the timing or sequence for part of the Works;
- Omitting part of the Works;
- Specifying additional work, or
- Changing the specifications.

Only the Project Manager can issue Variation Orders, but the contractor may request a variation of the works. The total of all Variation Orders must be within the contingency amount for the contract unless authorisation has to be obtained from the Client.

O.5.3 Contract Administration

Measurements of Work - the contractor is normally responsible for preparation of monthly statements of completed works to be submitted for approval by the Project Manager. For inexperienced contractors, however, a more practical approach, which both saves time and prevents disputes on the quantities certified for payment, is to prefer. Under this approach the contractor will request the Project Manager for measurement to be undertaken within one week's notice.

The Contractor and the Project Manager (consultant) in the presence of the Site Agent (of the contractor) and the responsible Inspector (representative of client) will then do the measurement jointly. The quantities of completed and approved work are then recorded on the Take-off sheets and signed by both parties as being a true record of the measurement. The arithmetic details of the measurements must be recorded on the Take-off sheets for later reference and correction of possible errors.

Preparation of Interim Payment Certificates - is the responsibility of the Inspector.

- The monthly PCs are prepared on the basis of the Take-off sheets and submitted to the Project Manager for approval, normally not more than two to three days after the measurement.
- The Project Manager should sign and give the date for his approval. This date will be the basis for any claims arising from delayed payments by the Client.
- The Payment Certificate is forwarded to the accounting section, which will prepare the payment voucher and cheque for payment to the contractor.

The procedure from the date of measurement until the cheque is prepared and signed should under normal circumstances not take more than 5 to 6 working days.

In the event that the Project Manager has been notified of claims against the contractor, and if these are found to be genuine and related to the execution of the contract, the amount of the claims may be deducted from the payment to the contractor and used to settle the claims.

In particular, if the contractor is found guilty of not paying the labourers and his staff on time, the Project Manager may exercise his powers to pay directly from the amount due to the contractor for works done.

Deduction of Retention Money - is meant to cover the Client's costs for completion of outstanding works or rectification of works not done according to specifications. The Retention Money is specified in the Contract Data as a percentage to be deducted from the value of the works approved for payment and as a maximum of total money that can be retained. The percentage is normally set to 10%, which is deducted from each interim payment certificate. The retention is paid back to the contractor if all works have been carried out to the satisfaction of the client and after successful final inspection.

Evaluation of Claims - When progress falls behind schedule or the contractor's costs in completing the works becomes higher than he/she had allowed for in the tender, the contractor may consider submitting a claim for:

- extension of time to be able to complete without penalties; or
- additional payments to cover his costs; or
- both of the above.

The importance of keeping accurate records, and in particular records of all obstructions and conditions on site or those which may otherwise affect the execution of the contract, then becomes apparent; for the contractor to substantiate his claim and for the Project Manager to assess the validity of the claim.

The handling of a claim, or the probability of a claim being accepted, should be understood on the background of how the risk element is treated in a contract. By accepting the risk allowance in the tender price, the Client has in effect transferred to the contractor the risks for "obstructions or conditions that should in his (the Project Manager's) opinion reasonably have been foreseen (by the contractor)".

For gravel road rehabilitation, some possible claim situations and factors for their assessment are listed in following table.

When a claim has been made, both parties must agree and make detailed records of all facts and circumstance relating to the claim, or in the event they cannot agree, make their own separate records as well as recording the reason for disagreement.

Possible Claim Situations and Factors for their Assessment	
Reason for Claim	Factors to Consider
Ground conditions more difficult than expected or specified in the contract, e.g. soil is claimed to be hard to excavate when described as medium or soft)	<ul style="list-style-type: none"> • How easily could the contractor have assessed the situation during tendering? • Has the contractor issued good quality tools for the job? • Has the contractor organised the job well?
Adverse weather conditions, i.e. persistent or intense rain	<ul style="list-style-type: none"> • What is the normal rainfall in terms of mm/year or mm/day? • Has accurate rainfall data been kept? • How much or what parts of the works suffered damage? • Has the contractor adequately protected his work?
Labourers go on strike	<ul style="list-style-type: none"> • Did non-payment or other actions/omissions by the contractor cause the strike?
Handing over of site or access to quarries not finalised on time	<ul style="list-style-type: none"> • Was there no alternative work that could have been done while waiting for access without causing operational difficulties, extra costs or risks for the contractor?
Water for compaction not available at specified location	<ul style="list-style-type: none"> • Has the contractor obtained the required permission from the owners/users of the water source? • Has the contractor sought for alternative sources within the same hauling distance?
Information not provided, on time or not at all, by the Client	<ul style="list-style-type: none"> • Was the information really crucial to the contractor's progress? • Could the contractor have done other work while waiting for the information?
Late payments by the Client	<ul style="list-style-type: none"> • How long was the delay in payment? • Should the contractor have been able to continue operations with his own working capital?

Enforcement of Liquidated Damages - based on the judgement by the Project Manager, the Client may decide that the contractor is at fault for delayed completion if the conditions causing the delays were deemed not to be beyond the control of the contractor or within what should have been reasonably foreseen by him. For such delays the contract will specify the amount to be paid by the contractor, usually with a fixed amount per day the completion is delayed beyond the agreed completion date, i.e. the completion date as specified in the contract data plus any extension of time that may have been granted.

The purposes of the liquidated damages are:

- As a deterrent to the contractor for working behind schedule;
- To compensate the Client for the delayed use of the Works based on the value assigned to this use;

Hence liquidated damages are yet another way for the Client to reduce its risks. These are specified in the Tender Data and should be taken into account when the contractor decides on his/her risk allowance.

The Client will usually determine size of liquidated damages based on:

- The size of the contract; and
- The value to the Client of using the Works;

For labour-based rehabilitation contracts, however, the experience and financial standing of the contractor are also taken into consideration. It is in any event not in the interest of the Client to cause contractors to go bankrupt. The contract data will therefore also specify a maximum amount of liquidated damages that can be charged to the contractor under the contract.

0.5.4 Dispute Procedures

A contractual dispute occurs when the contractor does not agree with the final decision by the Client and should be resolved in accordance with procedures specified in the Conditions of Contract.

The resolution of a contractual dispute may be a costly and time-consuming affair for both parties. All efforts should therefore be taken to reach an amicable settlement. Failing this, a procedure in two steps is normally recommended and specified in the contract before the matter may eventually be brought before the court.

For both parties in a contractual dispute it is important to be aware of the formal requirements:

- Time limits for rejection of decisions and referral of the dispute to a higher level;
- All communication to be in writing and with notice to the other party.

Failure to comply with these formal requirements will in itself result in a lost case and the decision to be declared “final and binding” on both parties.

Adjudication - the parties may appoint an Adjudicator (or Conciliator), by common agreement, the particulars of whom must be specified in the Contract Data. The Adjudicator can be any person who is regarded by both parties as being neutral and having the required knowledge and experience to make a fair decision for the resolution of the dispute.

The services of the Adjudicator are not free of charge and the payment is to be specified in the Contract Data. However, if the dispute can be resolved at this level, the cost to both parties in monetary terms as well as in time and effort will be relatively limited.

Adjudication is normally conducted by means of negotiations whereby the Adjudicator attempts to bring the parties to agreement after having studied the relevant facts and hearing each party's arguments. The procedure relies much on the Adjudicator's negotiating techniques and impartial conduct.

Either party can bring the dispute to the attention of the Adjudicator and likewise choose to accept or reject the Adjudicator's decision.

When a decision is rejected, the dispute is referred to arbitration.

Arbitration - the arbitration procedure is laid down in the Conditions of Contract, usually by reference to a law or Arbitration Act. Arbitration is a more formal and comprehensive procedure than adjudication. The parties are therefore better advised to settle the dispute before it comes this far unless considerable gains or losses are at stake.

If the parties still fail to reach an agreement as a result of arbitration, they may refer the matter to the court.

O.6 DEMOBILISATION

An orderly scaling down of activities and demobilisation from site, require good planning and supervision by the site staff, as there are many diverse activities, usually spread over the whole project location, to be undertaken. The demobilisation tasks come in addition to the finishing activities of the works and include:

Demobilisation Tasks:

- Giving notice to labourers as the labour force is scaled down for termination of the temporary employment in accordance with labour regulations;
- Settling accounts for suppliers and utility services;
- Taking down temporary works used in the construction activities and for the camp and site facilities;
- Re-instating areas used as close as possible to their original condition;
- Collection and stocktaking of tools and equipment;
- Maintenance, repair and removal of construction equipment from site;
- Planning and preparations, including training, for maintenance during the Maintenance Period.

Completion Works - When the works are close to being completed the contractor must ensure that outstanding works which affect the functionality and safety of the road or the function of the drainage system are completed in accordance with the specifications. Such works may include:

- Erection of Road Signs;
- Finishing of Culvert Headwalls;
- Finishing of erosion protection measures in drains;
- Correction of defects on the carriageway or in the drains;
- Clearing and removal of debris for sight distance;
- General road maintenance to bring the whole road up to the same condition;

Other works which are not directly affecting the road users, may be finished at a later stage, such as:

- Grass planting in slopes;
- Restoration of quarries;
- Removal of site facilities and cleaning up in and around the camp;

Substantial Completion - Having completed all essential tasks the contractor will request the Project Manager to undertake the inspection for substantial completion. During this inspection all defects and outstanding works are noted and time limits given for the contractor to correct or carry them out.

- If the Project Manager finds that the road has been substantially completed, he will issue a Completion Certificate to that effect with the inclusion of the list of defects and outstanding works. The road is then handed over to the Client and the Maintenance Period or Defects Liability Period begins.
- Substantial Completion means that the Client can make use of the works in accordance with the objectives and that there are no significant defects or essential parts of the works missing. In practice though, on a labour-based rehabilitation project, traffic will run on the completed sections of formation and gravel even before these are handed over since it is deemed too costly to construct detours.
- Sectional completion and handing over can therefore be considered for larger projects to avoid excessive traffic damage during the construction period and possible disputes. Completion Certificates should then be issued for sub-sections, which have been substantially completed. If requested by the contractor, the Project Manager must issue Completion Certificates for such substantial parts of the works, which have been occupied or used by the Client. For each such sub-section the Maintenance Period will run from the date of issue of the Completion Certificate for that particular section.
- On the Completion Certificate all moneys due to the contractor for works done will be calculated similarly to the interim certificates. On this certificate, however, deduction for retention will not be made.

Handing Over The Works - During the inspection for substantial completion, representatives from the Client and other stakeholders should be present for the formal handing over of the works. Similarly partial handing over may be done for portions or sub-sections of the works.

Final Inspection - At the end of the Maintenance Period the contractor will request the Project Manager to undertake the Final Inspection. Provided that all outstanding works and correction of defects as noted on the Completion Certificate have been carried out to the satisfaction of the Project Manager and the road has been well maintained, the Project Manager will issue a Final Certificate to this effect and release the remaining portion of the Retention Money.

Release Of Performance Bond And Retention Money - When the Completion Certificate has been issued, the contractor may apply for the release of the Performance Bond, which will normally be granted provided the outstanding works are not of high value or cost. Normal practice is also then to release 50% of the total retention money provided the remaining 50% is deemed to be adequate cover for any works or rectification that may have to be done by the Client. At this point therefore the 50% retention money will be the only remaining security still in force as shown in the following graph.

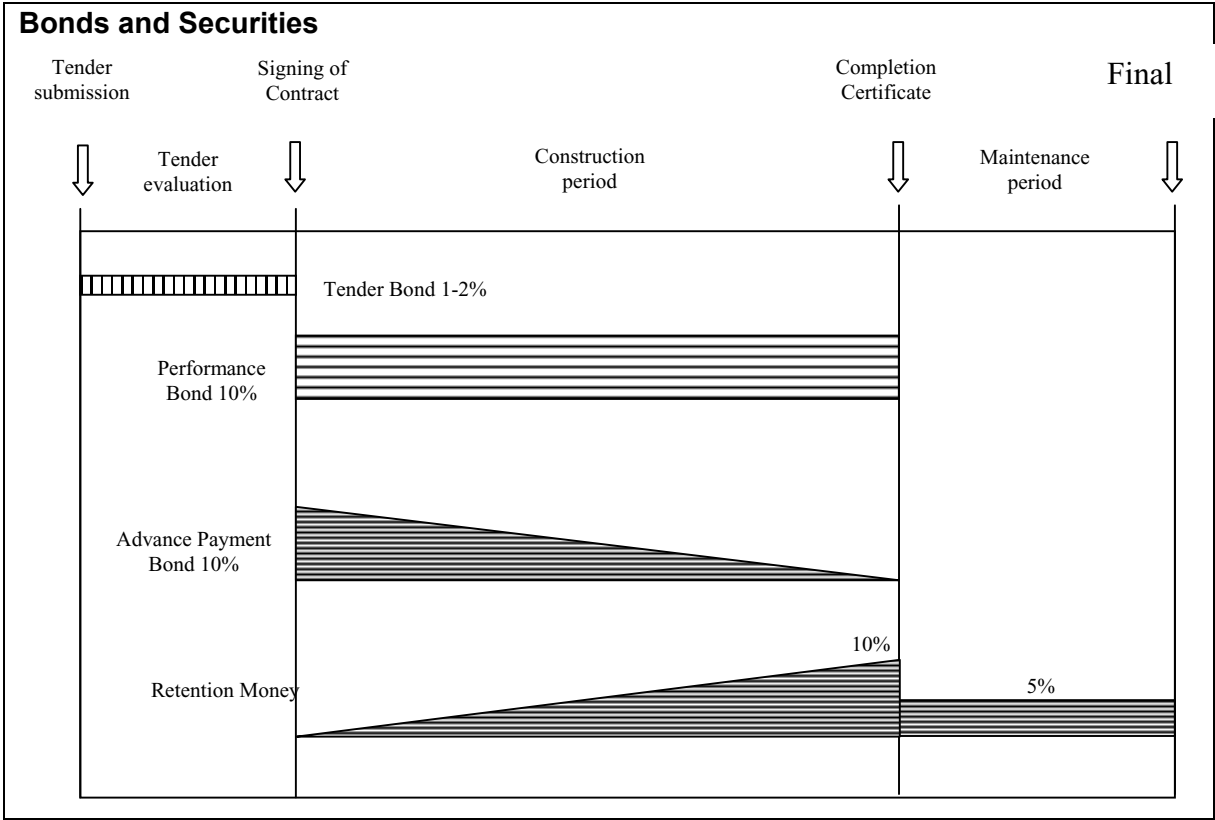

O.7 MAINTENANCE PERIOD

The Maintenance Period represents the Commissioning Stage for the works, i.e. the stage when the contractor finalises his obligations under the contract and the Client prepares to take over the responsibility for maintaining the works from the contractor. By the end of the Maintenance Period the road shall be delivered to the Client in the condition required by the contract with allowance for fair wear and tear. Note that ideally there is a change in the rights and responsibilities at the beginning and end of the Maintenance Period as shown in figure G-1.1 below:

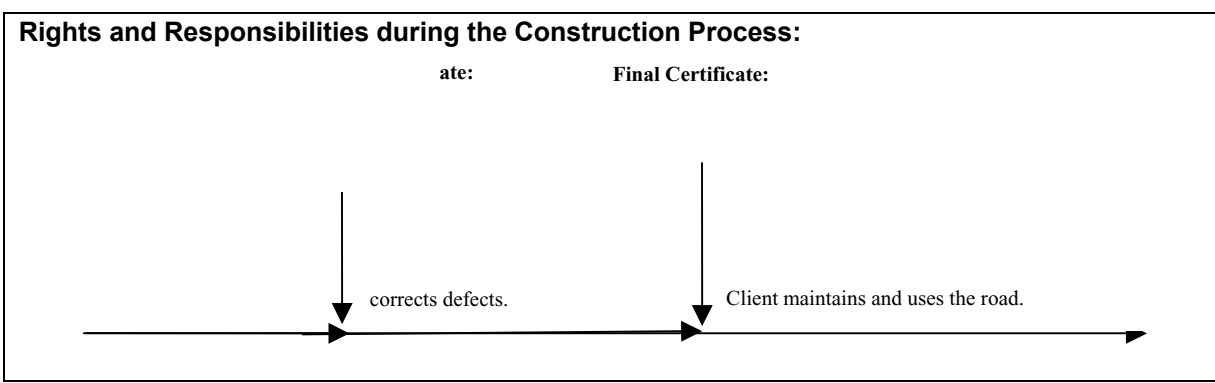

In practice though, on a rural road, it is both impractical and impossible to keep traffic off the road during the construction period, since construction of detours and bypasses would make the rehabilitation uneconomical. The contractor should therefore take this into account when pricing the works and assessing his risk allowance.

Documentation - The contractor shall submit any such documentation as specified in the contract. This may include information of importance to the Client for the final analysis of the project as well as planning and promotion of future projects, such as:

Employment data (Workerdays, broken down male and female, Wages paid);

- Productivity figures;
- Equipment utilisation records; and
- As-built drawings.

Final Certificate - The works are not considered complete until the Project Manager has issued a Final Certificate (or "Maintenance Certificate") stating the date on which the works were completed and maintained to his satisfaction. The Final Certificate should include payment for works completed during the maintenance period plus the remaining portion of the retention money and any approved claims that the contractor may have.

Maintenance of Works - The Maintenance Period (or "Defects Liability Period") for a rural, unpaved road is normally set to three months during which the contractor shall complete any outstanding works and correct defects in accordance with the conditions in the Completion Certificate. In addition the contractor shall make good any defect occurring during the Maintenance Period and carry out regular maintenance of the road.

If any works is required to be done after the end of the Maintenance Period, the Client is entitled to withhold the estimated cost of such work from the balance of the retention money until the contractor has completed it, or failing this complete the work at the contractors expense.

During this period the quality of the design and the workmanship by the contractor becomes evident. In cases where the design was apparently inadequate, e.g. by too few mitre drains or scour checks not being provided for, both of which may only be realised with the onset of the rains, the contractor should request a variation of the works to rectify these features. In any event he must report the findings and the possible consequences in order to protect his own interests.



For details on routine maintenance works refer to Module K of this Handbook.

Rectification Of Defects - The Completion Certificate will specify the defects to be corrected. These will be of a nature that does not immediately threaten the functionality of the road, in which case the road would not have been declared substantially complete, but defects that nevertheless are not in accordance with the specifications, such as:

- Defective camber;
- Uneven riding surface;
- Gravel layer too thin or insufficiently compacted;
- Insufficient cross section on outlet drains.

Even if time limits for correction of defects are not given, the contractor should try to correct them as soon as possible in order to minimise the possibility of the defects causing more severe damage to the road and thereby increasing his maintenance costs.

No interim measurements will normally be made during the Maintenance Period, meaning that works that were not approved for payment during the final inspection will not be paid for until the end of the Maintenance Period.

O.8 POST CONSTRUCTION EVALUATION

O.8.1 Records

When all construction activities have been completed, it is time for the contractor to analyse the performance on the contract. For this exercise to be successful and of any real value, accurate records of all inputs and costs must be available i.e.:

- Workerdays and wages broken down on activities and operations;
- Labour productivity;
- Material prices and consumption;
- Equipment availability and utilisation;
- Prices and consumption of hand tools;
- Running costs of equipment;
- Other incidental expenses;
- Site establishment and running costs;
- Office running costs.

The sources of information are:

- Daily and Weekly Plans and Reports;
- Muster Rolls;
- Pay Sheets;
- Invoices;
- Receipts;
- Stores records;
- Equipment Work Tickets / Log Books;
- Equipment Service Records / Job Cards;
- Payment Certificates;
- Bank Statements;
- Books of Accounts;
- Instructions, Variation Orders and other communication from the Project Manager.

O.8.2 Productivity and Cost Control

It must be the aim of any business minded contractor to achieve the contracted work at minimal costs. In order to reach this primary business goal it is essential to have an effective productivity and cost control system in place.

There are three basic objectives for productivity and cost control:

1. Identification of **differences between targets and achievements** in order to arrange for corrective measures if required,
2. Results to use for **claims and for preparing the invoice**, and
3. Results to be used for the **preparation of bids** for new jobs.

Productivity control is the comparison between targets and achieved results in terms of worker-hours, equipment-hours and quantities of material compared to the achieved quantity of work. For example a productivity rate for manual excavation is m³/day or hour.

It is advisable to check for each work item the achieved productivity rate and to compare it with the assumptions that were made when tendering for the job and preparing the work programme. This should be done on a **daily basis** for at least the major items so that effective corrective measures can be made if required. It is especially important to analyse daily those items which are mainly executed with equipment, like excavation and earth movements.

For effective productivity control it is necessary to have in place a **daily reporting system** where for all work items the used resources and the achieved productivity rates can be recorded and calculated (see sample form next page). The results from the filled daily forms can then be compared with the set targets in the workplan and the productivity rates that were assumed when preparing the bid.

DAILY SITE REPORT															
Site: <input type="checkbox"/> Structure A1		Weather: <input type="checkbox"/> cloudy, no rain		Remarks: due to late arrival of the tipper with the sand work started only at 9.00am and ended therefore late (6.00pm)											
Date: 25.5.2002		Site in Charge: <input type="checkbox"/> N. Kaunda													
Productivity	Worker		Equipment Hours						Material Consumption				Achieved <input type="checkbox"/> Productivity		
	Hours for Item	Hours Day Work	Tipper Lorry	Concrete Mixer	Vibrator					Aggregate	Sand	Cement			
Work Items										m3	m3	Kg		U	Total
5.10	Providing & laying cement concrete	64		4	8	7				5.2	2.6	740		m3	8
	1:5:10														
	Day Work Activities		2												
	Total	64	2	4	8	7				5.2	2.6	740			

For day-work separate daily reports should be filled which should outline all the resources used for the work. The form has to be approved by the Project Manager prior to use. Daywork reports have to be approved and signed within two days of the work being done and forwarded for countersigning by the Executive Engineer. Daywork may only be carried out upon a written instruction of the Project Engineer.

The daily reports have to be summarised at the end of the week and forwarded to the Site Engineer for monitoring purposes. It is the Site Engineers job to carry out the cost control on the basis of the achieved productivity rates.

It is important to precisely record the cost for the major items of work on a weekly basis. Any significant deviation from the estimated rate has to be analysed in order to arrange for effective corrective measures.

It is particularly important to also analyse the actual overhead costs as these are usually based on random assumptions when pricing for a tender. It is the Site Engineer's responsibility to keep record of the site and company overhead costs.

MODULE P:

LABO

P.1	LABOUR LAWS AND REGULATIONS	P-1
P.1.1	Introduction	P-1
P.1.2	General Labour Regulations	P-1
P.2	LABOUR RECRUITMENT AND REMUNERATION	P-3
P.3	SAFETY AND HELATH ON SITE	P-6
P.4	HIV AND AIDS	P-6

P.1 LABOUR LAWS AND REGULATIONS

P.1.1 Introduction

Labour laws and regulations are set at international and national levels.

The International Labour Organisation is the United Nation body that deals with Labour issues. Over the years, the ILO has issued for adoption by member states, of which Zambia is one, a widely respected code of international labour conventions and recommendations on freedom of association, employment, social policy, conditions of work, social security, industrial relations and labour administration, among others.

On a national level these recommendations lead to comprehensive labour laws. In Zambia these laws are regulated by Acts of Parliament, commonly known as “Labour Laws”. These laws are enforced by the Ministry of Labour and Social Security.

This Module explains common and particular regulations that are important for contractors in the construction sector.

P.1.2 General Labour Regulations

In Zambia the following Acts / Chapters constitute the Labour Laws:

- **The employment of young persons and children Act, Cap. 274**
- **The minimum wages and conditions of employment Act, Cap 276**
- **The employment Act, Cap 268**
- **The factories Act, Cap 441**
- **The employment (special provisions) Act, Cap 270**
- **The industrial and Labour Act, Cap 269**

However, laws and regulations regulating the temporary employment of workers and small contractors working in programmes of this nature are often either irrelevant or need to be developed from the ground up. The workers on employment intensive programmes basically form a new category in between the existing categories of casual worker and temporary employee, as the individual is subject to daily hire but expected to work more than one day and normally receive aggregated pay at the end of the month, and as the work is generally paid by task, i.e. the ‘pay only for work’ concept.

Actual provisions for labour-based works are usually stipulated in the contract between the contractor and the employee (see casual employment form) and also normally outlined in the contract under Special Conditions or Conditions of Particular Application.



Notice of Recruitment of Casual Labour for Road Works and Casual Employment Form for Road Works; see Annex to this Module.

In case of questions and for details please refer to the Client or the MLSS.

Some important and general applicable labour standards relevant to the construction sector are such as those dealing with:

Equality - men and women should receive equal pay for work of equal value. Persons should be given equality of opportunity and treatment in employment and occupation. There should be no discrimination against persons in their employment and occupation on the basis of their race, colour, sex, religion, political opinion, national extraction or social origin, or on any other basis set out in national legislation.

Freedom from forced labour - work or service should not be exacted from any person under the menace of penalty or under circumstances where the person has not offered himself or herself voluntarily. Work or service should not be exacted from any person:

- As a means of political coercion;
- As a method of mobilizing and using labour for purposes of economic development;
- As a means of labour discipline;
- As a punishment for having participated in strikes as a means of racial, social, national or religious discrimination.

Freedom of association - what steps can be taken to protect, respect and promote workers, employers and community's rights of association? This has to be considered:

- National laws on rights of association
- International obligations on rights of association
- Relevant associations
- Prevailing attitudes towards rights of association
- Practical impediments to the exercise of these rights
- Benefits derived by various groups if they form organizations.

Minimum age - no person under the age of 15 should be employed or work. No person under the age of 18 should be employed or work in hazardous circumstances

Minimum wages - should be established for groups of wage earners where, in consultation with employers and workers organizations, the competent national authority finds it appropriate. Minimum wages, where they exist, should have the force of law and should not be subjected to abatement; failure to pay minimum wages should be subject to penal or other sanctions.

Protection of wages - wages should be paid in cash money. Where wages are paid partially in the form of allowances in kind, such allowances should be appropriate for the personal use and benefit for the worker and his or her family, and fair value should be attributed to such allowances. Employers should not limit in any way the workers' freedom in using wages. Workers should be informed of any deduction made from wages, and national regulation should set down condition for deductions from wages. Wages should be paid regularly at or near the place of work.

Safety and health - all appropriate precautions shall be taken to ensure that all workplaces are safe and without risk of injury to the safety and health of workers. Workers shall have the right and the duty at any workplace to participate in ensuring safe working conditions to the extend of their control over the equipment and the methods of work and to express views on the working procedures adopted as they may affect safety and health.

Other employment conditions

- As a matter of principle, the forty-hour workweek is approved, and is to be applied to prescribed classes of employment.
- Employed persons should receive a holiday with pay of at least three weeks duration for one year of service. A country may set a minimum qualification period of employment for entitlement to the holiday (and rules of its calculation) but it shall be no more than six months.
- Women employed should be given special attention during pregnancy and after confinement. They should not be dismissed during absence related to confinement and maternity.
- Working hours should not ordinarily exceed eight hours in a day and 48 in a week. Workers should ordinarily have at least 24 consecutive hours rest every seven working days.

To ensure that contractors respect labour regulations, **construction contracts include contract clauses, which require contractors to apply the conditions of employment**, which prevail in the country where the work is being done. Penalties are often imposed where this provision is not respected.

P.2 LABOUR RECRUITMEMENT AND REMUNERATION

Recruitment for jobs should be conducted in a manner that ensures:

- Impartial and transparent methods e.g. lottery system/ secret ballot method.
- Not based on distinctions such as gender, political opinion, ethnic or social origins or any other criteria not related to the ability to do the job.
- No force or threat of any nature.
- Enough open publicity about impending recruitment.

Before actual recruitment exercise is conducted, publicity about recruitment for jobs should be made. This publicity should:

- Be made well in advance of recruitment through public notices (see example at end of the Module).
- Be aimed at all segments of communities.
- Give full information about the jobs and terms of employment.
- State that all male and female workers above the minimum age are welcome to apply/participate.



For “Notice of Recruitment of Casual Labour for Road Works” see Annex to this Module.

Principles of Fair Working Conditions:

- The recruitment and employment procedures that will be adopted have to be first discussed and agreed on with the local leaders (chief, politicians, women’s group leaders, others).
- Conditions of employment have to be worked out beforehand and agreed on with all parties concerned. This requires awareness of international labour laws and regulation to be applied.
- In principle, the people to benefit from project employment should be the people living within the project area. Specialised personnel like craftsmen and technicians may be hired from elsewhere if they cannot be found in the project area.

- 
- **For “Casual Employment Form for Road Works” see Annex to this Module.**
 - **It is very important that the conditions of employment are carefully explained to all labourers in a language they can understand.**

The Lottery System:

- The opening of recruitment is widely advertised by signs, word of mouth, etc. A date and place is set for the recruitment (see also example of public notice at end of the Module).
- All persons who would like to have a job during the project place their name on a piece of paper. All names are collected in a container. A neutral person selects the names out of the container one at a time and the names are written down in the order in which they are drawn. Persons are then offered a job in the order in which their names were selected.
- Adaptations can be made:
- Limitations of those who can participate can be based on: - where they live (close to the project), -previous unemployment, - households with single adult heads, etc. Household names are used instead of individuals.

Payment:

- Time Based; Worker is paid on the basis of how much time he or she is present at the place of work.
- Productivity Based; Worker is paid on the basis of how much he or she produces.

Daily Paid:

- The worker is paid a fixed sum each day in return for working a fixed number of hours per day. The number of hours, number of breaks, start and finish time are established.
- Production is assured by supervision and by disciplinary measures for workers who do not produce.

- One day's worth; no assurance of quantity
- Easy book-keeping, simple to organize
- High amount of supervision is required to maintain a reasonable output. The rate of progress can be extremely variable.

Piece Work:

- The worker is paid on the basis of small quantities of output. There is no reference made to the amount of time it takes to accomplish one piece.
- Production is assured as payment is made only upon production.
- Many pieces, usually unlimited
- Pay relates to output and output can be maximized each day.
- Tendency to self-exploitation as no limit is placed on the amount of work a worker can do. Difficult to control by government administration.

Task Work:

- The worker is paid a fixed wage in return for a fixed quantity of work, or task. The size of the task is usually set to be accomplished in eight hours. The size of a task may be smaller and more tasks may be given in a single day; the smaller the task the more like piece work. The size of the task may be large, set to be accomplished over several workdays and perhaps with several other workers.
- Production is assured as payment is made only upon production.
- Usually one task. Where the task is small, usually 2 or 3 per day; where the task is larger, a fraction of one task a day. A rule may limit the number of tasks, which may be done in one workday.
- Where task is set properly, allows typical worker to finish task and go home.
- Requires close supervision and monitoring in the daily laying out of work and overall setting of task size. When deviations are made from the usual model, particularly as regard the amount of work (number of tasks and portions of tasks), which can be done every day, possibility for exploitation.

Payment in kind:

- Most workers like to be paid in cash money. However, for a number of reasons:
- They may be offered things of value other than cash money or
- Actually prefer to receive things other than cash money for their work; food, for example, particularly where it is scarce.
- Inconsistent quality of food
- High real delivery costs
- Distortion of food production markets, and
- Difficult logistics

Correct and timely wage payments keep labour-based infrastructure programmes working. Without them:

- Project progress can be seriously slowed or stopped because of labour problems and strikes
- Project costs go up because of delayed production
- The quality of the final infrastructure can go down because workers and supervisors, loose motivation to produce high quality work
- The social objective of providing gainful employment is weakened or lost, and
- The continued use of labour-based methods is threatened.

P.3 SAFETY AND HEALTH ON SITE

Essential Safety Measures:

- First aid kit to be on site!
- Protective goggles for stone cutting, chiselling, grinding, and welding.
- Gloves for handling chemicals, waste and other hazardous material.
- Face masks when working in dust and smouldering waste.
- Helmets when working on sites where there is a danger of falling objects, e.g. in deep drains, digging pit latrines, work in quarries, etc.
- The Site Supervisor should also know where the nearest hospital / clinic is and where an ambulance or quick transport can be found.
- It is also advisable that the Site Supervisor has first aid knowledge.

Special safety measures are required when **deep trenches** have to be dug, for example for culverts or structures. The space is often restricted and it is not possible to dig trenches with safe slopes. Depending on the material (natural soil slope) and the depth of the trench strutting will be required to avoid collapsing trench sides. The construction of strutting has to be done carefully and required an experienced builder.

Essential Health Measures:

- Sufficient and clean drinking water to be on site.
- Latrines on or near site to be available for the workers.
- No alcoholic drinks or drugs during work.



For traffic control and safety measures refer to Module J.

P.4 HIV and AIDS

What are HIV and AIDS?

HIV stands for “Human Immunodeficiency Virus”. HIV is a virus that causes AIDS (Acquired Immune Deficiency Syndrome). HIV destroys the biological ability of the body to fight off opportunistic infections such as tuberculosis. A person can be infected with the virus for a long time without showing any symptoms of the disease. Nonetheless, during that period before the person develops symptoms, he or she can transmit the infection through sexual contact to other, uninfected persons. An infected woman can also transmit the disease to her infant during pregnancy or delivery or while breastfeeding. HIV can also be spread by transfusion of contaminated blood and by sharing needles used for injections and drug use.

AIDS itself is defined in terms of how much deterioration of the immune system has taken place as seen by the presence of opportunistic infections. Unless persons pass away from something else first, virtually all infected people will eventually die from the disease. Most will be dead within ten years of infection and many will die even sooner.

How severe is the disease?

The impact of the AIDS epidemic is being increasingly felt in many countries across the world. By far the worst affected region, sub-Saharan Africa, is now (2002) home to 29.4 million people living with HIV/AIDS. Approximately 3.5 million new infections occurred there in 2002, while the epidemic claims the lives of an estimated 2.4 million Africans in the past year. Ten million young people (aged 15 to 24) and almost 3 million children under 15 are living with HIV.

In Zambia the death toll is staggering. The HIV/AIDS prevalence rate in the country is about 20%. Through 1999, the cumulative number of AIDS deaths from the beginning of the epidemic may be estimated at about 650,000. There were also about 520,000 orphans by year 1999 as a result of the epidemic.

Many of the workers in the road sector belong to the vulnerable bracket of young men and women living away from home. Because they work during the day, workers do not have the time to participate in HIV/AIDS education programmes organised by the government or NGOs

What can I do as a Contractor to control the spreading of the disease amongst my staff and labourers?

- In Zambia there are many programmes and organisations that deal with HIV/AIDS awareness creation and counselling programmes. **Seek their advice and support.** These programmes and organisations specialise in dealing with issues such as adolescent behaviour, child abuse, bereavement and death, relationships, precautions for handling blood in the workplace, etc.
- **Conduct regular awareness creation meetings** with your workforce. Invite specialised organisations to address them. If possible allow the public to participate. Propose such measures when you prepare your bid and discuss with the client how associated costs could be covered. During the pretender meeting make it a habit to ask the client questions concerning HIV/AIDS awareness activities and how these should be dealt with in the contract. (It is not uncommon these days that special clauses concerning HIV/AIDS campaigns are already part and parcel of the contract).
- **Provide condoms** at the work site if possible. Although an attitude change is needed to come to terms with the disease, proper condom use and constant supply of condoms is an effective way of dealing with AIDS.



Do not hesitate to contact health organisations to assist you in dealing with HIV/AIDS issues.

Do not hesitate to discuss HIV/AIDS with your staff and labour force. It is an issue that concerns all of us!!

ANNEX

NOTICE OF RECRUITMENT OF CASUAL LABOUR FOR ROAD WORKS	
DISTRICT/CONTRACTOR:.....	
ADDRESS:.....	
ROAD NO:.....	ROAD FROM:
TO:.....	
<p>There will be a recruitment drive for casual workers for road construction at the time and place given below. All citizens of Zambia, Men and Women, of 16 years of age and older, may apply for employment. Persons residing close to the following location(s) are encourage to apply:</p> <p>.....</p> <p>.....</p> <p>All persons will be given equal opportunity of employment. Selection of those to be recruited will be made by secret ballot. Please note that all applicants must bring their (valid) NRC.</p>	
PLACE OF RECRUITMENT:	
DATE OF RECRUITMENT:	TIME:
NAME OF RECRUITMENT OFFICER:	
DATE:	SIGNATURE:

CASUAL EMPLOYMENT FORM FOR ROAD WORKS

NAME AND ADDRESS OF CONTRACTOR:
.....
.....

ROAD NO:
.....

ROAD FROM:
.....

EMPLOYMENT FORM NO:
.....

TO:
.....

NAME OF EMPLOYEE MR/MRS:
.....

DAILY WAGE RATE:
.....

K / DAY

N.C.R. NO:
.....

COMMENCEMENT DATE OF EMPLOYMENT:
.....

CONDITIONS OF EMPLOYMENT:

1. This agreement is for employment for a period of one working day. When the employee reports for work and is offered employment on subsequent days, the terms and conditions of this agreement are deemed to be automatically extended each day up to a maximum period of 30 days.
2. Wages will be aggregated and paid over monthly pay periods.
3. Daily wages, including those for work carried out on Saturdays, Sundays or Public Holidays will be paid on the daily rate quoted above.
4. Employees completing 10 to 17 days in any monthly pay period will be paid a bonus equivalent to one daily wage quoted above. Employees completing 18 or more days in any monthly pay period will be paid a bonus equivalent to two daily wages quoted above.
5. Payment of allowances, housing, leave or any other types of entitlements are included in the above quoted daily rate.
6. The replacement cost for any tools or equipment lost by the Employee will be deducted from payments due to the Employee.
7. This agreement may be renewed for additional periods not exceeding 30 days by mutual agreement and signature of the contract parties hereto below.

I have read/had read to me the above terms and conditions, and fully understand them.
I hereby accept the casual employment on the terms and conditions on this form.

Name of Employee:	Date:	Signature of Employee
Name of Employer (or Representative):	Date:	Signature of Employer (or Representative):
Witnessed by:	Date:	Signature of Witness:

Original to Employee,
Duplicate to Employer

RENEWAL OF AGREEMENT		
<p><u>1st Renewal</u> I hereby accept the renewal of casual employment as per the terms and conditions on this form for the period from:..... to :.....</p>		
Name of Employee:	Date:	Signature of Employee
Name of Employer (or Representative):	Date:	Signature of Employer (or Representative):
Witnessed by:	Date:	Signature of Witness:
<p><u>2nd Renewal</u> I hereby accept the renewal of casual employment as per the terms and conditions on this form for the period from:..... to :.....</p>		
Name of Employee:	Date:	Signature of Employee
Name of Employer (or Representative):	Date:	Signature of Employer (or Representative):
Witnessed by:	Date:	Signature of Witness:
<p><u>3rd Renewal</u> I hereby accept the renewal of casual employment as per the terms and conditions on this form for the period from:..... to :.....</p>		
Name of Employee:	Date:	Signature of Employee
Name of Employer (or Representative):	Date:	Signature of Employer (or Representative):
Witnessed by:	Date:	Signature of Witness:

R **CE MATERIAL:**

Reference Material

The following titles have been consulted to prepare this Hand Book. Should the reader be interested in more details then the titles with and asterisks are recommended for reading.

Module A:

- Road Maintenance Manual, MOPWH Department of Staff Training, Kenya, Manual Part 1 (by Christian Deschenaux)
- Taschenbuch für Bauführer und Poliere, SBKV, Switzerland (by Franz Büchel)
- Supervisor's Site Reference Handbook, Site Supervisor Course for Labour-Based and Community-Managed Upgrading of Urban Low-Income Settlements, ILO, (by A. Beusch and M. Winsvold).

Module B:

- *ROMAR Handbook, IT Publications for ILO (by Claes Andersson, Andreas Beusch and Derek Miles)
- Roads - Labour-Based Methods, Field Training Unit, Roads Department, Botswana (by Ørnulf Strom)

Module C:

- *ROMAR Handbook, IT Publications for ILO (by Claes Andersson, A. Beusch and Derek Miles)

Module D:

- *ROMAR Handbook, IT Publications for ILO (by Claes Andersson, Andreas Beusch and Derek Miles)
- Technical Manual, Vol. I, Minor Roads Programme MOPW&H Kenya, (by Intech Associates)

Module E:

- *Technical Manual for Labour-Based Road Rehabilitation Works, Republic of Zambia, Ministry of Works and Supply (by Roads Department Training School with Norconsult A.S. Nairobi, Kenya, Walter Illi)
- *Culvert Manual, An Introduction to Hydraulics, Design and Construction, Ministry of Works and Supply Zambia (by Carl Eric Hedström)
- Supervisor's Site Reference Handbook, Site Supervisor Course for Labour-Based and Community-Managed Upgrading of Urban Low-Income Settlements, ILO, (by A. Beusch and M. Winsvold).
- *PIARC Road Maintenance Handbook, Volume I (by TRL, Robert Petts)
- ROCAU (Road Construction and Upgrading) Training Manual, Ministry of Works, Lesotho (by Andreas Beusch for ILO ASIST)

Module F:

- Road Maintenance Manual, MOPWH Department of Staff Training, Kenya, Manual Part 3 (by Christian Deschenaux)
- Taschenbuch für Bauführer und Poliere, SBKV, Switzerland (by Franz Büchel)
- Strassenbau, Kantonale Bauschule Aarau, Switzerland
- Geotechnik für die Baupraxis, Baudepartement Aarau, Abt. Tiefbau, (by Dipl. Ing. H. Otto)
- *Highway and Traffic Engineering in Developing Countries, (edited by Bent Thagesen)s

Module G:

- Road Maintenance Manual, MOPWH Department of Staff Training, Kenya, Manual Part 2 (by Christian Deschenaux)
- Technical Manual, Vol. I, Minor Roads Programme MOPW&H Kenya, (by Intech Associates)
- Baustoff Beton, Ein Handbuch für die Baupraxis, (by Dr. sc. techn. Ulrich Trüb)

Module H:

- Road Maintenance Manual, MOPWH Department of Staff Training, Kenya, Manual Part 2 (by Christian Deschenaux)
- Technical Manual, Vol. I, Minor Roads Programme MOPW&H Kenya, (by Intech Associates)
- Taschenbuch für Bauführer und Poliere, SBKV, Switzerland (by Franz Büchel)
- Low Cost Road Construction in Indonesia, Documentation for Intercooperation (by A. Beusch, P. Hartmann, R.C. Petts and P. Winkelmann)

Module I:

- Road Maintenance Manual, MOPWH Department of Staff Training, Kenya, Manual Part 2 (by Christian Deschenaux)
- Technical Manual, Vol. I, Minor Roads Programme MOPW&H Kenya, (by Intech Associates)

Module J:

- Road Maintenance Manual, MOPWH Department of Staff Training, Kenya, Manual Part 2 (by Christian Deschenaux)
- *ROMAR Handbook, IT Publications for ILO (by Claes Andersson, Andreas Beusch and Derek Miles)
- *PIARC Road Maintenance Handbook, Volume IV (by TRL, Robert Petts)

Module K:

- *Routine Road Maintenance Specifications for Gravel and Earth Roads, Ministry of Works and Supply Zambia, Roads Department Training School.
- *Performance Contract, Method Specification for Pothole and Edge Repair on Bitumen Roads Surfaced Roads, Ministry of Works and Supply, Zambia, Roads Department.
- *PIARC Road Maintenance Handbooks, Volumes I to IV (by TRL, Robert Petts)
- *ROMAR Handbook, IT Publications for ILO (by Claes Andersson, Andreas Beusch and Derek Miles)
- Maintenance Manual, Vol. II, Minor Roads Programme MOPW&H Kenya, (by Intech Associates)
- Management and Supervision of Labour-Based Road Construction and Maintenance, Ministry of Works Transport and Communications, Republic of Botswana, Roads Training Centre, (by Andreas Beusch and Rolf Johansen).
- *Manual for the Labour-Based Construction of Bituminous Surfacing on Low-Volume Roads, Transport Research Laboratory, UK.

Module L:

- Road Maintenance Manual, MOPWH Department of Staff Training, Kenya, Manual Part 3 (by Christian Deschenaux)
- *ROMAR Handbook, IT Publications for ILO (by Claes Andersson, Andreas Beusch and Derek Miles)

REFERENCE MATERIAL

- International Courses for Engineers and Managers of Labour-based Road Construction and Maintenance Programmes, Course Notes Volume I, ILO Publication (by Andreas Beusch and Jan de Veen)

Module M:

- *Technical Manual for Labour-Based Road Rehabilitation Works, Republic of Zambia, Ministry of Works and Supply (by Roads Department Training School with Norconsult A.S. Nairobi, Kenya, Walter Illi)
- Technical Manual, Vol. I, Minor Roads Programme MOPW&H Kenya, (by Intech Associates)
- *Routine Road Maintenance Specifications for Gravel and Earth Roads, Ministry of Works and Supply Zambia, Roads Department Training School.
- *Performance Contract, Method Specification for Pothole and Edge Repair on Bitumen Roads Surfaced Roads, Ministry of Works and Supply, Zambia, Roads Department.

Module N:

- International Courses for Engineers and Managers of Labour-based Road Construction and Maintenance Programmes, Course Notes Volumes I and II, ILO Publication (by Andreas Beusch and Jan de Veen)
- *ROMAR Handbook, IT Publications for ILO (by Claes Andersson, Andreas Beusch and Derek Miles)

Module O:

- *Contracting Manual for Labour-Based Road Rehabilitation Works, Republic of Zambia, Ministry of Works and Supply (by Roads Department Training School with Norconsult A.S. Nairobi, Kenya, Walter Illi)
- *ROMAR Handbook, IT Publications for ILO (by Claes Andersson, Andreas Beusch and Derek Miles)
- Work Management for Contractors, Environmental Friendly Road Construction in Bhutan, Royal Government of Bhutan, Department of Roads, (by A. Beusch, Intech Beusch & Co.).
- Supervisor's Site Reference Handbook, Site Supervisor Course for Labour-Based and Community-Managed Upgrading of Urban Low-Income Settlements, ILO ASIST, (by A. Beusch and M. Winsvold).

Module P:

- *Technical Manual for Labour-Based Road Rehabilitation Works, Republic of Zambia, Ministry of Works and Supply (by Roads Department Training School with Norconsult A.S. Nairobi, Kenya, Walter Illi)
- Supervisor's Site Reference Handbook, Site Supervisor Course for Labour-Based and Community-Managed Upgrading of Urban Low-Income Settlements, ILO ASIST, (by Andreas Beusch and M. Winsvold).
- *Prelude to Decision Making: Labour Standards in Zambia's Labour-Based Roads Sector, ILO SAMAT.
- *The Labour Laws (Zambia), by A.S. Makanta, Principal Labour Officer, Labour Department, Zambia.
- *HIV/AIDS in Zambia, Background, Projections, Impacts, Interventions; Ministry of Health, Central Board of Health.
- *Employment – Intensive Infrastructure Programmes: Labour Policies and Practices, ILO, (by D. Tajgman and J. de Veen)

INDEX:

Index

A ctivities (emergency maintenance)	K-6	Catch Water Drains (activity sheet)	E-36
Activities (periodic maintenance)	K-6	Catchpit	E-3
Activities (road construction)	E-14	Cationic (emulsion)	K-24
Activities (routine maintenance)	K-5	Causeway	E-2
Activity Sheets (road construction)	E-20	Cement	G-1
Activity Sheets (gravelling)	E-53	Centre line	E-2
Activity Sheets (routine maintenance)	K-11	Chippings	K-4
Adjudication	O-12	Claims	O-11
Aggregate Brooming	K-2	Clay	B-1
Aggregate Silo	K-3	Client	O-2
Aggregates (for concrete)	G-1	Coarse grain (soil)	B-1, B-2
AIDS / HIV	P-6	Coffer Dam	E-2
Angles (setting out)	D-4	Cohesive (soil)	B-1
Anionic (emulsion)	K-24	Cold Asphalt Premix	K-27
Apron	E-3	Cold Asphalt Premix Preparation	K-27
Arbitration	O-13	Compaction	B-1, E-13, F-1
Arch Culvert	E-47	Compaction of Gravel Layer	E-60
Area	A-1	Compaction Plant / Equipment	F-2
Asphalt	K-4	Completion Works	O-13
Asphaltic Concrete	K-4	Concrete Batching	G-3
Award of Contract	O-4	Concrete Curing	G-8
		Concrete Joints	G-7
		Concrete Mixing	G-3
		Concrete Placing	G-5
		Concrete Technology / Works	G-1
B acksloping (activity sheet)	E-32	Concrete Transporting	G-5
Base	E-2	Condition (road condition)	E-11
Basin	E-3	Construction Joints (concrete)	G-6
Bearing Capacity	B-1	Contract Documents	O-2
Berm	E-3	Contract Management Activities	O-1
Bitumen Emulsion	K-4 , K-24	Contract Management Stages	O-1
Bitumen Heater-Distributor	K-3	Contract Management	O-10
Bituminous Binder	K-4	Contract Manager	O-2
Bituminous Slurry	K-4	Contract Supervision	O-8
Black Cotton (soil)	B-6	Contracting Parties	O-2
Bleeding	K-1	Contractor	O-2
Blinding	E-1	Cracking	K-1
Block Cracking	K-1	Crazing (alligator cracks)	K-1
Bond (for stone masonry)	H-3	Cross-Section (standard sections)	E-5
Boning Rod	D-2	Crown	E-2
Boulder Removal (activity sheet)	E-24	Culvert Bedding, Haunching	E-44
Box Culvert	E-47	Culvert Casting	I-1
Brick and Block Masonry	H-5	Culvert Casting Facilities	I-1
Bridge	E-1	Culvert Cleaning (maintenance activity sheet)	K-12
Bush Clearing (activity sheet)	E-21	Culvert Curing	I-2
		Culvert Loading, Transport	I-2
		Culvert Moulds	I-1
C amber Formation (activity sheet)	E-34	Culvert Production	I-1
Camber	E-1	Culvert Repair (mtce. activity sheet)	K-21
Camberboard	D-2	Culvert Setting Out	E-39
Camp (site camp)	C-1 , E-16	Culvert	E-2, E-38
Camp Location	E-11		
Capacity	A-3		
Carriageway	E-1	D aily Paid	E-15
Carriageway Reshaping (mtce. activity sheet)	K-20	Daily Paid	P-4
Catch Water Drain	E-3	Daily Plan and Report	N-2

INDEX

Daily Service (for vehicles)	L-6	Gravel Hauling	E-57
Daily Service (for vehicles)	L-7	Gravel Loading	E-56
Deck (bridge)	E-2	Gravel Off-Loading and Spreading	E-58
Demobilisation	O-13	Gravel Quantities	E-52
Density	A-4	Gravelling	E-51
Depression (pavement)	K-1	Gravelling Equipment and Tools	E-52
Dispute	O-12	Gritter	K-3
Ditch (drain)	E-3	Grubbing (activity sheet)	E-22
Ditch Template	D-2	Grubbing Edges (mtce. activity sheet)	K-23
Ditch/Slope Template	D-2		
Ditching (activity sheet)	E-31	H and Tools	C-2
Drag	K-3	Handing Over (the works)	O-14
Drain Erosion Repair (mtce. activity sheet)	K-16	Hauling	E-13
Drainage	E-3	Hauling Gravel	E-57
Drift	E-2	Headwall	E-3
Drift	E-46	Health Measures	P-6
Drive Cylinder	F-4	HIV / AIDS	P-6
Dry-Stone Masonry	H-4	Hoist	K-3
Dynamic Cone Penetrometer	F-5	Hopper	K-4
		Horizontal Curves (setting out)	D-5
E arth Road Works	E-19		
Edge Cracking	K-1	I dentification of soils (simple field test)	B-2
Embankment	E-2	Incentive Schemes	E-15
Emergency Maintenance	K-2, K-5	Inspection (maintenance activity sheet)	K-11
Equality (labour regulation)	P-2	Instruction to Tenderers	O-4
Equipment Control	L-3	Interim Payment Certificate	O-10
Equipment Maintenance	L-1	Invert	E-4
Erosion Repair (maintenance activity sheet)	K-13	Labour Acts	P-1
Excavation to Level (activity sheet)	E-30	Labour Laws and Regulations	P-1
		Labour Payment	P-4
F air Working Conditions	P-4	Labour Recruitment and Remuneration	P-3
Field Density Tests	F-4		
Final Inspection	O-14	L aterite (soil)	B-6
Fine grain (soil)	B-1, B-2	Layby	E-2
Flemish Bond (masonry)	H-6	Lean Concrete	G-2
Fog Seal	K-2	Length	A-1
Ford	E-2	Lengthperson	K-2, K-8
Formation	E-2	Level (setting out)	D-7
Formwork Removal	G-8	Line Level	D-3
Freedom from Forced Labour	P-2	Liquidated Damage	O-12
Freedom of Association	P-2	Logbook (for equipment/vehicles)	L-3
Fretting (pavement)	K-1	Lottery System (labour recruitment)	P-4
G abion	K-4	M aintenance (of roads)	K-1
Gabion Works	E-49	Maintenance Management	K-7
Ganging Rod	D-1	Maintenance of Works (for contracts)	O-16
Gangsystem (for maintenance)	K-8	Maintenance Period (of contracts)	O-15
Glazing (pavement)	K-2	Margins	E-2
Grader	K-3	Masonry	H-1
Gradient (setting out)	D-7	Masonry Tools	H-6
Grass Cutting (activity sheet)	E-22	Masonry, quantities	H-2
Gravel	B-1	Mass Concrete	G-2
Gravel Compaction	E-60	Measurement of Works	O-10
Gravel Excavation (activity sheet)	E-55	Measuring Aids	D-1

INDEX

Minimum Age	P-2	Programming Work	N-1
Minimum Wage	P-2	Protection of Wages	P-2
Mitre Drain	E-4		
Mitre Drain Cleaning (mtce. activity sheet)	K-14	Quality Control	O-8
Mitre Drain Construction (activity sheet)	E-35	Quality Control (for concrete work)	G-9
Mobilisation	O-5	Quality Control (for earth road construction)	E-38
Mortar	H-1	Quality Control (for gravelling work)	E-61
Mortar, mixing proportions	H-2	Quality Control (for masonry work)	H-7
Moulding	B-1	Quarry	E-13
Musterrroll	N-2	Quarry Access	E-11
		Quarry Preparation (activity sheet)	E-54
Non-cohesive (soil)	B-1, B-2	Quarter Method (setting out curves)	D-5
Notice of Tender	O-4		
Nuclear Density Gauge	F-5	Rectification of Defects	O-16
Obligations of the Client	O-5	Red Coffee (soil)	B-6
Obligations of the Contractor	O-5	Reports (for site work)	N-2
Obstruction Removal (mtce. activity sheet)	K-11	Reshaping (activity sheet)	E-53
		Retention Money	O-10
Offset Method (setting out curves)	D-5	Road Paver	K-4
Optimum Moisture Content (MOC)	B-1	Roadway	E-2
Organic (soil)	B-1, B-2	Rock Excavation (activity sheet)	E-25
Organisation (site)	E-16	Routine Maintenance	K-3, K-5
Outfall	E-4	Routine Maintenance Activities, paved	K-24
		Routine Maintenance Activities, unpaved	K-10
Parapet	E-2	Rubber Balloon	F-4
Pass	K-2	Rutting	K-2
Patching	K-2		
Paved Road	E-1	Safety	J-1, J-3
Pavement	E-2	Safety (for equipment handling)	L-8
Paver Screed Plate	K-4	Safety and Health on Site	P-6
Peg	D-1	Safety and Health	P-3
Periodic Maintenance	K-2, K-5	Safety Measures	P-6
Permeability	B-1	Sand Replacement	F-4
Piece Work	E-15, P-5	Sand	B-1
Planning and Reporting (for routine maintenance)	K-9	Sanding	K-3
Planning Site Work	N-3	Sandy Soil	B-6
Plans (for site work)	N-2	Scarifying	K-3
Plant Maintenance	L-1, L-5	Scour	K-2
Plasticity	B-1	Scour Check	E-4
Plumb Bob	D-3	Scour Checks (activity sheet)	E-37
Poorly graded (soil)	B-1	Scour Checks Repair (mtce. activity sheet)	K-17
Post Construction Evaluation	O-17	Sealing Cracks (mtce. activity sheet)	K-31
Potholes	K-2, K-19	Setting Out (activity sheet)	E-20
Pothole Patching (mtce. activity sheet)	K-30	Setting Out Vertical Alignment (activity sheet)	E-26
Pothole Repair	K-19	Shoulder	E-2
Prequalification	O-4	Shoulder, Slopes Repair (mtce. activity sheet)	K-18
Pressure	A-5	Side Drain Cleaning (mtce. activity sheet)	K-15
Productivity Rates	E-16, M-1	Signs (for traffic control)	J-1
Productivity and Cost Control	O-17	Silt	B-1
Productivity Rates for Earthworks	M-1	Site Agent	O-2
Productivity Rates for Gravelling Works	M-3	Site Inspection	O-8
Productivity Rates for Hauling	M-5	Site Inspection (for construction works)	N-4
Productivity Rates for Routine Maintenance	M-6	Site Inspection (for maintenance works)	K-7
Profile Board	D-2	Site Inspection	E-11

INDEX

Site Instructions	O-9	Variation Orders	O-10
Site Meetings	O-9	Vegetation Control (mtce. activity sheet)	K-22
Site Records	O-9	Vended Drift / Ford	E-2
Slope	A-4, E-3	Vented Drift	E-47
Sloping (activity sheet)	E-33	Volume	A-2
Slurry Seal (mtce. activity sheet)	K-32	Water (for concrete, mortar)	G-2
Slurry Seal	K-3	Water-Cement Ration (for concrete)	G-4
Sod	K-5	Weekly Plan and Report	N-2
Soffit	E-4	Weekly Service (for plants)	L-5
Soil Characteristics	B-6	Weekly Service (for vehicles)	L-7
Spare Parts (for equipment)	L-2	Weephole	E-4
Spirit Level	D-3	Weight	A-3
Spray Lance	K-4	Wind Row	K-3
Squeegee	K-4	Wingwall	E-3
Stone Masonry	H-3	Work Approval	O-9
Stone Masonry, Foundations	H-3	Work Planning	E-13
Stone Masonry, Walls	H-3	Workshop Equipment and Tools	L-2
Stones (for masonry)	H-1	Workshop, Mechanical on Site	L-1
Store Forms	N-2		
Straight Edge	D-3		
Straight Line (setting out)	D-4		
Streaking	K-2		
Stretcher Bond (masonry)	H-6		
String Method (setting out curves)	D-5		
Strip Map	N-6		
Stripping (activity sheet)	E-22		
Structural Concrete	G-2		
Structure Construction	E-48		
Sub-Base	E-2		
Subgrade	E-3		
Surface Aggregate Loss	K-2		
Surface Dressing	K-3		
Surface Edge Patching (mtce. activity sheet)	K-28		
Surface Treatment	E-3		
Surfacing	E-3		
T angent Method (setting out curves)	D-5		
Tape Measure	D-1		
Tar Binder	K-5		
Task Rates	E-15		
Task Work	P-5		
Template	D-2		
Tender Evaluation	O-4		
Tender Opening	O-4		
Tender Period	O-4		
Tender Procedures	O-3		
Tools (for routine maintenance)	K-8		
Traffic Control	J-1		
Traffic Lane	E-3		
Tree and Stump Removal (activity sheet)	E-23		
U niformly graded (soil)	B-1		
Unit Conversion	A-8		
Unpaved Road	E-1		